



This is a digital copy of a book that was preserved for generations on library shelves before it was carefully scanned by Google as part of a project to make the world's books discoverable online.

It has survived long enough for the copyright to expire and the book to enter the public domain. A public domain book is one that was never subject to copyright or whose legal copyright term has expired. Whether a book is in the public domain may vary country to country. Public domain books are our gateways to the past, representing a wealth of history, culture and knowledge that's often difficult to discover.

Marks, notations and other marginalia present in the original volume will appear in this file - a reminder of this book's long journey from the publisher to a library and finally to you.

Usage guidelines

Google is proud to partner with libraries to digitize public domain materials and make them widely accessible. Public domain books belong to the public and we are merely their custodians. Nevertheless, this work is expensive, so in order to keep providing this resource, we have taken steps to prevent abuse by commercial parties, including placing technical restrictions on automated querying.

We also ask that you:

- + *Make non-commercial use of the files* We designed Google Book Search for use by individuals, and we request that you use these files for personal, non-commercial purposes.
- + *Refrain from automated querying* Do not send automated queries of any sort to Google's system: If you are conducting research on machine translation, optical character recognition or other areas where access to a large amount of text is helpful, please contact us. We encourage the use of public domain materials for these purposes and may be able to help.
- + *Maintain attribution* The Google "watermark" you see on each file is essential for informing people about this project and helping them find additional materials through Google Book Search. Please do not remove it.
- + *Keep it legal* Whatever your use, remember that you are responsible for ensuring that what you are doing is legal. Do not assume that just because we believe a book is in the public domain for users in the United States, that the work is also in the public domain for users in other countries. Whether a book is still in copyright varies from country to country, and we can't offer guidance on whether any specific use of any specific book is allowed. Please do not assume that a book's appearance in Google Book Search means it can be used in any manner anywhere in the world. Copyright infringement liability can be quite severe.

About Google Book Search

Google's mission is to organize the world's information and to make it universally accessible and useful. Google Book Search helps readers discover the world's books while helping authors and publishers reach new audiences. You can search through the full text of this book on the web at <http://books.google.com/>

B 543619 DUPL

LINOTYPE

SPECIMEN FACES

ALSO

BORDERS, DASHES & RULES

1907

MERGENTHALER LINOTYPE CO.

NEW-YORK · CHICAGO · SAN FRANCISCO · NEW-ORLEANS

PARIS

MERGENTHALER CO. LTD, TORONTO

627

CAUTION

Do not mutilate or destroy this book. All matrices can be ordered by number or name. Only one copy will be furnished free of charge.

Z
253
.M56

THIS ENTIRE BOOK WAS COMPOSED
ON THE LINOTYPE AND PRINTED
DIRECT FROM THE SLUGS :: :: ::

CAUTION

SOME OF OUR LARGER FACES WILL
NOT RUN IN THE MODEL 1 MACHINE.
SEE LAST LINE OF FOOT NOTE ON
SPECIMEN PAGES :: :: :: :: ::

INDEX TO SPECIMENS

ONE-LETTER BOOK AND NEWS FACES

	Page		Page
5-Point No. 18.....	48	8-Point German No. 3.....	96
5½-Point No. 1.....	10	8-Point Hebrew	103
5½-Point No. 2.....	22	8-Point Greek	106
5½-Point No. 3.....	30	9-Point No. 13 (Old Alignment)...	42
6-Point No. 1.....	12	9-Point No. 13 (New Alignment)...	44
6-Point No. 2.....	24	9-Point Old Style No. 1.....	64
6-Point No. 3.....	32	9-Point Ronaldson	74
6-Point German No. 1.....	36	9-Point German No. 2.....	90
6-Point German No. 3.....	94	9-Point Hebrew	104
6-Point No. 12.....	40	10-Point No. 1.....	18
6-Point Old Style No. 1.....	60	10-Point No. 12.....	46
6-Point Ronaldson	70	10-Point Cheltenham	56
6-Point Hebrew	102	10-Point Old Style No. 1.....	66
7-Point No. 1.....	14	10-Point Ronaldson	76
7-Point No. 2.....	26	10-Point Elsevir No. 1.....	82
7-Point No. 3.....	34	10-Point German No. 2.....	92
7-Point No. 21.....	52	10-Point German No. 3.....	98
8-Point No. 1.....	16	10-Point Greek	107
8-Point No. 2.....	28	11-Point No. 1.....	20
8-Point No. 3.....	36	11-Point No. 9.....	38
8-Point No. 4.....	38	11-Point Old Style No. 1.....	68
8-Point No. 19.....	50	11-Point Ronaldson	78
8-Point Cheltenham	54	11-Point German No. 3.....	100
8-Point Old Style No. 1.....	62	11-Point Hebrew	106
8-Point Ronaldson	72	12-Point Elsevir No. 1.....	84
8-Point Elsevir	80	12-Point Cheltenham	58
8-Point German No. 1.....	88		

TWO-LETTER BOOK AND NEWS FACES

5-Point No. 10 with Gothic No. 4.....	164	7-Point Caslon	364
5½-Point No. 1 with Clarendon No. 1.....	110	8-Point No. 1	120
5½-Point No. 1.....	112	8-Point No. 3 with Bold Face No. 1	184
5½-Point No. 2 with Bold Face No. 2.....	128	8-Point No. 2 with Gothic No. 3.....	140
6-Point No. 1.....	116	8-Point No. 2 with Condensed Title No. 3	142
6-Point No. 1 with Bold Face No. 2	114	8-Point No. 2 with 10-Point Clar- endon No. 1	144
6-Point No. 2 with Bold Face No. 1.....	120	8-Point No. 2	150
6-Point No. 2 with Gothic No. 3.....	126	8-Point No. 4.....	154
6-Point No. 2 with Antique No. 2.....	146	8-Point No. 19.....	172
6-Point No. 2.....	148	8-Point No. 19 with Title No. 1.....	174
6-Point No. 3.....	152	8-Point Century Expanded	176
6-Point No. 12.....	166	8-Point Old Style No. 1.....	182
6-Point Old Style No. 1.....	184	8-Point Ronaldson	202
6-Point Ronaldson	198	8-Point Old Style No. 1 with An- tique No. 1.....	214
6-Point Old Style No. 1 with An- tique No. 1.....	212	8-Point Ronaldson with Antique No. 1.....	224
6-Point Ronaldson with Antique No. 1	222	8-Point Cambridge	232
6-Point De Vinne Series.....	264	8-Point Scotch	246
6-Point De Vinne Series with Antique No. 1.....	276	8-Point Caslon	256
6-Point De Vinne Series with An- tique No. 3.....	278	8-Point De Vinne Series.....	266
6-Point Classic	298	8-Point De Vinne Series with An- tique No. 3.....	280
6-Point No. 3 with Bold Face No. 3 German.....	312	8-Point Cheltenham	290
7-Point No. 1.....	118	8-Point Classic	300
7-Point No. 2 with Bold Face No. 1	132	8-Point No. 3 with Bold Face No. 3 German.....	314
7-Point No. 2 with Gothic No. 3.....	138	9-Point No. 12.....	168
7-Point Old Style No. 1.....	186	9-Point Old Style No. 1.....	190
7-Point Ronaldson	200	9-Point Ronaldson	204
		9-Point De Vinne Series.....	268
		9-Point De Vinne Series with An- tique No. 3.....	282

See Cal. used 2-27-30 E. L. N.

y

TWO-LETTER BOOK AND NEWS FACES—(Continued)

	Page		Page
9-Point No. 3 with Bold Face No. 2 German.....	316	11-Point Ronaldson with Antique No. 1.....	223
10-Point No. 1.....	122	11-Point Cambridge.....	226
10-Point No. 5.....	156	11-Point Scotch.....	260
10-Point No. 6.....	158	11-Point Caslon.....	260
10-Point No. 9.....	160	11-Point De Vinne Series.....	273
10-Point No. 13.....	170	11-Point De Vinne Series with Antique No. 3.....	286
10-Point Century Expanded.....	178	11-Point No. 3 with Bold Face No. 2 German.....	320
10-Point Old Style No. 1.....	192	12-Point No. 1.....	126
10-Point Ronaldson.....	206	12-Point Century Expanded.....	180
10-Point Old Style No. 1 with Antique No. 1.....	216	12-Point Century Expanded with Bold Face No. 1.....	183
10-Point Ronaldson with Antique No. 1.....	226	12-Point-Old Style No. 1.....	196
10-Point Cambridge.....	234	12-Point Ronaldson.....	210
10-Point French Old Style.....	238	12-Point Old Style No. 1 with Antique No. 1.....	220
10-Point Original Old Style.....	240	12-Point Ronaldson with Antique No. 1.....	230
10-Point Scotch.....	248	12-Point Original Old Style.....	242
10-Point Caslon.....	258	12-Point Scotch.....	253
10-Point De Vinne Series.....	270	12-Point Caslon.....	263
10-Point De Vinne Series with Antique No. 3.....	284	12-Point De Vinne Series.....	274
10-Point Cheltenham.....	292	12-Point De Vinne Series with Antique No. 3.....	288
10-Point Classic.....	302	12-Point Cheltenham.....	294
10-Point No. 3 with Bold Face No. 2 German.....	318	12-Point Classic.....	304
10-Point Russian Old Style with Antique No. 1.....	322	14-Point Original Old Style.....	244
10-Point Servian Old Style with Antique No. 1.....	323	14-Point Cheltenham.....	296
11-Point No. 1.....	124	14-Point No. 36.....	306
11-Point No. 9.....	162	14-Point Congressional Roman, Plain and Cancelled.....	308
11-Point Old Style No. 1.....	194	14-Point Congressional Italic, Plain and Cancelled.....	310
11-Point Ronaldson.....	208		
11-Point Old Style No. 1 with Antique No. 1.....	218		

ONE-LETTER JOB FACES

5½-Point Bold Face No. 1.....	460	8-Point Cheltenham Bold Face... 450	
6-Point Clarendon No. 1.....	326	8-Point Celtic No. 1.....	456
6-Point Title No. 2.....	342	8-Point Bold Face No. 1.....	463
6-Point Jenson.....	360	8-Point Bold Face No. 2 German. 480	
6-Point Aldine.....	368	9-Point Bold Face No. 1 German. 476	
6-Point Gothic Italic No. 4.....	402	10-Point Clarendon No. 1.....	330
6-Point Royal Gothic.....	414	10-Point Ionic No. 1.....	336
6-Point Bold Face No. 2 German. 478		10-Point Title No. 1.....	340
7-Point Title No. 2.....	344	10-Point Title No. 2.....	348
7-Point Gothic No. 2.....	386	10-Point De Vinne Condensed.....	356
7-Point Gothic No. 4.....	400	10-Point Jenson.....	364
7-Point Antique No. 1.....	424	10-Point Aldine No. 1.....	372
7-Point Bold Face Italic No. 1... 468		10-Point Condensed Title No. 1... 374	
7-Point Doric No. 1.....	470	10-Point Condensed Title No. 2... 378	
8-Point Clarendon No. 1.....	328	10-Point Gothic Condensed No. 2.. 390	
8-Point Ionic No. 1.....	334	10-Point Gothic No. 3.....	398
8-Point Title No. 1.....	338	10-Point Elsevir Gothic.....	410
8-Point Title No. 2.....	346	10-Point Uniline.....	442
8-Point De Vinne Condensed.....	354	10-Point Law Italic.....	434
8-Point Jenson.....	362	10-Point Latin Antique.....	432
8-Point Aldine.....	370	10-Point Antique No. 1.....	428
8-Point Gothic Condensed No. 2.. 388		10-Point Berlin Antique.....	420
8-Point Gothic No. 3.....	396	10-Point Condensed Antique.....	416
8-Point Gothic Italic No. 4.....	404	10-Point Cheltenham Bold Face... 462	
8-Point Elsevir Gothic.....	408	10-Point Bold Face No. 1.....	464
8-Point Admiral.....	412	10-Point Doric No. 1.....	472
8-Point Royal Gothic.....	415	10-Point Bold Face No. 2 German. 482	
8-Point Antique No. 1.....	426	11-Point Gothic No. 1.....	382
8-Point Latin Antique.....	430	11-Point Doric No. 2.....	474
8-Point Uniline.....	440	11-Point Bold Face No. 2 German. 484	

ERRATA

On page 5, under Rogers Tabular Matrices.

For 6-Point No. 6, page 532, read:
6-Point Gothic No. 6.

For 8-Point German No. 1, page 542, read:
8-Point German No. 1 Figures and 8-Point No. 1
Roman Letters.

For 10-Point Antique No. 1, page 545, read:
10-Point No. 1.

Additional:

7-Point Old Style No. 1, page 548.
12-Point No. 1, page 549.

On page 605, under Rogers Tabular Matrices.

For 8-Point German No. 1, page 542, read:
8-Point German No. 1 Figures and 8-Point No. 1
Roman Letters.

Additional:

10-Point No. 1, page 545.

ONE-LETTER JOB FACES—(Continued)

	Page		Page
12-Point Clarendon No. 1.....	333	12-Point Uniline	444
12-Point Title No. 2.....	350	12-Point Remington Typewriter...	439
12-Point De Vinne Outline.....	353	12-Point Stenograf Typewriter....	438
12-Point De Vinne Condensed.....	353	12-Point Law Italic.....	436
12-Point Jenson	366	12-Point Berlin Antique.....	422
12-Point Condensed Title No. 1....	376	12-Point Condensed Antique.....	418
12-Point Condensed Title No. 2....	380	12-Point Cheltenham Bold Face....	464
12-Point Gothic No. 1.....	384	12-Point Caslon Text.....	458
12-Point Gothic Condensed No. 2..	392	12-Point Bold Face No. 1.....	466
12-Point Gothic No. 5.....	406	14-Point Baskerville Condensed....	448
12-Point Baskerville Condensed....	446	14-Point Gothic Condensed No. 2... 394	

TWO-LETTER JOB FACES

5½-Point Bold Face No. 1 with 10-Point Clarendon No. 1... 498	8-Point Title No. 2 with Title Italic	494
5½-Point Bold Face No. 1 with 8-Point Ionic..... 492	10-Point Uniline with Title No. 1..	508
5½-Point Bold Face No. 1 with Bold Face Italic..... 488	10-Point Bold Face Italic No. 2 with 10-Point Clarendon No. 1.....	504
7-Point Bold Face No. 1 with Bold Face Italic..... 490	10-Point Title No. 2 with Title Italic	496
8-Point Uniline with Title No. 1..	11-Point Antique No. 3 with De Vinne Italic.....	514
8-Point Gothic No. 3 with 10- Point Clarendon..... 502	12-Point Gothic No. 5 with Gothic No. 1.....	512
8-Point Ionic with 10-Point Clar- endon	10-Point Antique No. 3 with 12- Point Gothic No. 1.....	510

TWO-LINE AND SECTIONAL CHARACTERS

10-Point Two-Line	519	11-Point Two-Line Sectional, Two- Letter	526
11-Point Two-Line	519	12-Point Two-Line Sectional, Two- Letter	526
12-Point Two-Line	520	12-Point Gothic No. 4 Sectional, Two-Letter	523
20-Point Gothic No. 1, Two-Line..	520	16-Point Gothic No. 1 Sectional, Two-Letter	526
12-Point Gothic No. 4 Sectional, One-Letter	522	24-Point Gothic No. 1 Sectional, Two-Letter	526
16-Point Gothic No. 1 Sectional, One-Letter	522		
24-Point Gothic No. 1 Sectional, One-Letter	523		

ROGERS TABULAR MATRICES

5½-Point Gothic No. 3.....	529	8-Point Gothic No. 6.....	539
5½-Point Bold Face No. 1.....	530	8-Point Ionic No. 1.....	540
6-Point No. 1.....	531	8-Point Ionic No. 4.....	541
6-Point No. 6.....	532	8-Point German No. 1.....	542
6-Point No. 12.....	533	10-Point No. 6.....	543
6-Point German No. 1.....	534	10-Point No. 12.....	544
7-Point Old Style No. 1.....	543	10-Point Antique No. 1.....	545
8-Point No. 1.....	535	10-Point Antique No. 3.....	546
8-Point No. 4.....	536	10-Point Old Style No. 1.....	547
8-Point No. 19.....	537	12-Point No. 1.....	549
8-Point Old Style No. 1.....	538		

MISCELLANEOUS

Miscellaneous Part Fonts, Etc... 553	Border Matrices and Matrix Slides	565-594
Vertical Slug Table Matrices.. 550, 551	Type resembling Linotype faces	596-602
Accents in common use..... 566		

FOR CLASSIFIED INDEX SEE PAGE 603

GENERAL INFORMATION

Directions for Ordering Supplies

PUBLISHERS are earnestly requested to carefully consider their supply orders before placing them. We cannot exchange or give credit for matrices, molds, or other supplies furnished on order, as the labor and expense of testing, inspecting, and sorting forbid our doing so. Supplies thus furnished are, therefore, useless to us if returned.

Customers are cautioned to carefully observe the instructions given below when ordering supplies. By so doing they will avoid mistakes, and save time and trouble.

When ordering matrices use printed Matrix Order Blanks, which we supply free on request.

State plainly name of font and number of face desired, specifying whether fractions are wanted, and if so whether they are to be on an "em" or "en" or "figure set," and whether they are to be run in keyboard, pi box, or in special channels.

When ordering sets of caps or lower case matrices, state if a to z only are wanted.

If you are using No. 1 faces with No. 2 table characters, or No. 2 faces with No. 1 table characters, or any other combination of faces, please specify this in your order.

When ordering italics, black faces, or special matrices, always specify whether they are to run pi or in the magazine.

When ordering 11-point Gothic head letter matrices, state whether they are to be used on 9-point or 11-point body.

Matrices for sorting up can be furnished, independent of sets, in any quantities.

If you are in doubt as to the number of the face you are using, send a lower case "n" matrix.

Fractions in German faces are always furnished to run in the pi box.

We carry in stock pine trays to hold a full set of matrices, which will be found very convenient for handling and storing sets of matrices not in actual use. These we supply at \$1.00 each.

Always state plainly how you wish goods shipped—whether by freight, express, or by mail; and if a special route is desired, name it. Otherwise we shall exercise our judgment.

It is important that supply orders should be sent either to one of the agencies or to the factory direct, not to the main office, New York.

Remember that unless your order is plain and in accordance with the above instructions, vexatious delays are liable to occur.

GENERAL INFORMATION

Prices of Matrices, Border Characters, etc.

KIND OF MATRIX	PRICE	
	PER SET	EACH
Standard One-letter Sets.....	\$40 00
Standard Two-letter Sets.....	66 00
Standard One-letter Sorts.....	\$0 03
Standard Two-letter Sorts.....	0 04½
Border Sets (26 in set).....	2 50
Border Sorts.....	0 10
Duplicate Character Sorts.....	0 08
Greek	0 08
Hair Spaces—Sizes .012 to .020.....	0 01
Riveted Sorts (Logotypes).....	0 16 up
Sectional One-letter Sorts, per Section..	0 03
Sectional Two-letter Sorts.....	0 04½
Two-line Sorts.....	0 03
Vertical Slug One-letter.....	0 03
Vertical Slug Two-letter.....	0 04½
Rogers Tabular Matrices.....	55 00	0 04½

One and two-letter sets in any face from 5-point to 14-point inclusive, if made up according to standard list, are \$40 and \$66 respectively per set; if changes are required an additional charge will be made.

DUPLICATE CHARACTER MATRICES are made with identically the same character in both positions and can be used in either upper or lower position in connection with one- and two-letter matrices, without shifting the line.

TWO-LINE MATRICES are used principally for initial letters and "ads.," casting on the first slug and overhanging the second. They can be used for head lines by casting them on an 11-point body.

SECTIONAL MATRICES are used for advertising work requiring large figures. The top section casts on the first slug and the bottom on the second; the two complete the character.

VERTICAL SLUG MATRICES have the character punched crosswise of the matrices and cast it horizontally on the slug, permitting the slug to be turned vertically to produce a column of figures in print.

RIVETED MATRICES represent two or more characters combined to produce a single character, logotype, or word. The charge for this style of matrix is 3 cents for each matrix composing the character and 10 cents additional for riveting. For two-letter the price is 4½ cents for each character and 10 cents for riveting.

GENERAL INFORMATION

HAIR SPACES are very thin spaces, grading in .001 of an inch from .012 to .020. They are similar in shape to the "en" and "em" spaces, but are inserted in the line by hand and automatically returned by the machine to the quad box. These should not be confounded with the regular thin spaces measuring .028, .031, .035, .0385, .042, and .049.

ACCENTED CAPITALS can be furnished reduced in height to cast on a regular body, or made full height to cast on a larger body, the increased thickness to go on the top of the slug, in which case a special mold is required.

Superior and Inferior Figures can be used for extended fractions, footnotes, powers, etc.

Should you return matrices to us at any time, please see that they are carefully assorted by font, face, and character—that is, put all A's together, all B's together, etc., of each font. By so doing you will save time and expense, as we invariably charge for this work.

If sets are required to be broken and other characters substituted in place of those regularly supplied, it will be done upon request. There will, however, be a charge of \$1 per font for doing this, as it entails extra labor and a second handling, as well as inspection and recounting.

BORDER MATRICES, to be assembled in lines and used in any Linotype machine in connection with the ordinary mold, do not demand the use of any extra parts in the machine. Order by number and note that the corner pieces have special numbers. Sets of 26 matrices, \$2.50; single matrices, 10 cents each.

MATRIX SLIDES, complete in one piece, are used in the machine with the regular mold. One quad block must be had to hold the slides, which are interchangeable and produce rules, dashes, and borders in great variety, in every way as perfect as those of brass. Quad blocks, 13½ to 30 ems, \$2.00; 13 ems and under, \$1.75. Matrix Slides, any pattern, 13½ to 30 ems, \$1.25; 13 ems and under, \$1.00.

SPACEBANDS are now made in three classes—thin, thick, and extra thick. The thin spacebands present a minimum thickness of .032 of an inch and expand to .095 of an inch. These are for use where very thin spacing is desired, as, for example, in connection with very small faces. Thick spacebands present a minimum thickness of .0375 of an inch and expand to .100 of an inch. These spacebands are most commonly used and are made for use with one- and two-letter matrices. Extra thick spacebands present a minimum thickness of .047 of an inch and expand to .147 of an inch. They are especially designed to save hand-spacing where large German matrices are used on narrow newspaper measure, and can also be used with 12-point faces, or where wide spacing is desired.

ROGERS TABULAR SYSTEM SPACEBANDS are made with an extra wide side to cover the slot in the matrices, and are sold at \$1.00 each. The regular spacebands cannot be used with Rogers Tabular Matrices.



***One-Letter
Faces***

MERGENTHALER LINOTYPE CO.

5½-POINT NO. 1

[ONE-LETTER]

Lower case alphabet 16.10 ems

THE MOST ancient materials employed for recording events were bricks, tiles, shells, and tables of stone. The modes of writing on these different substances were various. The tiles and bricks were impressed with a stamp when in a soft state; the shells or tablets of stone were etched or graven, the figures or characters being cut in their surface, and in some cases also stained with various colors. It was by the ancient art of stamping that the walls, palaces, and towers of Babylon were covered with hieroglyphics, which have but recently been brought to light from under the immense mounds of Mesopotamia by Layard and other explorers. The patriarch Job, who is supposed to have lived about 2,800 years after the creation, exclaimed, "O that my words were now written! O that they were printed in a book! that they were graven with an iron pen, and hid in the rock forever!" Stung with the unjust accusation of his friends, he desires to record his words that the

THE MOST ancient materials employed for recording events were bricks, tiles, shells, and tables of stone. The modes of writing on these different substances were various. The tiles and brick were impressed with a stamp when in a soft state; the shells or tablets of stone were etched or graven, the figures or characters being cut in their surface, and in some cases also stained with various colors. It was by the ancient art of stamping that the walls, palaces, and towers of Babylon were covered with hieroglyphics, which have but recently been brought to light from under the immense mounds of Mesopotamia by Layard and other explorers. The patriarch Job, who is supposed to have lived about 2,800 years after the creation, exclaimed, "O that my words were now written! O that they were printed in a book! that they were graven with an iron pen, and hid in the rock forever!" Stung by the unjust ac-

ABCDEFGHIJKLMNOPQRSTUVWXYZ

abcdefghijklmnpqrstuvwxy

1 2 3 4 5 6 7 8 9 0

¼ ½ ¾ ¼ ½ ¾ ¼

Special set table characters. Figures and figure space .046; double figure space .092; comma, period, and quotations .031. These sizes will be sent unless otherwise ordered.

Substitute table characters for use with this face can be had as follows: 5½-point No. 2.—Figures and en quad .0385; em quad .077; comma, period, and quotations .031. 5½-point Clarendon No. 1.—Figures and figure space .046; double figure space .092; comma, period, and quotations .031.

Alignment. This face aligns with all 5½-point one- and two-letter faces except German.
Will run in all machines.

To avoid errors read notice on page six

MERGENTHALER LINOTYPE CO.

6-POINT NO. 1

[ONE-LETTER]

Lower case alphabet 17.01 ems

THE MOST ancient materials employed for recording events were bricks, tiles, shells, and tables of stone. The modes of writing on these different substances were various. The tiles and brick were impressed with a stamp when in a soft state; the shells and tablets of stone were etched or graven, the figures or characters being cut in their surface, and in some cases also stained with various colors. It was by the ancient art of stamping that the walls, palaces, and towers of Babylon were covered with hieroglyphics, which have but recently been brought to light from under the immense mounds of Mesopotamia by Layard and other explorers. The patriarch Job, who is supposed to have lived about 2,300 years after the creation, exclaimed, "O that my words were now written! O that they were printed in a book! that they were graven with an iron pen, and

THE MOST ancient materials employed for recording events were bricks, tiles, shells, and tables of stone. The modes of writing on these different substances were various. The tiles and brick were impressed with a stamp when in a soft state; the shells and tablets of stone were etched or graven, the figures or characters being cut in their surface, and in some cases also stained with various colors. It was by the ancient art of stamping that the walls, palaces, and towers of Babylon were covered with hieroglyphics, which have but recently been brought to light from under the immense mounds of Mesopotamia by Layard and other explorers. The patriarch Job, who is supposed to have lived about 2,300 years after the creation,

ABCDEFGHIJKLMNOPQRSTUVWXYZ&

abcdefghijklmnopqrstuvwxyz

1 2 3 4 5 6 7 8 9 0

. . . : ! ? () * ' ' - . . . ñ ñ ñ ñ ñ ñ ñ @ £ \$ []

¼ ½ ¾ ¼ ½ ¾ ¼

Special set table characters. Figures and figure space .050; double figure space .100; comma, period, and quotations .031. These sizes will be sent unless otherwise ordered.

Substitute table characters for use with this face can be had as follows: 6-point Clarendon No. 1.—Figures and figure space .050; double figure space .100; comma, period, and quotations .031. 6-point No. 2.—Figures and en quad .042; em quad .084; comma, period, and quotations .031.

Alignment. This face aligns with all 6-point one- and two-letter faces except German.

Will run in all machines.

To avoid errors read notice on page six

MERGENTHALER LINOTYPE CO.

7-POINT NO. 1

[ONE-LETTER]

Lower case alphabet 15.63 ems

THE MOST ancient materials employed for recording events were bricks, tiles, shells, and tables of stone. The modes of writing on these different substances were various. The tiles and brick were impressed with a stamp when in a soft state; the shells and tablets of stone were etched or graven, the figures or characters, being cut in their surface and in some cases also stained with various colors. It was by the ancient art of stamping that the walls, palaces, and towers of Babylon were covered with hieroglyphics, which have but recently been brought to light from under the immense mounds of Mesopotamia by Layard and other explorers. The patriarch Job, who is supposed to have lived about 2,300 years after the creation, exclaimed, "O that

THE MOST ancient materials employed for recording events were bricks, tiles, shells, and tables of stone. The modes of writing on these different substances were various. The tiles and brick were impressed with a stamp when in a soft state; the shells and tablets of stone were etched or graven, the figures or characters being cut in their surface, and in some cases also stained with various colors. It was by the ancient art of stamping that the walls, palaces, and towers of Babylon were covered with hieroglyphics, which have but recently been brought to light from under the immense mounds of Mesopotamia by Layard and other explorers. The patriarch Job, who

ABCDEFGHIJKLMN O PQRSTU VWXYZ&

abcdefghijklmnopqrstuvwxyz

1 2 3 4 5 6 7 8 9 0

, . : ; ! ? () * ' ' - . . . ß ß ß ß ß ß @ £ \$ []

1/8 1/4 3/8 1/2 5/8 3/4 7/8

Special set table characters. Figures and figure space .099; double figure space .118; comma, period, and quotations .031. These sizes will be sent unless otherwise ordered.

Substitute table characters for use with this face can be had as follows: 7-point No. 2.—Figures and en quad .049; em quad .098; comma, period, and quotations .031.

Alignment. This face aligns with all 7-point one- and two-letter faces except German.

Will run in all machines.

To avoid errors read notice on page six

MERGENTHALER LINOTYPE CO.

8-POINT NO. 1

[ONE-LETTER]

Lower case alphabet 14.71 ems

THE MOST ancient materials employed for recording events were bricks, tiles, shells, and tables of stone. The modes of writing on these different substances were various. The tiles and brick were impressed with a stamp when in a soft state; the shells and tablets of stone were etched or graven, the figures or characters being cut in their surface, and in some cases also stained with various colors. It was by the ancient art of stamping that the walls, palaces, and towers of Babylon were covered with hieroglyphics, which have but recently been brought to light from under the immense mounds of Mesopotamia by Layard and other explorers. The patriarch Job, who is supposed to have lived about

THE MOST ancient materials employed for recording events were bricks, tiles, shells, and tables of stone. The modes of writing on these different substances were various. The tiles and brick were impressed with a stamp when in a soft state; the shells and tablets of stone were etched or graven, figures or characters being cut in their surface, and in some cases also stained with various colors. It was by the ancient art of stamping that the walls, palaces, and towers of Babylon were covered with hieroglyphics, which have but recently been brought to light from

ABCDEFGHIJKLMNOPQRSTUVWXYZ&

abcdefghijklmnopqrstuvwxyz

1 2 3 4 5 6 7 8 9 0

. . . ; ! ? () * ' ' - - . . . ñ ñ ñ ñ ñ ñ ñ @ £ \$ []

1/8 1/4 3/8 1/2 5/8 3/4 7/8

Special set table characters. Figures and figure space .059; double figure space .118; comma, period, and quotations .031. These sizes will be sent unless otherwise ordered.

Substitute table characters for use with this face can be had as follows: 8-point No. 2.—Figures and em quad .056; em quad .112; comma, period, and quotations .031. 8-point Clarendon No. 1.—Figures and figure space .059; double figure space .118; comma, period, and quotations .0295.

Alignment. This face aligns with all 8-point one- and two-letter faces having high alignment except German.

Will run in all machines.

To avoid errors read notice on page six

SPECIMENS OF LINOTYPE FACES

8-POINT NO. 1
One-Letter

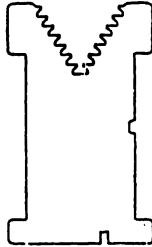

SPECIAL
CHARACTERS

Small Caps.

ABCDEFGHIJKLMN OPQRSTUVWXYZ&

High Cap Accents—These require a special mold.

À Á Â Ã Ä Å Ç È É Ê Ë Ì Í Î Ñ Ò Ó Ô Õ Ö × Ø Ù Ú Û Ü Ý Þ ß

Low Cap Accents—Regular mold may be used.

À Á Â Ã Ä Å Ç È É Ê Ë Ì Í Î Ñ Ò Ó Ô Õ Ö Ø Ù Ú Û Ü Ý Þ ß

Small Cap Accents.

À Á Â Ã Ä Å Ç È É Ê Ë Ì Í Î Ñ Ò Ó Ô Õ Ö Ø Ù Ú Û Ü Ý Þ ß

À Á Â Ã Ä Å Ç È É Ê Ë Ì Í Î Ñ Ò Ó Ô Õ Ö Ø Ù Ú Û Ü Ý Þ ß

À Á Â Ã Ä Å Ç È É Ê Ë Ì Í Î Ñ Ò Ó Ô Õ Ö Ø Ù Ú Û Ü Ý Þ ß

À Á Â Ã Ä Å Ç È É Ê Ë Ì Í Î Ñ Ò Ó Ô Õ Ö Ø Ù Ú Û Ü Ý Þ ß

À Á Â Ã Ä Å Ç È É Ê Ë Ì Í Î Ñ Ò Ó Ô Õ Ö Ø Ù Ú Û Ü Ý Þ ß

À Á Â Ã Ä Å Ç È É Ê Ë Ì Í Î Ñ Ò Ó Ô Õ Ö Ø Ù Ú Û Ü Ý Þ ß

À Á Â Ã Ä Å Ç È É Ê Ë Ì Í Î Ñ Ò Ó Ô Õ Ö Ø Ù Ú Û Ü Ý Þ ß

À Á Â Ã Ä Å Ç È É Ê Ë Ì Í Î Ñ Ò Ó Ô Õ Ö Ø Ù Ú Û Ü Ý Þ ß

À Á Â Ã Ä Å Ç È É Ê Ë Ì Í Î Ñ Ò Ó Ô Õ Ö Ø Ù Ú Û Ü Ý Þ ß

À Á Â Ã Ä Å Ç È É Ê Ë Ì Í Î Ñ Ò Ó Ô Õ Ö Ø Ù Ú Û Ü Ý Þ ß

À Á Â Ã Ä Å Ç È É Ê Ë Ì Í Î Ñ Ò Ó Ô Õ Ö Ø Ù Ú Û Ü Ý Þ ß

À Á Â Ã Ä Å Ç È É Ê Ë Ì Í Î Ñ Ò Ó Ô Õ Ö Ø Ù Ú Û Ü Ý Þ ß

À Á Â Ã Ä Å Ç È É Ê Ë Ì Í Î Ñ Ò Ó Ô Õ Ö Ø Ù Ú Û Ü Ý Þ ß

À Á Â Ã Ä Å Ç È É Ê Ë Ì Í Î Ñ Ò Ó Ô Õ Ö Ø Ù Ú Û Ü Ý Þ ß

À Á Â Ã Ä Å Ç È É Ê Ë Ì Í Î Ñ Ò Ó Ô Õ Ö Ø Ù Ú Û Ü Ý Þ ß

À Á Â Ã Ä Å Ç È É Ê Ë Ì Í Î Ñ Ò Ó Ô Õ Ö Ø Ù Ú Û Ü Ý Þ ß

À Á Â Ã Ä Å Ç È É Ê Ë Ì Í Î Ñ Ò Ó Ô Õ Ö Ø Ù Ú Û Ü Ý Þ ß

À Á Â Ã Ä Å Ç È É Ê Ë Ì Í Î Ñ Ò Ó Ô Õ Ö Ø Ù Ú Û Ü Ý Þ ß

À Á Â Ã Ä Å Ç È É Ê Ë Ì Í Î Ñ Ò Ó Ô Õ Ö Ø Ù Ú Û Ü Ý Þ ß

À Á Â Ã Ä Å Ç È É Ê Ë Ì Í Î Ñ Ò Ó Ô Õ Ö Ø Ù Ú Û Ü Ý Þ ß

À Á Â Ã Ä Å Ç È É Ê Ë Ì Í Î Ñ Ò Ó Ô Õ Ö Ø Ù Ú Û Ü Ý Þ ß

À Á Â Ã Ä Å Ç È É Ê Ë Ì Í Î Ñ Ò Ó Ô Õ Ö Ø Ù Ú Û Ü Ý Þ ß

À Á Â Ã Ä Å Ç È É Ê Ë Ì Í Î Ñ Ò Ó Ô Õ Ö Ø Ù Ú Û Ü Ý Þ ß

À Á Â Ã Ä Å Ç È É Ê Ë Ì Í Î Ñ Ò Ó Ô Õ Ö Ø Ù Ú Û Ü Ý Þ ß

À Á Â Ã Ä Å Ç È É Ê Ë Ì Í Î Ñ Ò Ó Ô Õ Ö Ø Ù Ú Û Ü Ý Þ ß

À Á Â Ã Ä Å Ç È É Ê Ë Ì Í Î Ñ Ò Ó Ô Õ Ö Ø Ù Ú Û Ü Ý Þ ß

À Á Â Ã Ä Å Ç È É Ê Ë Ì Í Î Ñ Ò Ó Ô Õ Ö Ø Ù Ú Û Ü Ý Þ ß

À Á Â Ã Ä Å Ç È É Ê Ë Ì Í Î Ñ Ò Ó Ô Õ Ö Ø Ù Ú Û Ü Ý Þ ß

À Á Â Ã Ä Å Ç È É Ê Ë Ì Í Î Ñ Ò Ó Ô Õ Ö Ø Ù Ú Û Ü Ý Þ ß

À Á Â Ã Ä Å Ç È É Ê Ë Ì Í Î Ñ Ò Ó Ô Õ Ö Ø Ù Ú Û Ü Ý Þ ß

À Á Â Ã Ä Å Ç È É Ê Ë Ì Í Î Ñ Ò Ó Ô Õ Ö Ø Ù Ú Û Ü Ý Þ ß

À Á Â Ã Ä Å Ç È É Ê Ë Ì Í Î Ñ Ò Ó Ô Õ Ö Ø Ù Ú Û Ü Ý Þ ß

MERGENTHALER LINOTYPE CO.

10-POINT NO. 1

[ONE-LETTER]

Lower case alphabet 13.63 ems

THE MOST ancient materials employed for recording events were bricks, tiles, shells, and tables of stone. The modes of writing on these different substances were various. The tiles and brick were impressed with a stamp when in a soft state; the shells and tablets of stone were etched or graven, the figures or characters being cut in their surface, and in some cases also stained with various colors. It was by the ancient art of stamping that the walls, palaces, and towers of Babylon were covered with hiero-

THE MOST ancient materials used for recording events were bricks, tiles, shells, and tables of stone. The modes of writing on these different substances were various. The tiles and brick were impressed with a stamp when in a soft state; the shells and tablets of stone were etched or graven, the figures or characters being cut in their surface and in some cases stained with various colors. It was by

ABCDEFGHIJKLMNOPQRSTUVWXYZ&

abcdefghijklmnopqrstuvwxyz

1 2 3 4 5 6 7 8 9 0

, . : ; ! ? (|) * ' ' - . . . fi ff fl ll lb @ \$ £ []

1/8 1/4 3/8 1/2 5/8 3/4 7/8

True set table characters. Figures and en quad .070; em quad .140; comma, period, and quotations .035. These sizes will be sent unless otherwise ordered.

Substitute table characters for use with this face can be had as follows: 10-point No. 13.—Figures and en quad .070; em quad .140; comma, period, and quotations .035. 10-point Clarendon No. 1.—Figures and en quad .070; em quad .140; comma, period, and quotations .035.

Alignment. This face aligns with all 10-point one- and two-letter faces except German.

Will run in all machines.

To avoid errors read notice on page six

MERGENTHALER LINOTYPE CO.

11-POINT NO. 1

[ONE-LETTER]

Lower case alphabet 13.53 ems

THE MOST ancient materials employed for recording events were bricks, tiles, shells, and tables of stone. The modes of writing on these different substances were various. The tiles and brick were impressed with a stamp when in a soft state; the shells and tablets of stone were etched or graven, the figures or characters being cut in their surface, and in some cases also stained with various colors. It was by the ancient art of stamping that the walls, palaces,

THE MOST ancient materials used for recording events were bricks, tiles, shells, and tables of stone. The tiles and brick were impressed with a stamp when in a soft state; the shells and tablets of stone were etched or graven the figures or characters being cut in their surface, and in some cases also stained with various colors. It was by the ancient art of

ABCDEFGHIJKLMNOPQRSTUVWXYZ&

abcdefghijklmnopqrstuvwxyz

1 2 3 4 5 6 7 8 9 0

, . : ; ! ? () * ' - — . . . fi ff ffi ffl lb @ £ \$ []

1/8 1/4 3/8 1/2 5/8 3/4 7/8

True set table characters. Figures and en quad .077; em quad .154; comma, period, and quotations .0385. These sizes will be sent unless otherwise ordered.

Alignment. This face aligns with all 11-point one and two-letter faces except German.

Will run in all machines.

To avoid errors read notice on page six

MERGENTHALER LINOTYPE CO.

5½-POINT NO. 2

[ONE-LETTER]

THE most ancient materials employed for recording events were bricks, tiles, shells, and tables of stone. The modes of writing on these different substances were various. The tiles, and bricks were impressed with a stamp when in a soft state; the shells and tablets of stone were etched or graven, the figures or characters being cut in their surface, and in some cases also stained with various colors. It was by the ancient art of stamping that the walls, palaces, and towers of Babylon were covered with hieroglyphics, which have but recently been brought to light from under the immense mounds of Mesopotamia by Layard and other explorers. The patriarch Job, who is supposed to have lived about 2,300 years after the creation, exclaimed, "O that my words were now written! O that they were printed in a book! that they were graven with an iron pen and hidden in the rock forever!" Stung with the unjust accusation

THE most ancient materials employed for recording events were bricks, tiles, shells, and tables of stone. The modes of writing on these different substances were various. The tiles and brick were impressed with a stamp when in a soft state; the shells and tablets of stone were etched or graven, the figures or characters being cut in their surface, and in some cases also stained with various colors. It was by the ancient art of stamping that the walls, palaces, and towers of Babylon were covered with hieroglyphics, which have but recently been brought to light from under the immense mounds of Mesopotamia by Layard and other explorers. The patriarch Job, who is supposed to have lived about 2,300 years after the creation, exclaimed, "O that my words were now written! O that they were printed in a book! that they were graven with an iron pen, and hid in the

ABCDEFGHIJKLMN OPQRSTUVWXYZ&

abcdefghijklmnopqrstuvwxyz

1 2 3 4 5 6 7 8 9 0

. . . ; ! ? (|) ' ' * - - . . . ñ ñ ñ ñ ñ ñ @ £ \$ []

½ ¼ ⅓ ¼ ⅕ ⅙ ⅚

True set table characters. Figures and en quad .0385; em quad .077; comma, period, and quotations .031. These sizes will be sent unless otherwise ordered.

Substitute table characters for use with this face can be had as follows: 5½-point No. 1.—Figures and figure space .046; double figure space .092; comma, period, and quotations .031. 5½-point Clarendon No. 1.—Figures and figure space .046; double figure space .092; comma, period, and quotations .031.

Alignment. This face aligns with all 5½-point one- and two-letter faces except German.

Will run in all machines.

To avoid errors read notice on page six

MERGENTHALER LINOTYPE CO.

6-POINT NO. 2

[ONE-LETTER]

Lower case alphabet 17.63 ems

THE MOST ancient materials employed for recording events were bricks, tiles, shells, and tables of stone. The modes of writing on these different substances were various. The tiles and brick were impressed with a stamp when in a soft state; the shells and tablets of stone were etched or graven, the figures or characters being cut in their surface, and in some cases also stained with various colors. It was by the ancient art of stamping that the walls, palaces, and towers of Babylon were covered with hieroglyphics, which have but recently been brought to light from under the immense mounds of Mesopotamia by Layard and other explorers. The patriarch Job, who is supposed to have lived about 2,300 years after the creation, exclaimed, "O that my words were now written! O that they were printed in a book!

THE MOST ancient materials employed for recording events were bricks, tiles, shells, and tables of stone. The modes of writing on these different substances were many. The tiles and brick were impressed with a stamp when in a soft state; the shells and tablets of stone were etched or graven, the figures or characters being cut in their surface, and in some cases stained with various colors. It was by the ancient art of stamping that the walls, palaces, and towers of Babylon were covered with hieroglyphics, which have but recently been brought to light from under the immense mounds of Mesopotamia by Layard and other explorers. The patriarch Job, who is supposed to have lived about 2,300

ABCDEFGHIJKLMNOPQRSTUVWXYZ&

abcdefghijklmnopqrstuvwxyz

1 2 3 4 5 6 7 8 9 0

, . : ; ! ? (|) * ' ' - - . . . ñ ñ ñ ñ ñ ñ ñ ñ @ £ \$ []

¼ ½ ¾ ¼ ½ ¾

True set table characters. Figures and en quad .042; em quad .084; comma, period, and quotations .031. These sizes will be sent unless otherwise ordered.

Substitute table characters for use with this face can be had as follows:
 6-point No. 1.—Figures and figure space .050; double figure space .100; comma, period, and quotations .031. 6-point Clarendon No. 1.—Figures and figure space .050; double figure space .100; comma, period, and quotations .031.

Alignment. This face aligns with all 6-point one- and two-letter faces except German.

Will run in all machines.

To avoid errors read notice on page six

MERGENTHALER LINOTYPE CO.

7-POINT NO. 2

[ONE-LETTER]

Lower case alphabet 16.41 ems

THE MOST ancient materials used for recording events were bricks, tiles, shells, and tables of stone. The modes of writing on these different substances were various. The tiles and brick were impressed with a stamp when in a soft state; the shells and tablets of stone were etched or graven, the figures or characters being cut in their surface and in some cases also stained with various colors. It was by the ancient art of stamping that the walls, palaces, and towers of Babylon were covered with hieroglyphics, which have but recently been brought to light from under the immense mounds of Mesopotamia by Layard and other explorers. The patriarch Job, who is supposed to have lived about 2,300 years after the creation, exclaimed, "O that my words were

THE MOST ancient materials employed for recording events were bricks, tiles, shells, and tables of stone. The modes of writing on these different substances were various. The tiles and brick were impressed with a stamp when in a soft state; the shells and tablets of stone were etched or graven, the figures or characters being cut in their surface, and in some cases also stained with various colors. It was by the ancient art of stamping that the walls, palaces, and towers of Babylon were covered with hieroglyphics which have but recently been brought to light from under the immense mounds of Meso-

ABCDEFGHIJKLMN OPQRSTUVWXYZ&

abcdefghijklmnopqrstuvwxyz

1 2 3 4 5 6 7 8 9 0

\$ £ ¢ @ & [] ¼ ½ ¾ ⅝ ⅞

, . : ; ? ! (|) * - - ' ' . . . fi ff ffi ffi

True set table characters. Figures and en quad .049; em quad .098; comma, period, and quotations .031. These sizes will be sent unless otherwise ordered.

Substitute table characters for use with this face can be had as follows: 7-point No. 1.—Figures and figure space .059; double figure space .118; comma, period, and quotations .031.

Alignment. This face aligns with all 7-point one- and two-letter faces except German.

Will run in all machines.

To avoid errors read notice on page six

MERGENTHALER LINOTYPE CO.

8-POINT NO. 2

[ONE-LETTER]

Lower case alphabet 14.38 ems

THE MOST ancient materials used for recording events were bricks, tiles, shells, and tables of stone. The modes of writing on these different substances were various. The tiles and brick were impressed with a stamp when in a soft state; the shells and tablets of stone were etched or graven, the figures or characters being cut in their surface, and in some cases also stained with various colors. It was by the ancient art of stamping that the walls, palaces, and towers of Babylon were covered with hieroglyphics, which have but recently been brought to light from under the immense mounds of Mesopotamia by Layard and other explorers. The patriarch Job, who is supposed to have lived about 2,300 years after the creation, exclaimed, "O that my words were

THE MOST ancient materials employed for recording events were bricks, tiles, shells, and tables of stone. The modes of writing on these different substances were various. The tiles and brick were impressed with a stamp when in a soft state; the shells and tablets of stone were etched or graven, the figures or characters being cut in their surface, and in some cases also stained with various colors. It was by the ancient art of stamping that the walls, palaces, and towers of Babylon were covered with hieroglyphics, which have but recently been brought to light from un-

ABCDEFGHIJKLMN O P Q R S T U V W X Y Z &

abcdefghijklmnopqrstuvwxyz

1 2 3 4 5 6 7 8 9 0

, . : ; ! ? (|) * - — ‘ ’ . . . fi fl ff fl fl lb @ £ \$ []

1/8 1/4 3/8 1/2 5/8 3/4 7/8

True set table characters. Figures and en quad .056; em quad .112; comma, period, and quotations .031. These sizes will be sent unless otherwise ordered.

Substitute table characters for use with this face can be had as follows: 8-point No. 1.—Figures and figure space .059; double figure space .118; comma, period, and quotations .031. 8-point Clarendon No. 1.—Figures and figure space .059; double figure space .118; comma, period, and quotations .0295.

Alignment. This face aligns with all 8-point one- and two-letter faces having high alignment except German.

Will run in all machines.

To avoid errors read notice on page six

SPECIMENS OF LINOTYPE FACES

8-POINT NO. 2
One-Letter

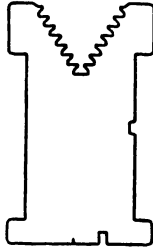

SPECIAL
CHARACTERS

Superior Caps in Auxiliary Position: B F G H I J K M N O P T U V W X Z
Small Caps.

ABCDEFGHIJKLMN O P Q R S T U V W X Y Z &

High Cap Accents—These require a special mold.

À Á Â Ã Ç È É Ê Ë Ì Í Î Ï Ñ Ò Ó Ô Õ Ö × Ø Ù Ú Û Ü Ý Þ ß

Low Cap Accents—Regular mold may be used.

À Á Â Ã Ä Å Ç È É Ê Ë Ì Í Î Ï Ñ Ò Ó Ô Õ Ö Ø Ù Ú Û Ü Ý Þ ß

Small Cap Accents.

À Á Â Ã Ä Å Æ Ç È É Ê Ë Ì Í Î Ï Ñ Ò Ó Ô Õ Ö × Ø Ù Ú Û Ü Ý Þ ß

À Á Â Ã Ä Å Æ Ç È É Ê Ë Ì Í Î Ï Ñ Ò Ó Ô Õ Ö × Ø Ù Ú Û Ü Ý Þ ß

À Á Â Ã Ä Å Æ Ç È É Ê Ë Ì Í Î Ï Ñ Ò Ó Ô Õ Ö × Ø Ù Ú Û Ü Ý Þ ß

À Á Â Ã Ä Å Æ Ç È É Ê Ë Ì Í Î Ï Ñ Ò Ó Ô Õ Ö × Ø Ù Ú Û Ü Ý Þ ß

À Á Â Ã Ä Å Æ Ç È É Ê Ë Ì Í Î Ï Ñ Ò Ó Ô Õ Ö × Ø Ù Ú Û Ü Ý Þ ß

À Á Â Ã Ä Å Æ Ç È É Ê Ë Ì Í Î Ï Ñ Ò Ó Ô Õ Ö × Ø Ù Ú Û Ü Ý Þ ß

À Á Â Ã Ä Å Æ Ç È É Ê Ë Ì Í Î Ï Ñ Ò Ó Ô Õ Ö × Ø Ù Ú Û Ü Ý Þ ß

À Á Â Ã Ä Å Æ Ç È É Ê Ë Ì Í Î Ï Ñ Ò Ó Ô Õ Ö × Ø Ù Ú Û Ü Ý Þ ß

À Á Â Ã Ä Å Æ Ç È É Ê Ë Ì Í Î Ï Ñ Ò Ó Ô Õ Ö × Ø Ù Ú Û Ü Ý Þ ß

À Á Â Ã Ä Å Æ Ç È É Ê Ë Ì Í Î Ï Ñ Ò Ó Ô Õ Ö × Ø Ù Ú Û Ü Ý Þ ß

À Á Â Ã Ä Å Æ Ç È É Ê Ë Ì Í Î Ï Ñ Ò Ó Ô Õ Ö × Ø Ù Ú Û Ü Ý Þ ß

À Á Â Ã Ä Å Æ Ç È É Ê Ë Ì Í Î Ï Ñ Ò Ó Ô Õ Ö × Ø Ù Ú Û Ü Ý Þ ß

À Á Â Ã Ä Å Æ Ç È É Ê Ë Ì Í Î Ï Ñ Ò Ó Ô Õ Ö × Ø Ù Ú Û Ü Ý Þ ß

À Á Â Ã Ä Å Æ Ç È É Ê Ë Ì Í Î Ï Ñ Ò Ó Ô Õ Ö × Ø Ù Ú Û Ü Ý Þ ß

À Á Â Ã Ä Å Æ Ç È É Ê Ë Ì Í Î Ï Ñ Ò Ó Ô Õ Ö × Ø Ù Ú Û Ü Ý Þ ß

À Á Â Ã Ä Å Æ Ç È É Ê Ë Ì Í Î Ï Ñ Ò Ó Ô Õ Ö × Ø Ù Ú Û Ü Ý Þ ß

À Á Â Ã Ä Å Æ Ç È É Ê Ë Ì Í Î Ï Ñ Ò Ó Ô Õ Ö × Ø Ù Ú Û Ü Ý Þ ß

À Á Â Ã Ä Å Æ Ç È É Ê Ë Ì Í Î Ï Ñ Ò Ó Ô Õ Ö × Ø Ù Ú Û Ü Ý Þ ß

À Á Â Ã Ä Å Æ Ç È É Ê Ë Ì Í Î Ï Ñ Ò Ó Ô Õ Ö × Ø Ù Ú Û Ü Ý Þ ß

À Á Â Ã Ä Å Æ Ç È É Ê Ë Ì Í Î Ï Ñ Ò Ó Ô Õ Ö × Ø Ù Ú Û Ü Ý Þ ß

À Á Â Ã Ä Å Æ Ç È É Ê Ë Ì Í Î Ï Ñ Ò Ó Ô Õ Ö × Ø Ù Ú Û Ü Ý Þ ß

À Á Â Ã Ä Å Æ Ç È É Ê Ë Ì Í Î Ï Ñ Ò Ó Ô Õ Ö × Ø Ù Ú Û Ü Ý Þ ß

À Á Â Ã Ä Å Æ Ç È É Ê Ë Ì Í Î Ï Ñ Ò Ó Ô Õ Ö × Ø Ù Ú Û Ü Ý Þ ß

À Á Â Ã Ä Å Æ Ç È É Ê Ë Ì Í Î Ï Ñ Ò Ó Ô Õ Ö × Ø Ù Ú Û Ü Ý Þ ß

À Á Â Ã Ä Å Æ Ç È É Ê Ë Ì Í Î Ï Ñ Ò Ó Ô Õ Ö × Ø Ù Ú Û Ü Ý Þ ß

À Á Â Ã Ä Å Æ Ç È É Ê Ë Ì Í Î Ï Ñ Ò Ó Ô Õ Ö × Ø Ù Ú Û Ü Ý Þ ß

À Á Â Ã Ä Å Æ Ç È É Ê Ë Ì Í Î Ï Ñ Ò Ó Ô Õ Ö × Ø Ù Ú Û Ü Ý Þ ß

À Á Â Ã Ä Å Æ Ç È É Ê Ë Ì Í Î Ï Ñ Ò Ó Ô Õ Ö × Ø Ù Ú Û Ü Ý Þ ß

À Á Â Ã Ä Å Æ Ç È É Ê Ë Ì Í Î Ï Ñ Ò Ó Ô Õ Ö × Ø Ù Ú Û Ü Ý Þ ß

À Á Â Ã Ä Å Æ Ç È É Ê Ë Ì Í Î Ï Ñ Ò Ó Ô Õ Ö × Ø Ù Ú Û Ü Ý Þ ß

À Á Â Ã Ä Å Æ Ç È É Ê Ë Ì Í Î Ï Ñ Ò Ó Ô Õ Ö × Ø Ù Ú Û Ü Ý Þ ß

À Á Â Ã Ä Å Æ Ç È É Ê Ë Ì Í Î Ï Ñ Ò Ó Ô Õ Ö × Ø Ù Ú Û Ü Ý Þ ß

MERGENTHALER LINOTYPE CO.

5½-POINT NO. 3

[ONE-LETTER]

Lower case alphabet 15.32 ems

THE MOST ancient materials used for recording events were bricks, tiles, shells, and tables of stone. The modes of writing on these different substances were various. The tiles and bricks were impressed with a stamp when in a soft state; the shells and tablets of stone were etched or graven, the figures or characters being cut in their surface, and in some cases also stained with various colors. It was by the ancient art of stamping that the walls, palaces, and towers of Babylon were covered with hieroglyphics, which have but recently been brought to light from under the immense mounds of Mesopotamia by Layard and other explorers. The patriarch Job, who is supposed to have lived about 2,300 years after the creation, exclaimed, "O that my words were now written! O that they were printed in a book! that they were graven with an iron pen, and hid in the rock forever!" Stung with the unjust accusation of his friends, he desires to record his words that the generations following might see the justice of his cause. The English translation has given the allusion to

THE MOST ancient materials employed for recording events were bricks, tiles, shells, and tables of stone. The modes of writing on these different substances were various. The tiles and brick were impressed with a stamp when in a soft state; the shells and tablets of stone were etched or graven, the figures or characters being cut in their surface, and in some cases also stained with various colors. It was by the ancient art of stamping that the walls, palaces, and towers of Babylon were covered with hieroglyphics, which have but recently been brought to light from under the immense mounds of Mesopotamia by Layard and other explorers. The patriarch Job, who is supposed to have lived about 2,300 years after the creation, exclaimed, "O that my words were now written! O that they were printed in a book! that they were graven with an iron pen, and hid in the rock forever!" Stung with the unjust accusation of his friends, he desires to record his words that the generations following might see the justice of his

ABCDEFGHIJKLMNOPQRSTUVWXYZ&

abcdefghijklmnopqrstuvwxyz

1 2 3 4 5 6 7 8 9 0

. . . : ! ? () ' * - - . . . n n n m m m b @ f []

. ¼ ¼ ¼ ½ ½ ½

True set table characters. Figures and en quad .0385; em quad .077; comma, period, and quotations .031. These sizes will be sent unless otherwise ordered.

Substitute table characters for use with this face can be had as follows: 5½point No. 1.—Figures and figure space .046; double figure space .092; comma, period, and quotations .031. 5¼-point Clarendon No. 1.—Figures and figure space .046; double figure space .092; comma, period, and quotations .031.

Alignment. This face aligns with all 5½-point one- and two-letter faces except German.

Will run in all machines.

To avoid errors read notice on page six

MERGENTHALER LINOTYPE CO.

6-POINT NO. 3

[ONE-LETTER]

Lower case alphabet 16.1 ems

THE MOST ancient materials used for recording events were bricks, tiles, shells, and tables of stone. The modes of writing on these different substances were various. The tiles and brick were impressed with a stamp when in a soft state; the shells and tablets of stone were etched or graven, the figures or characters being cut in their surface, and in some cases also stained with various colors. It was by the ancient art of stamping that the walls, palaces, and towers of Babylon were covered with hieroglyphics, which have but recently been brought to light from under the immense mounds of Mesopotamia by Layard and other explorers. The patriarch Job, who is supposed to have lived about 2,300 years after the creation, exclaimed, "O that my words were now written! O that they were printed in a book!

THE MOST ancient materials employed for recording events were bricks, tiles, shells, and tables of stone. The modes of writing on these different substances were various. The tiles and brick were impressed with a stamp when in a soft state; the shells and tablets of stone were etched or graven, the figures or characters being cut in their surface, and in some cases also stained with various colors. It was by the ancient art of stamping that the walls and towers of Babylon were covered with hieroglyphics, which have recently been brought to light from under the great mounds of Mesopotamia by Layard and other explorers. The patriarch Job, who lived 2,300 years after the creation, exclaimed, "O that my words were now written! O that they

ABCDEFGHIJKLMNOPQRSTUVWXYZ&

abcdefghijklmnopqrstuvwxyz

1 2 3 4 5 6 7 8 9 0

. . . : ! ? (|) ' ' * - - . . . n n n m m n @ £ \$ []

¼ ¼ ¼ ¼ ¼ ¼

True set table characters. Figures and en quad .042; em quad .084; comma, period, and quotations .031. These sizes will be sent unless otherwise ordered.

Substitute table characters for use with this face can be had as follows:
 6-point No. 1.—Figures and figure space .050; double figure space .100; comma, period, and quotations .031. 6-point Clarendon No. 1.—Figures and figure space .050; double figure space .100; comma, period, and quotations .031.

Alignment. This face aligns with all 6-point one- and two-letter faces except German.

Will run in all machines.

To avoid errors read notice on page six

MERGENTHALER LINOTYPE CO.

7-POINT NO. 3

[ONE-LETTER]

Lower case alphabet 15.09 ems

THE MOST ancient materials employed for recording events were bricks, tiles, shells, and tables of stone. The modes of writing on these different substances were various. The tiles and brick were impressed with a stamp when in a soft state; the shells and tablets of stone were etched or graven, the figures or characters being cut in their surface, and in some cases also stained with various colors. It was by the ancient art of stamping that the walls, palaces, and towers of Babylon were covered with hieroglyphics, which have but recently been brought to light from under the immense mounds of Mesopotamia by Layard and other explorers. The patriarch Job, who is supposed to have lived about 2,300 years after the creation, exclaimed, "O that my words were now written! O that they were printed in a book! that they were graven with an iron pen, and hid in the rock forever!"

THE MOST ancient materials employed for recording events were bricks, tiles, shells, and tables of stone. The modes of writing on these different substances were various. The tiles and brick were impressed with a stamp when in a soft state; the shells and tablets of stone were etched or graven, the figures or characters being cut in their surface, and in some cases also stained with various colors. It was by the ancient art of stamping that the walls, palaces, and towers of Babylon were covered with hieroglyphics, which have but recently been brought to light from under the immense mounds of Mesopotamia by Layard and other explorers. The patriarch Job, who is supposed to have lived about 2,300

ABCDEFGHIJKLMNOPQRSTUVWXYZ&

abcdefghijklmnopqrstuvwxyz

1 2 3 4 5 6 7 8 9 0

, . : ; ! ? () * ' ' - — . . . ñ ñ ñ ñ ñ ñ @ £ \$ []

¼ ½ ¾

True set table characters. Figures and en quad .049; em quad .098; comma, period, and quotations .031. These sizes will be sent unless otherwise ordered.

Substitute table characters for use with this face can be had as follows: 7-point No. 1.—Figures and figure space .059; double figure space .118; comma, period, and quotations .031.

Alignment. This face aligns with all 7-point one- and two-letter faces except German.

Will run in all machines.

To avoid errors read notice on page six

MERGENTHALER LINOTYPE CO.

8-POINT NO. 4

[ONE-LETTER]

Lower case alphabet 14.94 ems

THE MOST ancient materials used for recording events were bricks, tiles, shells, and tables of stone. The modes of writing on these different substances were various. The tiles and brick were impressed when in a soft state; the shells and tablets of stone were etched or graven, the figures or characters being cut in their surface, and in some cases also stained with various colors. It was by the ancient art of stamping that the walls, palaces, and towers of Babylon were covered with hieroglyphics, which have but recently been brought to light from under the immense mounds of Mesopotamia by Layard and other explorers. The patriarch Job, who is supposed to have lived about 2,300 years after the creation, exclaimed, "O that my words were now

THE MOST ancient materials employed for recording events were bricks, tiles, shells, and tables of stone. The modes of writing on these different articles were various. The tiles and brick were impressed with a stamp when in a soft state; the shells and tablets of stone were etched or graven, the figures or characters being cut in their surface, and sometimes also stained with various colors. It was by the ancient art of stamping that the walls, palaces, and towers of Babylon were covered with hieroglyphics, which have but recently been brought to light from under the immense mounds

ABCDEFGHIJKLMNOPQRSTUVWXYZ&

abcdefghijklmnopqrstuvwxyz

1 2 3 4 5 6 7 8 9 0

, . : ; ! ? () * - ' ' . . . fi fl ff ffi fb @ £ \$ []

1/8 1/4 3/8 1/2 5/8 3/4 %

True set table characters. Figures and en quad .056; em quad .112; comma, period, and quotations .031. These sizes will be sent unless otherwise ordered.

Substitute table characters for use with this face can be had as follows:
8-point No. 1.—Figures and figure space .059; double figure space .118; comma, period, and quotations .031. 8-point Clarendon No. 1.—Figures and figure space .059; double figure space .118; comma, period, and quotations .0295.

Alignment. This face aligns with all 8-point one- and two-letter faces having high alignment except German.

Will run in all machines.

To avoid errors read notice on page six

MERGENTHALER LINOTYPE CO.

11-POINT NO. 9
[ONE-LETTER]

Lower case alphabet 11.96 ems

THE MOST ancient materials employed for recording events were bricks, tiles, shells, and tables of stone. The modes of writing on these different substances were various. The tiles and brick were impressed with a stamp when in a soft state; the shells and tablets of stone were etched or graven the figures or characters being cut in their surface, and in some cases also stained with various colors. It was by the ancient art of stamping that the walls, palaces, and towers of

THE MOST ancient materials used for recording events were bricks, tiles, shells, and tables of stone. The modes of writing on these different substances were various. The tiles and brick were impressed with a stamp when in a soft state; the shells and tablets of stone were etched or graven, the figures or characters being cut in their surface, and in some cases also stained

ABCDEFGHIJKLMN OPQRSTUVWXYZ &

abcdefghijklmnopqrstuvwxyz

1 2 3 4 5 6 7 8 9 0

, . : ; ! ? (|) * ' ' - — . . . fi fl ff ffi ffl lb @ £ \$ []

1/8 1/4 3/8 1/2 5/8 3/4 7/8

True set table characters. Figures and en quad .077; em quad .154; comma, period, and quotations .0385. These sizes will be sent unless otherwise ordered.

Alignment. This face aligns with all 11-point one and two-letter faces except German.

Will run in all machines.

To avoid errors read notice on page six

MERGENTHALER LINOTYPE CO.

6-POINT NO. 12 [ONE-LETTER]

Lower case alphabet 14.5 ems

THE MOST ancient materials employed for recording events were bricks, tiles, shells, and tables of stone. The modes of writing on these different substances were various. The tiles and brick were impressed with a stamp when in a soft state; the shells and tablets of stone were etched or graven, the figures or characters being cut in their surface, and in some cases also stained with various colors. It was by the ancient art of stamping that the walls, palaces, and towers of Babylon were covered with hieroglyphics, which have but recently been brought to light from under the immense mounds of Mesopotamia by Layard and other explorers. The patriarch Job, who is supposed to have lived about 2,300 years after the creation, exclaimed, "O that my words were now written! O that they were printed in a book! that they were graven with an iron pen and hid in the rock forever!" Stung with the unjust accusation of his friends, he desires to record his words that the generations following might see the justice of his cause. The English translation has given the allusion to printing to the text,

THE MOST ancient materials employed for recording events were bricks, tiles, shells, and tables of stone. The modes of writing on these different substances were various. The tiles and brick were impressed with a stamp when in a soft state; the shells and tablets of stone were etched or graven, the figures or characters being cut in their surface, and in some cases also stained with various colors. It was by the ancient art of stamping that the walls, towers, and palaces of Babylon were covered with hieroglyphics, which have but recently been brought to light from under the immense mounds of Mesopotamia by Layard and other explorers. The patriarch Job, who is supposed to have lived about 2,300 years after the creation, exclaimed, "O that my words were now written! O that they were printed in a book! that they were graven with an iron pen, and hid in the rock forever!" Stung with the unjust accusation of his friends, he desires to record his words that the generations following

ABCDEFGHIJKLMN O PQRST UVWXYZ &
 abcdefghijklmnopqrstuvwxy z
 1 2 3 4 5 6 7 8 9 0

. . . ; ! ? (|) * ' ' - . . . ß ſ ſ ſ ſ ſ ſ ſ @ £ \$ []
 ¼ ½ ¾ ¼ ½ ¾

True set table characters. Figures and en quad .042; em quad .084; comma, period, and quotations .031. These sizes will be sent unless otherwise ordered.

Substitute table characters for use with this face can be had as follows:
 6-point No. 1.—Figures and figure space .050; double figure space .100; comma, period, and quotations .031. 6-point Clarendon No. 1.—Figures and figure space .050; double figure space .100; comma, period, and quotations .031.

Alignment. This face aligns with all 6-point one- and two-letter faces except German.

Will run in all machines.

To avoid errors read notice on page six

MERGENTHALER LINOTYPE CO.

9-POINT NO. 13 (OLD ALIGNMENT) [ONE-LETTER]

Lower case alphabet 13.36 ems

THE MOST ancient materials employed for recording events were bricks, tiles, shells, and tables of stone. The modes of writing on these different substances were various. The tiles and brick were impressed with a stamp when in a soft state; the shells and tablets of stone were etched or graven, the figures or characters being cut in their surface, and in some cases also stained with various colors. It was by the ancient art of stamping that the walls, palaces, and towers of Babylon were covered with hieroglyphics, which have but recently been brought to light from under the immense mounds of Mesopotamia by Layard and other explorers. The patriarch Job, who is supposed to have

THE MOST ancient materials used for recording events were bricks, tiles, shells, and tablets of stone. The modes of writing on these different substances were various. The tiles and brick were impressed with a stamp when in a soft state; the shells and tablets of stone were etched or graven, the figures or characters being cut in their surface, and in some cases also stained with various colors. It was by the ancient art of stamping that the walls, palaces, and towers of Babylon were covered with hiero-

ABCDEFGHIJKLMNOPQRSTUVWXYZ&

abcdefghijklmnopqrstuvwxyz

1 2 3 4 5 6 7 8 9 0

, . : ; ! ? (|) * ' - . . . fi ff ffi ffl lb @ £ \$ []

1/8 1/4 3/8 1/2 5/8 3/4 7/8

True set table characters. Figures and en quad .063; em quad .126; comma, period, and quotations .0315. These sizes will be sent unless otherwise ordered.

Alignment. This face aligns with all 10-point one- and two-letter faces except German.

Will run in all machines.

To avoid errors read notice on page six

MERGENTHALER LINOTYPE CO.

9-POINT NO. 13 (NEW ALIGNMENT)
[ONE-LETTER]

Lower case alphabet 13.36 ems

THE MOST ancient materials employed for recording events were bricks, tiles, shells, and tables of stone. The modes of writing on these different substances were various. The tiles and brick were impressed with a stamp when in a soft state; the shells and tablets of stone were etched or graven, the figures or characters being cut in their surface, and in some cases also stained with various colors. It was by the ancient art of stamping that the walls, palaces, and towers of Babylon were covered with hieroglyphics, which have but recently been brought to light from under the immense mounds of Mesopotamia by Layard and other explorers. The patriarch Job, who is supposed to have

THE MOST ancient materials used for recording events were bricks, tiles, shells, and tablets of stone. The modes of writing on these different substances were various. The tiles and brick were impressed with a stamp when in a soft state; the shells and tablets of stone were etched or graven, the figures or characters being cut in their surface, and in some cases also stained with various colors. It was by the ancient art of stamping that the walls, palaces, and towers of Babylon were covered with hiero-

ABCDEFGHIJKLMNOPQRSTUVWXYZ&

abcdefghijklmnopqrstuvwxyz

1 2 3 4 5 6 7 8 9 0

, . : ; ! ? (|) * ' - — . . fi ff ffi ffl ð @ £ \$ []

1/8 1/4 3/8 1/2 5/8 3/4 7/8

True set table characters. Figures and en quad .063; em quad .126; comma, period, and quotations .0315. These sizes will be sent unless otherwise ordered.

Alignment. This face aligns with all 9-point one- and two-letter faces except German.

Will run in all machines

To avoid errors read notice on page six

MERGENTHALER LINOTYPE CO.

10-POINT NO. 13
[ONE-LETTER]

Lower case alphabet 12.46 ems

THE MOST ancient materials used for recording events were bricks, tiles, shells, and tables of stone. The modes of writing on these different substances were various. The tiles and brick were impressed with a stamp when in a soft state; the shells and tablets of stone were etched or graven, the figures or characters being cut in their surface, and in some cases also stained with various colors. It was by the ancient art of stamping that the walls, palaces, and towers of Babylon were covered with hieroglyphics, which have but recently been brought to light

THE MOST ancient materials used for recording events were bricks, tiles, shells, and tables of stone. The modes of writing on these different substances were various. The tiles and brick were impressed with a stamp when in a soft state; the shells and tablets of stone were etched or graven, the figures or characters being cut in their surface, and in some cases also stained with various colors. It was by the ancient art of stamp-

ABCDEFGHIJKLMN OPQRSTUVWXYZ&
abcdefghijklmnopqrstu vwxyz

1 2 3 4 5 6 7 8 9 0

, . : ; ! ? (|) * ' - — . . . fi fl ff ffi ffl fb @ £ \$ []
1/8 1/4 3/8 1/2 5/8 3/4 7/8

True set table characters. Figures and en quad .070; em quad .140; comma, period, and quotations .035. These sizes will be sent unless otherwise ordered.

Substitute table characters for use with this face can be had as follows: 10-point No. 1.—Figures and en quad .070; em quad .140; comma, period, and quotations .035. 10-point Clarendon No. 1.—Figures and en quad .070; em quad .140; comma, period, and quotations .035.

Alignment. This face aligns with all 10-point one- and two-letter faces except German.

Will run in all machines.

To avoid errors read notice on page six

MERGENTHALER LINOTYPE CO.

5-POINT NO. 18

[ONE-LETTER]

Lower case alphabet 16.19 ems

The most ancient materials employed for recording events were bricks, tiles, shells, and tables of stone. The modes of writing on these different substances were various. The tiles and brick were impressed with a stamp when in a soft state; the shells and tablets of stone were etched or graven, the figures or characters being cut in their surface, and in some cases also stained with various colors. It was by the ancient art of stamping that the walls and palaces of Babylon were covered with hieroglyphics, which have but recently been brought to light from under the immense mounds of Mesopotamia by Layard and other explorers. The patriarch Job, who is supposed to have lived about 2,300 years after the creation, exclaimed, "O that my words were now written! O that they were printed in a book! that they were graven with an iron pen and hid in the rock forever!" Stung with the unjust accusation of his friends, he desires to record his words that the generations following might see the justice of his cause. The English translation has given the allusion to printing to the text, the original word signifying rather to engrave on a plate, which was doubtless the only printing known to Job. Montfaucon purchased at Rome in 1699 an ancient book entirely composed of lead. It was about four inches long and

The most ancient materials employed for recording events were bricks, tiles, shells, and tables of stone. The modes of writing on these different substances were various. The tiles and brick were impressed with a stamp when in a soft state; the shells and tablets of stone were etched or graven, the figures or characters being cut in their surfaces, and in some cases also stained with various colors. It was by the ancient art of stamping that the walls of Babylon were covered with hieroglyphics, which have but recently been brought to light from under the immense mounds of Mesopotamia by Layard and other explorers. The patriarch Job, who is said to have lived about 2,300 years after the creation, exclaimed, "O that my words were now written! O that they were printed in a book! that they were graven with an iron pen and hid in the rock forever!" Stung with the unjust accusations of his friends, he desires to record his words so that the coming generations might see the justice of his cause. The English version has given the allusion to printing to the text, the original word signifying rather to engrave on a plate, which was doubtless the only printing known to Job. Montfaucon purchased at Rome in 1699 an

ABCDEFGHIJKLMNOPQRSTUVWXYZ&

abcdefghijklmnopqrstuvwxyz

1 2 3 4 5 6 7 8 9 0

. : ; ! ? () ' ' * - . . . n n n n n n n n @ £ \$ []

½ ¼ ⅓ ⅔ ⅕ ⅖ ⅗ ⅘

True set table characters. Figures and en quad .035; em quad .070; comma, period, and quotations .028. These sizes will be sent unless otherwise ordered.

Alignment. This face aligns with all 5-point one- and two-letter faces except German.

Will run in all machines.

To avoid errors read notice on page six

MERGENTHALER LINOTYPE CO.

8-POINT NO. 19 [ONE-LETTER]

Lower case alphabet 13.67 ems

THE MOST ancient materials employed for recording events were bricks, tiles, shells, and tables of stone. The modes of writing on these different substances were various. The tiles and brick were impressed with a stamp when in a soft state; the shells and tablets of stone were etched or graven, the figures or characters being cut in their surface, and in some cases also stained with various colors. It was by the ancient art of stamping that the walls, palaces, and towers of Babylon were covered with hieroglyphics, which have but recently been brought to light from under the immense mounds of Mesopotamia by Layard and other explorers. The patriarch Job, who is supposed to have lived about 2,300 years after the creation, exclaimed, "O that my words were now written! O that they were printed in a book!

THE MOST ancient materials employed for recording events were bricks, tiles, shells, and tables of stone. The modes of writing on these different substances were various. The tiles and brick were impressed with a stamp when in a soft state; the shells and tablets of stone were etched or graven, the figures or characters being cut in their surface and in some cases also stained with various colors. It was by the ancient art of stamping that the walls, palaces, and towers of Babylon were covered with hieroglyphics, which have but recently been brought to light from under the immense mounds of Meso-

ABCDEFGHIJKLMNOPQRSTUVWXYZ&

abcdefghijklmnopqrstuvwxyz

1 2 3 4 5 6 7 8 9 0

, . : ; ! ? (|) * ' ' - . . . fi fl ff ffi ffl lb @ £ \$ []

1/8 1/4 3/8 1/2 5/8 3/4 7/8

True set table characters. Figures and en quad .056; em quad .112; comma, period, and quotations .028. These sizes will be sent unless otherwise ordered.

Substitute table characters for use with this face can be had as follows: 8-point No. 1.—Figures and figure space .059; double figure space .118; comma, period, and quotations .031. 8-point Clarendon No. 1.—Figures and figure space .059; double figure space .118; comma, period, and quotations .0295.

Alignment. This face aligns with all 8-point one- and two-letter faces having high alignment except German.

Will run in all machines.

To avoid errors read notice on page six

MERGENTHALER LINOTYPE CO.

7-POINT NO. 21

[ONE-LETTER]

Lower case alphabet 14.73 ems

THE MOST ancient materials employed for recording events were bricks, tiles, shells, and tables of stone. The modes of writing on these different substances were various. The tiles and brick were impressed with a stamp when in a soft state; the shells and tablets of stone were etched or graven, the figures or characters being cut in their surface, and in some cases also stained with various colors. It was by the ancient art of stamping that the walls, palaces, and towers of Babylon were covered with hieroglyphics, which have but recently been brought to light from under the immense mounds of Mesopotamia by Layard and other explorers. The patriarch Job, who is supposed to have lived about 2,300 years after the creation, exclaimed, "O that my words were now written! O that they were printed in a book! that

THE MOST ancient materials employed for recording events were bricks, tiles, shells, and tables of stone. The modes of writing on these different substances were various. The tiles and brick were impressed with a stamp when in a soft state; the shells and tablets of stone were etched or graven, the figures or characters being cut in their surface, and in some cases also stained with various colors. It was by the ancient art of stamping that the walls, palaces, and towers of Babylon were covered with hieroglyphics, which have but recently been brought to light from under the immense mounds of Mesopotamia by Layard and other explorers. The patriarch Job, who is supposed to have lived about 2,300 years

ABCDEFGHIJKLMN OPQRSTUVWXYZ&

abcdefghijklmnopqrstuvwxy z

1 2 3 4 5 6 7 8 9 0

, . : ; ! ? () * ' ' - _ : ñ ñ ñ ñ ñ ñ ñ @ £ \$ []

¼ ½ ¾ ¼ ½ ¾ ¼ ½ ¾

True set table characters. Figures and en quad .049; em quad .098; comma, period, and quotations .031. These sizes will be sent unless otherwise ordered.

Substitute table characters for use with this face can be had as follows: 7-point No. 1.—Figures and figure space .059; double figure space .118; comma, period, and quotations .031.

Alignment. This face aligns with all 7-point one- and two-letter faces except German.

Will run in all machines.

To avoid errors read notice on page six

MERGENTHALER LINOTYPE CO.

8-POINT CHELTENHAM [ONE-LETTER]

Lower case alphabet 11.73 ems

The most ancient materials used for recording events were bricks, tiles, shells, and tables of stone. The modes of writing on these different substances were various. The tiles and brick were impressed with a stamp when in a soft state; the shells and tablets of stone were etched or graven, the figures or characters being cut in their surface, and in some cases stained with various colors. It was by the ancient art of stamping that the walls, palaces, and towers of Babylon were covered with hieroglyphics, which have but recently been brought to light from under the immense mounds of Mesopotamia by Layard and other explorers. The patriarch Job, who is supposed to have lived about 2,300 years after the creation, exclaimed, "O that my words were now written! O that they were printed in a book! that they were graven with an iron pen, and hid in the rock forever!" Stung with the unjust accusation of his friends, he desires to record his words that the generations following

The most ancient materials used for recording events were bricks, tiles, shells, and tables of stone. The modes of writing on these different substances were various. The tiles and brick were impressed with a stamp when in a soft state; the shells and tablets of stone were etched or graven, the figures being cut in their surface, and in some cases also stained with various colors. It was by the ancient art of stamping that the walls, palaces, and towers of Babylon were covered with hieroglyphics, which have but recently been brought to light from under the immense mounds of Mesopotamia by Layard and other explorers. The patriarch Job, who is supposed to have lived about 2,300 years after the creation, exclaimed, "O that my words were now written! O that

ABCDEFGHIJKLMNOPQRSTUVWXYZ&

abcdefghijklmnopqrstuvwxyz

1 2 3 4 5 6 7 8 9 0

. . . ; ! ? (|) - * ' ' - — . . . fi ff ff ff lb @ £ \$ []

1/8 1/4 3/8 1/2 5/8 3/4 7/8

True set table characters. Figures and en quad .056; em quad .112; comma, period and quotations .028. These sizes will be sent unless otherwise ordered.

Alignment. This face aligns with all 8-point one- and two-letter faces having low alignment except German.

Will run in all machines.

To avoid errors read notice on page six

MERGENTHALER LINOTYPE CO.

10-POINT CHELTENHAM [ONE-LETTER]

Lower case alphabet 11.16 ems

The most ancient materials used for recording events were bricks, tiles, shells, and tables of stone. The modes of writing on these different substances were various. The tiles and brick were impressed with a stamp when in a soft state; the shells, and tablets of stone were etched or graven, the figures or characters being cut in their surface, and in some cases also stained with various colors. It was by the ancient art of stamping that the walls, palaces, and towers of Babylon were covered with hieroglyphics, which have but recently been brought to light from under the immense mounds of Mesopotamia by Layard and other explorers. The patriarch Job, who is supposed to

The most ancient materials used for recording events were bricks, tiles, shells, and tables of stone. The modes of writing on these different substances were various. The tiles and brick were impressed with a stamp when in a soft state; the shells and tablets of stone were etched or graven, the figures or characters being cut in their surface, and in some cases also stained with various colors. It was by the ancient art of stamping that the walls, palaces, and towers of Babylon were covered with hieroglyph-

ABCDEFGHIJKLMNOPQRSTUVWXYZ&

abcdefghijklmnopqrstuvwxyz

1 2 3 4 5 6 7 8 9 0

, . : ; ! ? () * ' - _ . . . fi ff ffi ffl lb @ £ \$ []

1/8 1/4 3/8 1/2 5/8 3/4 7/8

Special set table characters. Figures and figure space .077; double figure space .154; comma, period, and quotations .0385. These sizes will be sent unless otherwise ordered.

Alignment. This face aligns with all 10-point one- and two-letter faces except German.

Will run in all machines.

To avoid errors read notice on page six

SPECIMENS OF LINOTYPE FACES

**10-POINT
CHELTENHAM
One-Letter**

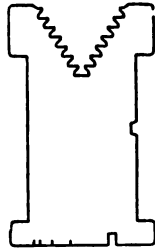

**SPECIAL
CHARACTERS**

Small Caps.

ABCDEFGHIJKLMN**OP**QRSTU**VW**XYZ&

Low Cap Accents—Regular mold may be used.

À Á Ç È É Ê Ë Ì Í Ö Ù Ú Û Ü

Small Cap Accents.

É

á à â ã ç è é ê ë ì í î ï ñ ó ò ô õ ú û ü

Æ Æ æ Œ Œ œ Qu ç st / - " § ¶ || † ‡

1/3 2/3 1/5 2/5 3/5 4/5 1/6 5/6 1/8 1/4 3/8 1/2 5/8 3/4 7/8 1/3 2/3 3/4 4/5 5/6

□ □ abcdefghijklmnopqrstuvwxyz abcdefghijklmnopqrstuvwxyz □ □

□ □ abcdefghijklmnopqrstuvwxyz abcdefghijklmnopqrstuvwxyz □ □ □

1234567890 +- x () ' " h m s ! " ' ° a c o [] / + - x () [] - . 1234567890

Piece Fractions—Upper half: 1234567890 Lower half: 1/2 1/3 1/4 1/5 1/6 1/8 1/10 1/12 1/16 1/20 1/24 1/30 1/40 1/48 1/60 1/80 1/96 1/120 1/144 1/180 1/240 1/360 1/480 1/720 1/960 1/1440 1/2880 1/4320 1/5760 1/7200 1/8640 1/11520 1/15360 1/20480 1/27648 1/36864 1/49152 1/64512 1/85984 1/114304 1/152400 1/203200 1/270720 1/357120 1/476160 1/631680 1/842240 1/1122960 1/1497280 1/1996480 1/2661920 1/3549120 1/4732160 1/6310400 1/8414080 1/11218880 1/14959360 1/19945600 1/26627200 1/35472000 1/47344000 1/63136000 1/84182400 1/112256000 1/149696000 1/199616000 1/266432000 1/354880000 1/473760000 1/631712000 1/842272000 1/1123008000 1/1497536000 1/1997120000 1/2665760000 1/3549440000 1/4739200000 1/6321760000 1/8426880000 1/11235840000 1/14981120000 1/19977440000 1/26663840000 1/35500800000 1/47408000000 1/63264000000 1/84315200000 1/112414400000 1/149872000000 1/199836800000 1/266702400000 1/355104000000 1/474240000000 1/633104000000 1/843616000000 1/1124704000000 1/1499312000000 1/1998992000000 1/2667648000000 1/3551680000000 1/4744000000000 1/6335680000000 1/8440800000000 1/11252640000000 1/14998720000000 1/19996160000000 1/26682720000000 1/35523200000000 1/47456000000000 1/63403200000000 1/84454400000000 1/112582400000000 1/150041600000000 1/199924000000000 1/266889600000000 1/355296000000000 1/474720000000000 1/634496000000000 1/845008000000000 1/1126384000000000 1/1500960000000000 1/1999864000000000 1/2669520000000000 1/3553600000000000 1/4748800000000000 1/6349600000000000 1/8454720000000000 1/11269440000000000 1/15015040000000000 1/19994880000000000 1/26701440000000000 1/35542400000000000 1/47504000000000000 1/63542400000000000 1/84593600000000000 1/112750400000000000 1/150204800000000000 1/199951200000000000 1/267076800000000000 1/355488000000000000 1/475200000000000000 1/635888000000000000 1/846400000000000000 1/1128064000000000000 1/1502592000000000000 1/1999536000000000000 1/2671392000000000000 1/3555520000000000000 1/4753600000000000000 1/6363520000000000000 1/8468640000000000000 1/11286240000000000000 1/15031360000000000000 1/19995600000000000000 1/26720160000000000000 1/35561600000000000000 1/47552000000000000000 1/63681600000000000000 1/84732800000000000000 1/112918400000000000000 1/150368000000000000000 1/199958400000000000000 1/267264000000000000000 1/355680000000000000000 1/475680000000000000000 1/637280000000000000000 1/847792000000000000000 1/1129744000000000000000 1/1504224000000000000000 1/1999608000000000000000 1/2673264000000000000000 1/3557440000000000000000 1/4758400000000000000000 1/6377440000000000000000 1/8482560000000000000000 1/11303040000000000000000 1/15047680000000000000000 1/19996320000000000000000 1/26738880000000000000000 1/35580800000000000000000 1/47600000000000000000000 1/63820800000000000000000 1/84872000000000000000000 1/113086400000000000000000 1/150531200000000000000000 1/199965600000000000000000 1/267451200000000000000000 1/355872000000000000000000 1/476160000000000000000000 1/638672000000000000000000 1/849184000000000000000000 1/1131424000000000000000000 1/1505856000000000000000000 1/1999680000000000000000000 1/2675136000000000000000000 1/3559360000000000000000000 1/4763200000000000000000000 1/6391360000000000000000000 1/8496480000000000000000000 1/11319840000000000000000000 1/15064000000000000000000000 1/19997040000000000000000000 1/26757600000000000000000000 1/356000000000000000000000000 1/47648000000000000000000000 1/63960000000000000000000000 1/85011200000000000000000000 1/113254400000000000000000000 1/150694400000000000000000000 1/199972800000000000000000000 1/267638400000000000000000000 1/356064000000000000000000000 1/476640000000000000000000000 1/640064000000000000000000000 1/850624000000000000000000000 1/1133104000000000000000000000 1/1507488000000000000000000000 1/1999752000000000000000000000 1/2677008000000000000000000000 1/3561280000000000000000000000 1/4768000000000000000000000000 1/6405280000000000000000000000 1/8511360000000000000000000000 1/11336640000000000000000000000 1/15080320000000000000000000000 1/19997760000000000000000000000 1/26776320000000000000000000000 1/35619200000000000000000000000 1/47696000000000000000000000000 1/64099200000000000000000000000 1/85164800000000000000000000000 1/113422400000000000000000000000 1/150857600000000000000000000000 1/199980000000000000000000000000 1/267825600000000000000000000000 1/356256000000000000000000000000 1/477120000000000000000000000000 1/641456000000000000000000000000 1/852160000000000000000000000000 1/1134784000000000000000000000000 1/1509120000000000000000000000000 1/1999824000000000000000000000000 1/2678880000000000000000000000000 1/3563200000000000000000000000000 1/4772800000000000000000000000000 1/6419200000000000000000000000000 1/8526720000000000000000000000000 1/11353440000000000000000000000000 1/15096640000000000000000000000000 1/19998480000000000000000000000000 1/26795040000000000000000000000000 1/35638400000000000000000000000000 1/47744000000000000000000000000000 1/64238400000000000000000000000000 1/85318400000000000000000000000000 1/113590400000000000000000000000000 1/151020800000000000000000000000000 1/199987200000000000000000000000000 1/268012800000000000000000000000000 1/356448000000000000000000000000000 1/477600000000000000000000000000000 1/642848000000000000000000000000000 1/853696000000000000000000000000000 1/1136464000000000000000000000000000 1/1510752000000000000000000000000000 1/1999896000000000000000000000000000 1/2680752000000000000000000000000000 1/3565120000000000000000000000000000 1/4777600000000000000000000000000000 1/6433120000000000000000000000000000 1/8542080000000000000000000000000000 1/11370240000000000000000000000000000 1/15112960000000000000000000000000000 1/19999200000000000000000000000000000 1/26813760000000000000000000000000000 1/35657600000000000000000000000000000 1/47792000000000000000000000000000000 1/64377600000000000000000000000000000 1/85472000000000000000000000000000000 1/113758400000000000000000000000000000 1/151184000000000000000000000000000000 1/199994400000000000000000000000000000 1/268200000000000000000000000000000000 1/356640000000000000000000000000000000 1/478080000000000000000000000000000000 1/644240000000000000000000000000000000 1/855232000000000000000000000000000000 1/1138144000000000000000000000000000000 1/1512384000000000000000000000000000000 1/1999968000000000000000000000000000000 1/2682624000000000000000000000000000000 1/3567040000000000000000000000000000000 1/4782400000000000000000000000000000000 1/6447040000000000000000000000000000000 1/8557440000000000000000000000000000000 1/11387040000000000000000000000000000000 1/15129280000000000000000000000000000000 1/19999920000000000000000000000000000000 1/26832480000000000000000000000000000000 1/35676800000000000000000000000000000000 1/47840000000000000000000000000000000000 1/64516800000000000000000000000000000000 1/85625600000000000000000000000000000000 1/113926400000000000000000000000000000000 1/151347200000000000000000000000000000000 1/199991600000000000000000000000000000000 1/268387200000000000000000000000000000000 1/356832000000000000000000000000000000000 1/478560000000000000000000000000000000000 1/645632000000000000000000000000000000000 1/856768000000000000000000000000000000000 1/1139824000000000000000000000000000000000 1/1514016000000000000000000000000000000000 1/1999940000000000000000000000000000000000 1/2684500000000000000000000000000000000000 1/3568960000000000000000000000000000000000 1/4787200000000000000000000000000000000000 1/6460960000000000000000000000000000000000 1/8572800000000000000000000000000000000000 1/11403840000000000000000000000000000000000 1/15145600000000000000000000000000000000000 1/19999640000000000000000000000000000000000 1/26851240000000000000000000000000000000000 1/35696000000000000000000000000000000000000 1/47888000000000000000000000000000000000000 1/64656000000000000000000000000000000000000 1/85779200000000000000000000000000000000000 1/114094400000000000000000000000000000000000 1/151510400000000000000000000000000000000000 1/199998800000000000000000000000000000000000 1/268574800000000000000000000000000000000000 1/357024000000000000000000000000000000000000 1/479040000000000000000000000000000000000000 1/647024000000000000000000000000000000000000 1/858304000000000000000000000000000000000000 1/1141504000000000000000000000000000000000000 1/1515648000000000000000000000000000000000000 1/1999912000000000000000000000000000000000000 1/2686372000000000000000000000000000000000000 1/3570880000000000000000000000000000000000000 1/4792000000000000000000000000000000000000000 1/6474880000000000000000000000000000000000000 1/8588160000000000000000000000000000000000000 1/11420640000000000000000000000000000000000000 1/15161920000000000000000000000000000000000000 1/199993600000000000000000000000000000000000000 1/268699600000000000000000000000000000000000000 1/357152000000000000000000000000000000000000000 1/4793600 1/647952000000000000000000000000000000000000000 1/859328000000000000000000000000000000000000000 1/1142624000000000000000000000000000000000000000 1/1516736000000000000000000000000000000000000000 1/199996000 1/26876200 1/35721600 1/47952000 1/64841600 1/86035200 1/114318400 1/151728000 1/1999984000 1/268824400 1/3572800 1/4796800 1/6488800 1/861376000 1/1143744000 1/1517824000 1/1999908000 1/2688868000 1/35734400 1/47984000 1/64934400 1/86236800 1/114430400 1/1518368000 1/199993200 1/268948800 1/357408000 1/48000 1/649808000 1/86337600 1/114486400 1/151891200 1/199995600 1/269011200 1/357472000 1/4801600 1/650272000 1/86438400 1/114542400 1/151945600 1/199998000 1/269073600 1/357536000 1/4803200 1/650736000 1/8653920000000

MERGENTHALER LINOTYPE CO.

12-POINT CHELTENHAM
[ONE-LETTER]

Lower case alphabet 10.92 ems

The most ancient materials employed for recording events were bricks, tiles, shells, and tables of stone. The modes of writing on these different substances were various. The tiles and brick were impressed with a stamp when in a soft state; the shells and tablets of stone were etched or graven, the figures or characters being cut in their surface, and in some cases also stained with various colors. It was by the ancient art of stamping that the walls, palaces,

The most ancient materials used for recording events were bricks, tiles, shells, and tables of stone. The modes of writing on these different substances were various. The tile and brick were impressed with a stamp when in a soft state; the shells and tablets of stone were etched or graven, the figures or characters being cut in their sur-

ABCDEFGHIJKLMNOPQRSTUVWXYZ&

abcdefghijklmnopqrstuvwxyz

. . . ; ! ? (|) * ' ' - — . . . fi ff ff ff ff lb @ £ \$ []

1 2 3 4 5 6 7 8 9 0

1/8 1/4 3/8 1/2 5/8 3/4 7/8

True set table characters. Figures and en quad .084; em quad .168; comma, period, and quotations .042. These sizes will be sent unless otherwise ordered.

Alignment. This face aligns with all 12-point one- and two-letter faces except German.

Will run in machines Nos. 2, 3, 4 and 5.

To avoid errors read notice on page six

MERGENTHALER LINOTYPE CO.

6-POINT OLD STYLE NO. 1

[ONE-LETTER]

Lower case alphabet 15.64 ems

THE most ancient materials employed for recording events were bricks, tiles, shells, and tables of stone. The modes of writing on these different substances were various. The tiles and brick were impressed with a stamp when in a soft state; the shells and tablets of stone were etched or graven, the figures or characters being cut in their surface and in some cases also stained with various colors. It was by the ancient art of stamping that the walls, palaces, and towers of Babylon were covered with hieroglyphics, which have but recently been brought to light from under the immense mounds of Mesopotamia by Layard and other explorers. The patriarch Job, who is supposed to have lived about 2,300 years after the creation, exclaimed, "O that my words were now written! O that they were printed in a book! that they were graven with an iron pen and hid in the rock forever!" Stung with the unjust accusation of his friends he desires to record his words that the generations following might see the justice of his cause. The English translation has given the allusion

THE most ancient materials used for recording events were bricks, tiles, shells, and tables of stone. The modes of writing on these different substances were various. The tiles and brick were impressed with a stamp when in a soft state; the shells and tablets of stone were etched or graven, the figures or characters being cut in their surface, and in some cases also stained with various colors. It was by the ancient art of stamping that the walls, palaces, and towers of Babylon were covered with hieroglyphics, which have but recently been brought to light from under the immense mounds of Mesopotamia by Layard and other explorers. The patriarch Job, who is supposed to have lived about 2,300 years after the creation, exclaimed, "O that my words were now written! O that they were printed in a book! that they were graven with an iron pen and hid in the rock forever!" Stung with the unjust accusa-

ABCDEFGHIJKLMN OPQRSTUVWXYZ&

abcdefghijklmnopqrstuvwxyz

1 2 3 4 5 6 7 8 9 0

. . . ; ! ? () * ' ' - . . . fi fl ff ffi fb @ £ \$ []

⅓ ¼ ⅕ ⅖ ⅗ ⅘ ⅙

True set table characters. Figures and en quad .042; em quad .084; comma, period, and quotations .028. These sizes will be sent unless otherwise ordered.

Substitute table characters for use with this face can be had as follows: 6-point No. 12.—Figures and en quad .042; em quad .084; comma, period and quotations .031.

Alignment. This face aligns with all 6-point one- and two-letter faces except German.

Will run in all machines.

To avoid errors read notice on page six

MERGENTHALER LINOTYPE CO.

8-POINT OLD STYLE NO. 1

[ONE-LETTER]

Lower case alphabet 14.24 ems

THE MOST ancient materials employed for recording events were bricks, tiles, shells, and tables of stone. The modes of writing on these different substances were various. The tiles and brick were impressed with a stamp when in a soft state; the shells and tablets of stone were etched or graven, the figures or characters being cut in their surface, and in some cases also stained with various colors. It was by the ancient art of stamping that the walls, palaces, and towers of Babylon were covered with hieroglyphics, which have but recently been brought to light from under the immense mounds of Mesopotamia by Layard and other explorers. The patriarch Job, who is supposed to have lived about 2,300 years after the creation, exclaimed, "O that my words were now written! O that they were printed in a book! that they were graven,

THE MOST ancient materials used for recording events were bricks, tiles, shells, and tables of stone. The modes of writing on these different substances were various. The tiles and brick were impressed with a stamp when in a soft state; the shells and tablets of stone were etched or graven, the figures or characters being cut in their surface, and in some cases stained with various colors. It was by the ancient art of stamping that the walls, palaces, and towers of Babylon were covered with hieroglyphics, which have but recently been brought to light from under the immense mounds of Mesopotamia by

ABCDEFGHIJKLMNPOQRSTUVWXYZ&

abcdefghijklmnopqrstuvwxyz

1 2 3 4 5 6 7 8 9 0

, . : ; ! ? (|) * ' ' - — . . . fi fl ff ffi ffl th @ £ \$ []

⅛ ¼ ⅜ ½ ⅝ ¾ ⅞

True set table characters. Figures and en quad .056; em quad .112; comma, period, and quotations .031. These sizes will be sent unless otherwise ordered.

Substitute table characters for use with this face can be had as follows: 8-point Old Style No. 1 Modernized figures.—Figures and en quad .056 em quad .112; comma, period, and quotations .031.

Alignment. This face aligns with all 8-point one- and two-letter faces having low alignment except German.

Will run in all machines.

To avoid errors read notice on page six

MERGENTHALER LINOTYPE CO.

9-POINT OLD STYLE NO. 1 [ONE-LETTER]

Lower case alphabet 13.26 ems

THE MOST ancient materials employed for recording events were bricks, tiles, shells, and tables of stone. The modes of writing on these different substances were various. The tiles and brick were impressed with a stamp when in a soft state; the shells and tablets of stone were etched or graven, the figures or characters being cut in their surface, and in some cases also stained with various colors. It was by the ancient art of stamping that the walls, palaces, and towers of Babylon were covered with hieroglyphics, which have but recently been brought to light from under the immense mounds of Mesopotamia by Layard and other explorers.

THE MOST ancient materials used for recording events were bricks, tiles, shells, and tables of stone. The modes of writing on these different substances were various. The tiles and brick were impressed with a stamp when in a soft state; the shells and tablets of stone were etched or graven, the figures or characters being cut in their surface, and in some cases also stained with various colors. It was by the ancient art of stamping that the walls, palaces, and towers of

ABCDEFGHIJKLMN OPQRSTUVWXYZ &
abcdefghijklmnopqrstuvwxyz

1 2 3 4 5 6 7 8 9 0
, . : ; ! ? () * ' - . . . fi ff ffi ffl lb @ £ \$ []
 $\frac{1}{8}$ $\frac{1}{4}$ $\frac{3}{8}$ $\frac{1}{2}$ $\frac{5}{8}$ $\frac{3}{4}$ $\frac{7}{8}$

True set table characters. Figures and en quad .063; em quad .126; comma, period, and quotations .0315. These sizes will be sent unless otherwise ordered.

Substitute table characters for use with this face can be had as follows: 9-point No. 13 New Alignment one-letter.—Figures and en quad .063; em quad .126; comma, period, and quotations .0315. 9-point Old Style No. 1 Modernized figures.—Figures and en quad .063; em quad .126.

Alignment. This face aligns with all 9-point one- and two-letter faces except German.

Will run in all machines.

To avoid errors read notice on page six

MERGENTHALER LINOTYPE CO.

10-POINT OLD STYLE NO. 1

[ONE-LETTER]

Lower case alphabet 13.04 ems

THE MOST ancient materials employed for recording events were bricks, tiles, shells, and tables of stone. The modes of writing on these different substances were various. The tiles and brick were impressed with a stamp when in a soft state; the shells and tablets of stone were etched or graven, the figures or characters being cut in their surface, and in some cases stained with various colors. It was by the ancient art of stamping that the walls, palaces, and towers of Babylon were covered with hieroglyphics, which have but recently

THE MOST ancient materials used for recording events were bricks, tiles, shells, and tables of stone. The modes of writing on these different substances were various. The tiles and brick were impressed with a stamp when in a soft state; the shells and tablets of stone were etched or graven, the figures or characters being cut in their surface, and in some cases also stained with various colors. It was by the

ABCDEFGHIJKLMNOPQRSTUVWXYZ&

abcdefghijklmnopqrstuvwxyz

1 2 3 4 5 6 7 8 9 0

, . : ; ! ? (|) * ' - . . . fi fl ff ffi ffl lb @ £ \$ []

1/8 1/4 3/8 1/2 5/8 3/4 7/8

True set table characters. Figures and en quad .070; em quad .140; comma, period, and quotations .035. These sizes will be sent unless otherwise ordered.

Substitute table characters for use with this face can be had as follows: 10-point Old Style No. 1 Modernized figures.—Figures and en quad .070; em quad .140; comma, period, and quotations .035. 10-point No. 13 one-letter.—Figures and en quad .070; em quad .140; comma, period, and quotations .035.

Alignment. This face aligns with all 10-point one- and two-letter faces except German.
Will run in all machines.

To avoid errors read notice on page six

MERGENTHALER LINOTYPE CO.

11-POINT OLD STYLE NO. 1

[ONE-LETTER]

Lower case alphabet 12.62 ems

THE MOST ancient materials employed for recording events were bricks, tiles, shells, and tables of stone. The modes of writing on these different substances were various. The tiles and brick were impressed with a stamp when in a soft state; the shells and tablets of stone were etched or graven, the figures or characters being cut in their surface, and in some cases also stained with various colors. It was by the ancient art of stamping that the

THE MOST ancient materials used for recording events were bricks, tiles, shells, and tables of stone. The modes of writing on these different substances were various. The tiles and brick were impressed with a stamp when in a soft state; the shells and tablets of stone were etched or graven, the figures or characters being cut in their surface,

ABCDEFGHIJKLMNOPQRSTUVWXYZ&

abcdefghijklmnopqrstuvwxyz

1 2 3 4 5 6 7 8 9 0

, . : ; ! ? (|) * ' ' - — . . . fi fl ff ffi ffl th @ £ \$ []

1/8 1/4 3/8 1/2 5/8 3/4 7/8

True set table characters. Figures and en quad .077; em quad .154; comma, period, and quotations .0385. These sizes will be sent unless otherwise ordered.

Substitute table characters for use with this face can be had as follows: 11-point Old Style No. 1 Modernized figures.

Alignment. This face aligns with all 11-point one and two-letter faces except German.

Will run in all machines.

To avoid errors read notice on page six

MERGENTHALER LINOTYPE CO.

6-POINT RONALDSON

[ONE-LETTER]

Lower case alphabet 15.64 ems

THE MOST ancient materials employed for recording events were bricks, tiles, shells, and tables of stone. The modes of writing on these different substances were various. The tiles and brick were impressed with a stamp when in a soft state; the shells and tablets of stone were etched or graven, the figures or characters being cut in their surface and in some cases also stained with various colors. It was by the ancient art of stamping that the walls, palaces, and towers of Babylon were covered with hieroglyphics, which have but recently been brought to light from under the immense mounds of Mesopotamia by Layard and other explorers. The patriarch Job, who is supposed to have lived about 2,300 years after the creation, exclaimed, "O that my words were now written! O that they were printed in a book! that they were graven with an iron pen, and hid in the rock forever!" Stung with the unjust accusation of his friends, he desires to record his words that the generations following might see the justice of his cause. The English translation has given the

THE MOST ancient materials used for recording events were bricks, tiles, shells, and tables of stone. The modes of writing on these different substances were various. The tiles and brick were impressed with a stamp when in a soft state; the shells and tablets of stone were etched or graven, the figures or characters being cut in their surface, and in some cases also stained with various colors. It was by the ancient art of stamping that the walls, palaces, and towers of Babylon were covered with hieroglyphics, which have but recently been brought to light from under the immense mounds of Mesopotamia by Layard and other explorers. The patriarch Job, who is supposed to have lived about 2,300 years after the creation, exclaimed, "O that my words were now written! O that they were printed in a book! that they were graven with an iron pen, and hid in the

ABCDEFGHIJKLMNOPQRSTUVWXYZ&
abcdefghijklmnopqrstuvwxyz

1 2 3 4 5 6 7 8 9 0

, . : ; ! (|) * ' ' - . . . fi ff ffi ffb @ £ \$ []
¼ ½ ¾ ⅓ ⅔ ⅖ ⅘

True set table characters. Figures and en quad .042; em quad .084; comma, period, and quotations .028. These sizes will be sent unless otherwise ordered.

Substitute table characters for use with this face can be had as follows: 6-point No. 12.—Figures and en quad .042; em quad .084; comma, period and quotations .031.

Alignment. This face aligns with all 6-point one- and two-letter faces except German.

Will run in all machines.

To avoid errors read notice on page six

MERGENTHALER LINOTYPE CO.

8-POINT RONALDSON

[ONE-LETTER]

Lower case alphabet 14.24 ems

THE MOST ancient materials employed for recording events were bricks, tiles, shells, and tables of stone. The modes of writing on these different substances were various. The tiles and brick were impressed with a stamp when in a soft state; the shells and tablets of stone were etched or graven, the figures or characters being cut in their surface, and in some cases also stained with various colors. It was by the ancient art of stamping that the walls, palaces, and towers of Babylon were covered with hieroglyphics, which have but recently been brought to light from under the immense mounds of Mesopotamia by Layard and other explorers. The patriarch Job, who is supposed to have lived about 2,300 years after the creation, exclaimed, "O that my words were now written! O that they were printed in a book! that they were graven,

THE MOST ancient materials used for recording events were bricks, tiles, shells, and tables of stone. The modes of writing on these different substances were various. The tiles and brick were impressed with a stamp when in a soft state; the shells and tablets of stone were etched or graven, the figures or characters being cut in their surface, and in some cases stained with various colors. It was by the ancient art of stamping that the walls, palaces, and towers of Babylon were covered with hieroglyphics, which have but recently been brought to light from under the immense mounds of Mesopotamia by

ABCDEFGHIJKLMNOPQRSTUVWXYZ&

abcdefghijklmnopqrstuvwxyz

1 2 3 4 5 6 7 8 9 0

, . : ; ! ? (|) * ' ' - . . . fi fl ff ffi ffl lb @ £ \$ [] &

1/8 1/4 3/8 1/2 5/8 3/4 7/8

True set table characters. Figures and en quad .056; em quad .112; comma, period, and quotations .031. These sizes will be sent unless otherwise ordered.

Substitute table characters for use with this face can be had as follows: 8-Point Old Style No. 1 Modernized figures.—Figures and en quad .056 em quad .112; comma, period, and quotations .031.

Alignment. This face aligns with all 8-point one- and two-letter faces having low alignment except German.

Will run in all machines.

To avoid errors read notice on page six

MERGENTHALER LINOTYPE CO.

8-POINT RONALDSON

[ONE-LETTER]

Lower case alphabet 14.24 ems

THE MOST ancient materials employed for recording events were bricks, tiles, shells, and tables of stone. The modes of writing on these different substances were various. The tiles and brick were impressed with a stamp when in a soft state; the shells and tablets of stone were etched or graven, the figures or characters being cut in their surface, and in some cases also stained with various colors. It was by the ancient art of stamping that the walls, palaces, and towers of Babylon were covered with hieroglyphics, which have but recently been brought to light from under the immense mounds of Mesopotamia by Layard and other explorers. The patriarch Job, who is supposed to have lived about 2,300 years after the creation, exclaimed, "O that my words were now written! O that they were printed in a book! that they were graven,

THE MOST ancient materials used for recording events were bricks, tiles, shells, and tables of stone. The modes of writing on these different substances were various. The tiles and brick were impressed with a stamp when in a soft state; the shells and tablets of stone were etched or graven, the figures or characters being cut in their surface, and in some cases stained with various colors. It was by the ancient art of stamping that the walls, palaces, and towers of Babylon were covered with hieroglyphics, which have but recently been brought to light from under the immense mounds of Mesopotamia by

ABCDEFGHIJKLMNOPQRSTUVWXYZ&

abcdefghijklmnopqrstuvwxyz

1 2 3 4 5 6 7 8 9 0

, . : ; ! ? () * ' ' - . . . fi fl ff ffi ffl lb @ £ \$ [] &

1/8 1/4 3/8 1/2 5/8 3/4 7/8

True set table characters. Figures and en quad .056; em quad .112; comma, period, and quotations .031. These sizes will be sent unless otherwise ordered.

Substitute table characters for use with this face can be had as follows: 8-Point Old Style No. 1 Modernized figures.—Figures and en quad .056 em quad .112; comma, period, and quotations .031.

Alignment. This face aligns with all 8-point one- and two-letter faces having low alignment except German.

Will run in all machines.

To avoid errors read notice on page six

MERGENTHALER LINOTYPE CO.

9-POINT RONALDSON

[ONE-LETTER]

Lower case alphabet 13.26 ems

THE MOST ancient materials employed for recording events were bricks, tiles, shells, and tables of stone. The modes of writing on these different substances were various. The tiles and brick were impressed with a stamp when in a soft state; the shells and tablets of stone were etched or graven, the figures or characters being cut in their surface, and in some cases also stained with various colors. It was by the ancient art of stamping that the walls, palaces, and towers of Babylon were covered with hieroglyphics, which have but recently been brought to light from under the immense mounds of Mesopotamia by Layard and other explorers.

THE MOST ancient materials used for recording events were bricks, tiles, shells, and tables of stone. The modes of writing on these different substances were various. The tiles and brick were impressed with a stamp when in a soft state; the shells and tablets of stone were etched or graven, the figures or characters being cut in their surface, and in some cases also stained with various colors. It was by the ancient art of stamping that the walls, palaces, and towers of

ABCDEFGHIJKLMNPOQRSTUVWXYZ&

abcdefghijklmnopqrstuvwxyz

1 2 3 4 5 6 7 8 9 0

. : ; ! ? (|) * - . . . fi ff fl fl fb @ £ \$ & Æ Œ []

1/8 1/4 3/8 1/2 5/8 3/4 7/8

True set table characters. Figures and en quad .063; em quad .126; comma, period, and quotations .0315. These sizes will be sent unless otherwise ordered.

Substitute table characters for use with this face can be had as follows: 9-point No. 13 New Alignment one-letter.—Figures and en quad .063; em quad .126; comma, period, and quotations .0315. 9-point Old Style No. 1 Modernized figures.—Figures and en quad .063; em quad .126.

Alignment. This face aligns with all 9-point one- and two-letter faces except German.

Will run in all machines.

To avoid errors read notice on page six

MERGENTHALER LINOTYPE CO.

10-POINT RONALDSON [ONE-LETTER]

Lower case alphabet 13.04 ems

THE MOST ancient materials employed for recording events were bricks, tiles, shells, and tables of stone. The modes of writing on these different substances were various. The tiles and brick were impressed with a stamp when in a soft state; the shells and tablets of stone were etched or graven, the figures or characters being cut in their surface, and in some cases stained with various colors. It was by the ancient art of stamping that the walls, palaces, and towers of Babylon were covered with hieroglyphics, which have but recently

THE MOST ancient materials used for recording events were bricks, tiles, shells, and tables of stone. The modes of writing on these different substances were various. The tiles and brick were impressed with a stamp when in a soft state; the shells and tablets of stone were etched or graven, the figures or characters being cut in their surface, and in some cases also stained with various colors. It was by the

ABCDEFGHIJKLMNOPQRSTUVWXYZ

abcdefghijklmnopqrstuvwxyz

1 2 3 4 5 6 7 8 9 0

, . : ; ! ? (|) * ' " - — . . . fi ff ffi ffl lb @ £ \$ [] &

1/8 1/4 3/8 1/2 5/8 3/4 7/8

True set table characters. Figures and en quad .070; em quad .140; comma, period, and quotations .035. These sizes will be sent unless otherwise ordered.

Substitute table characters for use with this face can be had as follows: 10-point Old Style No. 1 Modernized figures.—Figures and en quad .070; em quad .140; comma, period, and quotations .035. 10-point No. 13 one-letter.—Figures and en quad .070; em quad .140; comma, period, and quotations .035.

Alignment. This face aligns with all 10-point one- and two-letter faces except German.

Will run in all machines.

To avoid errors read notice on page six

MERGENTHALER LINOTYPE CO.

11-POINT RONALDSON [ONE-LETTER]

Lower case alphabet 12.62 ems

THE MOST ancient materials employed for recording events were bricks, tiles, shells, and tables of stone. The modes of writing on these different substances were various. The tiles and brick were impressed with a stamp when in a soft state; the shells and tablets of stone were etched or graven, the figures or characters being cut in their surface, and in some cases also stained with various colors. It was by the ancient art of stamping that the

THE MOST ancient materials used for recording events were bricks, tiles, shells, and tables of stone. The modes of writing on these different substances were various. The tiles and brick were impressed with a stamp when in a soft state; the shells and tablets of stone were etched or graven, the figures or characters being cut in their surface,

ABCDEFGHIJKLMNOPQRSTUVWXYZ&

abcdefghijklmnopqrstuvwxyz

1 2 3 4 5 6 7 8 9 0

, . : ; ! ? (|) * ' - — . . . fi fl ff ffi ffl th @ £ \$ []

1/8 1/4 3/8 1/2 5/8 3/4 7/8

True set table characters. Figures and en quad .077; em quad .154; comma, period, and quotations .0385. These sizes will be sent unless otherwise ordered.

Substitute table characters for use with this face can be had as follows: 11-point Old Style No. 1 Modernized figures.

Alignment. This face aligns with all 11-point one and two-letter faces except German.

Will run in all machines.

To avoid errors read notice on page six

MERGENTHALER LINOTYPE CO.

8-POINT ELZEVIR NO. 1

[ONE-LETTER]

Lower case alphabet 13.34 ems

THE MOST ancient materials used for recording events were bricks, tiles, shells, and tables of stone. The modes of writing on these different substances were various. The tiles and brick were impressed with a stamp when in a soft state; the shells and tablets of stone were etched or graven, the figures or characters being cut in their surface, and in some cases also stained with various colors. It was by the ancient art of stamping that the walls, palaces, and towers of Babylon were covered with hieroglyphics, which have but recently been brought to light from under the immense mounds of Mesopotamia by Layard and other explorers. The patriarch Job, who is supposed to have lived about 2,300 years after the creation, exclaimed, "O that my words were now written! O that they were printed in a book! that they were graven with an iron pen and hid in the rock forever!" Stung with the

THE MOST ancient materials employed for recording events were bricks, tiles, shells, and tables of stone. The modes of writing on these different substances were various. The tiles and brick were impressed with a stamp when in a soft state; the shells and tablets of stone were etched or graven, the figures or characters being cut in their surface, and in some cases also stained with various colors. It was by the ancient art of stamping that the walls, palaces, and towers of Babylon were covered with hieroglyphics, which have but recently been brought to light from under the immense mounds of Mesopotamia by Layard and other explorers. The patriarch Job, who is supposed to have lived about 2,300 years

ABCDEFGHIJKLMNOPQRSTUVWXYZ&

abcdefghijklmnopqrstuvwxyz

1 2 3 4 5 6 7 8 9 0

, . : ; ! ? (|) * ' - _ . . . fi fl ff ffi ffl lb @ £ \$ []

$\frac{1}{8}$ $\frac{1}{4}$ $\frac{3}{8}$ $\frac{1}{2}$ $\frac{5}{8}$ $\frac{3}{4}$ $\frac{7}{8}$

True set table characters. Figures and en quad .056; em quad .112; comma, period, and quotations .028. These sizes will be sent unless otherwise ordered.

Alignment. This face aligns with all 8-point one- and two-letter faces having low alignment except German.

Will run in all machines.

To avoid errors read notice on page six

MERGENTHALER LINOTYPE CO.

10-POINT ELZEVIE NO.1

[ONE-LETTER]

Lower case alphabet 12.11 ems

THE MOST ancient materials used for recording events were bricks, tiles, shells, and tables of stone. The modes of writing on these different substances were various. The tiles and brick were impressed with a stamp when in a soft state; the shells and tablets of stone were etched or graven, the figures or characters being cut in their surface, and in some cases also stained with various colors. It was by the ancient art of stamping that the walls, palaces, and towers of Babylon were covered with hieroglyphics, which have but recently been brought to light from under the immense mounds of Mesopotamia by Layard and other

THE MOST ancient materials used for recording events were bricks, tiles, shells, and tables of stone. The modes of writing on these different substances were various. The tiles and brick were impressed with a stamp when in a soft state; the shells and tablets of stone were etched or graven, the figures or characters being cut in their surface and in some cases also stained with various colors. It was by the ancient art of stamping

ABCDEFGHIJKLMNOPQRSTUVWXYZ&

abcdefghijklmnopqrstuvwxyz

1 2 3 4 5 6 7 8 9 0

, . : ; ! ? () * ' ' . . . fi fl ff ffi ffl lb @ £ \$ []

1/8 1/4 3/8 1/2 5/8 3/4 7/8

True set table characters. Figures and en quad .070; em quad .140; comma, period, and quotations .035. These sizes will be sent unless otherwise ordered.

Alignment. This face aligns with all 10-point one- and two-letter faces except German.

Will run in all machines.

To avoid errors read notice on page six

MERGENTHALER LINOTYPE CO.

12-POINT ELZEVIR NO. 1
[ONE-LETTER]

Lower case alphabet 11.96 ems

THE MOST ancient materials employed for recording events were bricks, tiles, shells, and tables of stone. The modes of writing on these different substances were various. The tiles and brick were impressed with a stamp when in a soft state; the shells and tablets of stone were etched or graven, the figures or characters being cut in their surface, and in some cases stained with various colors. It was by the ancient art of stamping that

THE MOST ancient materials employed for recording events were bricks, tiles, shells, and tables of stone. The modes of writing on these different substances were various. The tiles and brick were impressed with a stamp when in a soft state; the shells and tablets of stone were etched or graven, the fig-

ABCDEFGHIJKLMNOPQRSTUVWXYZ&
abcdefghijklmnopqrstuvwxyz

1 2 3 4 5 6 7 8 9 0

, . : ; ! ? (|) * ' ' - — . . . fi fl ff ffi ffl

fb @ £ \$ [] 1/8 1/4 3/8 1/2 5/8 3/4 7/8

True set table characters. Figures and en quad .084; em quad .168; comma, period, and quotations .042. These sizes will be sent unless otherwise ordered.

Alignment. This face aligns with all 12-point one- and two-letter faces except German.

Will run in all machines.

To avoid errors read notice on page six

MERGENTHALER LINOTYPE CO.

6-POINT GERMAN NO. 1 [ONE-LETTER]

Lower case alphabet 18.48 ems

So wenig für mein treues Volk als für Deutsche bedarf es einer Rechenschaft über die Ursachen des Kriegs, welcher jetzt beginnt: klar liegen sie dem unverbündeten Europa vor Augen. Wir erlagen unter der Uebermacht Frankreichs. Der Friede, der die Hälfte meiner Unterthanen mir entriß, gab uns seine Segnungen nicht, denn er schlug uns tiefere Wunden als selbst der Krieg. Das Mark des Landes ward ausgelogen. Die Hauptfestungen blieben vom Feinde besetzt, der Ackerbau ward gelähmt, sowie der sonst so hochgebrachte Kunstfleiß unserer Städte. Die Freiheit des Handels ward gehemmt und dadurch die Quelle des Erwerbes und des Wohlstandes verstopft. Das Land ward ein Raub der Verarmung. Durch die strengste Erfüllung eingegangener Verbindlichkeiten hoffte ich meinem Volke Erleichterung zu verschaffen, und den französischen Kaiser endlich zu überzeugen, daß es sein eigener Vortheil sei, Preußen seine Unabhängigkeit zu lassen. Aber meine reinsten Absichten wurden durch Uebermuth

So wenig für mein treues Volk als für Deutsche bedarf es einer Rechenschaft über die Ursachen des Kriegs, welcher jetzt beginnt: klar liegen sie dem unverbündeten Europa vor Augen. Wir erlagen unter der Uebermacht Frankreichs. Der Friede, der die Hälfte meiner Unterthanen mir entriß, gab uns seine Segnungen nicht, denn er schlug uns tiefere Wunden als selbst der Krieg. Das Mark des Landes ward ausgelogen. Die Hauptfestungen blieben vom Feinde besetzt, der Ackerbau ward gelähmt, sowie der sonst so hochgebrachte Kunstfleiß unserer Städte. Die Freiheit des Handels ward gehemmt und dadurch die Quelle des Erwerbes und des Wohlstandes verstopft. Das Land ward ein Raub der Verarmung. Durch die strengste Erfüllung eingegangener Verbindlichkeiten hoffte ich meinem Volke Erleichterung zu verschaffen, und den französischen Kaiser endlich zu überzeugen, daß es sein eigener Vortheil sei, Preußen seine Unabhängigkeit zu lassen. Aber meine reinsten Absichten wurden durch Uebermuth und Treulosigkeit

ABCDEFGHIJKLMNOPQRSTUVWXYZ

abcdefghijklmnopqrstuvwxyz

1 2 3 4 5 6 7 8 9 0

. : ; ! ? () , * ' - ¢ ¢ ¢ ¢ ¢ []

¼ ½ ¾ ¼ ¾ ¾

ä ö ü

¢ ¢ ¢ ¢ ¢ ¢ ¢

True set table characters. Figures and en quad .042; em quad .084; comma and period .031. These sizes will be sent unless otherwise ordered.

Alignment. This face aligns with all 6-point German one- and two-letter faces.

Will run in all machines.

To avoid errors read notice on page six

MERGENTHALER LINOTYPE CO.

10-POINT GOTHIC CONDENSED NO. 1.

[ONE-LETTER]

Lower case alphabet 12.08 ems

The most ancient materials employed for recording events were bricks, tiles, shells, and tables of stone. The modes of writing on these different substances were various. The tiles and brick were impressed with a stamp when in a soft state; the shells and tablets of stone were etched or graven, the figures or characters being cut in their surface, and in some cases also stained with various colors. It was by the ancient art of stamping that the walls, palaces, and towers of Babylon were covered with hieroglyphics, which have but recently been brought to

The most ancient materials employed for recording events were bricks, tiles, shells, and tables of stone. The modes of writing on these different substances were various. The tiles and brick were impressed with a stamp when in a soft state; the shells and tablets of stone were etched or graven, the figures or characters being cut in their surface, and in some cases also stained with various colors. It was by the ancient

ABCDEFGHIJKLMNOPQRSTUVWXYZ&

abcdefghijklmnopqrstuvwxy

1 2 3 4 5 6 7 8 9 0

, . : ; ? (|) * ' ' - - - - . . . fi fl ff fm fn @ £ \$ []

$\frac{1}{8}$ $\frac{1}{4}$ $\frac{3}{8}$ $\frac{1}{2}$ $\frac{5}{8}$ $\frac{3}{4}$ $\frac{7}{8}$

Special set table characters. Figures and figure space .083; double figure space .166; comma, period, and quotations .0415. Unit system, $\frac{1}{4}$ -point basis.

Alignment. This face aligns with all 10-point faces except German. Will run in all machines.

To avoid errors read notice on page six

MERGENTHALER LINOTYPE CO.

8-POINT GERMAN NO. 1 [ONE-LETTER]

Lower case alphabet 12.21 ems

So wenig für mein treues Volk als für Deutsche bedarf es einer Rechenschaft über die Ursachen des Kriegs, welcher jetzt beginnt: klar liegen sie dem unverblendeten Europa vor Augen. Wir erlagen unter der Uebermacht Frankreichs. Der Friede, der die Hälfte meiner Unterthanen mir entriß, gab uns seine Segnungen nicht, denn er schlug uns tiefere Wunden als selbst der Krieg. Das Mark des Landes ward ausgefogen. Die Hauptfestungen blieben vom Feinde besetzt, der Ackerbau ward gelähmt, sowie der sonst so hochgebrachte Kunstfleiß unserer Städte. Die Freiheit des Handels ward gehemmt, und dadurch die Quelle des Erwerbes und des Wohlstandes verstopft. Das Land ward ein Raub der Verarmung. Durch die strengste Erfüllung

So wenig für mein treues Volk als für Deutsche bedarf es einer Rechenschaft über die Ursachen des Kriegs, welcher jetzt beginnt: klar liegen sie dem unverblendeten Europa vor Augen. Wir erlagen unter der Uebermacht Frankreichs. Der Friede, der die Hälfte meiner Unterthanen mir entriß, gab uns seine Segnungen nicht, denn er schlug uns tiefere Wunden als selbst der Krieg. Das Mark des Landes ward ausgefogen. Die Hauptfestungen blieben vom Feinde besetzt, der Ackerbau ward gelähmt, sowie der sonst so hochgebrachte Kunstfleiß unserer Städte. Die Freiheit des Handels ward gehemmt, und dadurch die Quelle des Erwerbes und des Wohlstandes verstopft. Der

ABCDEFGHIJKLMNOPQRSTUVWXYZ&

abcdefghijklmnopqrstuvwxyz

1 2 3 4 5 6 7 8 9 0

, . : ; ! ? () " ' * ' : — fi fl ff B \$ []

1/8 1/4 3/8 1/2 5/8 3/4 7/8

ä ö ü

fi fl ff ff ff ff ff

True set table characters. Figures and en quad .056; em quad .112; comma and period .031. These sizes will be sent unless otherwise ordered.

Alignment. This face aligns with all 8-point German one- and two-letter faces.

Will run in all machines.

To avoid errors read notice on page six

MERGENTHALER LINOTYPE CO.

9-POINT GERMAN NO. 2

[ONE-LETTER]

Lower case alphabet 11.44 ems

So wenig für mein treues Volk als für Deutsche bedarf es einer Rechenschaft über die Ursachen des Kriegs, welcher jetzt beginnt: klar liegen sie dem unverbundenen Europa vor Augen. Wir erlagen unter der Uebermacht Frankreichs. Der Friede, der die Hälfte meiner unterthanen mir entriß, gab uns seine Segnungen nicht, denn er schlug uns tiefere Wunden, als selbst der Krieg. Das Mark des Landes ward ausgefogen. Die Hauptfestungen blieben vom Feinde besetzt, der Ackerbau ward gelähmt, sowie der sonst so hochgebrachte Kunstfleiß unserer Städte. Die Freiheit des Handels ward gehemmt, und dadurch die Quelle des Erwerbes und des Wohlstandes verstopft. Das Land ward ein Raub der Berarmung. Durch die strengste Erfüllung eingegangener

So wenig für mein treues Volk als für Deutsche bedarf es einer Rechenschaft über die Ursachen des Kriegs, welcher jetzt beginnt: klar liegen sie dem unverbundenen Europa vor Augen. Wir erlagen unter der Uebermacht Frankreichs. Der Friede, der die Hälfte meiner Unterthanen mir entriß, gab uns seine Segnungen nicht, denn er schlug uns tiefere Wunden als selbst der Krieg. Das Mark des Landes ward ausgefogen. Die Hauptfestungen blieben vom Feinde besetzt, der Ackerbau ward gelähmt,

ABCDEFGHIJKLMNOPQRSTUVWXYZ&

abcdefghijklmnopqrstuvwxyz

1 2 3 4 5 6 7 8 9 0

, . : ; ! ? () „ * ’ = — fi ff B \$ []

1/8 1/4 3/8 1/2 5/8 3/4 7/8

ä ö ü

fi ff B ff B II d d

True set table characters. Figures and en quad .063; em quad .126; comma, period, and quotations .0315. These sizes will be sent unless otherwise ordered.

Alignment. This face aligns with all 9-point German one- and two-letter faces.

Will run in all machines.

To avoid errors read notice on page six

MERGENTHALER LINOTYPE CO.

10-POINT GERMAN NO. 2
[ONE-LETTER]

Lower case alphabet 11.40 ems

So wenig für mein treues Volk als für Deutsche bedarf es einer Rechenschaft über die Ursachen des Kriegs, welcher jetzt beginnt: klar liegen sie dem unerbundenen Europa vor Augen. Wir erlagen unter der Uebermacht Frankreichs. Der Friede, der die Hälfte meiner Unterthanen mir entriß, gab uns seine Segnungen nicht, denn er schlug uns tiefere Wunden, als selbst der Krieg. Das Mark des Landes ward ausgefogen. Die Hauptfestungen blieben vom Feinde besetzt, der Ackerbau ward gelähmt, sowie der sonst so hochgebrachte Kunstfleiß unserer Städte. Die Freiheit des Handels ward gehemmt, und dadurch die Quelle des ertver-

So wenig für mein treues Volk als für Deutsche bedarf es einer Rechenschaft über die Ursachen des Kriegs, welcher jetzt beginnt: klar liegen sie dem unerbundenen Europa vor Augen. Wir erlagen unter der Uebermacht Frankreichs. Der Friede, der die Hälfte meiner Unterthanen mir entriß, gab uns seine Segnungen nicht, denn er schlug uns tiefere Wunden als selbst der Krieg. Das Mark des Landes ward

ABCDEFGHIJKLMNOPQRSTUVWXYZ&
 abcdefghijklmnopqrstuvwxyz
 1 2 3 4 5 6 7 8 9 0
 , . : ; ! ? () " ' * ' = — fi fl ff B \$ []
 1/8 1/4 3/8 1/2 5/8 3/4 7/8
 ä ö ü
 fi fl B ff B II ch d

True set table characters. Figures and en quad .070; em quad .140; comma and period .035. These sizes will be sent unless otherwise ordered.

Alignment. This face aligns with all 10-point German one- and two-letter faces.

Will run in all machines.

To avoid errors read notice on page six

MERGENTHALER LINOTYPE CO.

6-POINT GERMAN NO. 3 [ONE-LETTER]

Lower case alphabet 14.77 ems

So wenig für mein treues Volk als für Deutsche bedarf es einer Rechenschaft über die Ursachen des Kriegs, welcher jetzt beginnt: Nur liegen sie dem unerblicklichen Europa vor Augen. Wir erlagen unter der Uebermacht Frankreichs. Der Friede, der die Hälfte meiner Untertanen mir entriß, gab uns seine Segnungen nicht, denn er schlug uns tiefere Wunden als selbst der Krieg. Das Mark der Landes ward ausgezogen. Die Hauptfestungen blieben vom Feinde besetzt, der Ackerbau ward gelähmt, sowie der sonst so hochgebrachte Kunstfleiß unserer Städte. Die Freiheit des Handels ward gehemmt und dadurch die Quelle des Erwerbes und des Wohlstandes verstopft. Das Land ward ein Raub der Verarmung. Durch die strengste Erfüllung eingegangener Verbindlichkeiten hoffte ich meinem Volke Erleichterung zu verschaffen, und den französischen Kaiser endlich zu überzeugen, daß es sein eigener Vortheil sei, Preußen seine

So wenig für mein treues Volk als für Deutsche bedarf es einer Rechenschaft über die Ursachen des Kriegs, welcher jetzt beginnt: Nur liegen sie dem unerblicklichen Europa vor Augen. Wir erlagen unter der Uebermacht Frankreichs. Der Friede, der die Hälfte meiner Untertanen mir entriß, gab uns seine Segnungen nicht, denn er schlug uns tiefere Wunden als selbst der Krieg. Das Mark der Landes ward ausgezogen. Die Hauptfestungen blieben vom Feinde besetzt, der Ackerbau ward gelähmt, sowie der sonst so hochgebrachte Kunstfleiß unserer Städte. Die Freiheit des Handels ward gehemmt, und dadurch die Quelle des Erwerbes und des Wohlstandes verstopft. Das Land ward ein Raub der Verarmung. Durch die strengste Erfüllung eingegangener Verbindlichkeiten hoffte ich meinem Volke Erleichterung zu verschaffen und den französischen Kaiser endlich zu überzeugen, daß es sein eigener Vortheil sei, Preußen seine Unab-

ABCDEFGHIJKLMNOPQRSTUVWXYZ

abcdefghijklmnopqrstuvwxyz

1 2 3 4 5 6 7 8 9 0

. . . ; ! ? () „ “ ’ ’ — ß ſ ſ ſ ſ []

¼ ½ ¾ ¼ ½ ¾

ä ö ü

ſ ſ ſ ſ ſ ſ ſ

Special set table characters. Figures and figure space .052; double figure space .104; comma and period .028. These sizes will be sent unless otherwise ordered.

Alignment. This face aligns with all 6-point German one- and two-letter faces.

Will run in all machines.

To avoid errors read notice on page six

MERGENTHALER LINOTYPE CO.

8-POINT GERMAN NO. 3

[ONE-LETTER]

Lower case alphabet 13.11 ems

So wenig für mein treues Volk als für Deutsche bedarf es einer Rechenschaft über die Ursachen des Kriegs, welcher jetzt beginnt: Klar liegen sie dem unerblicketen Europa vor Augen. Wir erlagen unter der Uebermacht Frankreichs. Der Friede, der die Hälfte meiner Unterthanen mir entriß, gab uns seine Segnungen nicht, denn er schlug uns tiefere Wunden, als selbst der Krieg. Das Mark des Landes ward ausgefogen. Die Hauptfestungen blieben vom Feinde besetzt, der Aderbau ward gelähmt, sowie der sonst so hochgebrachte Kunstfleiß unserer Städte. Die Freiheit des Handels ward gehemmt, und dadurch die Quelle des Erwerbes und des Wohlstandes verstopft. Das Land ward ein Raub der Verarmung. Durch die strengste Erfüllung eingegangener Verbindlichkeiten hoffte ich meinem Volke Erleichterung zu verschaffen, und den französischen Kaiser endlich zu überzeu-

So wenig für mein treues Volk als für Deutsche bedarf es einer Rechenschaft über die Ursachen des Kriegs, welcher jetzt beginnt: Klar liegen sie dem unerblicketen Europa vor Augen. Wir erlagen unter der Uebermacht Frankreichs. Der Friede, der die Hälfte meiner Unterthanen mir entriß, gab uns seine Segnungen nicht, denn er schlug uns tiefere Wunden als selbst der Krieg. Das Mark des Landes ward ausgefogen. Die Hauptfestungen blieben vom Feinde besetzt, der Aderbau ward gelähmt, sowie der sonst so hochgebrachte Kunstfleiß

A B C D E F G H I J K L M N O P Q R S T U V W X Y Z &

abcdefghijklmnopqrstuvwxyz

1 2 3 4 5 6 7 8 9 0

, . : ; ! ? () " ' * ' = — fi ff ff \$ []

½ ¼ ⅓ ½ ⅔ ¾ ⅞

ä ö ü

fi ff ff ff ff ff ff

Special set table characters. Figures and figure space .059; double figure space .118; comma and period .0295. These sizes will be sent unless otherwise ordered.

Alignment. This face aligns with all 8-point German one- and two-letter faces.

Will run in all machines.

To avoid errors read notice on page six

MERGENTHALER LINOTYPE CO.

10-POINT GERMAN NO. 3

[ONE-LETTER]

Lower case alphabet 11.83 ems

So wenig für mein treues Volk als für Deutsche bedarf es einer Rechenschaft über die Ursachen des Kriegs, welcher jetzt beginnt: Klar liegen sie dem unverblendeten Europa vor Augen. Wir Erlagen unter der Uebermacht Frankreichs. Der Friede, der die Hälfte meiner Unterthanen mir entriß, gab uns seine Segnungen nicht, denn er schlug uns tiefere Wunden, als selbst der Krieg. Das Mark des Landes ward ausgefogen. Die Hauptfestungen blieben vom Feinde besetzt, der Ackerbau ward gelähmt, sowie der sonst so hochgebrachte Kunstfleiß unserer Städte. Die

So wenig für mein treues Volk als für Deutsche bedarf es einer Rechenschaft über die Ursachen des Kriegs, welcher jetzt beginnt: Klar liegen sie dem unverblendeten Europa vor Augen. Wir erlagen unter der Uebermacht Frankreichs. Der Friede, der die Hälfte meiner Unterthanen mir entriß, gab uns seine Segnungen nicht, denn er schlug uns tiefere Wunden als selbst der Krieg. Das Mark des Landes ward ausgefogen. Die

ABCDEFGHIJKL MNOPQRSTUVWXYZ&

abcdefghijklmnopqrstuvwxyz

1 2 3 4 5 6 7 8 9 0

, . : ; ! ? () " ' - — fi fl ff fb \$ []

1/8 1/4 3/8 1/2 5/8 3/4 7/8

ä ö ü

fi ft fb ff b ll ch d

Special set table characters. Figures and figure space .0665; double figure space .133; comma and period .3325. These sizes will be sent unless otherwise ordered.

Alignment. This face aligns with all 10-point German one- and two-letter faces.

Will run in all machines.

To avoid errors read notice on page six

MERGENTHALER LINOTYPE CO.

11-POINT GERMAN NO. 3
[ONE-LETTER]

Lower case alphabet 11.46 ems

So wenig für mein treues Volk als für Deutsche bedarf es einer Rechenschaft über die Ursachen des Kriegs, welcher jetzt beginnt: Klar liegen sie dem unverblendeten Europa vor Augen. Wir erlagen unter der Uebermacht Frankreichs. Der Friede, der die Hälfte meiner Unterthanen mir entriß, gab uns seine Segnungen nicht, denn er schlug uns tiefere Wunden, als selbst der Krieg. Das Mark des Landes ward ausgefogen. Die Hauptfestungen blieben vom Feinde besetzt, der Ackerbau ward ge-

So wenig für mein treues Volk als für Deutsche bedarf es einer Rechenschaft über die Ursachen des Kriegs, welcher jetzt beginnt: Klar liegen sie dem unverblendeten Europa vor Augen. Wir erlagen unter der Uebermacht Frankreichs. Der Friede, der die Hälfte meiner Unterthanen mir entriß, gab uns seine Segnungen nicht, denn er schlug uns tiefere

ABCDEFGHIJKLMNOPQRSTUVWXYZ&

abcdefghijklmnopqrstuvwxyz

1 2 3 4 5 6 7 8 9 0

, . : ; ! ? () " ' * ' = — fi fl ff lb \$ []

1/8 1/4 3/8 1/2 5/8 3/4 7/8

ä ö ü

fi ft b ff k ll ch c

Special set table characters. Figures and figure space .074; double figure space .148; comma and period .037. These sizes will be sent unless otherwise ordered.

Alignment. This face aligns with all 11-point German one- and two-letter faces.

Will run in all machines.

To avoid errors read notice on page six

MERGENTHALER LINOTYPE CO.

6-POINT
HEBREW
One-Letter

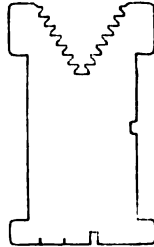

SPECIAL
CHARACTERS

בעטראכטענדיג וואס דיא מענשהיים איז שולדיג צו דער פערנאנענהיים, וועט מען אויסגעפינען, אז זיא איז פיעל מעהר פערפליכטעט צו דיא ערפינדונגען, וואס האבען מעגליך געמאכט אז דיא וויסענשאפט זאלל זיך ווייט פערשפרייטען. דיא ערסטע אונד גרעסטע פון דיעזע ערפינדונגען איז דער אלף בית, אהו וועלכען עס וואללט זעהר שווער געווען זיך צו ערווערבען אדער צו פערשפרייטען דיא וויסענשאפט. איידער דער אלף בית איז ערפונדען געווארען האבען דיא מענשען זעהר וועניג נאכערענט.

בעטראכטענדיג וואס דיא מענשהיים איז שולדיג צו דער פערנאנענהיים, וועט מען אויסגעפינען, אז זיא איז פיעל מעהר פערפליכטעט צו דיא ערפינדונגען, וואס האבען מעגליך געמאכט, אז דיא וויסענשאפט זאלל זיך ווייט פערשפרייטען. דיא

אבגהוזמהיכדקמסנוסעפמףצקשטאצב

' - * () ! ? : ; . ,

” ” „ ” &

0 9 8 7 6 5 4 3 2 1

This face will cast on a 6-point body. The matrices run in the lower case end and center of keyboard.

Table character sizes: en .0484. em .0968. Type foundry's point system. Will run in all machines.

To avoid errors read notice on page six

SPECIMENS OF LINOTYPE FACES

8-POINT HEBREW [ONE-LETTER]

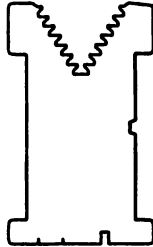

בעמראַכמענדיג וואָס דיא מענשהייט איז שולדיג צו דיא פּערגאַנג-
גענהייט, וועט מען אויסגעפינען, אָז זיא איז פּיעל מעהר פּערפּליכטעט
צו דיא ערפינדונגען, וואָס האַבען מעגליך געמאַכט אָז דיא וויסנשאַפּט
זאלל זיך ווייט פּערשפּרייטען. דיא ערסטע אונד גרעסטע פּון דיעזע ער-
אפינדונגען איז דער אלף בית, אהן וועלכען עס וואַללט זעהר שווער זען
ווען זיך צו ערווערבען אָדער צו פּערשפּרייטען דיא ווסענשאַפּט. אוי-
רדע דער אלף בית איז ערפונדען געוואָרען האַבען דיא מענשען זעהר
וועניג נאכגעדענקט. זיא האַבען אַרויסגעגעבען זייערע געדאַנקען דורך

בעמראַכמענדיג וואָס דיא מענשהייט איז
שולדיג צו דער פּערגאַנגזעהייט, וועט מען
אויסגעפינען, אז זיא איז פּיעל מעהר פּער-
פּליכטעט צו דיא ערפינדונגען, וואָס האַבען
מעגליך געמאַכט, אָז דיא וויסענשאַפּט זאָלל
זיך ווייט פּערשפּרייטען. דיא ערסטע אונד

אבגדהותחיתכלמךנסעפשהצקשתאשאב

ו ו י י ' ' " א

& \$ " " - - * (|) ? ! ; : . .

0 9 8 7 6 5 4 3 2 1

To avoid errors read notice on page six

MERGENTHALER LINOTYPE CO.

8-POINT HEBREW
[ONE-LETTER]

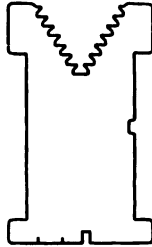

בעטראכטענדיג וואס דיא מענשהייט איז שולדיג צו דער פערנאנגענהייט, וועט מען אויסגעפינען, אז זיא איז פיעל מעהר פערפליכטעט צו דיא ערפינדונגען, וואס האבען מעגליך גע- מאכט אז דיא וויסענשאפט זאלל זיך ווייט פערשפרייטען. דיא ערסטע אונד גרעסטע פון דיעזע ערפינדונגען איז דער אלף בית אהז וועלכע עס וואללט זעהר שווער געווען זיך צו ערווערבען אדער צו פערשפרייטען דיא וויסענשאפט. איידער דער אלף בית איז ערפונדען געווארען האבען דיא מענשען זעהר וועניג נאכגע-

בעטראכטענדיג וואס דיא מענשהייט איז שולדיג צו דער פערנאנגענהייט, וועט מען אויסגעפינען, אז זיא איז פיעל מעהר פערפליכטעט צו דיא ערפינדונגען, וואס האבען מעגליך געמאכט, אז דיא וויסענ- שאפט זאלל זיך ווייט פערשפרייטען. דיא

אבגרהווחטיכדלמסנוסעפףציקרשתאאפ

ו ו י י . . . ' ' " " &

¼ ½ ¾ ⅞ ⅝ ⅜ ⅓ ¼ ⅒

& \$ " " — * (|) ? ! ; : . .

0 9 8 7 6 5 4 3 2 1

To avoid errors read notice on page six

SPECIMENS OF LINOTYPE FACES

11-POINT HEBREW
[ONE-LETTER]

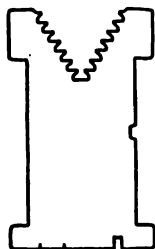

בעטראבמענדיג וואס דיא מענשהיים איז שולדיג צו דער פערגאנגענהיים, וועט מען אויסגעפינען, אז זיא איז פיעל מעהר פערפפליבמעט צו דיא ערפינדונגען, וואס האבען מעגליך געמאכט אז דיא וויסענשאפט זאלל זיך ווייט פער-שפרייטען. דיא ערסטע אונד גרעסטע פון דיעזע ערפינדונגען איז דער אלף בית אהן וועלבען עס וואללט זעהר שווער געווען זיך צו ערוועדבען אדער צו פערשרייטען זי וויסענשאפט. איידער דער אלף בית איז ערפונדען געווארן רען האבען דיא מענשען זעהר וועניג נאכגעדענקט. זייא

בעטראבמענדיג וואס דיא מענשהיים איז שולדיג עו דער פערגאנגענהיים, וועט מען אויסגעפינען, אז זיא איז פיעל מעהר מערפפליבמעט עו דיא ערפינדונגען, וואס האבען מעגליך געמאכט אז דיא וויסענשאפט זאלל זיך

אבגדהוזמטיכךלמסנוסעפףצעקרקשתאצבפ

&	\$	"	"	"	—	-	*	()	§	?	!	;	:	..
0	9	8	7	6	5	4	3	2	1							
⅓	⅔	⅜	¾	⅝	½	⅙	⅚	¼	⅑							

To avoid errors read notice on page six

MERGENTHALER LINOTYPE CO.

8-POINT GREEK
[ONE-LETTER]

Lower case alphabet 12.91 ems

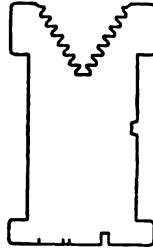

ΤΗΡΕ ΚΤΗΣΙΦΩΝΤΟΣ ΠΕΡΙ ΤΟΥ ΣΤΕΦΑΝΟΥ.

ΠΡΩΤΟΝ μὲν, ὦ ἄνδρες Ἀθηναῖοι, τοῖς θεοῖς εὐχομαι πᾶσι καὶ πάσαις, ὅσων εὐνοίαν ἔχων ἐγὼ διατελῶ τῇ τε πόλει καὶ πᾶσιν ὑμῖν, τοσαύτην ὑπάρξει μοι παρ' ὑμῶν εἰς τούτου τὸν ἀγῶνα, ἔπειθ' ὅπερ ἐστὶ μάλισθ' ὑπὲρ ὑμῶν καὶ τῆς ὑμετέρας εὐσεβείας τε καὶ δόξης, τοῦτο παραστήσαι τοὺς θεοὺς ὑμῖν, μὴ ἐμοῦ δεῖ (σχέτλιον γὰρ ἂν εἴη τοῦτό γε), ἀλλὰ τοὺς νόμους τὸν ἀντίδικον σύμβουλον ποιήσασθαι περὶ τοῦ πῶς ἀκούειν ὑμᾶς καὶ τὸν ὄρκον, ἐν ᾧ πρὸς ἅπασιν τοῖς ἄλλοις δίκαιοις καὶ τοῦτο γέγραπται, τὸ ὁμοίως ἀμφοῖν ἀκροάσασθαι. τοῦτο δ' ἐστὶν οὐ μόνον τὸ μὴ προκατεγνωκέναι μηδέν, οὐδὲ τὸ τὴν εὐνοίαν ἴσῃ ἀμφοτέροις ἀποδοῦναι, ἀλλὰ καὶ το τῇ τάξει καὶ τῇ ἀπολογία, ὡς βεβούληται καὶ προήρηται τῶν ἀγωνιζομένων ἕκαστος, οὕτως ἑᾶσαι χρήσασθαι.

Πολλὰ μὲν οὖν ἔγωγ' ἐλαττοῦμαι κατὰ τούτου τὸν ἀγῶνα Διοχίνου, δύο δ', ὦ ἄνδρες Ἀθηναῖοι, καὶ μεγάλα, ἐν μὲν ὅτι οὐ περὶ τῶν ἴσων ἀγωνίζομαι· οὐ γὰρ ἐστὶν ἴσον νῦν ἐμοὶ τῆς παρ' ὑμῶν εὐνοίας διαμαρτεῖν καὶ τούτω μὴ ἐλεῖν τὴν γραφήν, ἀλλ' ἐμοὶ μὲν--

ΑΒΓΔΕΖΗΘΙΚΑΜΝΞΟΠΡΣΤΤΦΧΨΩ

αβγδεζηθικλμνξοπρστυφψωφ

á à ā ä å æ ç è é ê ë ì í î ï ð ñ ò ó
 ô õ ö ù ú û ü ý ÷ ù ú û ü ý ÷ ù ú û ü ý ÷
 Superior α β π

9

To avoid errors read notice on page six



*Two-Letter
Faces*

SPECIMENS OF LINOTYPE FACES

5½-POINT NO. 1 WITH CLARENDON NO. 1

[TWO-LETTER]

Lower case alphabet 16.29 ems

The most ancient materials employed for recording events were bricks, tiles, shells, and tables of stone. The modes of writing on these different substances were various. The tiles and brick were impressed with a stamp when in a soft state; the shells and tablets of stone were etched or graven, the figures or characters being cut in their surface, and in some cases also stained with various colors. It was by the ancient art of stamping that the walls, palaces, and towers of Babylon were covered with hieroglyphics, which have but recently been brought to light from under the immense mounds of Mesopotamia by Layard and other explorers. The patriarch Job, who is supposed to have lived about 2,300 years after the creation, exclaimed, "O that my words were now written! O that they were printed in a book! that they were graven with an iron pen, and hid in the rock forever." Stung with

The most ancient materials employed for recording events were bricks, tiles, shells, and tables of stone. The modes of writing on these different substances were various. The tiles and brick were impressed with a stamp when in a soft state; the shells and tablets of stone were etched or graven, the figures or characters being cut in their surface, and in some cases also stained with various colors. It was by the ancient art of stamping that the walls, palaces, and towers of Babylon were covered with hieroglyphics, which have but recently been brought to light from under the immense mounds of Mesopotamia by Layard and other explorers. The patriarch Job,

ABCDEFGHIJKLMNOPQRSTUVWXYZ&

ABCDEFGHIJKLMNOPQRSTUVWXYZ&

abcdefghijklmnopqrstuvwxyz

abcdefghijklmnopqrstuvwxyz

1 2 3 4 5 6 7 8 9 0

1 2 3 4 5 6 7 8 9 0

. . . : ! ? () ' ' * - n n n m m n @ £ \$ []
 . . . : ! ? () ' ' * - n n n m m n @ £ \$ []

¼ ¼ ¾ ¾ ¾ ¾

¼ ¼ ¾ ¾ ¾ ¾

Special set table characters. Figures and figure space .046; double figure space .092; comma, period and quotations .031. These sizes will be sent unless otherwise ordered.

Substitute table characters for use with this face can be had as follows:
 5½-point No. 2 with Bold Face No. 2.—Figures and figure space .050; double figure space .100; comma, period, and quotations .028.
 5½-point No. 1 with Bold Face No. 1.—Figures and figure space .063; double figure space .126.

Alignment. This face aligns with all 5½-point one- and two-letter faces except German.
 Will run in all machines.

To avoid errors read notice on page six

MERGENTHALER LINOTYPE CO.

54-POINT NO. 1 WITH ITALIC AND SMALL CAPS

[TWO-LETTER]

Lower case alphabet 15.94 ems

THE MOST ancient materials employed for recording events were bricks, tiles, shells, and tables of stone. The modes of writing on these different substances were various. The tiles and brick were impressed with a stamp when in a soft state; the shells and tablets of stone were etched or graven, the figures or characters being cut in their surface, and in some cases also stained with various colors. It was by the ancient art of stamping that the walls, palaces, and towers of Babylon were covered with hieroglyphics, which have but recently been brought to light from under the immense mounds of Mesopotamia by Layard and other explorers. The patriarch Job, who is supposed to have lived about 2,300 years after the creation, exclaimed, "O that my words were now written! O that they were printed in a book! that they were graven with an iron pen and hid in the rock forever!" Stung with the unjust accusation of his friends, he desires to record his words that the

THE MOST ancient materials employed for recording events were bricks, tiles, shells, and tables of stone. The modes of writing on these different substances were various. The tiles and brick were impressed with a stamp when in a soft state; the shells and tablets of stone were etched or graven, the figures or characters being cut in their surface, and in some cases also stained with various colors. It was by the ancient art of stamping that the walls, palaces, and towers of Babylon were covered with hieroglyphics, which have but recently been brought to light from under the immense mounds of Mesopotamia by Layard and other explorers. The patriarch Job, who is supposed to have lived about 2,300 years after the creation, exclaimed, "O that my words were now written! O that they were printed in a book! that they were graven with an iron pen, and hid

ABCDEFGHIJKLMNQRSTUUVWXYZ&

ABCDEFGHIJKLMNQRSTUUVWXYUN

abcdefghijklmnopqrstuvwxyz

abcdefghijklmnopqrstuvwxyz

1 2 3 4 5 6 7 8 9 0

V B C D E F G R T J

, . : ; ! ? (|) ' ' * - n n n m m e o D \$ £
 , . : ; ! ? A I Q ' ' O - L ß Y ff W M X H D P £

Duplicate Character Matrices.

One-Letter Matrices.

1 2 3 4 5 6 7 8 9 0 ß ff Z & X Z & \$: () @ [] ¼ ½ ¾ % ¼ % ¾ %

Special set table characters. Figures and figure space .050; double figure space .100; comma period, and quotations .031. These sizes will be sent unless otherwise ordered.

Alignment. This face aligns with all 5½-point one- and two-letter faces except German.

Will run in all machines.

To avoid errors read notice on page six

MERGENTHALER LINOTYPE CO.

6-POINT NO. 1 WITH BOLD FACE NO. 2
 [TWO-LETTER]

Lower case alphabet 17.37 ems

The most ancient materials employed for recording events were bricks, tiles, shells, and tables of stone. The modes of writing on these different substances were various. The tiles and brick were impressed with a stamp when in a soft state; the shells and tablets of stone were etched or graven, the figures or characters being cut in their surface, and in some cases also stained with various colors. It was by the ancient art of stamping that the walls, palaces, and towers of Babylon were covered with hieroglyphics, which have but recently been brought to light from under the immense mounds of Mesopotamia by Layard and other explorers. The patriarch Job, who is supposed to have lived about 2,300 years after the creation, exclaimed, "O that my words were now written! O that they were printed in a book! that they were graven with an iron pen, and hid in the rock forever!" Stung with the unjust accusation of his friends, he desires to record his words that the generations following might see the justice of his cause. The English trans-

The most ancient materials employed for recording events were bricks, tiles, shells, and tables of stone. The modes of writing on these different substances were various. The tiles and brick were impressed with a stamp when in a soft state; the shells and tablets of stone were etched or graven, the figures or characters being cut in their surface, and in some cases also stained with various colors. It was by the ancient art of stamping that the walls, palaces, and towers of Babylon were covered with hieroglyphics, which have but recently been brought to light from under the immense mounds of Mesopotamia by Layard and other explorers. The patriarch Job, who is supposed to have lived about 2,300 years after the creation, exclaimed, "O that my words were now written! O that they were printed in a book! that they were graven with an iron pen and hid in the rock forever!" Stung with the unjust

ABCDEFGHIJKLMN OPQRSTUVWXYZ&
 ABCDEFGHIJKLMN OPQRSTUVWXYZ&
 abcdefghijklmnopqrstuvwxyz
 abode fghijklmnopqrstuvwxyz
 1 2 3 4 5 6 7 8 9 0
 1 2 3 4 5 6 7 8 9 0
 . . . ; ! ? (|) * ' ' - - . . . n n n n n n n @ £ \$ []
 . . . ; ! ? (|) * ' ' - - . . . n n n n n n n @ £ \$ []

Special set table characters. Figures and figure space .0484; double figure space .0968; comma, period, and quotations .0277. Unit system, 1/2-point basis. These sizes will be sent unless otherwise ordered.

Alignment. This face aligns with all 6-point one- and two-letter faces except German.

Will run in all machines.

To avoid errors read notice on page six

MERGENTHALER LINOTYPE CO.

6-POINT NO. 1 WITH ITALIC AND SMALL CAPS [TWO-LETTER]

Lower case alphabet 16.58 ems

THE MOST ancient materials employed for recording events were bricks, tiles, shells, and tables of stone. The modes of writing on these different substances were various. The tiles and brick were impressed with a stamp when in a soft state; the shells and tablets of stone were etched or graven, the figures or characters being cut in their surface, and in some cases also stained with various colors. It was by the ancient art of stamping that the walls, palaces, and towers of Babylon were covered with hieroglyphics, which have but recently been brought to light from under the immense mounds of Mesopotamia by Layard and other explorers. The patriarch Job, who is supposed to have lived about 2,300 years after the creation, exclaimed, "O that my words were now written! O that they were printed in a book! that they were graven with an iron pen, and hid

THE MOST ancient materials employed for recording events were bricks, tiles, shells and tables of stone. The modes of writing on these different substances were various. The tiles and brick were impressed with a stamp when in a soft state; the shells and tablets of stone were etched or graven, the figures or characters being cut in their surface, and in some cases also stained with various colors. It was by the ancient art of stamping that the walls, palaces, and towers of Babylon were covered with hieroglyphics, which have but recently been brought to light from under the immense mounds of Mesopotamia by Layard and other explorers. The patriarch Job, who is supposed to have lived about 2,300 years after the creation, exclaimed, "O that my words were now written! O that they were printed in a book! that they were graven with an iron pen, and hid in the rock

ABCDEFGHIJKLMNOPQRSTUVWXYZ&

ABCDEFGHIJKLMNOPQRSTUVWXYZUN

abcdefghijklmnpqrstuvwxyzs

abcdefghijklmnpqrstuvwxyzs

1 2 3 4 5 6 7 8 9 0

V B C D E F G R T J

, . : ; ! ? (|) * ' ' - — . . . ß ſ ſ ſ ſ ſ æ œ £ Œ \$

, . s ; ! ? A I Q O ' ' - — L . . . ſ Y ſ ſ W M K H £ Œ P

Duplicate Character Matrices.

One-Letter Matrices.

1 2 3 4 5 6 7 8 9 0 ſ ſ ſ ſ : Z & () x z & @ [] ¼ ½ ¾ ⅓ ⅔ ⅖ ⅙

Special set table characters. Figures and figure space .056; double figure space .112; comma, period, and quotations .028. These sizes will be sent unless otherwise ordered.

Substitute table characters for use with this face can be had as follows: 6-point No. 2 two-letter.—Figures and figure space .056; double figure space .112; comma, period, and quotations .028.

Alignment. This face aligns with all 6-point one- and two-letter faces except German.

Will run in all machines.

To avoid errors read notice on page six

MERGENTHALER LINOTYPE CO.

7-POINT NO. 1 WITH ITALIC AND SMALL CAPS [TWO-LETTER]

Lower case alphabet 15.11 ems

THE MOST ancient materials employed for recording events were bricks, tiles, shells, and tables of stone. The modes of writing on these different substances were various. The tiles and brick were impressed with a stamp when in a soft state; the shells and tablets of stone were etched or graven, the figures or characters being cut in their surface, and in some cases also stained with various colors. It was by the ancient art of stamping that the walls, palaces, and towers of Babylon were covered with hieroglyphics, which have but recently been brought to light from under the immense mounds of Mesopotamia by Layard and other explorers. The patriarch Job, who is supposed to have lived about 2,300 years after the creation, exclaimed, "O that my

THE MOST ancient materials employed for recording events were bricks, tiles, shells, and tables of stone. The modes of writing on these different substances were various. The tiles and brick were impressed with a stamp when in a soft state; the shells and tablets of stone were etched or graven, the figures or characters being cut in their surface, and in some cases also stained with various colors. It was by the ancient art of stamping that the walls, palaces, and towers of Babylon were covered with hieroglyphics, which have but recently been brought to light from under the immense mounds of Mesopotamia by Layard and other explorers. The patri-

ABCDEFGHIJKLMN OPQRSTUVWXYZ &
ABCDEFGHIJKLMN OPQRSTUVWXYZ UN

abcdefghijklmnopqrstuvwxy z
abcdefghijklmnopqrstuvwxy z

1 2 3 4 5 6 7 8 9 0

V B C D E F G R T J

, . : ; ! ? (|) * ' ' - — . . . f i f f f f f f f f æ œ ð £ \$
, . s ; ! ? A I Q O ' ' - — L . . . f i Y f f W M K H ð £ P

Duplicate Character Matrices

1 2 3 4 5 6 7 8 9 0 f f f f f f \$ Z & : () x z &

One-Letter Matrices

@ [] 1/8 1/4 3/8 1/2 5/8 3/4 7/8

Special set table characters. Figures and figure space .059; double figure space .118; comma, period, and quotations .0295. These sizes will be sent unless otherwise ordered.

Alignment. This face aligns with all 7-point one- and two-letter faces except German.

Will run in all machines.

To avoid errors read notice on page six

MERGENTHALER LINOTYPE CO.

8-POINT NO. 1 WITH ITALIC AND SMALL CAPS [TWO-LETTER]

Lower case alphabet 14.27 ems

THE MOST ancient materials employed for recording events were bricks, tiles, shells, and tables of stone. *The modes of writing on these different substances were various.* The tiles and brick were impressed with a stamp when in a soft state; the shells and tablets of stone were etched or graven, the figures or characters being cut in their surface, and in some cases also stained with various colors. It was by the ancient art of stamping that the walls, palaces, and towers of Babylon were covered with hieroglyphics, which have but recently been brought to light from under the immense

THE MOST ancient materials employed for recording events were bricks, tiles, shells, and tablets of stone. The modes of writing on these different substances were various. The tiles and brick were impressed with a stamp when in a soft state; the shells and tablets of stone were etched or graven, the figures or characters being cut in their surface, and in some cases also stained with various colors. It was by the ancient art of stamping that the walls, palaces,

ABCDEFGHIJKLMNOPQRSTUVWXYZ&
ABCDEFGHIJKLMNOPQRSTUVWXYZUN

abcdefghijklmnopqrstuvwxy
abcdefghijklmnopqrstuvwxy

1 2 3 4 5 6 7 8 9 0

V B C D E F G R T J

. . . : ! ? (|) * ' ' - — . . . fi fl ff fl æ œ ð £ \$
. . . S ; ! ? A I Q O ' ' - — L . . . fl Y ff W M K H ð £ P

Duplicate Character Matrices.

1 2 3 4 5 6 7 8 9 0 fl ff \$ Z & : () x z &

One-Letter Matrices

@ [] ¼ ¼ ¾ ½ ¾ ¾ ¾

Special set table characters. Figures and figure space .059; double figure space .118; comma, period, and quotations .0295. These sizes will be sent unless otherwise ordered.

Substitute table characters for use with this face can be had as follows: 8-point No. 4 figures with 8-point Clarendon No. 1 figures.—Figures and figure space .059; double figure space .118.

Alignment. This face aligns with all 8-point one- and two-letter faces having high alignment except German.

Will run in all machines.

To avoid errors read notice on page six

MERGENTHALER LINOTYPE CO.

10-POINT NO. 1 WITH ITALIC AND SMALL CAPS [TWO-LETTER]

Lower case alphabet 13.20 ems

THE MOST ancient materials employed for recording events were bricks, tiles, shells, and tables of stone. *The modes of writing on these different substances were various.* The tiles and brick were impressed with a stamp when in a soft state; the shells and tablets of stone were etched or graven, the figures or characters being cut in their surface, and in some cases also stained with various colors. It was by the

THE MOST ancient materials used for recording events were bricks, tiles, shells, and tables of stone. The modes of writing on these different substances were various. The tiles and brick were impressed with a stamp when in a soft state; the shells and tables of stone were etched or graven, and in some

ABCDEF GHIJKL MNOPQRST UVWXYZ &
ABCDEF GHIJKL MNOPQRST UVWXYZ UN

abcdefghijklmnopqrstuvwxyz

abcdefghijklmnopqrstuvwxyz

1 2 3 4 5 6 7 8 9 0

V B C D E F G R T J

, . : ; ! ? (|) * ° - — fi fl ff ffi ffl æ œ ð £ \$

, . S ; ! ? A I Q O ° - — L fi Y ff W M K H ð £ P

Duplicate Character Matrices

1 2 3 4 5 6 7 8 9 0 fl ffi ff \$ Z & : () x z &

One-Letter Matrices

@ [] 1/8 1/4 3/8 1/2 5/8 3/4 7/8

True set table characters. Figures and en quad .070; em quad .140; comma, period, and quotations .035. These sizes will be sent unless otherwise ordered.

Alignment. This face aligns with all 10-point one- and two-letter faces except German.

Will run in all machines.

To avoid errors read notice on page six

MERGENTHALER LINOTYPE CO.

11-POINT NO. 1 WITH ITALIC AND SMALL CAPS
[TWO-LETTER]

Lower case alphabet 12.97 ems

THE MOST ancient materials employed for recording events were bricks, tiles, shells, and tables of stone. The modes of writing on these different substances were various. *The tiles and brick were impressed with a stamp* when in a soft state; the shells and tablets of stone were etched or graven, the figures or characters being cut in their surface, and in some cases also stained with

THE MOST ancient materials used for recording events were bricks, tiles, shells, and tables of stone. The modes of writing on these different substances were various. The tiles and brick were impressed with a stamp when in a soft state; the

ABCDEFGHIJKLMN OPQRSTUVWXYZ &
ABCDEFGHIJKLMN OPQRSTUVWXYZ UN
abcdefghijklmnopqrstuvwxy z
abcdefghijklmnopqrstuvwxy z

1 2 3 4 5 6 7 8 9 0

V B C D E F G R T J

Duplicate Character Matrices.

1 2 3 4 5 6 7 8 9 0 fl ffi ff \$ Z & : () x z &

One-Letter Matrices

@ [] 1/8 1/4 3/8 1/2 5/8 3/4 7/8

True set table characters. Figures and en quad .077; em quad .154; comma, period, and quotations .0385. These sizes will be sent unless otherwise ordered.

Alignment. This face aligns with all 11-point one and two-letter faces except German.

Will run in all machines.

To avoid errors read notice on page six

MERGENTHALER LINOTYPE CO.

12-POINT NO. 1 WITH ITALIC AND SMALL CAPS
[TWO-LETTER]

Lower case alphabet 13.39 ems

THE MOST ancient materials employed for recording events were bricks, tiles, shells, and tables of stone. *The modes of writing on these different substances were various.* The tiles and brick were impressed with a stamp when in a soft state; the shells and tablets of stone were etched or graven, the

THE MOST ancient materials used for recording events were bricks, tiles, shells, and tables of stone. The modes of writing on these different substances varied. The tiles and brick were impressed with a stamp when in a soft

ABCDEFGHIJKLMN OPQRSTUVWXYZ &
ABCDEFGHIJKLMN OPQRSTUVWXYZ UN

abcdefghijklmnopqrstuvwxyz
abcdefghijklmnopqrstuvwxyz

1 2 3 4 5 6 7 8 9 0

V B C D E F G R T J

,. : ; ! ? (|) * ' ' - — . . . fi ff ffi ffl æ œ ~~ŷ~~ ~~Ɔ~~ \$
,. S ; ! ? A I Q O ' ' - — L . . . fi Y ff W M K H ~~ŷ~~ ~~Ɔ~~ P

Duplicate Character Matrices.

1 2 3 4 5 6 7 8 9 0 fi ffi ffl Z & \$: () x z &

One-Letter Matrices

@ [] 1/8 1/4 3/8 1/2 5/8 3/4 7/8

True set table characters. Figures and en quad .084; em quad .168; comma, period, and quotations .042. These sizes will be sent unless otherwise ordered.

Substitute table characters for use with this face can be had as follows: 12-point No. 13 figures with Clarendon No. 1 figures.—Figures and en quad .084; em quad .168.

Alignment. This face aligns with all 12-point one- and two-letter faces except German.

Will run in machines Nos. 2, 3, 4 and 5.

To avoid errors read notice on page six

MERGENTHALER LINOTYPE CO.

5½-POINT NO. 2 WITH BOLD FACE NO. 2

[TWO-LETTER]

Lower case alphabet 18.16 ems

The most ancient materials used for recording events were bricks, tiles, shells, and tables of stone. The modes of writing on these different substances were various. The tiles and brick were impressed with a stamp when in a soft state; the shells and tablets of stone were etched or graven, the figures or characters being cut in their surface, and in some cases also stained with various colors. It was by the ancient art of stamping that the walls, palaces, and towers of Babylon were covered with hieroglyphics, which have but recently been brought to light from under the immense mounds of Mesopotamia by Layard and other explorers. The patriarch Job, who is supposed

The most ancient materials employed for recording events were bricks, tiles, shells, and tables of stone. The modes of writing on these different substances were various. The tiles and brick were impressed with a stamp when in a soft state; the shells and tablets of stone were etched or graven, the figures or characters being cut in their surface, and in some cases also stained with various colors. It was by the ancient art of stamping that the walls, palaces, and towers of Babylon were covered with hieroglyphics, which have but recently been brought to light from under the immense mounds of Mesopotamia by Layard and other explorers. The patriarch Job, who

ABCDEFGHIJKLMN OPQRSTUVWXYZ&
ABCDEFGHIJKLMN OPQRSTUVWXYZ&

abcdefghijklmnopqrstuvwxy z
abcdefghijklmnopqrstuvwxy z

1 2 3 4 5 6 7 8 9 0
1 2 3 4 5 6 7 8 9 0

. . . ; ! ? () ' * - . . . n n n n m m @ £ \$ % & []
. . . ; ! ? () ' * - . . . n n n n m m @ £ \$ % & []

¼ ¼ ¼ ¼ ¼ ¼ ¼
¾ ¾ ¾ ¾ ¾ ¾ ¾

Special set table characters. Figures and figure space .050; double figure space .100; comma, period, and quotations .028. These sizes will be sent unless otherwise ordered.

Substitute table characters for use with this face can be had as follows: 5½-point No. 1 with Bold Face No. 2.—Figures and figure space .050; double figure space .100. 5¼-point No. 1 with Bold Face No. 1.—Figures and figure space .063; double figure space .126.

Alignment. This face aligns with all 5½-point one- and two-letter faces except German.

Will run in all machines.

To avoid errors read notice on page six

MERGENTHALER LINOTYPE CO.

7-POINT NO. 2 WITH BOLD FACE NO. 1
[TWO-LETTER]

Lower case alphabet 16.67 ems

The most ancient materials used for recording events were bricks, tiles, shells, and tables of stone. The modes of writing on these different substances were various. The tiles and brick were impressed when in a soft state; the shells and tablets of stone were etched or graven, the figures or characters being cut in their surface, and in some cases stained with various colors. It was by the ancient art of stamping that the walls, palaces, and towers of Babylon were covered with hieroglyphics, which have but recently been brought to light from under the immense mounds of Mesopotamia by Layard and other explorers. The patriarch Job, who is supposed to have lived about 2,300 years

The most ancient materials employed for recording events were bricks, tiles, shells, and tables of stone. The modes of writing on these different substances were various. The tiles and brick were impressed with a stamp when in a soft state; the shells and tablets of stone were etched or graven, the figures or characters being cut in their with various colors. It was by the ancient art of stamping that the walls, palaces, and towers of Babylon were covered with hieroglyphics, which have but recently been brought to light from under the immense mounds of Mesopotamia by Layard and other surface, and in some cases also stained

ABCDEFGHIJKLMN OPQRSTUVWXYZ&
ABCDEFGHIJKLMN OPQRSTUVWXYZ&

abcdefghijklmnopqrstuvwxyz
abcdefghijklmnopqrstuvwxyz

1 2 3 4 5 6 7 8 9 0

1 2 3 4 5 6 7 8 9 0

, . : ; ! ? (|) * ' ' - — fi fi ff ffi ffi lb @ £ \$ []
, . : ; ! ? (|) * ' ' - — fi fi ff ffi ffi lb @ £ \$ []

1/8 1/4 3/8 1/2 5/8 3/4 7/8

1/8 1/4 3/8 1/2 5/8 3/4 7/8

Special set table characters. Figures and figure space .063; double figure space .126; comma, period, and quotations .0315. These sizes will be sent unless otherwise ordered.

Alignment. This face aligns with all 7-point one- and two-letter faces except German.

Will run in all machines.

To avoid errors read notice on page six

MERGENTHALER LINOTYPE CO.

8-POINT NO. 2 WITH BOLD FACE NO. 1 [TWO-LETTER]

Lower case alphabet 15.03 ems

The most ancient materials used for recording events were bricks, tiles, shells, and tables of stone. The modes of writing on these different substances were various. The tiles and brick were impressed with a stamp when in a soft state; the shells and tablets of stone were etched or graven, the figures or characters being cut in their surface, and in some cases also stained with various colors. It was by the ancient art of stamping that the walls, palaces, and towers of Babylon were covered with hieroglyphics, which have but recently been brought to light from under the immense mounds of Mesopotamia by Lay-

The most ancient materials employed for recording events were bricks, tiles, shells, and tables of stone. The modes of writing on these different substances were various. The tiles and brick were impressed with a stamp when in a soft state; the shells and tablets of stone were etched or graven, the figures or characters being cut in their surface, and in some cases also stained with various colors. It was by the ancient art of stamping that the walls, palaces, and towers of Babylon were covered with hieroglyphics,

ABCDEFGHIJKLMN OPQRSTUVWXYZ&
ABCDEFGHIJKLMN OPQRSTUVWXYZ
abcdefghijklmnopqrstuvwxyz
abcdefghijklmnopqrstuvwxyz

1 2 3 4 5 6 7 8 9 0

1 2 3 4 5 6 7 8 9 0

, . : ; ! ? (|) * ' ' - — ñ ñ ñ ñ ñ ñ ñ @ £ \$ []
, . : ; ! ? (|) * ' ' - — ñ ñ ñ ñ ñ ñ ñ @ £ \$ []

1/8 1/4 3/8 1/2 5/8 3/4 7/8
1/8 1/4 3/8 1/2 5/8 3/4 7/8

Special set table characters. Figures and figure space .070; double figure space .140; comma, period, and quotations .035. These sizes will be sent unless otherwise ordered.

Alignment. This face aligns with all 8-point one- and two-letter faces having high alignment except German.

Will run in all machines.

To avoid errors read notice on page six

MERGENTHALER LINOTYPE CO.

6-POINT NO. 2 WITH GOTHIC NO. 3 [TWO-LETTER]

Lower case alphabet 17.74 ems

The most ancient materials used for recording events were bricks, tiles, shells, and tables of stone. The modes of writing on these different substances were various. The tiles and brick were impressed with a stamp when in a soft state; the shells and tablets of stone were etched or graven, the figures or characters being cut in their surface and in some cases also stained with various colors. It was by the ancient art of stamping that the walls, palaces, and towers of Babylon were covered with hieroglyphics, which have but recently been brought to light from under the immense mounds of Mesopotamia by Layard and other explorers. The patriarch Job, who is supposed to have lived about 2,300 years after the creation, exclaimed, "O that my words were now written! O that they were printed in a book! that they were graven with an iron pen, and hid in the rock for-

The most ancient materials employed for recording events were bricks, tiles, shells, and tables of stone. The modes of writing on these different substances were various. The tiles and brick were impressed with a stamp when in a soft state; the shells and tablets of stone were etched or graven, the figures or characters being cut in their surface, and in some cases also stained with various colors. It was by the ancient and towers of Babylon were covered with art of stamping that the walls, palaces, hieroglyphics, which have but recently been brought to light from under the immense mounds of Mesopotamia by Layard and other explorers. The patriarch Job, who is supposed to have lived about 2,300 years after the creation, exclaimed, "O that my words were now written! O that

ABCDEFGHIJKLMNPOQRSTUVWXYZ&
ABCDEFGHIJKLMNPOQRSTUVWXYZ&
abcdefghijklmnopqrstuvwxyz
abcdefghijklmnopqrstuvwxyz

1 2 3 4 5 6 7 8 9 0
1 2 3 4 5 6 7 8 9 0

. . . : ! ? (|) ' ' * - — ñ ñ ñ ñ ñ ñ ñ @ £ \$ []
. . . : ! ? (|) ' ' * - — ñ ñ ñ ñ ñ ñ ñ @ £ \$ []
¼ ¼ ¾ ½ ⅝ ¾ ¾
¼ ¼ ¾ ½ ⅝ ¾ ¾

Special set table characters. Figures and figure space .050; double figure space .100; comma, period, and quotations .031. These sizes will be sent unless otherwise ordered.

Substitute table characters for use with this face can be had as follows: 6-point No. 1 with Clarendon No. 1 two-letter.—Figures and figure space .050; double figure space .100; comma, period, and quotations .031.

Alignment. This face aligns with all 6-point one- and two-letter faces except German.

Will run in all machines.

To avoid errors read notice on page six

MERGENTHALER LINOTYPE CO.

7-POINT NO. 2 WITH GOTHIC NO. 3 [TWO-LETTER]

Lower case alphabet 16.41 ems

The most ancient materials used for recording events were bricks, tiles, shells, and tables of stone. The modes of writing on these different substances were various. The tiles and brick were impressed with a stamp when in a soft state; the shells and tablets of stone were etched or graven, the figures or characters being cut in their surface, and in some cases also stained with various colors. It was by the ancient art of stamping that the walls, palaces, and towers of Babylon were covered with hieroglyphics, which have but recently been brought to light from under the immense mounds of Mesopotamia by Layard and other explorers. The patriarch Job, who is supposed to have lived 2,300 years after the creation, exclaimed, "O that my words were now written! O that

The most ancient materials employed for recording events were bricks, tiles, shells, and tables of stone. The modes of writing on these different substances were various. The tiles and brick were impressed with a stamp when in a soft state; the shells and tablets of stone were etched or graven, the figures or characters being cut in their surface, and in some cases also stained with various colors. It was by the ancient art of stamping that the walls, palaces, and towers of Babylon were covered with hieroglyphics which have but recently been brought to light from under the immense mounds of Mesopotamia

ABCDEFGHIJKLMN OPQRSTUVWXYZ &
ABCDEFGHIJKLMN OPQRSTUVWXYZ &

abcdefghijklmnopqrstuvwxy

abcdefghijklmnopqrstuvwxy

1 2 3 4 5 6 7 8 9 0

1 2 3 4 5 6 7 8 9 0

, . : ; ! ? (|) * ' ' - — fi ff ff ff ff ff ff @ £ \$ []

, . : ; ! ? (|) * ' ' - — fi ff ff ff ff ff ff @ £ \$ []

1/8 1/4 3/8 1/2 5/8 3/4 7/8

1/8 1/4 3/8 1/2 5/8 3/4 7/8

Special set table characters. Figures and figure space .056; double figure space .112; comma, period, and quotations .028. These sizes will be sent unless otherwise ordered.

Alignment. This face aligns with all 7-point one- and two-letter faces except German.

Will run in all machines.

To avoid errors read notice on page six

MERGENTHALER LINOTYPE CO.

8-POINT NO. 2 WITH GOTHIC NO. 3 [TWO-LETTER]

Lower case alphabet 14.51 ems

The most ancient materials used for recording events were bricks, tiles, shells, and tables of stone. The modes of writing on these different substances were various. The tiles and brick were impressed with a stamp when in a soft state; the shells and tablets of stone were etched or graven, the figures or characters being cut in their surface, and in some cases also stained with various colors. It was by the ancient art of stamping that the walls, palaces, and towers of Babylon were covered with hieroglyphics, which have but recently been brought to light from under the immense mounds of Mesopotamia by Layard and other ex-

The most ancient materials employed for recording events were bricks, tiles, shells, and tables of stone. The modes of writing on these different substances were various. The tiles and brick were impressed with a stamp when in a soft state; the shells and tablets of stone were etched or graven, the figures or characters being cut in their surface, and in some cases also stained with various colors. It was by the ancient art of stamping that the walls, palaces, and towers of Babylon were

ABCDEFGHIJKLMN OPQRSTUVWXYZ&
ABCDEFGHIJKLMN OPQRSTUVWXYZ&
abcdefghijklmnopqrstuvwxy

abcdefghijklmnopqrstuvwxy

abcdefghijklmnopqrstuvwxy

1 2 3 4 5 6 7 8 9 0

1 2 3 4 5 6 7 8 9 0

, . : ; ! ? (|) * ' ' - — fi fi ff ffi ffi lb @ £ \$ []

1/8 1/4 3/8 1/2 5/8 3/4 7/8
1/8 1/4 3/8 1/2 5/8 3/4 7/8

Special set table characters. Figures and figure space .059; double figure space .118; comma, period, and quotations .0295. These sizes will be sent unless otherwise ordered.

Substitute table characters for use with this face can be had as follows: 8-point No. 4 figures with 8-point Clarendon No. 1 figures.—Figures and figure space .059; double figure space .118.

Alignment. This face aligns with all 8-point one- and two-letter faces having high alignment except German.
Will run in all machines.

To avoid errors read notice on page six

MERGENTHALER LINOTYPE CO.

8-POINT NO. 2 WITH CONDENSED TITLE NO. 3 [TWO-LETTER]

Lower case alphabet 14.56 ems

The most ancient materials employed for recording events were bricks, tiles, shells, and tables of stone. The modes of writing on these different substances were various. The tiles and brick were impressed with a stamp when in a soft state; the shells and tablets of stone were etched or graven, the figures or characters being cut in their surface, and in some cases also stained with various colors. It was by the ancient art of stamping that the walls, palaces, and towers of Babylon were covered with hieroglyphics, which have but recently been brought to light from under the immense mounds of Mesopotamia by Layard and other ex-

The most ancient materials employed for recording events were bricks, tiles, shells, and tables of stone. The modes of writing on these different substances were various. The tiles and brick were impressed with a stamp when in a soft state; the shells and tablets of stone were etched or graven, the figures or characters being cut in their surface, and in some cases also stained with various colors. It was by the ancient art of stamping that the walls, palaces, and towers of Babylon were

ABCDEFGHIJKLMNOPQRSTUVWXYZ&
ABCDEFGHIJKLMNOPQRSTUVWXYZ&

abcdefghijklmnopqrstuvwxy

abcdefghijklmnopqrstuvwxy

1 2 3 4 5 6 7 8 9 0

1 2 3 4 5 6 7 8 9 0

, . : ; ! ? (|) * ' ' - — ñ ñ ñ ñ ñ ñ @ £ \$ []

, . : ; ! ? (|) * ' ' - — ñ ñ ñ ñ ñ ñ @ £ \$ []

¼ ¼ ¾ ½ ¾ ¾ ¾

¾ ¾ ¾ ¾ ¾ ¾ ¾

Special set table characters. Figures and figure space .05875; double figure space .1175; comma, period, and quotations .0294. Type foundera's point system. These sizes will be sent unless otherwise ordered.

Alignment. This face aligns with all 8-point one- and two-letter faces having low alignment except German.

Will run in all machines.

To avoid errors read notice on page six

MERGENTHALER LINOTYPE CO.

8-POINT NO. 2 WITH 10-POINT CLARENDON [Two-Letter]

Lower case alphabet 15.07 8-point and 12.06 10-point ems

The most ancient materials employed for recording events were bricks, tiles, shells, and tables of stone. The modes of writing on these different substances were various. The tiles and brick were impressed with a stamp when in a

The most ancient materials employed for recording events were bricks, tiles, shells, and tables of stone. The modes of writing on these different substances were various. The tiles and brick were impressed with a stamp when in a

The most ancient materials employed in recording events were bricks, tiles, shells, and tablets of stone. The modes of writing on these different substances were various. The tiles

The most ancient materials employed in recording events were bricks, tiles, shells, and tablets of stone. The modes of writing on these different substances were various. The tiles

ABCDEFGHIJKLMNOPQRSTUVWXYZ&

ABCDEFGHIJKLMNOPQRSTUVWXYZ&

abcdefghijklmnopqrstuvwxyz

abcdefghijklmnopqrstuvwxyz

1 2 3 4 5 6 7 8 9 0

1 2 3 4 5 6 7 8 9 0

, . : ; ! ? (|) * ' ' - — f i f f m m l b @ £ \$ []

, . : ; ! ? (|) * ' ' - — f i f f m m l b @ £ \$ []

1/8 1/4 3/8 1/2 5/8 3/4 7/8

1/8 1/4 3/8 1/2 5/8 3/4 7/8

Special set table characters. Figures and figure space .0692; double figure space .1383; comma, period, and quotations .0345. Type foundry's point system. These sizes will be sent unless otherwise ordered.

Alignment. 8-point No. 2 aligns with all 8-point one- and two-letter faces having high alignment except German. 10-point Clarendon No. 1 aligns with all 10-point one- and two-letter faces except German.

Will run in all machines.

To avoid errors read notice on page six

SPECIMENS OF LINOTYPE FACES

**8-POINT NO. 2
WITH
10-POINT
CLARENDON
NO. 1
Two-Letter**

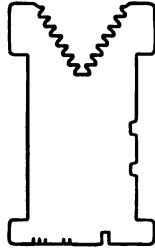

**SPECIAL
CHARACTERS**

1/8	3/8	1/2	5/8	3/4	7/8	1	1 1/8	1 1/4	1 1/2	1 3/4	1 7/8	2	2 1/8	2 1/4	2 1/2	2 3/4	2 7/8	3	3 1/8	3 1/4	3 1/2	3 3/4	3 7/8	4
1/3	2/3	1/5	2/5	3/5	4/5	1/6	5/6	1 1/6	1 1/3	1 1/2	1 2/3	1 5/6	2 1/6	2 1/3	2 1/2	2 2/3	2 5/6	3 1/6	3 1/3	3 1/2	3 2/3	3 5/6	4 1/6	4 1/3
Æ	æ	Œ	œ	¶	§		†	‡	-	¢	/													
Æ	æ	Œ	œ	¶	§		†	‡	-	¢	/													

MERGENTHALER LINOTYPE CO.

6-POINT NO. 2 WITH ANTIQUE NO. 2 [TWO-LETTER]

Lower case alphabet 13.46 ems

The most ancient materials used for recording events were bricks, tiles, shells, and tables of stone. The modes of writing on these different substances were various. The tiles and brick were impressed with a stamp when in a soft state; the shells and tablets of stone were etched or graven, the figures or characters being cut in their surface, and in some cases also stained with various colors. It was by the ancient art of stamping that the walls, palaces, and towers of Babylon were covered with hieroglyphics, which have but recently been brought to light from under the immense mounds of Mesopotamia by Layard and other explorers. The patriarch Job, who is supposed to have lived about 2,300 years after the creation, exclaimed, "O that my words were now written! O that they

The most ancient materials employed for recording events were bricks, tiles, shells, and tables of stone. The modes of writing on these different substances were various. The tiles and brick were impressed with a stamp when in a soft state; the shells and tablets of stone were etched or graven, the figures or characters being cut in their surface, and in some cases also stained with various colors. It was by the ancient art of stamping that the walls, palaces, and towers of Babylon were covered with hieroglyphics, which have but recently been brought to light from under the immense mounds of Mesopotamia by Layard and other explorers. The patriarch Job, who is supposed to have lived about 2,300

ABCDEFGHIJKLMNOPQRSTUVWXYZ&
ABCDEFGHIJKLMNOPQRSTUVWXYZ&

abcdefghijklmnopqrstuvwxy
abcdefghijklmnopqrstuvwxy

1 2 3 4 5 6 7 8 9 0
1 2 3 4 5 6 7 8 9 0

. . . ; ! ? (|) * ' ' - — n n n n n n n n @ £ \$ []
. . . ; ! ? (|) * ' ' - — n n n n n n n n @ £ \$ []
¼ ¼ ½ ½ ¾ ¾
¼ ¼ ½ ½ ¾ ¾

Special set table characters. Figures and figure space .056; double figure space .112; comma, period, and quotations .028. These sizes will be sent unless otherwise ordered.

Substitute table characters for use with this face can be had as follows: 6-point De Vinne with Gothic No. 7 two-letter.—Figures and figure space .056; double figure space .112.

Alignment. This face aligns with all 6-point one- and two-letter faces except German.

Will run in all machines.

To avoid errors read notice on page six

MERGENTHALER LINOTYPE CO.

6-POINT NO. 2 WITH ITALIC AND SMALL CAPS [TWO-LETTER]

Lower case alphabet 17.62 ems

THE most ancient materials used for recording events were bricks, tiles, shells, and tables of stone. The modes of writing on these different substances were various. The tiles and brick were impressed with a stamp when in a soft state; the shells and tablets of stone were etched or graven, the figures or characters being cut in their surface, and in some cases also stained with various colors. It was by the ancient art of stamping that the walls, palaces, and towers of Babylon were covered with hieroglyphics, which have but recently been brought to light from under the immense mounds of Mesopotamia by Layard and other explorers. The patriarch Job, who is supposed to have lived about 2,300 years after the creation, exclaimed, "*O that my words were now written! O that they were printed in a book! that they were graven with an iron pen, and hid in the rock forever!*" Stung with the unjust accusation of his friends, he

THE MOST ancient materials employed for recording events were bricks, tiles, shells, and tables of stone. The modes of writing on these different substances were various. The tiles and brick were impressed with a stamp when in a soft state; the shells and tablets of stone were etched or graven, the figures or characters being cut in their surface, and in some cases also stained with various colors. It was by the ancient art of stamping that the walls, palaces, and towers of Babylon were covered with hieroglyphics, which have but recently been brought to light from under the immense mounds of Mesopotamia by Layard and other explorers. The patriarch Job, who is supposed to have lived about 2,300 years after the creation, exclaimed, "*O that my words were now written! O that they were printed in a book!*"

ABCDEFGHIJKLMN OPQRSTUVWXYZ&
ABCDEFGHIJKLMN OPQRSTUVWXYZUN
abcdefghijklmnopqrstuvwxyz
abcdefghijklmnopqrstuvwxyz
1 2 3 4 5 6 7 8 9 0

V B C D E F G R T J
. . . ; ! ? (|) * ' ' - - . . . ß ſ ſ ſ ſ ſ æ œ ð ð £ \$
, . S ; / P A I Q O ' ' - - L . . . ß Y ſ ſ W M K H ð £ P
Duplicate Character Matrices. One-Letter Matrices.
1 2 3 4 5 6 7 8 9 0 ß ſ ſ \$ Z & : () x z & @ [] ¼ ½ ¾ ⅓ ⅔ ⅕ ⅖

- Special set table characters.** Figures and figure space .056; double figure space .112; comma, period, and quotations .028. These sizes will be sent unless otherwise ordered.
 - Substitute table characters for use with this face can be had as follows:** 6-point No. 1 two-letter.—Figures and figure space .056; double figure space .112; comma, period, and quotations .028.
 - Alignment.** This face aligns with all 6-point one- and two-letter faces except German.
- Will run in all machines.

To avoid errors read notice on page six

MERGENTHALER LINOTYPE CO.

8-POINT NO. 2 WITH ITALIC AND SMALL CAPS [TWO-LETTER]

Lower case alphabet 14.41 ems

THE MOST ancient materials used for recording events were bricks, tiles, shells, and tables of stone. *The modes of writing on these different substances were various.* The tiles and brick were impressed with a stamp when in a soft state; the shells and tablets of stone were etched or graven, the figures or characters being cut in their surface, and in some cases also stained with various colors. It was by the ancient art of stamping that the walls, palaces, and towers of Babylon were covered with hieroglyphics which have, but recently been brought to light from under the immense

THE MOST ancient materials employed for recording events were bricks, tiles, shells, and tables of stone. The modes of writing on these different substances were various. The tiles and brick were impressed with a stamp when in a soft state; the shells and tablets of stone were *etched or graven*, the figures or characters being cut in their surface, and in some cases also stained with various colors. It was by the ancient art of stamping that the walls, palaces, and towers of Babylon were covered

ABCDEFGHIJKLMN O PQRSTU VWXYZ &
ABCDEFGHIJKLMN O PQRSTU VWXYUN

abcdefghijklmnopqrstuvwxyz

abcdefghijklmnopqrstuvwxyz

1 2 3 4 5 6 7 8 9 0

V B C D E F G R T J

, . : ; ! ? (|) * ' ' - — . . . ñ ñ ñ ñ ñ ñ æ œ ð £ \$

, . s ; ! ? A I Q O ' ' - — L . . . ß Y ſ W M K H ð £ P

Duplicate Character Matrices

1 2 3 4 5 6 7 8 9 0 ñ ñ ñ \$ Z & : () x z &

One-Letter Matrices

@ [] 1/8 1/4 3/8 1/2 5/8 3/4 7/8

Special set table characters. Figures and figure space .059; double figure space .118; comma, period, and quotations .0295. These sizes will be sent unless otherwise ordered.

Substitute table characters for use with this face can be had as follows: 8-point No. 4 figures with 8-point Clarendon No. 1 figures.—Figures and figure space .059; double figure space .118.

Alignment. This face aligns with all 8-point one- and two-letter faces having high alignment except German.

Will run in all machines.

to avoid errors read notice on page six

MERGENTHALER LINOTYPE CO.

6-POINT NO. 3 WITH ITALIC AND SMALL CAPS [TWO-LETTER]

Lower case alphabet 16.15 ems

THE MOST ancient materials used for recording events were bricks, tiles, shells and tables of stone. The modes of writing on these different substances were various. The tiles and brick were impressed with a stamp when in a soft state; the shells and tablets of stone were etched or graven, the figures or characters being cut in their surface, and in some cases also stained with various colors. It was by the ancient art of stamping that the walls, palaces, and towers of Babylon were covered with hieroglyphics, which have but recently been brought to light from *under the immense mounds of Mesopotamia* by Layard and other explorers. The patriarch Job, who is supposed to have lived about 2,300 years after the creation, exclaimed, "*O that my words were now written! O that they were printed in a book! that they were graven with an iron pen, and hid in the rock forever!*" Stung with the unjust accusation of his friends, he desires to record his words that the generations following

THE MOST ancient materials employed for recording events were bricks, tiles, shells, and tables of stone. The modes of writing on these different substances were various. The tiles and brick were impressed with a stamp when in a soft state; the shells and tablets of stone were etched or graven, the figures or characters being cut in their surface, and in some cases also stained with various colors. It was by the ancient art of stamping that the walls, palaces, and towers of Babylon were covered with hieroglyphics, which have but recently been brought to light from under the immense mounds of Mesopotamia by Layard and other explorers. The patriarch Job, who is supposed to have lived about 2,300 years after the creation, exclaimed, "*O that my words were now written! O that they were printed in a book! that they were graven with an iron pen, and hid in the rock forever!*" Stung with the un-

ABCDEFGHIJKLMN O P Q R S T U V W X Y Z &
ABCDEFGHIJKLMN O P Q R S T U V W X Y Z U N
abcdefghijklmnopqrstuvwxyz
abcdefghijklmnopqrstuvwxyz
1 2 3 4 5 6 7 8 9 0
V B C D E F G R T J

. . . ; ! ? (|) * ' ' - - . . . ñ ñ ñ ñ ñ ñ ñ ñ ñ ñ ñ ñ ñ ñ ñ ñ ñ
. . . 8 ; ! ? A I Q O ' ' - - L . . . ß Y ß W M K H ß ß P
Duplicate Character Matrices. One-Letter Matrices.
1 2 3 4 5 6 7 8 9 0 ß ñ ñ \$ Z & : (.) x z & @ [] ¼ ½ ¾ ⅜ ⅝ ⅞ ⅛

Special set table characters. Figures and figure space .056; double figure space .112; comma, period, and quotations .028. These sizes will be sent unless otherwise ordered.

Substitute table characters for use with this face can be had as follows: 6-point No. 1 two-letter.—Figures and figure space .056; double figure space .112; comma, period, and quotations .028.

Alignment. This face aligns with all 6-point one- and two-letter faces except German.

Will run in all machines.

To avoid errors read notice on page six

MERGENTHALER LINOTYPE CO.

8-POINT NO. 4 WITH ITALIC AND SMALL CAPS [TWO-LETTER]

Lower case alphabet 14.59 ems

THE MOST ancient materials used for recording events were bricks, tiles, shells, and tables of stone. *The modes of writing on these different substances were various.* The tiles and brick were impressed with a stamp when in a soft state; the shells and tablets of stone were etched or graven, the figures or characters being cut in their surface, and in some cases also stained with various colors. It was by the ancient art of stamping that the walls, palaces, and towers of Babylon were covered with hieroglyphics, which have but recently been brought to light from under the

THE MOST ancient materials used for recording events were bricks, tiles, shells, and tables of stone. The modes of writing on these different substances were various. The tiles and brick were impressed with a stamp when in a soft state; the shells and tablets of stone were etched or graven, the figures or characters being cut in their surface, and in some cases also stained with various colors. It was by the ancient art of stamping that the walls, palaces, and towers of Babylon

ABCDEFGHIJKLMN OPQRSTUVWXYZ &
ABCDEFGHIJKLMN OPQRSTUVWXYZ UN

abcdefghijklmnopqrstuvwxy z

abcdefghijklmnopqrstuvwxyz

1 2 3 4 5 6 7 8 9 0

V B C D E F G H T J

, . : ; ! ? (|) * ' ' - — . . . fl fl ff ffi ffl æ œ lb £ \$

, . s ; ! ? A I Q O ' ' - — L . . . fl Y ff W M K H lb £ P

Duplicate Character Matrices

1 2 3 4 5 7 6 8 9 0 fl ff ffi \$ Z & : () x z &

One-Letter Matrices

@ [] 1/8 1/4 3/8 1/2 5/8 3/4 7/8

Special set table characters. Figures and figure space .059; double figure space .118; comma, period, and quotations .0295. These sizes will be sent unless otherwise ordered.

Substitute table characters for use with this face can be had as follows: 8-point No. 4 figures with 8-point Clarendon No. 1 figures.—Figures and figure space .059; double figure space .118.

Alignment. This face aligns with all 8-point one- and two-letter faces having high alignment except German.

Will run in all machines.

To avoid errors read notice on page six

MERGENTHALER LINOTYPE CO.

10-POINT NO. 5 WITH ITALIC AND SMALL CAPS
[TWO-LETTER]

Lower case alphabet 12.26 ems

THE MOST ancient materials employed for recording events were bricks, tiles, shells, and tables of stone. *The modes of writing on these different substances were various.* The tiles and brick were impressed with a stamp when in a soft state; the shells and tablets of stone were etched or graven, the figures or characters being cut in their surface, and in some cases also stained with various colors. It was by the

THE MOST ancient materials used for recording events were bricks, tiles, shells, and tables of stone. *The modes of writing on these different substances were various.* The tiles and brick were impressed with a stamp when in a soft state; the shells and tablets of stone were etched or graven, the figures or characters being cut in their sur-

ABCDEFGHIJKLMN OPQRSTUVWXYZ
ABCDEFGHIJKLMN OPQRSTUVWXYZ
abcdefghijklmnopqrstu vwxyz
abcdefghijklmnopqrstu vwxyz

1 2 3 4 5 6 7 8 9 0

V B C D E F G R T J

, . : ; ! ? (|) * ' ' - — fi ff ffi ffl æ œ ð £ \$
, . S ; ! ? A I Q O ' ' - — L fi Y ff W M K H ð £ P

Duplicate Character Matrices

1 2 3 4 5 6 7 8 9 0 fl ffi ffl \$ Z & : () x z &

One-Letter Matrices

@ [] 1/8 1/4 3/8 1/2 5/8 3/4 7/8

Special set table characters. Figures and figure space .0761; double figure space .1521; comma, period, and quotations .038. Unit system, 1/4-point basis. These sizes will be sent unless otherwise ordered.

Alignment. This face aligns with all 10-point one- and two-letter faces except German.

Will run in all machines.

To avoid errors read notice on page six

MERGENTHALER LINOTYPE CO.

10-POINT NO. 6 WITH ITALIC AND SMALL CAPS
[TWO-LETTER]

Lower case alphabet 13.51 ems

THE MOST ancient materials employed for recording events were bricks, tiles, shells, and tables of stone. *The modes of writing on these different substances were various.* The tiles and brick were impressed with a stamp when in a soft state; the shells and tablets of stone were etched or graven, the figures or characters being cut in their surface, and in some cases also stained with various colors. It was by the ancient art of stamping that the walls, palaces, and

THE MOST ancient materials used for recording events were bricks, tiles, shells, and tables of stone. The modes of writing on these different substances were various. The tiles and brick were impressed with a stamp when in a soft state; the shells and tablets of stone were etched or graven, the figures or characters being cut in

ABCDEFGHIJKLMN OPQRSTUVWXYZ&
ABCDEFGHIJKLMN OPQRSTUVWXYZUN

abcdefghijklmnopqrstuvwxy
abcdefghijklmnopqrstuvwxy

1 2 3 4 5 6 7 8 9 0

V B C D E F G R T J

, . : ; ! ? (|) * ' - — . . . fi fl ff ffi ffl æ œ ð £ \$
, . S ; ? A I Q O ' ' - — L . . . fi Y ff W M K H ð £ P

Duplicate Character Matrices

1 2 3 4 5 6 7 8 9 0 fl ffi ffl \$ Z & : () x z &

One-Letter Matrices

@ [] 1/8 1/4 3/8 1/2 5/8 3/4 7/8

True set table characters. Figures and en quad .070; em quad .140; comma, period, and quotations .035. These sizes will be sent unless otherwise ordered.

Alignment. This face aligns with all 10-point one- and two-letter faces except German.

Will run in all machines.

To avoid errors read notice on page six

MERGENTHALER LINOTYPE CO.

10-POINT NO. 9 WITH ITALIC AND SMALL CAPS
[TWO-LETTER]

Lower case alphabet 12.43 ems

THE MOST ancient materials employed for recording events were bricks, tiles, shells, and tables of stone. *The modes of writing on these different substances were various.* The tiles and brick were impressed with a stamp when in a soft state; the shells and tablets of stone were etched or graven, the figures or characters being cut in their surface, and in some cases also stained with various colors. It was by the ancient art of stamping that

THE MOST ancient materials used for recording events were bricks, tiles, shells, and tables of stone. *The modes of writing on these different substances were various.* The tiles and brick were impressed with a stamp when in a soft state; the shells and tablets of stone were etched or graven, the figures or characters being cut in their sur-

ABCDEFGHIJKLMNOPQRSTUVWXYZ&
ABCDEFGHIJKLMNOPQRSTUVWXYZUN

abcdefghijklmnopqrstuvwxyz
abcdefghijklmnopqrstuvwxyz

1 2 3 4 5 6 7 8 9 0

V B C D E F G R T J

, . : ; ! ? (|) * ' - — . . . fi fl ff ffi ffl æ œ ð £ \$
, . s ; ! ? A I Q O ' ' - — L . . . fi Y ff W M K H ð £ P

One-Letter Matrices

1 2 3 4 5 6 7 8 9 0 fl ffi ffl \$ Z & : () x z &

Duplicate Character Matrices.

@ [] 1/8 1/4 3/8 1/2 5/8 3/4 7/8

True set table characters. Figures and en quad .0691; em quad .1383; comma, period, and quotations .0345. Unit system, 1/4-point basis. These sizes will be sent unless otherwise ordered.

Alignment. This face aligns with all 10-point one- and two-letter faces except German.

Will run in all machines.

To avoid errors read notice on page six

MERGENTHALER LINOTYPE CO.

11-POINT NO. 9 WITH ITALIC AND SMALL CAPS
[TWO-LETTER]

Lower case alphabet 11.86 ems

THE MOST ancient materials employed for recording events were bricks, tiles, shells, and tables of stone. *The modes of writing on these different substances were various.* The tiles and brick were impressed with a stamp when in a soft state; the shells and tablets of stone were etched or graven, the figures or characters being cut in their surface, and in some,

THE MOST ancient materials used for recording events were bricks, tiles, shells, and tables of stone. The modes of writing on these different substances were various. The tiles and brick were impressed with a stamp when in a soft state; the shells and tablets of stone were etched or graven, the figures or characters being cut in their

ABCDEFGHIJKLMN OPQRSTUVWXYZ
ABCDEFGHIJKLMN OPQRSTUVWXYZUN

abcdefghijklmnopqrstuvwxy
abcdefghijklmnopqrstuvwxy

1 2 3 4 5 6 7 8 9 0

V B C D E F G R T J

, . : ; ! ? (|) * ' - — . . . fi ff ffi ffl æ œ ð £ \$
, . S ; ! ? A I Q O ' ' - — L . . . fi Y ff W M K H ð £ P

Duplicate Character Matrices.

1 2 3 4 5 6 7 8 9 0 fl ffi ffl \$ Z & : () x z &

One-Letter Matrices

@ [] 1/8 1/4 3/8 1/2 5/8 3/4 7/8

True set table characters. Figures and en quad .077; em quad .154; comma, period, and quotations .0385. These sizes will be sent unless otherwise ordered.

Alignment. This face aligns with all 11-point one and two-letter faces except German.

Will run in all machines.

To avoid errors read notice on page six

MERGENTHALER LINOTYPE CO.

5-POINT NO. 10 WITH GOTHIC NO. 4

[TWO-LETTER]

Lower case alphabet 15.46 ems.

The most ancient materials employed for recording events were bricks, tiles, shells, and tables of stone. The modes of writing on these different substances were various. The tiles and brick were impressed with a stamp when in a soft state; the shells and tablets of stone were etched or graven, the figures or characters being cut in their surface, and in some cases also stained with various colors. It was by the ancient art of stamping that the walls, palaces, and towers of Babylon were covered with hieroglyphics, which have but recently been brought to light from under the immense mounds of Mesopotamia by Layard and other explorers. The patriarch Job, who is supposed to have lived about 2,300 years after the creation, exclaimed, "O that my words were now written! O that they were printed in a book! that they were graven with an iron pen, and hid in the rock forever." Stung with the unjust accusation of his friends, he desires to record his words that the generations following might see the justice of his cause. The English translation has given the allusion to printing to the text, the original word signifying rather to engrave on a plate, which was doubtless the only printing known to Job. Montfaucon purchased at Rome in 1699 an ancient book entirely composed of lead. It was about four inches long and three

The most ancient materials employed for recording events were bricks, tiles, shells, and tables of stone. The modes of writing on these different substances were various. The tiles and brick were impressed with a stamp when in a soft state; the shells and tablets of stone were etched or graven, the figures or characters being cut in their surface, and in some cases also stained with various colors. It was by the ancient art of stamping that the walls, palaces, and towers of Babylon were covered with hieroglyphics, which have but recently been brought to light from under the immense mounds of Mesopotamia by Layard and other explorers. The patriarch Job, who is supposed to have lived about 2,300 years after the creation, exclaimed, "O that my words were now written! O that they were printed in a book! that they were graven with an iron pen, and hid in the rock forever!" Stung with the unjust accusation of his friends, he desires to record his words that the generations following might see the justice of his cause.

ABCDEFGHIJKLMN OPQRSTU VWXYZ&
ABCDEFGHIJKLMN OPQRSTU VWXYZ&

abcdefghijklmnopqrstu vwxyz
abcdefghijklmnopqrstu vwxyz

1 2 3 4 5 6 7 8 9 0
1 2 3 4 5 6 7 8 9 0

. . . : ? ! (|) ' ' * - - - n n n n m m m £ \$ [] @
. . . : ? ! (|) ' ' * - - - n n n n m m m £ \$ [] @

¼ ¼ ¼ ¼ ¼ ¼ ¼
½ ½ ½ ½ ½ ½ ½

Special set table characters. Figures and figure space .0415; double figure space .083; comma and period .0277. Unit system ¼-point basis. These sizes will be sent unless otherwise ordered.

Alignment. This face aligns with all 5-point one- and two-letter matrices except German.

Will run in all machines.

To avoid errors read notice on page six

MERGENTHALER LINOTYPE CO.

6-POINT NO. 12 WITH ITALIC AND SMALL CAPS [TWO-LETTER]

Lower case alphabet 14.55 ems

THE MOST ancient materials used for recording events were bricks, tiles, shells, and tables of stone. The modes of writing on these different substances were various. The tiles and brick were impressed with a stamp when in a soft state; the shells and tablets of stone were etched or graven, the figures or characters, being cut in their surface, and in some cases also stained with various colors. It was by the ancient art of stamping that the walls, palaces, and towers of Babylon were covered with hieroglyphics, which have but recently been brought to light from under the immense mounds of Mesopotamia by Layard and other explorers. The patriarch Job, who is supposed to have lived about 2,300 years after the creation, exclaimed, " *O that my words were now written! O that they were printed in a book! that they were graven with an iron pen, and hid in the rock forever!*" Stung with the unjust accusation of his friends, he desires to record his words that the generations following might see the justice of his cause. The English translation has

THE MOST ancient materials used for recording events were bricks, tiles, shells, and tables of stone. The modes of writing on these different substances were various. The tiles and brick were impressed with a stamp when in a soft state; the shells and tablets of stone were etched or graven, the figures or characters being cut in their surface, and in some cases also stained with various colors. It was by the ancient art of stamping that the walls, palaces, and towers of Babylon were covered with hieroglyphics, which have but recently been brought to light from under the immense mounds of Mesopotamia by Layard and other explorers. The patriarch Job, who is supposed to have lived about 2,300 years after the creation, exclaimed, " *O that my words were now written! O that they were printed in a book! that they were graven with*

ABCDEFGHIJKLMN OPQRSTUVWXYZ&
ABCDEFGHIJKLMN OPQRSTUVWXYZUN

abcdefghijklmnopqrstuvwxyz
abcdefghijklmnopqrstuvwxyz

1 2 3 4 5 6 7 8 9 0

V B C D E F G R T J

, . : ; ! ? () * ' ' - . . . ß ſ ſ ſ ſ x œ ð £ \$
, . s ; ! ? A I Q O ' ' - L . . . ſ y ſ ſ w m k h ð £ P

Duplicate Character Matrices.

One-Letter Matrices.

1 2 3 4 5 6 7 8 9 0 ſ ſ ſ ſ \$ Z & : () x z * @ [] ¼ ½ ¾ ¼ ½ ¾ ¼ ¾

Special set table characters. Figures and figure space .050; double figure space .100; comma, period, and quotations .028. These sizes will be sent unless otherwise ordered.

Substitute table characters for use with this face can be had as follows: 6-point No. 1 two-letter.—Figures and figure space .056; double figure space .112; comma, period, and quotations .028.

Alignment. This face aligns with all 6-point one- and two-letter faces except German.

Will run in all machines.

To avoid errors read notice on page six

MERGENTHALER LINOTYPE CO.

9-POINT NO. 18 WITH ITALIC AND SMALL CAPS
[TWO-LETTER]

Lower case alphabet 13.10 ems

THE MOST ancient materials employed for recording events were bricks, tiles, shells, and tables of stone. *The modes of writing on these different substances were various.* The tiles and brick were impressed with stamp when in a soft state; the shells and tablets of stone were etched or graven, the figures or characters being cut in their surface, and in some cases also stained with various colors. It was by the ancient art of stamping that the walls, palaces, and towers of Babylon were covered with hieroglyphics, which have

THE MOST ancient materials used for recording events were bricks, tiles, shells, and tablets of stone. The modes of writing on these different substances were various. The tiles and brick were impressed with a stamp when in a soft state; the shells and tablets of stone were etched or graven, the figures or characters being cut in their surface, and in some cases also stained with various colors. It was by the ancient art of stamping

ABCDEFGHIJKLMN OPQRSTUVWXYZ &
ABCDEFGHIJKLMN OPQRSTUVWXYZ

abcdefghijklmnopqrstuvwxy z

abcdefghijklmnopqrstuvwxy z

1 2 3 4 5 6 7 8 9 0

V B C D E F G R T J

, . : ; ! ? (|) * ' ' - — . . . fi fl ff ffi ffl œ œ ð £ \$

, . S ; ! ? A I Q O ' ' - — L . . . fi y ff W M K H ð £ P

Duplicate Character Matrices

1 2 3 4 5 6 7 8 9 0 fl ffi ffl \$ Z & : () X Z &

One-Letter Matrices

@ [] 1/8 1/4 3/8 1/2 5/8 3/4 7/8

True set table characters. Figures and en quad .063; em quad .126; comma, period, and quotations .0315. These sizes will be sent unless otherwise ordered.

Alignment. This face aligns with all 9-point one- and two-letter faces except German.

Will run in all machines.

To avoid errors read notice on page six

MERGENTHALER LINOTYPE CO.

10-POINT NO. 18 WITH ITALIC AND SMALL CAPS [TWO-LETTER]

Lower case alphabet 12.26 ems

THE MOST ancient materials used for recording events were bricks, tiles, shells, and tables of stone. *The modes of writing on these different substances were various.* The tiles and brick were impressed with a stamp when in a soft state; the shells and tablets of stone were etched or graven, the figures or characters being cut in their surface, and in some cases also stained with various colors. It was by the ancient art of stamping that the walls, palaces, and towers of Babylon were covered with

THE MOST ancient materials used for recording events were bricks, tiles, shells, and tables of stone. The modes of writing on these different substances were various. The tiles and brick were impressed with a stamp when in a soft state; the shells and tablets of stone were etched or graven, the figures or characters being cut in their surface, and in some

ABCDEFGHIJKLMN OPQRST UVWXYZ &
ABCDEFGHIJKLMN OPQRST UVWXYZ UN

abcdefghijklmnopqrstuvwxyz
abcdefghijklmnopqrstuvwxyz

1 2 3 4 5 6 7 8 9 0

V B C D E F G R T J

, . : ; ? ! (|) * ' - . . . fi ff ffi ffi æ œ ð \$ &
, . S ; ? ! A I Q O ' - L . . . fi Y ff W M K H ð P N

Duplicate Character Matrices.

@ [] 1/8 1/4 3/8 1/2 5/8 3/4 7/8

One-Letter Matrices

1 2 3 4 5 6 7 8 9 0 ffi ffl \$ Z & : () x z &

True set table characters. Figures and en quad .070; em quad .140; comma, period, and quotations .035. These sizes will be sent unless otherwise ordered.

Alignment. This face aligns with all 10-point one- and two-letter faces except German.

Will run in all machines.

To avoid errors read notice on page six

MERGENTHALER LINOTYPE CO.

8-POINT NO. 19 WITH TITLE NO. 1 [TWO-LETTER]

Lower case alphabet 13.67 ems

The most ancient materials employed for recording events were bricks, tiles, shells, and tables of stone. The modes of writing on these different substances were various. The tiles and brick were impressed with a stamp when in a soft state; the shells and tablets of stone were etched or graven, the figures or characters being cut in their surface, and in some cases also stained with various colors. It was by the ancient art of stamping that the walls, palaces, and towers of Babylon were covered with hieroglyphics, which have but recently been brought to light from under the immense mounds of Mesopotamia by Lay-

The most ancient materials employed for recording events were bricks, tiles, shells, and tables of stone. The modes of writing on these different substances were various. The tiles and brick were impressed with a stamp when in a soft state; the shells and tablets of stone were etched or graven, the figures or characters being cut in their surface, and in some cases also stained with various colors. It was by the ancient art of stamping that the walls, palaces, and towers of Babylon were covered with

ABCDEFGHIJKLMNOPQRSTUVWXYZ&
ABCDEFGHIJKLMNOPQRSTUVWXYZ&

abcdefghijklmnopqrstuvwxyz

abcdefghijklmnopqrstuvwxyz

1 2 3 4 5 6 7 8 9 0

1 2 3 4 5 6 7 8 9 0

, . : ; ! ? (|) * ' ' - - fi fi fi fi fi lb @ £ \$ []

, . : ; ! ? (|) * ' ' - - fi fi fi fi fi lb @ £ \$ []

1/8 1/4 3/8 1/2 5/8 3/4 7/8

1/8 1/4 3/8 1/2 5/8 3/4 7/8

True set table characters. Figures and en quad .056; em quad .112; comma, period, and quotations .028. These sizes will be sent unless otherwise ordered.

Substitute table characters for use with this face can be had as follows: 8-point No. 19 with Title No. 1 Modernized figures.—Figures and en quad .056; em quad .112.

Alignment. This face aligns with all 8-point one- and two-letter faces having high alignment except German.

Will run in all machines.

To avoid errors read notice on page six

MERGENTHALER LINOTYPE CO.

8-POINT CENTURY EXPANDED WITH ITALIC AND SMALL CAPS [TWO-LETTER]

Lower case alphabet 14.72 ems

THE MOST ancient materials used for recording events were bricks, tiles, shells, and tables of stone. *The modes of writing on these different substances were various.* The tiles and brick were impressed with a stamp when in a soft state; the shells and tablets of stone were etched or graven, the figures or characters being cut in their surface, and in some cases also stained with various colors. It was by the ancient art of stamping that the walls, palaces, and towers of Babylon were covered with hieroglyphics, which have but recently been brought to light from under the immense mounds of Mesopotamia by Layard and other explorers.

THE MOST ancient materials used for recording events were bricks, tiles, shells, and tables of stone. The modes of writing on these different substances were various. The tiles and brick were impressed with a stamp when in a soft state; the shells and tablets were etched or graven, the figures or characters being cut in their surface, and in some cases also stained with various colors. It was by the ancient art of stamping that the walls, palaces, and towers of Babylon were covered with hieroglyphics, which have but recently

ABCDEFGHIJKLMN OPQRSTUVWXYZ&
ABCDEFGHIJKLMN OPQRSTUVWXYZUN
abcdefghijklmnopqrstuvwxyz
abcdefghijklmnopqrstuvwxyz

1 2 3 4 5 6 7 8 9 0

V B C D E F G R T J

,. S ; ! ? A I Q O ' ' - — L . . . fi Y ff W M K H B E P
,. S ; ! ? A I Q O ' ' - — L . . . fi Y ff W M K H B E P

Duplicate Character Matrices

1 2 3 4 5 6 7 8 9 0 fi ffi ffi \$ Z & : () x z &

One-Letter Matrices

@ [] ¼ ¼ ¾ ½ ¾ ¾ ¾

Special set table characters. Figures and figure space .063; double figure space .126; comma, period, and quotations .0315. These sizes will be sent unless otherwise ordered.

Alignment. This face aligns with all 8-point one- and two-letter faces having low alignment except German.

Will run in all machines.

To avoid errors read notice on page six

SPECIMENS OF LINOTYPE FACES

**8-POINT
CENTURY
EXPANDED
WITH
ITALIC AND
SMALL CAPS
Two-Letter**

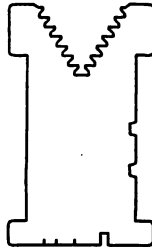

**SPECIAL
CHARACTERS**

Low Cap Accents—Regular mold may be used.

À Á Â Ã Ä Ç È É Ê Ë Ì Í Î Ï Ñ Ò Ó Ô Õ Ö Ù Ú Û
 à á â ã ä å ç è é ê ë ì í î ï ñ ò ó ô õ ö ù ú û

á â ã ä å Æ Ç È É Ê Ë Ì Í Î Ï Ñ Ò Ó Ô Õ Ö Ù Ú Û
 á à á ä å ã ä å ç è é ê ë ì í î ï ñ ò ó ô õ ö ù ú û

Ì Í Î Ñ Ò Ó Ô Õ Ö Ù Ú Û Ü Ý Þ ß à á â ã ä å æ ç è é ê ë ì í î ï ñ ò ó ô õ ö ù ú û

Æ æ Œ œ Z fi ffi fl : \$ 1 2 3 4 5 6 7 8 9 0
 Æ æ Œ œ Z fl ffi fl : L \$ 1 2 3 4 5 6 7 8 9 0

Duplicate Character Matrices.

Æ Œ fi fl

Small Cap Accent in Auxillary Position: é

One-letter Matrices to be used for two-letter work

§ ¶ || † ‡ - μ ij / + × ÷ =
 1/3 2/3 1/5 2/5 3/5 4/5 1/6 5/6 1/8 3/8 5/8 7/8 1/10 3/10 7/10 9/10
 1234567890 abcdefghijklmnopqrstuvwxyz 1234567890
 cm. nk ns rv · ÷ ð ñ ò + - × = () [] ■ ● ▲ ★ * + - × . () []

abcdefghijklmnopqrstuvcxyz ! abcdefghijklmnopqrstuvcxyz

Piece Fractions—Upper half: 1,2,3,4,5,6,7,8,9,0 Lower half: 1,2,3,4,5,6,7,8,6

Plain Figures for Piece Fractions—Upper: 1234567890 Lower: 1234567800

1/2 1/4 1/8 3/8 1/10 3/10 7/10 9/10 1/16 1/8 3/8 1/2 3/4 1/2 + 7 1/2 + φ () 1905 1906 1907
 1908 1909 1910 1911 1912 1913 1914 1915 1916 1917 1918 1919 1920 1921 1922 1923 1924 1925 1926 1927 1928 1929 1930 1931 1932 1933 1934 1935 1936 1937 1938 1939 1940 1941 1942 1943 1944 1945 1946 1947 1948 1949 1950 1951 1952 1953 1954 1955 1956 1957 1958 1959 1960 1961 1962 1963 1964 1965 1966 1967 1968 1969 1970 1971 1972 1973 1974 1975 1976 1977 1978 1979 1980 1981 1982 1983 1984 1985 1986 1987 1988 1989 1990 1991 1992 1993 1994 1995 1996 1997 1998 1999 2000

OR GRO LBS DOZ SET MORE PR ☉ ☽ ☾ ☿ ♀ ♂ ♁ ♃ ♄ ♅ ♆ ♇ ♈ ♉ ♊ ♋ ♌ ♍ ♎ ♏ ♐ ♑ ♒ ♓ ♔ ♕ ♖ ♗ ♘ ♙ ♚ ♛ ♜ ♝ ♞ ♟ ♠ ♡ ♢ ♣ ♤ ♥ ♦ ♧ ♨ ♩ ♪ ♫ ♬ ♭ ♮ ♯ ♰ ♱ ♲ ♳ ♴ ♵ ♶ ♷ ♸ ♹ ♺ ♻ ♼ ♽ ♾ ♿ ♂ ♀ ♁ ♃ ♄ ♅ ♆ ♇ ♈ ♉ ♊ ♋ ♌ ♍ ♎ ♏ ♐ ♑ ♒ ♓ ♔ ♕ ♖ ♗ ♘ ♙ ♚ ♛ ♜ ♝ ♞ ♟ ♠ ♡ ♢ ♣ ♤ ♥ ♦ ♧ ♨ ♩ ♪ ♫ ♬ ♭ ♮ ♯ ♰ ♱ ♲ ♳ ♴ ♵ ♶ ♷ ♸ ♹ ♺ ♻ ♼ ♽ ♾ ♿

MERGENTHALER LINOTYPE CO.

10-POINT CENTURY EXPANDED WITH ITALIC AND SMALL CAPS
[TWO-LETTER]

Lower case alphabet 14.06 ems

THE MOST ancient materials used for recording events were bricks, tiles, shells, and tables of stone. *The modes of writing on these different substances were various.* The tiles and brick were impressed with a stamp when in a soft state; the shells and tablets of stone were etched or graven, the figures or characters being cut in their surface, and in some cases also stained with various colors.

THE MOST ancient materials used for recording events were bricks, tiles, shells, and tables of stone. The modes of writing on these different substances were various. The tiles and brick were impressed with a stamp when in a soft state; the shells and tablets of stone were etched or graven, the figures or characters being cut in their surface, and in

ABCDEFGHIJKLMNOPQRSTUVWXYZ&
ABCDEFGHIJKLMNOPQRSTUVWXYZUN

abcdefghijklmnopqrstuvwxy
abcdefghijklmnopqrstuvwxy

1 2 3 4 5 6 7 8 9 0
V B C D E F G R T J

, . : ; ! ? (|) * ' - — . . . fi fl ff ffi ffl æ œ lb £ \$
, . S ; ! ? A I Q O ' ' - — L . . . fi Y ff W M K H lb £ P

Duplicate Character Matrices

1 2 3 4 5 6 7 8 9 0 fl ffi ffl \$ Z & : () X Z &

One-Letter Matrices

@ [] 1/8 1/4 3/8 1/2 5/8 3/4 7/8

Special set table characters. Figures and figure space .077; double figure space .154; comma, period, and quotations .0385. These sizes will be sent unless otherwise ordered.

Alignment. This face aligns with all 10-point one- and two-letter faces except German.

Will run in all machines.

To avoid errors read notice on page six

MERGENTHALER LINOTYPE CO.

12-POINT CENTURY EXPANDED WITH ITALIC AND SMALL CAPS
[TWO-LETTER]

Lower case alphabet 13.37 ems

THE MOST ancient materials employed for recording events were bricks, tiles, shells, and tables of stone. *The modes of writing on these different substances were various.* The tiles and brick were impressed with a stamp when in a soft state; the shells and tablets of stone were etched or graven, the

THE MOST ancient materials used for recording events were bricks, tiles, shells, and tablets of stone. The modes of writing on these different substances were varied. The tiles and brick were impressed with a stamp when in a soft state; the shells and tablets of stone were etched

ABCDEFGHIJKLMN OPQRSTUVWXYZ &
ABCDEFGHIJKLMN OPQRSTUVWXYZ UN

abcdefghijklmnopqrstuvwxyz
abcdefghijklmnopqrstuvwxyz

1 2 3 4 5 6 7 8 9 0

V B C D E F G R T J

, . : ; ! ? (|) * " ' — . . . fi fl ff ffi ffl æ œ lb £ \$
, . S ; ! ? AIQ O " ' — L . . . fi Y ff W M KH lb £ P

Duplicate Character Matrices.

1 2 3 4 5 6 7 8 9 0 fl ffi ffl \$ Z & : () X Z &

One-Letter Matrices

@ [] 1/8 1/4 3/8 1/2 3/4 5/8 7/8

Special set table characters. Figures and figure space .091; double figure space .182; comma, period, and quotations .0455. These sizes will be sent unless otherwise ordered.

Alignment. This face aligns with all 12-point one- and two-letter faces except German.

Will run in machines Nos. 2, 3, 4 and 5.

To avoid errors read notice on page six

SPECIMENS OF LINOTYPE FACES

12-POINT
CENTURY
EXPANDED
WITH
ITALIC AND
SMALL CAPS
Two-Letter

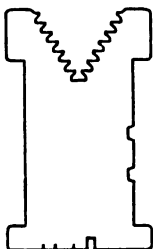

SPECIAL
CHARACTERS

Small Caps—Duplicate Character matrices.

Æ Œ

á à â ä ç é è ê ë ì í î ï ñ ó ò ô ö ú ù û ü
 á à â ä ç é è ê ë ì í î ï ñ ó ò ô ö ú ù û ü

Æ æ Œ œ “ ” ¥ £ .. ----
 Æ æ Œ œ “ ” ¥ £ L .. ----

One-Letter Matrices to be used for two-letter work.

§ ¶ || † ‡ - 1/3 2/3 1/5 2/5 3/5 4/5 1/6 5/6
 1/8 1/4 3/8 1/2 5/8 3/4 7/8 1/3 2/3 1/5 2/5 3/5 4/5 1/6 5/6

Superior: abcdefghijklmnopqrstuvwxyz abcdefghijklmnopqrstuvwxyz

Superior: 1 2 3 4 5 6 7 8 9 0

☼ ☺ ☾ ☽ ☾ ☽ ● ○ ⊕ ⊙ △ * ♀ ♀ ♂ ♂
 ♂ ♂ Ω ℘ † ≡ ∞ ♂ ♂ ♂ ♂ Π Ψ ℋ ℒ ✕
 ≡ ℏ ℓ ℓ Δ □ ∠ ≡ ≡ √ < > ± ∓ ∴ ∴ ∴ ∴
 ☛ # ' " ° " « » ™ * ™ ™ ™ % % % % ☛
 ☛ ™ ™ ™ ™ ☛

MERGENTHALER LINOTYPE CO.

12-POINT CENTURY EXPANDED WITH 10-POINT BOLD FACE NO.1
[TWO-LETTER]

Lower case alphabet 13.65 12-point and 16.38 10-point ems

The most ancient materials employed for recording events were bricks, tiles, shells, and tables of stone. The modes of writing on these different substances were various. **The most ancient materials employed for recording events were bricks, tiles, shells, and tables of stone. The modes of writing on these different substances were various.**

The most ancient materials used for recording events were bricks, tiles, shells, and tables of stone. The **The most ancient materials used for recording events were bricks, tiles, shells, and tables of stone. The**

ABCDEFGHIJKLMN OPQRSTUVWXYZ&
ABCDEFGHIJKLMN OPQRSTUVWXYZ&

abcdefghijklmnopqrstuvwxy
abcdefghijklmnopqrstuvwxy

1 2 3 4 5 6 7 8 9 0

1 2 3 4 5 6 7 8 9 0

, . : ; ! ? (|) * ' - — fi fi ff ffi ffl lb £ \$
, . : ; ! ? (|) * ' - — fi fi ff ffi ffl lb £ \$

Special set table characters. Figures and figure space .0899; double figure space .1798; comma, period, and quotations .0449. Unit system, ¼-point basis. These sizes will be sent unless otherwise ordered.

Alignment. These faces align with all 10- and 12-point faces respectively, but but do not align with each other.

Will run in machines Nos. 2, 3, 4 and 5.

To avoid errors read notice on page six

MERGENTHALER LINOTYPE CO.

6-POINT OLD STYLE NO. 1 WITH ITALIC AND SMALL CAPS [TWO-LETTER]

Lower case alphabet 15.42 ems

THE MOST ancient materials employed for recording events were bricks, tiles, shells, and tables of stone. The modes of writing on these different substances were various. The tiles and brick were impressed with a stamp when in a soft state; the shells and tablets of stone were etched or graven, the figures or characters being cut in their surface and in some cases also stained with various colors. It was by the ancient art of stamping that the walls, palaces, and towers of Babylon were covered with hieroglyphics, which have but recently been brought to light from under the immense mounds of Mesopotamia by Layard and other explorers. The patriarch Job, who is supposed to have lived about 2,300 years after the creation, exclaimed, "O that my words were now written! O that they were printed in a book! that they were graven with an iron pen and hid in the rock forever!" Stung with the unjust accusation of his friends, he desires to

THE MOST ancient materials used for recording events were bricks, tiles, shells, and tables of stone. The modes of writing on these different substances were various. The tiles and brick were impressed with a stamp when in a soft state; the shells and tablets of stone were etched or graven, the figures or characters being cut in their surface, and in some cases also stained with various colors. It was by the ancient art of stamping that the walls, palaces, and towers of Babylon were covered with hieroglyphics, which have but recently been brought to light from under the immense mounds of Mesopotamia by Layard and other explorers. The patriarch Job, who is supposed to have lived about 2,300 years after the creation, exclaimed, "O that my words were now written! O that they were printed in a book! that they were graven with an iron pen, and hid in the rock forever!" Stung with the unjust accusation

ABCDEFGHIJKLMN OPQRSTUVWXYZ &
ABCDEFGHIJKLMN OPQRSTUVWXYZ UN

abcdefghijklmnopqrstuvwxy z
abcdefghijklmnopqrstuvwxy z

1 2 3 4 5 6 7 8 9 0

V B C D E F G R T J

, . ; : ! ? (|) * ' ' - fi ff ffi ffl æ œ ð £ \$

, . ; : ! ? A I Q O ' ' - L fi Y ff W M K H ð £ P

Duplicate Character Matrices.

One-Letter Matrices.

1 2 3 4 5 6 7 8 9 0 fi ffi \$: () Z & x z * @ [] ¼ ¼ ¼ ¼ ¼ ¼ ¼

Special set table characters. Figures and figure space .050; double figure space .100; comma, period, and quotations .028. These sizes will be sent unless otherwise ordered.

Substitute table characters for use with this face can be had as follows: 6-point Old Style No. 1 Modernized figures.—Figures and figure space .050; double figure space .100. 6-point No. 12 figures with Old Style small caps.—Figures and figure space .050; double figure space .100.

Alignment. This face aligns with all 6-point one- and two-letter faces except German. Will run in all machines.

To avoid errors read notice on page six

MERGENTHALER LINOTYPE CO.

7-POINT OLD STYLE NO. 1 WITH ITALIC AND SMALL CAPS [TWO-LETTER]

Lower case alphabet 14.76 ems

THE MOST ancient materials employed for recording events were *bricks, tiles, shells, and tables of stone*. The modes of writing on these different substances were various. The tiles and brick were impressed with a stamp when in a soft state; the shells and tablets of stone were etched or graven, the figures or characters being cut in their surface, and in some cases also stained with various colors. It was by the ancient art of stamping that the walls, palaces, and towers of Babylon were covered with hieroglyphics, which have but recently been brought to light from under the immense mounds of Mesopotamia by Layard and other explorers.

THE MOST ancient materials used for recording events were bricks, tiles, shells, and tables of stone. The modes of writing on these different substances were various. The tiles and brick were impressed with a stamp when in a soft state; the shells and tablets of stone were etched or graven, the figures or characters being cut in their surface, and in some cases also stained with various colors. It was by the ancient art of stamping that the walls, palaces, and towers of Babylon were covered with hieroglyphics, which have but recently been brought to light from under the immense mounds of Mesopotamia by Layard and

ABCDEFGHIJKLMNOPQRSTUVWXYZ&
ABCDEFGHIJKLMNOPQRSTUVWXYZUN

abcdefghijklmnopqrstuvwxyz
abcdefghijklmnopqrstuvwxyzs

I 2 3 4 5 6 7 8 9 0

V B C D E F G R T J

, . : ; ! ? (|) * ' - - . . . fi ff ffi ffl æ œ ð £ \$
, . S ; ! ? A I Q O ' ' - - L . . . fi y ff w m k h ð £ P

Duplicate Character Matrices

I 2 3 4 5 6 7 8 9 0 fi ffi ffl \$ Z & : () x z &

One-Letter Matrices

@ [] ¼ ½ ¾ ⅓ ⅔ ⅜ ⅝

Special set table characters. Figures and figure space .056; double figure space .112; comma, period, and quotations .028. These sizes will be sent unless otherwise ordered.

Substitute table characters for use with this face can be had as follows: 7-point Old Style No. 1 two-letter Modernized figures.—Figures and figure space .056; double figure space .112. 7-point No. 21 figures with Old Style No. 1 small caps.—Figures and figure space .056; double figure space .112.

Alignment. This face aligns with all 7-point one- and two-letter faces except German.

Will run in all machines.

To avoid errors read notice on page six

MERGENTHALER LINOTYPE CO.

8-POINT OLD STYLE NO. 1 WITH ITALIC AND SMALL CAPS [TWO-LETTER]

Lower case alphabet 13.83 ems

THE MOST ancient materials used for recording events were bricks, tiles, shells, and tables of stone. *The modes of writing on these different substances were various.* The tiles and brick were impressed with a stamp when in a soft state; the shells and tablets of stone were etched or graven, the figures or characters being cut in their surface, and in some cases also stained with various colors. It was by the ancient art of stamping that the walls, palaces, and towers of Babylon were covered with hieroglyphics, which have but recently been brought to light from under the immense mounds of Mesopo-

THE MOST ancient materials used for recording events were bricks, tiles, shells, and tablets of stone. The modes of writing on these different substances were various. The tiles and brick were impressed with a stamp when in a soft state; the shells and tablets of stone were etched or graven, the figures or characters being cut in their surface, and in some cases also stained with various colors. It was by the ancient art of stamping that the walls, palaces, and towers of Babylon were covered with

ABCDEFGHIJKLMN OPQRSTUVWXYZ&
ABCDEFGHIJKLMN OPQRSTUVWXYZUN

abcdefghijklmnopqrstuvwxyz
abcdefghijklmnopqrstuvwxyz

I 2 3 4 5 6 7 8 9 0

V B C D E F G R T J

, . : ; ! ? (|) * ' ' - - . . . fi fl ff ffi ffl æ œ lb £ \$
, . s ; ! ? A I Q O ' ' - - L . . . fi Y ff W M K H ð £ P

Duplicate Character Matrices. One-Letter Matrices.

1234567890 fl ffi ffl \$ Z & : () x z & @ [] ¼ ¼ ¾ ½ ⅝ ¾ ⅞

True set table characters. Figures and en quad .056; em quad .112; comma, period, and quotations .028. These sizes will be sent unless otherwise ordered.

Substitute table characters for use with this face can be had as follows: 8-point Old Style No. 1 two-letter Modernized figures.—Figures and en quad .056; em quad .112. 8-point No. 4 figures with Old Style No. 1 small caps.—Figures and en quad .056; em quad .112. 8-point German No. 1 figures with Old Style No. 1 small caps.—Figures and en quad .056; em quad .112.

Alignment. This face aligns with all 8-point one- and two-letter faces having low alignment except German.
Will run in all machines.

To avoid errors read notice on page six

MERGENTHALER LINOTYPE CO.

9-POINT OLD STYLE NO. 1 WITH ITALIC AND SMALL CAPS [TWO-LETTER]

Lower case alphabet 13.23 ems

THE MOST ancient materials employed for recording events were bricks, tiles, shells, and tables of stone. *The modes of writing on these different substances were various.* The tiles and brick were impressed with a stamp when in a soft state; the shells and tablets of stone were etched or graven, the figures or characters being cut in their surface, and in some cases also stained with various colors. It was by the ancient art of stamping that the walls, palaces, and towers of Babylon were covered with hieroglyphics, which have

THE MOST ancient materials used for recording events were bricks, tiles, shells, and tables of stone. The modes of writing on these different substances were various. The tiles and brick were impressed with a stamp when in a soft state; the shells and tablets of stone were etched or graven, the figures or characters being cut in their surface, and in some cases also stained with various colors. It was by the ancient art of stamping that

ABCDEFGHIJKLMNOPQRSTUVWXYZ&
ABCDEFGHIJKLMNOPQRSTUVWXYZUN

abcdefghijklmnopqrstuvwxy
abcdefghijklmnopqrstuvwxyz

1 2 3 4 5 6 7 8 9 0

V B C D E F G R T J

, . : ; ! ? (|) * ' ' . . . ñ fl ff ffi ffl æ œ lb £ \$
. . S ; ! ? A I Q O ' ' L . . . fi Y ff W M K H th £ P

Duplicate Character Matrices

One-Letter Matrices

1 2 3 4 5 6 7 8 9 0 fl ffi ffl \$ Z & : () x z & @ [] ¼ ¾ ½ ⅓ ⅔

True set table characters. Figures and en quad .063; em quad .126; comma, period, and quotations .0315. These sizes will be sent unless otherwise ordered.

Substitute table characters for use with this face can be had as follows: 9-point Old Style No. 1 Modernized figures.—Figures and en quad .063; em quad .126. 9-point No. 13 figures with Old Style No. 1 small caps.—Figures and en quad .063; em quad .126. 9-point Old Style figures with 9-point No. 13 figures.—Figures and en quad .063; em quad .126.

Alignment. This face aligns with all 9-point one- and two-letter faces except German.

Will run in all machines.

To avoid errors read notice on page six

MERGENTHALER LINOTYPE CO.

**10-POINT OLD STYLE NO. 1 WITH ITALIC AND SMALL CAPS
[TWO-LETTER]**

Lower case alphabet 12.85 ems

THE MOST ancient materials employed for recording events were bricks, tiles, shells, and tables of stone. *The modes of writing on these different substances were various* The tiles and brick were impressed with a stamp when in a soft state; the shells and tablets of stone were etched or graven, the figures or characters being cut in their surface, and in some cases also stain-

THE MOST ancient materials used for recording events were bricks, tiles, shells, and tables of stone. The modes of writing on these different substances were various. The tiles and brick were impressed with a stamp when in a soft state; the shells and tablets of stone were etched or graven, the figures or

ABCDEFGHIJKLMNOPQRSTUVWXYZ&
ABCDEFGHIJKLMNOPQRSTUVWXYZUN

abcdefghijklmnopqrstuvwxyz
abcdefghijklmnopqrstuvwxyz

I 2 3 4 5 6 7 8 9 0
V B C D E F G R T J

, . ; ; ! ? (|) * ' ' - — . . . fi fl ff ffi ffl æ œ ð £ \$
, . S ; ! ? A I Q O ' ' - — L . . . fi Y ff W M K H ð £ P

Duplicate Character Matrices

I 2 3 4 5 6 7 8 9 0 fl ffi ffl \$ Z & : () x z &

One-Letter Matrices

@ [] 1/8 1/4 3/8 1/2 5/8 3/4 7/8

True set table characters. Figures and en quad .070; em quad .140; comma, period, and quotations .035. These sizes will be sent unless otherwise ordered.

Substitute table characters for use with this face can be had as follows: 10-point Old Style No. 1 Modernized figures.—Figures and en quad .070; em quad .140. 10-point No. 13 figures with Old Style No. 1 small caps.—Figures and en quad .070; em quad .140. 10-point Old Style No. 1 figures with Clarendon No. 1 figures.—Figures and en quad .070; em quad .140.

Alignment. This face aligns with all 10-point one- and two-letter faces except German.

Will run in all machines.

To avoid errors read notice on page six

MERGENTHALER LINOTYPE CO.

11-POINT OLD STYLE NO. 1 WITH ITALIC AND SMALL CAPS
[TWO-LETTER]

Lower case alphabet 12.27 ems

THE MOST ancient materials employed for recording events were bricks, tiles, shells, and tables of stone. *The modes of writing on these different substances were various.* The tiles and brick were impressed with a stamp when in a soft state; the shells and tablets of stone were etched or graven, the figures or characters being cut in their surface, and in some

THE MOST ancient materials used for recording events were bricks, tiles, shells, and tables of stone. The modes of writing on these different substances were various. The tiles and brick were impressed with a stamp when in a soft state; the shells and tablets of stone were etched or graven,

ABCDEFGHIJKLMN OPQRSTUVWXYZ &
ABCDEFGHIJKLMN OPQRSTUVWXYZ UN

abcdefghijklmnopqrstuvwxyz

abcdefghijklmnopqrstuvwxyz

I 2 3 4 5 6 7 8 9 0

V B C D E F G R T J

, . : ; ! ? (|) * ' ' - — . . . fi ff ffi ffl æ œ ð £ \$

, . S ; ! ? A I Q O ' ' - — L . . . fi Y ff W M K H ð £ P

Duplicate Character Matrices.

I 2 3 4 5 6 7 8 9 0 fi ffi ffl \$ Z & : () x z &

One-Letter Matrices

@ [] 1/8 1/4 3/8 1/2 5/8 3/4 7/8

True set table characters. Figures and en quad .077; em quad .154; comma, period, and quotations .0385. These sizes will be sent unless otherwise ordered.

Substitute table characters for use with this face can be had as follows: 11-point Old Style No. 1 Modernized figures.—Figures and en quad .077; em quad .154. 11-point No. 9 figures with Old Style No. 1 small caps.—Figures and en quad .077; em quad .154.

Alignment. This face aligns with all 11-point one and two-letter faces except German.

Will run in all machines.

To avoid errors read notice on page six

MERGENTHALER LINOTYPE CO.

12-POINT OLD STYLE NO. 1 WITH ITALIC AND SMALL CAPS
[TWO-LETTER]

Lower case alphabet 12.56 ems

THE MOST ancient materials used for recording events were bricks, tiles, shells, and tables of stone. *The modes of writing on these different substances were various.* The tiles and brick were impressed with a stamp when in a soft state; the shells and tablets of stone were etched or graven, the figures or characters be-

THE MOST ancient materials employed for recording events were bricks, tiles, shells, and tables of stone. The modes of writing on these different substances varied. The tiles and brick were impressed with a stamp when in a *soft state*; the

ABCDEFGHIJKLMN^{OP}QRSTU^{VW}XYZ&
ABCDEFGHIJKLMN^{OP}Q^RSTU^{VW}XY^ZUN

abcdefghijklmnopqrstuvwx^{yz}
abcdefghijklmnopqrstu^{vwxyz}

I 2 3 4 5 6 7 8 9 0

V B C D E F G R T J

, . : ; ! ? (|) * ' ' — . . . fi fl ff ffi ffl æ œ ð £ \$
, . S ; ! ? A I Q O ' ' — L . . . fi Y ff W M K H ð £ P

Duplicate Character Matrices.

I 2 3 4 5 6 7 8 9 0 fl ffi ffl \$ Z & : () x z &

One-Letter Matrices

@ [] 1/8 1/4 3/8 1/2 5/8 3/4 7/8

True set table characters. Figures and en quad .084; em quad .168; comma, period, and quotations .042. These sizes will be sent unless otherwise ordered.

Substitute table characters for use with this face can be had as follows: 12-point Old Style No. 1 Modernized figures.—Figures and en quad .084; em quad .168.

Alignment. This face aligns with all 12-point one- and two-letter faces except German.

Will run in machines Nos. 2, 3, 4 and 5.

To avoid errors read notice on page six

MERGENTHALER LINOTYPE CO.

6-POINT RONALDSON WITH ITALIC AND SMALL CAPS

[TWO-LETTER]

Lower case alphabet 15.42 ems

THE MOST ancient materials employed for recording events were bricks, tiles, shells, and tables of stone. The modes of writing on these different substances were various. The tiles and brick were impressed with a stamp when in a soft state; the shells and tablets of stone were etched or graven, the figures or characters being cut in their surface, and in some cases also stained with various colors. It was by the ancient art of stamping that the walls, palaces, and towers of Babylon were covered with hieroglyphics, which have but recently been brought to light from under the immense mounds of Mesopotamia by Layard and other explorers. The patriarch Job, who is supposed to have lived about 2,300 years after the creation, exclaimed, "O that my words were now written! O that they were printed in a book! that they were graven with an iron pen, and hid in the rock

THE MOST ancient materials employed for recording events were bricks, tiles, shells, and tables of stone. The modes of writing on these different substances were various. The tiles and brick were impressed with a stamp when in a soft state; the shells and tablets of stone were etched or graven, the figures or characters being cut in their surface, and in some cases also stained with various colors. It was by the ancient art of stamping that the walls, palaces, and towers of Babylon were covered with hieroglyphics which have but recently been brought to light from under the immense mounds of Mesopotamia by Layard and other explorers. The patriarch Job, who is supposed to have lived about 2,300 years after the creation, exclaimed, "O that my words were now written! O that they were printed in a book! that they were

ABCDEFGHIJKLMN OPQRSTUVWXYZ
ABCDEFGHIJKLMN OPQRSTUVWXYZ

abcdefghijklmnopqrstuvwxy z
abcdefghijklmnopqrstuvwxy z

1 2 3 4 5 6 7 8 9 0
V B C D E F G R T J

, ; : ! ? (|) * ' ' - fi fl ff fh fm xn ob £ \$ & Æ Œ
, ; : ! ? A I Q O ' ' - L fi Y ff W M K H th £ P & Æ Œ

Duplicate Character Matrices. One-Letter Matrices.

1 2 3 4 5 6 7 8 9 0 fi ff \$: () - & x z & @ [] ¼ ½ ¾ ⅓ ⅔

Special set table characters. Figures and figure space .050; double figure space .100; comma, period, and quotations .028. These sizes will be sent unless otherwise ordered.

Substitute table characters for use with this face can be had as follows: 6-point Ronaldson Modernized figures.—Figures and figure space .050; double figure space .100. 6-point No. 12 figures with Ronaldson small caps.—Figures and figure space .050; double figure space .100.

Alignment. This face aligns with all 6-point one- and two-letter faces except German.

Will run in all machines.

To avoid errors read notice on page six

MERGENTHALER LINOTYPE CO.

7-POINT RONALDSON WITH ITALIC AND SMALL CAPS [TWO-LETTER]

Lower case alphabet 14.76 ems

THE MOST ancient materials employed for recording events were *bricks, tiles, shells, and tables of stone*. The modes of writing on these different substances were various. The tiles and brick were impressed with a stamp when in a soft state; the shells and tablets of stone were etched or graven, the figures or characters being cut in their surface, and in some cases also stained with various colors. It was by the ancient art of stamping that the walls, palaces, and towers of Babylon were covered with hieroglyphics, which have but recently been brought to light from under the immense mounds of Mesopotamia by Layard and other explorers.

THE MOST ancient materials used for recording events were bricks, tiles, shells, and tables of stone. The modes of writing on these different substances were various. The tiles and brick were impressed with a stamp when in a soft state; the shells and tablets of stone were etched or graven, the figures or characters being cut in their surface, and in some cases also stained with various colors. It was by the ancient art of stamping that the walls, palaces, and towers of Babylon were covered with hieroglyphics, which have but recently been brought to light from under the immense mounds of Mesopotamia by Layard and

ABCDEFGHIJKLMN O P Q R S T U V W X Y Z &
ABCDEFGHIJKLMN O P Q R S T U V W X Y Z U N
abcdefghijklmnopqrstuvwxyz
abcdefghijklmnopqrstuvwxyz

1 2 3 4 5 6 7 8 9 0

V B C D E F G R T J

, . : ; ! ? (|) * ' ' - — fi ff ffi ffl æ œ ð £ \$ & Æ
, . S ; ! ? A I Q O ' ' - - L fi y ff w m k h ð £ P Æ

Duplicate Character Matrices

1 2 3 4 5 6 7 8 9 0 fi ffi \$ Z & : () x z &

One-Letter Matrices

@ [] ¼ ½ ¾ ⅓ ⅔ ⅜ ⅝

Special set table characters. Figures and figure space .056; double figure space .112; comma, period, and quotations .028. These sizes will be sent unless otherwise ordered.

Substitute table characters for use with this face can be had as follows: 7-point Ronaldson two-letter Modernized figures.—Figures and figure space .056; double figure space .112. 7-point No. 21 figures with Ronaldson small caps.—Figures and figure space .056; double figure space .112.

Alignment. This face aligns with all 7-point one- and two-letter faces except German.

Will run in all machines.

To avoid errors read notice on page six

MERGENTHALER LINOTYPE CO.

8-POINT RONALDSON WITH ITALIC AND SMALL CAPS [TWO-LETTER]

Lower case alphabet 13.83 ems

THE MOST ancient materials used for recording events were bricks, tiles, shells, and tables of stone. *The modes of writing on these different substances were various.* The tiles and brick were impressed with a stamp when in a soft state; the shells and tablets of stone were etched or graven, the figures or characters being cut in their surface, and in some cases also stained with various colors. It was by the ancient art of stamping that the walls, palaces, and towers of Babylon were covered with hieroglyphics, which have but recently been brought to light from under the immense mounds of Mesopq-

THE MOST ancient materials used for recording events were bricks, tiles, shells, and tablets of stone. The modes of writing on these different substances were various. The tiles and brick were impressed with a stamp when in a soft state; the shells and tablets of stone were etched or graven, the figures or characters being cut in their surface, and in some cases also stained with various colors. It was by the ancient art of stamping that the walls, palaces, and towers of Babylon were covered with

ABCDEFGHIJKLMNPOQRSTUVWXYZ&
ABCDEFGHIJKLMNPOQRSTUVWXYZUN

abcdefghijklmnopqrstuvwxyz
abcdefghijklmnopqrstuvwxyz

1 2 3 4 5 6 7 8 9 0

V B C D E F G R T J

, . : ; ! ? (|) * ' ' - — . . . fi fl ff ffi ffl æ œ Æ Œ th £ \$ & ©
, . S ; ! ? A I Q O ' ' - — L . . . fi y ff W M K H Æ Œ th £ P ç

Duplicate Character Matrices. One-Letter Matrices.

1234567890 fl ffi ffl \$ Z & : () x z & @ [] ¼ ¼ ¾ ½ ⅝ ¾ ⅞

True set table characters. Figures and en quad .056; em quad .112; comma, period, and quotations .028. These sizes will be sent unless otherwise ordered.

Substitute table characters for use with this face can be had as follows: 8-point Ronaldson two-letter Modernized figures.—Figures and en quad .056; em quad .112. 8-point No. 4 figures with Ronaldson small caps.—Figures and en quad .056; em quad .112. 8-point German No. 1 figures with Ronaldson small caps.—Figures and en quad .056; em quad .112.

Alignment. This face aligns with all 8-point one- and two-letter faces having low alignment except German.

Will run in all machines.

To avoid errors read notice on page six

MERGENTHALER LINOTYPE CO.

9-POINT RONALDSON WITH ITALIC AND SMALL CAPS [TWO-LETTER]

Lower case alphabet 13.23 ems

THE MOST ancient materials employed for recording events were bricks, tiles, shells, and tables of stone. *The modes of writing on these different substances were various.* The tiles and brick were impressed with a stamp when in a soft state; the shells and tablets of stone were etched or graven, the figures or characters being cut in their surface, and in some cases also stained with various colors. It was by the ancient art of stamping that the walls, palaces, and towers of Babylon were covered with hieroglyphics, which have

THE MOST ancient materials used for recording events were bricks, tiles, shells, and tables of stone. The modes of writing on these different substances were various. The tiles and brick were impressed with a stamp when in a soft state; the shells and tablets of stone were etched or graven, the figures or characters being cut in their surface, and in some cases also stained with various colors. It was by the ancient art of stamping that

ABCDEFGHIJKLMN OPQRSTUVWXYZ&
ABCDEFGHIJKLMN OPQRSTUVWXYZUN

abcdefghijklmnopqrstuvwxy z

abcdefghijklmnopqrstuvwxy z

I 2 3 4 5 6 7 8 9 0

V B C D E F G R T J

, . : ; ! ? (|) * ' ' . . . fi ff ffi ffl Æ Œ œ ð £ \$ ¢
, . S ; ! ? A I Q O ' ' L . . . fi y ff w m Æ Œ K H ð £ P ¢

Duplicate Character Matrices

One-Letter Matrices

1 2 3 4 5 6 7 8 9 0 fi ffi \$ Z & : () x z & @ [] 1/8 1/4 3/8 1/2 5/8 3/4 7/8

True set table characters. Figures and en quad .063; em quad .126; comma, period, and quotations .0315. These sizes will be sent unless otherwise ordered.

Substitute table characters for use with this face can be had as follows: 9-point Ronaldson Modernized figures.—Figures and en quad .063; em quad .126. 9-point No. 13 figures with Ronaldson small caps.—Figures and en quad .063; em quad .126.

Alignment. This face aligns with all 9-point one- and two-letter faces except German.

Will run in all machines.

To avoid errors read notice on page six

MERGENTHALER LINO TYPE CO.

10-POINT RONALDSON WITH ITALIC AND SMALL CAPS
[TWO-LETTER]

Lower case alphabet 12.85 ems

THE MOST ancient materials employed for recording events were bricks, tiles, shells, and tables of stone. *The modes of writing on these different substances were various.* The tiles and brick were impressed with a stamp when in a soft state; the shells and tablets of stone were etched or graven, the figures or characters being cut in their surface, and in some cases also stain-

THE MOST ancient materials used for recording events were bricks, tiles, shells, and tables of stone. The modes of writing on these different substances were various. The tiles and brick were impressed with a stamp when in a soft state; the shells and tablets of stone were etched or graven, the figures or

ABCDEFGHIJKLMN OPQRSTUVWXYZ &
ABCDEFGHIJKLMN OPQRSTUVWXYZ UN

abcdefghijklmnopqrstuvwxyz
abcdefghijklmnopqrstuvwxyz

1 2 3 4 5 6 7 8 9 0
V B C D E F G R T J

,.;!?(|)*'—... fi ff ffi ffl Æ Œ œ ð £ \$ &
,.S;!?AIQO'—L ... fi Y ff W M Æ Œ K H ð £ P &

Duplicate Character Matrices

1 2 3 4 5 6 7 8 9 0 fl ffi ffl \$ Z & : () x z &

One-Letter Matrices

@ [] 1/8 1/4 3/8 1/2 5/8 3/4 7/8

True set table characters. Figures and en quad .070; em quad .140; comma, period, and quotations .035. These sizes will be sent unless otherwise ordered.

Substitute table characters for use with this face can be had as follows: 10-point Ronaldson Modernized figures.—Figures and en quad .070; em quad .140. 10-point No. 13 figures with Ronaldson small caps.—Figures and en quad .070; em quad .140. 10-point Old Style No. 1 figures with Clarendon No. 1 figures.—Figures and en quad .070; em quad .140.

Alignment. This face aligns with all 10-point one- and two-letter faces except German.

Will run in all machines.

To avoid errors read notice on page six

MERGENTHALER LINOTYPE CO.

12-POINT RONALDSON WITH ITALIC AND SMALL CAPS
[TWO-LETTER]

Lower case alphabet 12.56 ems

THE MOST ancient materials used for recording events were bricks, tiles, shells, and tables of stone. *The modes of writing on these different substances were various.* The tiles and brick were impressed with a stamp when in a soft state; the shells and tablets of stone were etched or graven, the figures or characters be-

THE MOST ancient materials employed for recording events were bricks, tiles, shells, and tables of stone. The modes of writing on these different substances varied. The tiles and brick were impressed with a stamp when in a *soft state*; the

ABCDEFGHIJKLMN O P Q R S T U V W X Y Z &
ABCDEFGHIJKLMN O P Q R S T U V W X Y U N

abcdefghijklmnopqrstu vwxyz
abcdefghijklmnopqrstu vwxyz

I 2 3 4 5 6 7 8 9 0

V B C D E F G R T J

,. : ; ! ? (|) * ' — . . . fi fl ffi ffl æ œ Æ Œ th £ \$ & t
,. S ; ! ? A I Q O ' ' — L . . . fi Y ff W M K H Æ Œ th £ P & t

Duplicate Character Matrices.

I 2 3 4 5 6 7 8 9 0 fl ffi ffl \$ Z & : () X Z &

One-Letter Matrices

@ [] 1/8 1/4 3/8 1/2 5/8 3/4 7/8

True set table characters. Figures and en quad .084; em quad .168; comma, period, and quotations .042. These sizes will be sent unless otherwise ordered.

Substitute table characters for use with this face can be had as follows: 12-point Ronaldson Modernized figures.—Figures and en quad .084; em quad .168.

Alignment. This face aligns with all 12-point one- and two-letter faces except German.

Will run in machines Nos. 2, 3, 4 and 5.

To avoid errors read notice on page six

SPECIMENS OF LINOTYPE FACES

**12-POINT
RONALDSON
WITH
ITALIC AND
SMALL CAPS
Two-Letter**

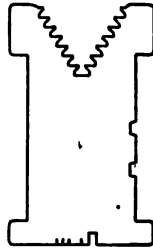

**SPECIAL
CHARACTERS**

Low Cap Accents—Regular mold may be used.

Á À Â Ã Ä Ç È É Ê Ë Ì Í Î Ï Ñ Ó Ô Õ Ö Ù Ú Û Ü
 Á À Â Ã Ä Ç È É Ê Ë Ì Í Î Ï Ñ Ó Ô Õ Ö Ù Ú Û Ü
 á à â ã ä å ç é è ê ë ì í î ï
 á à â ã ä å ç é è ê ë ì í î ï
 ñ ó ò ô õ ö ÷ ú û ü ü ü ü
 ñ ó ò ô õ ö ÷ ú û ü ü ü ü
 æ œ ï ð “ ” H £ ¥
 æ œ ï ð “ ” K £ ¥
 - -- .. ----
 L - - - L L

Duplicate Character Matrices.

Small Cap Accents.

Á À Â Ã Ä Ç È É Ê Ë Ì Í Î Ï Ñ Ó Ô Õ Ö Ù Ú Û Ü
 Æ Œ œ œ

§ ¶ || † ‡ - ¢ / + + - × × ÷ =
 1/3 2/3 1/5 2/5 3/5 4/5 1/6 5/6 1/8 1/8 1/8 1/8 1/8 1/8 1/8 1/8 1/8 1/8

Superior: abcdefghijklmnopqrstuvwxyz abcdefghijklmnopqrstuvwxyz

Superior: 1 2 3 4 5 6 7 8 9 0

☉ ☺ ☾ ☽ ☼ ☾ ☼ ☽ ☼ ☽ ☼ ☼ ☼ ☼ ☼ ☼ ☼ ☼ ☼ ☼ ☼
 ♂ ♀ ♂ ♀ ♂ ♀ ♂ ♀ ♂ ♀ ♂ ♀ ♂ ♀ ♂ ♀ ♂ ♀ ♂ ♀ ♂ ♀
 ≡ ℏ ℓ ℓ Δ □ ∠ ≡ ≡ √ < > ± ∓ ∴ ∴ ∴ ∴
 ☛ # ' " ° ' " « » ☛ * ☛ 1/100 % % % % ☛
 ☛ 111111 ☛ — — — — — ☛

MERGENTHALER LINOTYPE CO.

8-POINT OLD STYLE WITH ANTIQUE NO. 1 [TWO-LETTER]

Lower case alphabet 14.81 ems

The most ancient materials employed for recording events were bricks, tiles, shells, and tables of stone. The modes of writing on these different substances were various. The tiles and brick were impressed with a stamp when in a soft state, the shells and tablets of stone were etched or graven, the figures or characters being cut in their surface, and in some cases also stained with various colors. It was by the ancient art of stamping that the walls, palaces, and towers of Babylon were covered with hieroglyphics, which have but recently been brought to light from under the immense

The most ancient materials used for recording events were bricks, tiles, shells, and tables of stone. The modes of writing on these different substances were various. The tiles and brick were impressed with a stamp when in a soft state; the shells and tablets of stone were etched or graven, the figures or characters being cut in their surface, and in some cases also stained with various colors. It was by the ancient art of stamping that the

ABCDEFGHIJKLMN OPQRSTUVWXYZ
ABCDEFGHIJKLMN OPQRSTUVWXYZ

abcdefghijklmnopqrstu vwxyz
abcdefghijklmnopqrstu vwxyz

1 2 3 4 5 6 7 8 9 0

1 2 3 4 5 6 7 8 9 0

, . : ; ! ? (|) * ' ' - — . . . ñ ñ ñ ñ ñ ñ ñ @ £ \$ []
, . : ; ! ? (|) * ' ' - — . . . ñ ñ ñ ñ ñ ñ ñ @ £ \$ []

1/8 1/4 3/8 1/2 5/8 3/4 7/8

1/8 1/4 3/8 1/2 5/8 3/4 7/8

Special set table characters. Figures and figure space .059; double figure space .118; comma, period, and quotations .0295. These sizes will be sent unless otherwise ordered.

Substitute table characters for use with this face can be had as follows: 8-point Old Style No. 1 with Antique No. 1 Modernized figures.—Figures and figure space .059; double figure space .118. 8-point No. 4 figures with 8-point Clarendon No. 1 figures.—Figures and figure space .059; double figure space .118. 8-point Old Style No. 1 figures with 8-point Clarendon No. 1 figures.—Figures and figure space .059; double figure space .118.

Alignment. This face aligns with all 8-point one- and two-letter faces having low alignment except German.

Will run in all machines.

To avoid errors read notice on page six

MERGENTHALER LINOTYPE CO.

10-POINT OLD STYLE WITH ANTIQUE NO. 1
[TWO-LETTER]

Lower case alphabet 13.54 ems

The most ancient materials employed for recording events were bricks, tiles, shells, and tables of stone. The modes of writing on these different substances were various. The tiles and brick were impressed with a stamp when in a soft state; the shells and tablets of stone were etched or graven, the figures or characters being cut in their surface, and in some

The most ancient materials used for recording events were bricks, tiles, shells and tables of stone. The modes of writing on these different substances were various. The tiles and brick were impressed with a stamp when in a soft state; the shells and tablets of stone were etched or graven, the figures or characters being cut

ABCDEFGHIJKLMN OPQRSTUVWXYZ &
ABCDEFGHIJKLMN OPQRSTUVWXYZ &

abcdefghijklmnopqrstuvwxy z
abcdefghijklmnopqrstuvwxy z

1 2 3 4 5 6 7 8 9 0
1 2 3 4 5 6 7 8 9 0

, . : ; ! ? (|) * ' - — fi ff ffi ffl lb £ @ \$ []
, . : ; ! ? (|) * ' - — fi ff ffi ffl lb £ @ \$ []

1/8 1/4 3/8 1/2 5/8 3/4 7/8
1/8 1/4 3/8 1/2 5/8 3/4 7/8

True set table characters. Figures and en quad .070; em quad .140; comma, period, and quotations .035. These sizes will be sent unless otherwise ordered.

Substitute table characters for use with this face can be had as follows: 10-point Old Style No. 1 with Antique No. 1 Modernized figures.—Figures and en quad .070; em quad .140. 10-point No. 13 figures with Clarendon No. 1 figures.—Figures and en quad .070; em quad .140. 10-point Old Style No. 1 figures with Clarendon No. 1 figures.—Figures and en quad .070; em quad .140.

Alignment. This face aligns with all 10-point one- and two-letter faces except German.

Will run in all machines.

To avoid errors read notice on page six

MERGENTHALER LINOTYPE CO.

11-POINT OLD STYLE WITH ANTIQUE NO. 1
[TWO-LETTER]

Lower case alphabet 13.14 ems

The most ancient materials employed for recording events were bricks, tiles, shells, and tables of stone. The modes of writing on these different substances were various. The tiles and brick were impressed with a stamp when in a soft state; the shells and tablets of stone were etched or graven, the figures or characters being cut in

The most ancient materials used for recording events were bricks, tiles, shells, and tables of stone. The tiles and brick were impressed with a stamp when in a soft state; the shells and tablets of stone were etched or graven, the figures or characters being cut in their surface,

ABCDEFGHIJKLMN^OPQRSTUVWXYZ&
ABCDEFGHIJKLMN^OPQRSTUVWXYZ&

abcdefghijklmnopqrstu^vwxyz
abcdefghijklmnopqrstu^vwxyz

1 2 3 4 5 6 7 8 9 0

1 2 3 4 5 6 7 8 9 0

, . : ; ! ? (|) * ' - — fi ff ffi ffl tt @ £ \$ []
, . : ; ! ? (|) * ' - — fi ff ffi ffl tt @ £ \$ []

$\frac{1}{8}$ $\frac{1}{4}$ $\frac{3}{8}$ $\frac{1}{2}$ $\frac{5}{8}$ $\frac{3}{4}$ $\frac{7}{8}$
 $\frac{1}{8}$ $\frac{1}{4}$ $\frac{3}{8}$ $\frac{1}{2}$ $\frac{5}{8}$ $\frac{3}{4}$ $\frac{7}{8}$

True set table characters. Figures and en quad .077; em quad .154; comma, period, and quotations .0385. These sizes will be sent unless otherwise ordered.

Substitute table characters for use with this face can be had as follows: 11-point Old Style No. 1 with Antique No. 1 Modernized figures.—Figures and en quad .077; em quad .154. 11-point No. 9 figures with Clarendon No. 1 figures.—Figures and en quad .077; em quad .154.

Alignment. This face aligns with all 11-point one and two-letter faces except German.

Will run in all machines.

To avoid errors read notice on page six

MERGENTHALER LINOTYPE CO.

12-POINT OLD STYLE WITH ANTIQUE NO. 1 [TWO-LETTER]

Lower case alphabet 13.29 ems

The most ancient materials employed for recording events were bricks, tiles, shells, and tables of stone. The modes of writing on these different substances were various. The tiles and brick were impressed with a stamp when in a soft state; the shells and

The most ancient materials used for recording events were bricks, tiles, shells, and tables of stone. The modes of writing on these different substances were various. The tiles and brick were impressed with a stamp when

ABCDEFGHIJKLMN^oOPQRSTUVWXYZ&
ABCDEFGHIJKLMN^oOPQRSTUVWXYZ&

abcdefghijklmnopqrstu^vvwxyz
abcdefghijklmnopqrstu^vvwxyz

1 2 3 4 5 6 7 8 9 0
1 2 3 4 5 6 7 8 9 0

, . : ; ! ? (|) * ' ' — fi fl ff ffi ffl lb £ \$
, . : ; ! ? (|) * ' ' — fi fl ff ffi ffl lb £ \$

@ [] 1/8 1/4 3/8 1/2 5/8 3/4 7/8
@ [] 1/8 1/4 3/8 1/2 5/8 3/4 7/8

True set table characters. Figures and en quad .084; em quad .168; comma, period, and quotations .042. These sizes will be sent unless otherwise ordered.

Substitute table characters for use with this face can be had as follows: 12-point Old Style No. 1 with Antique No. 1 Modernized figures.— Figures and en quad .084; em quad .168.

Alignment. This face aligns with all 12-point one- and two-letter faces except German.

Will run in machines Nos. 2, 3, 4 and 5.

To avoid errors read notice on page six

MERGENTHALER LINOTYPE CO.

6-POINT RONALDSON WITH ANTIQUE NO. 1 [TWO-LETTER]

Lower case alphabet 15.71 ems

The most ancient materials employed for recording events were bricks, tiles, shells, and tables of stone. The modes of writing on these different substances were various. The tiles and brick were impressed with a stamp when in a soft state; the shells and tablets of stone were etched or graven, the figures or characters being cut in their surface, and in some cases also stained with various colors. It was by the ancient art of stamping that the walls, palaces, and towers of Babylon were covered with hieroglyphics, which have but recently been brought to light from under the immense mounds of Mesopotamia by Layard and other explorers. The patriarch Job, who is supposed to have lived about 2,300 years after the creation, exclaimed, "O that my words were now written! O that they were printed in a book! that they were graven with an iron pen, and hid in the rock forever!" Stung with the unjust accusation of his friends, he desires to record his words that the generations

The most ancient materials used for recording events were bricks, tiles, shells, and tables of stone. The modes of writing on these different substances were various. The tiles and brick were impressed with a stamp when in a soft state; the shells and tablets of stone were etched or graven, the figures or characters being cut in their surface, and in some cases also stained with various colors. It was by the ancient art of stamping that the walls, palaces, and towers of Babylon were covered with hieroglyphics, which have but recently been brought to light from under the immense mounds of Mesopotamia by Layard and other explorers. The patriarch Job, who is supposed to have lived about 2,300 years after the creation, exclaimed, "O that my words were now written! O that they were printed in a book! that they

ABCDEFGHIJKLMNOPQRSTUVWXYZ&
ABCDEFGHIJKLMNOPQRSTUVWXYZ&

abcdefghijklmnopqrstuvwxyz
abcdefghijklmnopqrstuvwxyz

1 2 3 4 5 6 7 8 9 0
1 2 3 4 5 6 7 8 9 0

, . : ; ! ? () * ' ' - ñ ñ ñ ñ ñ ñ @ £ \$ []
, . : ; ! ? () * ' ' - ñ ñ ñ ñ ñ ñ @ £ \$ []
¼ ¼ ¼ ¼ ¼ ¼ ¼
¾ ¾ ¾ ¾ ¾ ¾ ¾

Special set table characters. Figure and figure space .050; double figure space .100; comma, period, and quotations .028. These sizes will be sent unless otherwise ordered.

Substitute table characters for use with this face can be had as follows: 6-point Old Style with Antique Modernized figures.—Figures and figure space .050; double figure space .100.

Alignment: This face aligns with all 6-point one- and two-letter faces except German.

Will run in all machines

To avoid errors read notice on page six

MERGENTHALER LINOTYPE CO.

8-POINT RONALDSON WITH ANTIQUE NO.1 [TWO-LETTER]

Lower case alphabet 14.81 ems

The most ancient materials employed for recording events were bricks, tiles, shells, and tables of stone. The modes of writing on these different substances were various. The tiles and brick were impressed with a stamp when in a soft state, the shells and tablets of stone were etched or graven, the figures or characters being cut in their surface, and in some cases also stained with various colors. It was by the ancient art of stamping that the walls, palaces, and towers of Babylon were covered with hieroglyphics, which have but recently been brought to light from under the immense

The most ancient materials used for recording events were bricks, tiles, shells, and tables of stone. The modes of writing on these different substances were various. The tiles and brick were impressed with a stamp when in a soft state; the shells and tablets of stone were etched or graven, the figures or characters being cut in their surface, and in some cases also stained with various colors. It was by the ancient art of stamping that the walls, palaces, and towers of Babylon

ABCDEFGHIJKLMN OPQRSTUVWXYZ&
ABCDEFGHIJKLMN OPQRSTUVWXYZ&
abcdefghijklmnopqrstuvwxy z

1 2 3 4 5 6 7 8 9 0

1 2 3 4 5 6 7 8 9 0

.,.;!?(|)*''-... fl ff m m th @ £ \$ [] Æ Œ & t

.,.;!?(|)*''-... fl ff m m th @ £ \$ [] Æ Œ

1/8 1/4 3/8 1/2 5/8 3/4 7/8

1/8 1/4 3/8 1/2 5/8 3/4 7/8

Special set table characters. Figures and figure space .059; double figure space .118; comma, period, and quotations .0295. These sizes will be sent unless otherwise ordered.

Substitute table characters for use with this face can be had as follows:
8-point Ronaldson with Antique No. 1 Modernized figures.—Figures and figure space .059; double figure space .118.

Alignment. This face aligns with all 8-point one- and two-letter faces having low alignment except German.

Will run in all machines.

To avoid errors read notice on page six

MERGENTHALER LINOTYPE CO.

11-POINT RONALDSON WITH ANTIQUE NO. 1
[TWO-LETTER]

Lower case alphabet 13.14 ems

The most ancient materials employed for recording events were bricks, tiles, shells, and tables of stone. The modes of writing on these different substances were various. The tiles and brick were impressed with a stamp when in a soft state; the shells and tablets of stone were etched or graven, the figures or characters being cut in

The most ancient materials used for recording events were bricks, tiles, shells, and tables of stone. The tiles and brick were impressed with a stamp when in a soft state; the shells and tablets of stone were etched or graven, the figures or characters being cut in their surface,

ABCDEFGHIJKLMNPOQRSTUVWXYZ&
ABCDEFGHIJKLMNPOQRSTUVWXYZ&

abcdefghijklmnopqrstuvwxy
abcdefghijklmnopqrstuvwxy

1 2 3 4 5 6 7 8 9 0
1 2 3 4 5 6 7 8 9 0

, . : ; ! ? (|) * ' " - — fi fl ff fh fi ll lb £ \$
, . : ; ! ? (|) * ' " - — fi fl ff fh fi ll lb £ \$

Æ Œ ct @ [] 1/8 1/4 3/8 1/2 5/8 3/4 7/8
Æ Œ @ [] 1/8 1/4 3/8 1/2 5/8 3/4 7/8

True set table characters. Figures and en quad .077; em quad .154; comma, period, and quotations .0385. These sizes will be sent unless otherwise ordered.

Substitute table characters for use with this face can be had as follows: 11-point Old Style No. 1 with Antique No. 1 Modernized figures.—Figures and en quad .077; em quad .154. 11-point No. 9 figures with Clarendon No. 1 figures.—Figures and en quad .077; em quad .154.

Alignment. This face aligns with all 11-point one and two-letter faces except German.
Will run in all machines.

To avoid errors read notice on page six

MERGENTHALER LINOTYPE CO.

12-POINT RONALDSON WITH ANTIQUE NO. 1

[TWO-LETTER]

Lower case alphabet 13.29 ems

The most ancient materials employed for recording events were bricks, tiles, shells, and tables of stone. The modes of writing on these different substances were various. The tiles and brick were impressed with a stamp when in a soft state; the shells and tablets of stone were etched or graven, the

The most ancient materials used for recording events were bricks, tiles, shells, and tables of stone. The modes of writing on these different substances were varied. The tiles and brick were impressed with a stamp when

ABCDEFGHIJKLMNOPQRSTUVWXYZ&
ABCDEFGHIJKLMNOPQRSTUVWXYZ&

abcdefghijklmnopqrstuvwxy
abcdefghijklmnopqrstuvwxy

1 2 3 4 5 6 7 8 9 0

1 2 3 4 5 6 7 8 9 0

, . ; ! ? (|) * ' - — . . . fi fl ff ffi ffl lb £ \$
, . ; ! ? (|) * ' - — . . . fi fl ff ffi ffl lb £ \$

Æ Œ & @ [] 1/8 1/4 3/8 1/2 5/8 3/4 7/8
Æ Œ @ [] 1/8 1/4 3/8 1/2 5/8 3/4 7/8

True set table characters. Figures and en quad .084; em quad .168; comma, period, and quotations .042. These sizes will be sent unless otherwise ordered.

Substitute table characters for use with this face can be had as follows: 12-point Old Style No. 1 with Antique No. 1 Modernized figures.— Figures and en quad .084; em quad .168.

Alignment. This face aligns with all 12-point one- and two-letter faces except German.

Will run in machines Nos. 2, 3, 4 and 5.

To avoid errors read notice on page six

MERGENTHALER LINOTYPE CO.

8-POINT CAMBRIDGE WITH ITALIC AND SMALL CAPS [TWO-LETTER]

Lower case alphabet 12.96 ems

THE MOST ancient materials employed for recording events were bricks, tiles, shells, and tables of stone. *The modes of writing on these different substances were various.* The tiles and brick were impressed with a stamp when in a soft state; the shells and tablets of stone were etched or graven, the figures or characters being cut in their surface, and in some cases also stained with various colors. It was by the ancient art of stamping that the walls, palaces, and towers of Babylon were covered with hieroglyphics, which have but recently been brought to light from under the immense mounds of Mesopotamia by Layard and other

THE MOST ancient materials employed for recording events were bricks, tiles, shells, and tables of stone. The modes of writing on these different substances were various. The tiles and brick were impressed with a stamp when in a soft state; the shells and tablets of stone were etched or graven, the figures or characters being cut in their surface, and in some cases also stained with various colors. It was by the ancient art of stamping that the walls, palaces, and towers of Babylon were covered with hieroglyphics, which have but recently

ABCDEFGHIJKLMNOPQRSTUVWXYZ&
ABCDEFGHIJKLMNOPQRSTUVWXYZUN

abcdefghijklmnopqrstuvwxyz

abcdefghijklmnopqrstuvwxyz

I 2 3 4 5 6 7 8 9 0

V B C D E F G R T J

, . : ; ! ? (|) * ' - fi fl ff ffi ffi æ œ lb £ \$
, . s ; ! ? A I Q O ' ' - - L fi Y ff W M K H B £ P

Duplicate Character Matrices

1 2 3 4 5 6 7 8 9 0 \$ Z & : () x z &

One-Letter Matrices

@ [] 1/8 1/4 3/8 1/2 5/8 3/4 7/8

True set table characters. Figures and en quad .0553; em quad .1107; comma, period, and quotations .0277. Unit system, 1/4-point basis. These sizes will be sent unless otherwise ordered.

Substitute table characters for use with this face can be had as follows: 8-point Cambridge Modernized figures.—Figures and en quad .0553; em quad .1107.

Alignment. This face aligns with all 8-point one- and two-letter faces having low alignment except German. Will run in all machines.

To avoid errors read notice on page six

MERGENTHALER LINOTYPE CO.

10-POINT CAMBRIDGE WITH ITALIC AND SMALL CAPS
[TWO-LETTER]

Lower case alphabet 12.12 ems

THE MOST ancient materials used for recording events were brick, tiles, shells, and tables of stone. *The modes of writing on these different substances were various.* The tiles and brick were impressed with a stamp when in a soft state; the shells and tablets of stone were etched or graven, the figures or characters being cut in their surface, and in some cases also stained with various colors. It was by the ancient art of stamping that the walls, pal-

THE MOST ancient materials used for recording events were bricks, tiles, shells, and tables of stone. *The modes of writing on these different substances were various.* The tiles and brick were impressed with a stamp when in a soft state; the shells and tablets of stone were etched or graven, the figures or characters being cut in their surface, and in some cases also stained with various colors. It

ABCDEFGHIJKLMN OPQRSTUVWXYZ&
ABCDEFGHIJKLMN OPQRSTUVWXYZ
abcdefghijklmnopqrstu vwxyz
abcdefghijklmnopqrstu vwxyz

1 2 3 4 5 6 7 8 9 0

V B C D E F G R T J

, . : ; ! ? (|) * ' ' - — . . . fi ff ffi ffl æ œ ð £ \$
, . S ; ! ? A I Q O ' ' - — L . . . fi Y ff W M K H ð £ P

Duplicate Character Matrices

I 2 3 4 5 6 7 8 9 0 fl ffi ffl \$ Z & : () x z &

One-Letter Matrices

@ [] 1/8 1/4 3/8 1/2 5/8 3/4 7/8

True set table characters. Figures and en quad .0691; em quad .1383; comma, period, and quotations .0346. Type foundry's point system. These sizes will be sent unless otherwise ordered.

Alignment. This face aligns with all 10-point one- and two-letter faces except German.

Will run in all machines.

To avoid errors read notice on page six

MERGENTHALER LINOTYPE CO.

11-POINT CAMBRIDGE WITH ITALIC AND SMALL CAPS
[TWO-LETTER]

Lower case alphabet 12.26 ems

THE MOST ancient materials employed for recording events were bricks, tiles, shells, and tables of stone. *The modes of writing on these different substances were various.* The tiles and brick were impressed with a stamp when in a soft state; the shells and tablets of stone were etched or graven, the figures or characters being cut in their surface, and in some cases also stained with various colors.

THE MOST ancient materials used for recording events were bricks, tiles, shells, and tables of stone. *The modes of writing on these different substances were various.* The tiles and brick were impressed with a stamp when in a soft state; the shells and tablets of stone were etched or graven, the figures or characters being cut in

ABCDEFGHIJKLMN OPQRSTUVWXYZ
ABCDEFGHIJKLMN OPQRSTUVWXYZUN

abcdefghijklmnopqrstuvwxy
abcdefghijklmnopqrstuvwxyz

I 2 3 4 5 6 7 8 9 0
V B C D E F G R T J

, . : ; ! ? (|) * ' ' — . . . fi fl ff ffi ffl æ œ ð £ \$
, . S ; ! ? AI Q O ' ' — L . . . fi Y ff W M K H ð £ P

Duplicate Character Matrices.

I 2 3 4 5 6 7 8 9 0 fl ffi ffl Z & \$: () X Z &

One-Letter Matrices

@ [] 1/8 1/4 3/8 1/2 5/8 3/4 7/8

True set table characters. Figures and en quad .0761; em quad .1522; comma, period and quotations .038. Unit system, 1/4-point basis.

These sizes will be sent unless otherwise ordered.

Alignment. This face aligns with all 11-point one- and two-letter faces except German.

Will run in all machines.

To avoid errors read notice on page six

MERGENTHALER LINOTYPE CO.

10-POINT FRENCH OLD STYLE WITH ITALIC AND SMALL CAPS
[TWO-LETTER]

Lower case alphabet 11.81 ems

THE MOST ancient materials employed for recording events were bricks, tiles, shells, and tables of stone. *The modes of writing on these different substances were various.* The tiles and brick were impressed with a stamp when in a soft state; the shells and tablets of stone were etched or graven, the figures or characters being cut in their surface, and in some cases also stained with various colors. It was by the ancient art of stamping that the walls, palaces, and towers of Baby-

THE MOST ancient materials used for recording events were bricks, tiles, shells, and tables of stone. The modes of writing on these different substances were various. The tiles and brick were impressed with a stamp when in a soft state; the shells and tablets of stone were etched or graven, the figures or characters being cut in their surface, and in some cases also stained

ABCDEFGHIJKLMN O PQRSTU VWXYZ &
ABCDEFGHIJKLMN O PQRSTU VWXYUN

abcdefghijklmnopqrstuvwxy
abcdefghijklmnopqrstuvwxy

1 2 3 4 5 6 7 8 9 0
V B C D E F G R T J

, . : ; ! ? * ' ' (|) - — . . . fi fl ff ffi ffl æ œ ð £ \$
, . S ; ! ? O ' ' A I Q - — L . . . fi Y ff W M K H ð £ P

Duplicate Character Matrices.

1 2 3 4 5 6 7 8 9 0 ß ffi ffl \$ Z & : () x l &
One-Letter Matrices

@ [] 1/8 1/4 3/8 1/2 5/8 3/4 7/8

True set table characters. Figures and en quad .0691; em quad .1383; comma, period, and quotations .0346. Unit system, 1/4-point basis. These sizes will be sent unless otherwise ordered.

Substitute table characters for use with this face can be had as follows: 10-point French Old Style Modernized figures.—Figures and en quad .0691; em quad .1383.

Alignment. This face aligns with all 10-point one- and two-letter faces except German.

Will run in all machines.

To avoid errors read notice on page six

MERGENTHALER LINOTYPE CO.

10-POINT ORIGINAL OLD STYLE WITH ITALIC AND SMALL CAPS
[TWO-LETTER]

Lower case alphabet 12.29 ems

THE MOST ancient materials employed for recording events were bricks, tiles, shells, and tables of stone. *The modes of writing on these different substances were various.* The tiles and brick were impressed with a stamp when in a soft state; the shells and tablets of stone were etched or graven, the figures or characters being cut in their surface, and in some cases also stained with various colors. It was by the ancient art of stamping that the

THE MOST ancient materials used for recording events were bricks, tiles shells, and tablets of stone. The modes of writing on these different substances were various. The tiles and brick were impressed with a stamp when in a soft state; the shells and tablets of stone were etched or graven, the figures or characters being cut in their surface, and in some

ABCDEFGHIJKLMN~~OP~~QRSTU~~VW~~XYZ&
ABCDEFGHIJKL~~MNOP~~QRSTU~~VW~~XYUN

abcdefghijklmnopqrstuvwxy~~z~~
abcdefghijklmnopqrstuvwxy~~z~~

1 2 3 4 5 6 7 8 9 0
V B C D E F G R T J

, . : ; ! ? (|) * ' ' - — . . . fi fl ff ffi ffl æ œ ð £ \$
, . s ; ! ? A I Q O ' ' - — L . . . fi Y ff W M K H ð £ P

Duplicate Character Matrices.

1 2 3 4 5 6 7 8 9 0 fl ffi ffl \$ Z € : () x z &

One-Letter Matrices

@ [] 1/8 1/4 3/8 1/2 5/8 3/4 7/8

True set table characters. Figures and en quad .0691; em quad .1383; comma, period, and quotations .0346. Type founders' point system. These sizes will be sent unless otherwise ordered.

Substitute table characters for use with this face can be had as follows: 10-point Original Old Style Modernized figures. Sizes same as the Old Style figures given above.

Alignment. This face aligns with all 10-point one- and two-letter faces except German.

Will run in all machines.

To avoid errors read notice on page six

MERGENTHALER LINOTYPE CO.

12-POINT ORIGINAL OLD STYLE WITH ITALIC AND SMALL CAPS
 [TWO-LETTER]

Lower case alphabet 11.83 ems

THE MOST ancient materials used for recording events were bricks, tiles, shells, and tables of stone. *The modes of writing on these different substances were various.* The tiles and brick were impressed with a stamp when in a soft state; the shells and tablets of stone were etched or graven, the figures or characters being cut in their surface, and in

THE MOST ancient materials used for recording events were bricks, tiles, shells, and tables of stone. The modes of writing on these different substances were varied. The tiles and brick were impressed with a stamp when in a soft state; the shells and tab-

ABCDEFGHIJKLMN**OP**QRSTU**VW**XYZ&
 ABCDEFGHIJKLMN**OP**QRSTU**VW**XYUN

abcdefghijklmnopqrstuvwxy
 abcdefghijklmnopqrstuvwxy

1 2 3 4 5 6 7 8 9 0

V B C D E F G R T J

, . ; ! ? (|) * ' ' — . . . fi fl ff ffi ffl æ œ lb £ \$
 , . S ; ! ? A I Q O ' ' — L . . . fi Y ff W M K H th £ P

Duplicate Character Matrices.

1 2 3 4 5 6 7 8 9 0 fl ffi ffl \$ Z & : () x z &

One-Letter Matrices

@ [] 1/8 1/4 3/8 1/2 5/8 3/4 7/8

True set table characters. Figures and en quad .084; em quad .168; comma, period, and quotations .042. These sizes will be sent unless otherwise ordered.

Substitute table characters for use with this face can be had as follows: 12-point Original Old Style Modernized figures.

Alignment. This face aligns with all 12-point one- and two-letter faces except German.

Will run in machines Nos. 2, 3, 4 and 5.

To avoid errors read notice on page six

MERGENTHALER LINOTYPE CO.

14-POINT ORIGINAL OLD STYLE WITH ITALIC AND SMALL CAPS
[TWO-LETTER]

Lower case alphabet 12.14 ems

THE MOST ancient materials employed for recording events were bricks, tiles, shells, and tables of stone. *The modes of writing on these different substances were various.* The tiles and brick were impressed with a stamp when in a soft state;

THE MATERIALS most used in early days for recording events were bricks, tiles, shells, and tables of stone. The modes of writing on these different substances

ABCDEFGHIJKLMN OPQRSTUVWXYZ
ABCDEFGHIJKL MNOPQRST UVWXYZ UN

abcdefghijklmnopqrstuvwxy z
abcdefghijklmnopqrstuvwxy z

1 2 3 4 5 6 7 8 9 0

V B C D E F G R T J

, . : ; ? ! () * ' ' - — fi fl ff ffi ffl æ œ ß £ \$

, . s ; ? ! AIQO ' ' - — L fi Y ff W M K H ß £ P

In Auxiliary Position.

1 2 3 4 5 6 7 8 9 0 fl ffi ffl Z & \$: () x z &

One-Letter Matrices

@ [] 1/8 1/4 3/8 1/2 5/8 3/4 7/8

True set table characters. Figures and en quad .0968; em quad .1936; comma, period, and quotations .0484. Unit system, 1/2-point basis. These sizes will be sent unless otherwise ordered.

Substitute table characters for use with this face can be had as follows: 14-point Original Old Style Modernized figures.

Alignment. This face aligns with all 14-point one- and two-letter faces except German.

Will run in machines Nos. 2, 3, 4 and 5.

To avoid errors read notice on page six

SPECIMENS OF LINOTYPE FACES

**14-POINT
ORIGINAL
OLD STYLE
WITH
ITALIC AND
SMALL CAPS
Two-Letter**

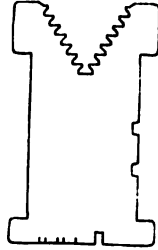

**CHARACTERS
SPECIAL**

á à â ä ç é è ê ë ì í î ï ñ ó ô õ ö ú û ü
á à â ä ç é è ê ë ì í î ï ñ ó ô õ ö ú û ü

Æ æ Œ œ
Æ æ Œ œ

In Auxillary Position.

Æ Œ

One-Letter Matrices to be used for two-letter work.

§ ¶ || † ‡ - /

$\frac{1}{3}$ $\frac{2}{3}$ $\frac{1}{5}$ $\frac{2}{5}$ $\frac{3}{5}$ $\frac{4}{5}$ $\frac{1}{6}$ $\frac{5}{6}$

$\frac{1}{8}$ $\frac{1}{4}$ $\frac{3}{8}$ $\frac{1}{2}$ $\frac{5}{8}$ $\frac{3}{4}$ $\frac{7}{8}$ $\frac{1}{3}$ $\frac{2}{3}$ $\frac{1}{5}$ $\frac{2}{5}$ $\frac{3}{5}$ $\frac{4}{5}$ $\frac{1}{6}$ $\frac{5}{6}$



MERGENTHAUER LINOTYPE CO.

8-POINT SCOTCH WITH ITALIC AND SMALL CAPS [TWO-LETTER]

Lower case alphabet 13.73 ems

THE MOST ancient materials employed for recording events were bricks, tiles, shells, and tables of stone. *The modes of writing on these different substances were various.* The tiles and brick were impressed with a stamp when in a soft state; the shells and tablets of stone were etched or graven, the figures or characters being cut in their surface, and in some cases also stained with various colors. It was by the ancient art of stamping that the walls, palaces, and towers of Babylon were covered with hieroglyphics, which have but recently been brought to light from under the immense mounds of Mesopotamia by Layard and other explorers. The patriarch Job, who

THE MOST ancient materials employed for recording events were bricks, tiles, shells, and tables of stone. The modes of writing on these different substances were various. The tiles and brick were impressed with a stamp when in a soft state; the shells and tablets of stone were etched or graven, the figures or characters being cut in their surface, and in some cases also stained with various colors. It was by the ancient art of stamping that the walls, palaces, and towers of Babylon were cov-

ABCDEFGHIJKLMN O PQRSTU VWXYZ&
ABCDEFGHIJKLMN O PQRSTU VWXYUN

abcdefghijklmnopqrstuvwxy
abcdefghijklmnopqrstvwxyz

, . : ; ! ? (|) * ' ' — . . . fi fl ff ffi ffl æ œ ð £ \$
, . s ; ! ? A I Q O ' ' — L . . . ſ ŷ ff w m k h ð £ P

Duplicate Character Matrices.

1 2 3 4 5 6 7 8 9 0 ſ ſ ſ ſ Z & : () x z &

One-Letter Matrices

@ [] 1/8 1/4 3/8 1/2 5/8 3/4 7/8

True set table characters. Figures and en quad .056; em quad .112; comma, period, and quotations .028. These sizes will be sent unless otherwise ordered.

Substitute table characters for use with this face can be had as follows: 8-point No. 19 with Title No. 1 Modernized figures.—Figures and en quad .056; em quad .112.

Alignment. This face aligns with all 8-point one- and two-letter faces having high alignment except German.

Will run in all machines.

To avoid errors read notice on page six

MERGENTHALER LINOTYPE CO.

10-POINT SCOTCH WITH ITALIC AND SMALL CAPS
[TWO-LETTER]

Lower case alphabet 12.35 ems

THE MOST ancient materials employed for recording events were bricks, tiles, shells, and tables of stone. *The modes of writing on these different substances were various.* The tiles and brick were impressed with a stamp when in a soft state; the shells and tablets of stone were etched or graven, the figures or characters being cut in their surface, and in some cases also stained with various colors. It was by the ancient art of stamping that the walls, palaces, and towers of Babylon were covered with

THE MOST ancient materials used for recording events were bricks, tiles, shells, and tables of stone. The modes of writing on these different substances were various. The tiles and brick were impressed with a stamp when in a soft state; the shells and tablets of stone were etched or graven, the figures or characters being cut in their surface, and in some

ABCDEFGHIJKLMN OPQRSTUVWXYZ &
ABCDEFGHIJKLMN OPQRSTUVWXYZ_{UN}

abcdefghijklmnopqrstuvwxyz

abcdefghijklmnopqrstuvwxyz

1 2 3 4 5 6 7 8 9 0

V B C D E F G R T J

, . : ; ! ? (|) * ' ' - — fi fl ff ffi ffl æ œ ð £ \$

, . s ; ! ? A I Q O ' ' - — L fi Y ff W M K H ð £ P

Duplicate Character Matrices.

1 2 3 4 5 6 7 8 9 0 fl ffi ffl \$ Z & : () x z &

One-Letter Matrices

@ [] 1/8 1/4 3/8 1/2 5/8 3/4 7/8

True set table characters. Figures and en quad .070; em quad .140; comma, period, and quotations .035. These sizes will be sent unless otherwise ordered.

Alignment. This face aligns with all 10-point one- and two-letter faces except German.

Will run in all machines.

To avoid errors read notice on page six

MERGENTHALER LINOTYPE CO.

11-POINT SCOTCH WITH ITALIC AND SMALL CAPS
[TWO-LETTER]

Lower case alphabet 12.11 ems

THE MOST ancient materials employed for recording events were bricks, tiles, shells, and tables of stone. *The modes of writing on these different substances were various.* The tiles and brick were impressed with a stamp when in a soft state; the shells and tablets of stone were etched or graven, the figures or characters being cut in their surface, and in some cases also stained with various colors. It was by the ancient art

THE MOST ancient materials used for recording events were bricks, tiles, shells, and tables of stone. The modes of writing on these different substances were various. The tiles and brick were impressed with a stamp when in a soft state; the shells and tablets of stone were etched or graven, the figures or characters being cut in their sur-

ABCDEFGHIJKLMN OPQRSTUVWXYZ &
ABCDEFGHIJKLMN OPQRSTUVWXYZ UN

abcdefghijklmnopqrstuvwxyz
abcdefghijklmnopqrstuvwxyz

1 2 3 4 5 6 7 8 9 0

V B C D E F G R T J

, . : ; ! ? (|) * ' ' - — . . . fi fl ff ffi ffl æ œ ð £ \$
, . s ; ! ? A I Q O ' ' - — L . . . fi Y ff w m k h ð £ P

Duplicate Character Matrices.

1 2 3 4 5 6 7 8 9 0 fl ffi ffl Z & \$: () x z &

One-Letter Matrices

@ [] 1/8 1/4 3/8 1/2 5/8 3/4 7/8

True set table characters. Figures and en quad .077; em quad .154; comma, period and quotations .0385. These sizes will be sent unless otherwise ordered.

Alignment. This face aligns with all 11-point one- and two-letter faces except German.

Will run in all machines.

To avoid errors read notice on page six

MERGENTHALER LINOTYPE CO.

12-POINT SCOTCH WITH ITALIC AND SMALL CAPS
[TWO-LETTER]

Lower case alphabet 12.83 ems

THE MOST ancient materials employed for recording events were bricks, tiles, shells, and tables of stone. *The modes of writing on these different substances were various.* The tiles and brick were impressed with a stamp when in a soft state; the shells and tablets of stone were etched or graven, the figures or characters

THE MOST ancient materials used for recording events were bricks, tiles, shells, and tables of stone. The modes of writing on these different articles varied. The bricks and tiles were impressed with a stamp when in a *soft state*; the shells and tables of stone were etched

ABCDEFGHIJKLMN OPQRSTUVWXYZ &
ABCDEFGHIJKLMN OPQRSTUVWXYZ UN

abcdefghijklmnopqrstuvwxy
abcdefghijklmnopqrstuvwxyz

1 2 3 4 5 6 7 8 9 0

V B C D E F G R T J

, . : ; ! ? (|) * ' ' — . . . fi fl ff ffi ffl æ œ ð £ \$
, . s ; ! ? A I Q O ' ' — L . . . fi Y ff W M K H ð £ P

Duplicate Character Matrices.

1 2 3 4 5 6 7 8 9 0 fi ffi ffl \$ Z & : () x z &

One-Letter Matrices

@ [] 1/8 1/4 3/8 1/2 5/8 3/4 7/8

True set table characters. Figures and en quad .084; em quad .168; comma, period, and quotations .042. These sizes will be sent unless otherwise ordered.

Alignment. This face aligns with all 12-point one- and two-letter faces except German.

Will run in machines Nos. 2, 3, 4 and 5.

To avoid errors read notice on page six

SPECIMENS OF LINOTYPE FACES

**12-POINT
SCOTCH
WITH
ITALIC AND
SMALL CAPS
Two-Letter**

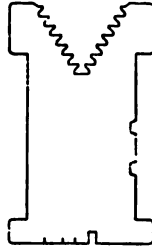

**SPECIAL
CHARACTERS**

Low Cap Accents—Regular mold may be used.

À Á Â Ã Ä Ç È É Ê Ë Ì Í Î Ï Ñ Ó Ô Õ Ö Ù Ú Û Ü
À Á Â Ã Ä Ç È É Ê Ë Ì Í Î Ï Ñ Ó Ô Õ Ö Ù Ú Û Ü

Small Cap Accents—Duplicate character matrices.

Á À Â Ã Ä Ç È É Ê Ë Ì Í Î Ï Ñ Ó Ô Õ Ö Ù Ú Û Ü
á à â ã ä å ç è é ê ë ì í î ï ï ï
á à á ä å ã ç è é ê ë ì í î ï ï ï
ñ ó ò ô õ ö ö ú ù û ü ü ý ÿ
ñ ó ò ó ö ö ö ú ù ú ü ü ü ý ÿ
Æ æ Œ œ --- ¥ £ “ ” ¡ ¢
Æ æ Œ œ L --- L L ¥ £ “ ” ¡ ¢

Duplicate Character Matrices.

Æ Œ œ œ

One-Letter Matrices to be used for two-letter work.

§ ¶ || † ‡ - ¢ / + + - × × ÷ =
1/3 2/3 1/5 2/5 3/5 4/5 1/6 5/6 1/8 1/8 1/8 1/8 1/8 1/8 1/8 1/8 1/8 1/8

Superior: abcdefghijklmnopqrstuvwxyz abcdefghijklmnopqrstuvwxyz

Superior: 1 2 3 4 5 6 7 8 9 0

☺ ☹ ☺ ☹ ● ○ ⊕ ⊗ △ * ♀ ♀ ♂ ♂
⊗ ⊗ Ω ℥ † ≡ ∞ ♂ ♂ ♂ ♀ Π Ψ ℋ ℥ ✕
≡ ℥ ℥ Δ □ ∠ ≡ ≡ √ < > ± ± ∴ ∴ ∴
☛ # ' ° ° " " ☛ * ☛ m/n % % % % ☛
☛ 111111 ☛

MERGENTHALER LINOTYPE CO.

7- POINT CASLON WITH ITALIC AND SMALL CAPS [TWO-LETTER]

Lower case alphabet 13.28 ems

THE MOST ancient materials employed for recording events were bricks, tiles, shells, and tables of stone. The modes of writing on these different substances were various. The tiles and brick were impressed with a stamp when in a soft state; the shells and tablets of stone were etched or graven, the figures or characters being cut in their surface, and in some cases also stained with various colors. It was by the ancient art of stamping that the walls, palaces, and towers of Babylon were covered with hieroglyphics, which have but recently been brought to light from under the immense mounds of Mesopotamia by Layard and other explorers. The patriarch Job, who is supposed to have lived about 2,300 years after the creation exclaimed, "*O that my words were now written! O that they were printed in a book! that they were graven with an iron pen, and hid in the rock for-*

THE MOST ancient materials used for recording events were bricks, tiles, shells, and tables of stone. The modes of writing on these different substances were various. The tiles and brick were impressed with a stamp when in a soft state; the shells and tablets of stone were etched or graven, the figures or characters being cut in their surface, and in some cases also stained with various colors. It was by the ancient art of stamping that the walls, palaces, and towers of Babylon were covered with hieroglyphics, which have but recently been brought to light from under the immense mounds of Mesopotamia by Layard and other explorers.

ABCDEFGHIJKLMNOPQRSTUVWXYZ&
ABCDEFGHIJKLMNOPQRSTUVWXYZUN

abcdefghijklmnopqrstuvwxyz

abcdefghijklmnopqrstuvwxyz

1 2 3 4 5 6 7 8 9 0

V B C D E F G R T J

. . . : ! ? (|) * ' ' - . . . fi ff fh fl x α lb £ \$

. . s ; ! ? A I Q O ' ' - L . . . fi y ff w m k h lb £ P

Duplicate Character Matrices

1 2 3 4 5 6 7 8 9 0 fi ff \$ Z & : () x z &

One-Letter Matrices

@ [] 1/8 1/4 3/8 1/2 5/8 3/4 7/8

Special set table characters. Figures and figure space .056; double figure space .112; comma, period, and quotations .028. These sizes will be sent unless otherwise ordered.

Substitute table characters for use with this face can be had as follows: 7-point Caslon two-letter Modernized figures.—Figures and figure space .056; double figure space .112.

Alignment. This face aligns with all 7-point one- and two-letter faces except German.

Will run in all machines.

To avoid errors read notice on page six

MERGENTHALER LINOTYPE CO.

8-POINT CASLON WITH ITALIC AND SMALL CAPS [TWO-LETTER]

Lower case alphabet 13.23 ems

THE MOST ancient materials employed for recording events were bricks, tiles, shells, and tables of stone. *The modes of writing on these different substances were various.* The tiles and brick were impressed with a stamp when in a soft state; the shells and tablets of stone were etched or graven, the figures or characters being cut in their surface, and in some cases also stained with various colors. It was by the ancient art of stamping that the walls, palaces, and towers of Babylon were covered with hieroglyphics, which have but recently been brought to light from under the immense mounds of Mesopotamia by Layard and other

THE MOST ancient materials used for recording events were bricks, tiles, shells, and tables of stone. The modes of writing on these different substances were various. The tiles and brick were impressed with a stamp when in a soft state; the shells and tablets of stone were etched or graven, the figures or characters being cut in their surface, and in some cases also stained with various colors. It was by the ancient art of stamping that the walls, palaces, and towers of Babylon were covered with hieroglyphics, which have but recently been

ABCDEFGHIJKLMN OPQRSTUVWXYZ &
ABCDEFGHIJKLMN OPQRSTUVWXYZUN

abcdefghijklmnopqrstuvwxyz

abcdefghijklmnopqrstuvwxyz

I 2 3 4 5 6 7 8 9 0

V B C D E F G R T J

, . s ; ! ? A I Q O ' ' - - L . . . fi Y ff W M K H lb L P
, . . ; ! ? (|) * ' ' - - . . . fi fi fi fi fi x æ lb L \$

Duplicate Character Matrices

I 2 3 4 5 6 7 8 9 0 fi fi fi \$ Z & : () X z &

One-Letter Matrices

[] @ 1/8 1/4 3/8 1/2 5/8 3/4 7/8

True set table characters. Figures and en quad .056; em quad .112; comma, period, and quotations .028. These sizes will be sent unless otherwise ordered.

Substitute table characters for use with this face can be had as follows: 8-point Caslon Modernized figures.—Figures and en quad .056; em quad .112.

Alignment. This face aligns with all 8-point one- and two-letter faces having low alignment except German.

Will run in all machines.

To avoid errors read notice on page six

MERGENTHALER LINOTYPE CO.

10-POINT CASLON WITH ITALIC AND SMALL CAPS [TWO-LETTER]

Lower case alphabet 11.95 ems

THE MOST ancient materials used for recording events were bricks, tiles, shells, and tables of stone. *The modes of writing on these different substances were various.* The tiles and brick were impressed with a stamp when in a soft state; the shells and tablets of stone were etched or graven, the figures or characters being cut in their surface, and in some cases also stained with various colors. It was by the ancient art of stamping that the walls, palaces, and towers

THE MOST ancient materials used for recording events were bricks, tiles, shells, and tables of stone. The modes of writing on these different substances were various. The tiles and brick were impressed with a stamp when in a soft state; the shells and tables of stone were etched or graven, the figures or characters being cut in their surface, and in some cases also stained

ABCDEFGHIJKLMNOPQRSTUVWXYZ&
ABCDEFGHIJKLMNOPQRSTUVWXYZUN

abcdefghijklmnopqrstuvwxy z

abcdefghijklmnopqrstuvwxy z

I 2 3 4 5 6 7 8 9 0

V B C D E F G R T J

, . : ; ! ? (') * ' ' - - . . . fi ff ffi ffl æ œ ð £ \$

, . S ; ! ? A I Q O ' ' - - L . . . fi y ff W M K H ð £ P

Duplicate Character Matrices

I 2 3 4 5 6 7 8 9 0 fi ffi ffl \$ Z € : () x z &

One-Letter Matrices

@ [] 1/8 1/4 3/8 1/2 5/8 3/4 7/8

True set table characters. Figures and en quad .070; em quad .140; comma, period, and quotations .035. These sizes will be sent unless otherwise ordered.

Substitute table characters for use with this face can be had as follows: 10-point Caslon Modernized figures.—Figures and en quad .070; em quad .140.

Alignment. This face aligns with all 10-point one- and two-letter faces except German.

Will run in all machines.

To avoid errors read notice on page six

MERGENTHALER LINOTYPE CO.

11-POINT CASLON WITH ITALIC AND SMALL CAPS
[TWO-LETTER]

Lower case alphabet 12.56 ems

THE MOST ancient materials employed for recording events were bricks, tiles, shells, and tables of stone. *The modes of writing on these different substances were various.* The tiles and brick were impressed with a stamp when in a soft state; the shells and tablets of stone were etched or graven, the figures or characters being cut in their surface,

THE MOST ancient materials used for recording events were bricks, tiles, shells, and tables of stone. The modes of writing on these different materials were various. The tiles and brick were impressed with a stamp when in a soft state; the shells and tablets of stone were etched or graven,

ABCDEFGHIJKLMN OPQRSTUVWXYZ &
ABCDEFGHIJKLMN OPQRSTUVWXYZ UN

abcdefghijklmnopqrstuvwxy z
abcdefghijklmnopqrstuvwxy z

I 2 3 4 5 6 7 8 9 0

V B C D E F G R T J

, . : ; ! ? (|) * ' - — . . . fi ff ffi ffl æ œ lb £ \$
, . S ; ! ? A I Q O ' ' - — L . . . fi Y ff W M K H lb £ P

Duplicate Character Matrices.

I 2 3 4 5 6 7 8 9 0 fi ffi ffl \$ Z & : () X Z &

One-Letter Matrices

@ [] 1/8 1/4 3/8 1/2 5/8 3/4 7/8

Special set table characters. Figures and figure space .084; double figure space .168; comma, period, and quotations .042. These sizes will be sent unless otherwise ordered.

Substitute table characters for use with this face can be had as follows: 11-point Caslon Modernized figures.—Figures and figure space .084; double figure space .168.

Alignment. This face aligns with all 11-point one and two-letter faces except German.

Will run in all machines.

To avoid errors read notice on page six

MERGENTHALER LINOTYPE CO.

12-POINT CASLON WITH ITALIC AND SMALL CAPS
[TWO-LETTER]

Lower case alphabet 12.91 ems

THE MOST ancient materials employed for recording events were bricks, tiles, shells, and tables of stone. *The modes of writing on these different substances were various.* The tiles and brick were impressed with a stamp when in a soft state; the shells and tablets of stone

THE MOST ancient materials employed for recording events were bricks, tiles, shells, and tables of stone. The modes of writing on these different substances varied. The tiles and brick were *impressed* with a stamp when in a soft state; the shells and tablets of stone were

ABCDEFGHIJKLMN OPQRSTUVWXYZ &
ABCDEFGHIJKLMN OPQRSTUVWXYZ UN

abcdefghijklmnopqrstuvwxy z
abcdefghijklmnopqrstuvwxy z

I 2 3 4 5 6 7 8 9 0
V B C D E F G R T J

, . : ; ! ? (|) * ' ' — . . . fi fl ff ffi ffl æ œ ð £ \$
, . S ; ! ? A I Q O ' ' — L . . . fi Y ff W M K H ð £ P

Duplicate Character Matrices.

I 2 3 4 5 6 7 8 9 0 fl ffi ffl \$ Z & : () X Z &

One-Letter Matrices

@ [] 1/8 1/4 3/8 1/2 5/8 3/4 7/8

True set table characters. Figures and en quad .084; em quad .168; comma, period, and quotations .042. These sizes will be sent unless otherwise ordered.

Substitute table characters for use with this face can be had as follows: 12-point Caslon Modernized figures.—Figures and en quad .084; em quad .168.

Alignment. This face aligns with all 12-point one- and two-letter faces except German.

Will run in machines Nos. 2, 3, 4 and 5.

To avoid errors read notice on page six

MERGENTHALER LINOTYPE CO.

6-POINT DE VINNE SERIES WITH ITALIC AND SMALL CAPS [ONE-LETTER]

Lower case alphabet 15.35 ems

THE MOST ancient materials employed for recording events were bricks, tiles, shells, and tables of stone. The modes of writing on these different substances were various. The tiles and brick were impressed with a stamp when in a soft state; the shells and tablets of stone were etched or graven, the figures or characters being cut in their surface, and in some cases also stained with various colors. It was by the ancient art of stamping that the walls, palaces, and towers of Babylon were covered with hieroglyphics, which have but recently been brought to light from under the immense mounds of Mesopotamia by Layard and other explorers. The patriarch Job, who is supposed to have lived about 2,300 years after the creation, exclaimed, "*O that my words were now written! O that they were printed in a book! that they were graven with an iron pen, and hid in the rock forever!*" Stung with the unjust accusation of his friends, he desires to record his words that the generations following

THE MOST ancient materials employed for recording events were bricks, tiles, shells, and tables of stone. The modes of writing on these different substances were various. The tiles and brick were impressed with a stamp when in a soft state; the shells and tablets of stone were etched or graven, the figures or characters being cut in their surface, and in some cases also stained with various colors. It was by the ancient art of stamping that the walls, palaces, and towers of Babylon were covered with hieroglyphics, which have but recently been brought to light from under the immense mounds of Mesopotamia by Layard and other explorers. The patriarch Job, who is supposed to have lived about 2,300 years after the creation, exclaimed, "*O that my words were now written! O that they were printed in a book! that they were graven with an iron pen, and*

ABCDEFGHIJKLMN OPQRSTUVWXYZ&
ABCDEFGHIJKLMN OPQRSTUVWXYZ

abcdefghijklmnopqrstuvwxy
abcdefghijklmnopqrstvwxyz

1 2 3 4 5 6 7 8 9 0
V B C D E F G R T J

, . : ; ! () * ' ' - . . . ß ſ ſ ſ ſ ſ œ ð £ \$
, . s ; ! ? A I Q O ' ' - L . . . ß Y ſ W M K H D £ P

In Auxillary Position. One-Letter Matrices.
1 2 3 4 5 6 7 8 9 0 ß ſ ſ ſ : () Z & x z & @ [] ¼ ½ ¾ ⅓ ⅔ ⅕ ⅖ ⅗ ⅘

Special set table characters. Figures and figure space .0553; double figure space .1107; comma, period, and quotations .0277. Unit system, ¼-point basis. These sizes will be sent unless otherwise ordered.

Alignment. This face aligns with all 6-point one- and two-letter faces except German.

Will run in all machines.

To avoid errors read notice on page six

MERGENTHALER LINOTYPE CO.

8-POINT DE VINNE SERIES WITH ITALIC AND SMALL CAPS [TWO-LETTER]

Lower case alphabet 13.49 ems

THE MOST ancient materials employed for recording events were bricks, tiles, shells, and tables of stone. *The modes of writing on these different substances were various.* The tiles and brick were impressed with a stamp when in a soft state; the shells and tablets of stone were etched or graven, the figures or characters being cut in their surface, and in some cases also stained with various colors. It was by the ancient art of stamping that the walls, palaces, and towers of Babylon were covered with hieroglyphics, which have but recently been brought to light from under the immense mounds of Mesopotamia by Layard and other

THE MOST ancient materials employed for recording events were bricks, tiles, shells, and tables of stone. The modes of writing on these different substances were various. The tiles and brick were impressed with a stamp when in a soft state; the shells and tablets of stone were etched or graven, the figures or characters being cut in their surface, and in some cases also stained with various colors. It was by the ancient art of stamping that the walls, palaces, and towers of Babylon were covered with

ABCDEFGHIJKLMN O P Q R S T U V W X Y Z &
ABCDEFGHIJKLMN O P Q R S T U V W X Y U N

abcdefghijklmnopqrstuvwxyz

abcdefghijklmnopqrstuvwxyz

1 2 3 4 5 6 7 8 9 0

V B C D E F G R T J

, . : ; ! ? (|) * ' ' - . . . fi ff ffi fl æ œ ð £ \$

, . S ; ! ? A I Q O ' ' - - L . . . ß Y ff W M K H ð £ P

Duplicate Character Matrices

1 2 3 4 5 6 7 8 9 0 ß fi ffi \$ Z & : () x z &

One-Letter Matrices

@ [] 1/8 1/4 3/8 1/2 5/8 3/4 7/8

Special set table characters. Figures and figure space .059; double figure space .118; comma and period .0295; quotations .050. These sizes will be sent unless otherwise ordered.

Substitute table characters for use with this face can be had as follows: 8-point No. 4 figures with 8-point Clarendon No. 1 figures.—Figures and figure space .059; double figure space .118.

Alignment. This face aligns with all 8-point one- and two-letter faces having high alignment except German. Will run in all machines.

To avoid errors read notice on page six

MERGENTHALER LINOTYPE CO.

9-POINT DE VINNE SERIES WITH ITALIC AND SMALL CAPS [TWO-LETTER]

Lower case alphabet 12.92 ems

THE MOST ancient materials employed for recording events were bricks, tiles, shells, and tables of stone. The modes of writing on these *different substances were various*. The tiles and brick were impressed with a stamp when in a soft state; the shells and tablets of stone were etched or graven, the figures or characters being cut in their surface, and in some cases also stained with various colors. It was by the ancient art of stamping that the walls, palaces, and towers of Babylon were covered with hieroglyphics, which have but recent-

THE MOST ancient materials used for recording events were bricks, tiles, shells, and tables of stone. The modes of writing on these different substances were various. The tiles and brick were impressed with a stamp when in a soft state; the shells and tablets of stone were etched or graven, the figures or characters being cut in their surface, and in some cases also stained with various colors. It was by the ancient art of stamping that the walls,

ABCDEFGHIJKLMN OPQRSTUVWXYZ &
ABCDEFGHIJKLMN OPQRSTUVWXYZ UN

abcdefghijklmnopqrstuvwxyz

abcdefghijklmnopqrstuvwxyz

1 2 3 4 5 6 7 8 9 0

V B C D E F G R T J

, . : ; ! ? (|) * ' ' - fi fi ff ffi ffi æ œ lb £ \$
, . 8 ; ! ? A I Q O ' ' - - L fi Y ff W M K H D £ P

Duplicate Character Matrices

1 2 3 4 5 6 7 8 9 0 fi ffi ffi \$ Z & : () x z &

One-Letter Matrices

@ [] 1/8 1/4 3/8 1/2 5/8 3/4 7/8

True set table characters. Figures and en quad .063; em quad .126; comma, period, and quotations .0315. These sizes will be sent unless otherwise ordered.

Alignment. This face aligns with all 9-point one- and two-letter faces except German.

Will run in all machines.

To avoid errors read notice on page six

MERGENTHALER LINOTYPE CO.

10-POINT DE VINNE SERIES WITH ITALIC AND SMALL CAPS
[TWO-LETTER]

Lower case alphabet 12.96 ems

THE MOST ancient materials employed for recording events were bricks, tiles, shells, and tables of stone. *The modes of writing on these different substances were various.* The tiles and brick were impressed with a stamp when in a soft state; the shells and tablets of stone were etched or graven, the figures or characters being cut in their surface, and in some cases also stained with various colors. It was by the ancient art of stamping that the walls, palaces, and towers of

THE MOST ancient materials used for recording events were bricks, tiles, shells, and tables of stone. The modes of writing on these different substances were various. The tiles and brick were impressed with a stamp when in a soft state; the shells and tablets were etched or graven, the figures or characters being cut in their surface, and in some cases also stained with various

ABCDEFGHIJKLMN OPQRSTUVWXYZ &
ABCDEFGHIJKLMN OPQRSTUVWXYZ UN

abcdefghijklmnopqrstuvwxyz
abcdefghijklmnopqrstuvwxyz

1 2 3 4 5 6 7 8 9 0

V B C D E F G R T J

, . : ; ! ? (|) * ' ' - - . . . fi fl ff ffi ffl æ œ ð £ \$

, . S ; ! ? A I Q O ' ' - - L . . . fi Y ff W M K H ð £ P

Duplicate Character Matrices

1 2 3 4 5 6 7 8 9 0 fl ffi ffl \$ Z & : () x z &

One-Letter Matrices

@ [] 1/8 1/4 3/8 1/2 5/8 3/4 7/8

True set table characters. Figures and en quad .070; em quad .140; comma and period .035. These sizes will be sent unless otherwise ordered.

Alignment. This face aligns with all 10-point one- and two-letter faces except German.

Will run in all machines.

To avoid errors read notice on page six

MERGENTHALER LINOTYPE CO.

11-POINT DE VINNE SERIES WITH ITALIC AND SMALL CAPS
[TWO-LETTER]

Lower case alphabet 13.34 ems

THE MOST ancient materials used for recording events were bricks, tiles, shells, and tables of stone. *The modes of writing on these different substances were various.* The tiles and brick were impressed with a stamp when in a soft state; the shells and tablets of stone were etched or graven, the figures or characters being cut in their surface, and in some cases also stained with

THE MOST ancient materials used for recording events were bricks, tiles, shells, and tables of stone. The modes of writing on these different substances were various. The tiles and brick were impressed with a stamp when in a soft state; the shells and tablets of stone were

ABCDEFGHIJKLMN OPQRSTUVWXYZ &
ABCDEFGHIJKLMN OPQRSTUVWXYZ UN

abcdefghijklmnopqrstuvwxyz
abcdefghijklmnopqrstuvwxyz

1 2 3 4 5 6 7 8 9 0

V B C D E F G R T J

, . : ; ! ? (|) * ' ' ' - . . . fi fl ff ffi ffl æ œ £ lb \$
, . S ; ! ? A I Q O ' ' - - L . . . fi Y ff W M K H £ ll P

Duplicate Character Matrices.

1 2 3 4 5 6 7 8 9 0 fl ffi ffl \$ Z & : () X Z &

One-Letter Matrices

@ [] 1/8 1/4 3/8 1/2 5/8 3/4 7/8

True set table characters. Figures and en quad .077; em quad .154; comma and period .0385. These sizes will be sent unless otherwise ordered.

Alignment. This face aligns with all 11-point one and two-letter faces except German.

Will run in all machines.

To avoid errors read notice on page six

MERGENTHALER LINOTYPE CO.

12-POINT DE VINNE SERIES WITH ITALIC AND SMALL CAPS
[TWO-LETTER]

Lower case alphabet 13.40 ems

THE MOST ancient materials employed for recording events were bricks, tiles, shells, and tables of stone. *The modes of writing on these different substances were various* The tiles and brick were impressed with a stamp when in a soft state; the shells and tablets of stone were etched or graven, the

THE MOST ancient materials used for recording events were bricks, tiles, shells, and tables of stone. The modes of writing on these different substances varied. The tiles and brick were impressed with *a stamp* when in a soft state; the shells and tablets

ABCDEFGHIJKLMN OPQRSTUVWXYZ &
ABCDEFGHIJKLMN OPQRSTUVWXYZ UN

abcdefghijklmnopqrstuvwxy
abcdefghijklmnopqrstuvwxyz

1 2 3 4 5 6 7 8 9 0

V B C D E F G R T J

, . : ; ! ? (|) * ' - — . . . fi ff ffi ffl æ œ ð £ \$
, . S ; ! ? AI Q O ' ' - — L . . . fl Y ff W M K H ð £ P

Duplicate Character Matrices.

1 2 3 4 5 6 7 8 9 0 fl ffi ffl \$ Z & : () x z &

One-Letter Matrices

@ [] 1/8 1/4 3/8 1/2 5/8 3/4 7/8

True set table characters. Figures and en quad .084; em quad .168; comma and period .042. These sizes will be sent unless otherwise ordered.

Alignment. This face aligns with all 12-point one- and two-letter faces except German.

Will run in machines Nos. 2, 3, 4 and 5.

To avoid errors read notice on page six

SPECIMENS OF LINOTYPE FACES

12-POINT
DE VINNE
SERIES
WITH
ITALIC AND
SMALL CAPS
Two-Letter

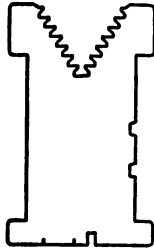

SPECIAL
CHARACTERS

Low Cap Accents—Regular mold may be used.

Á À Â Ã Ä Ç È É Ê Ë Ì Í Î Ñ Ò Ó Ô Õ Ö Ù Ú Û Ü Û
 Á À Â Ã Ä Ç È É Ê Ë Ì Í Î Ñ Ò Ó Ô Õ Ö Ù Ú Û Ü Û
 á à â ã ä å ç è é ê ë ì í î ñ ò ó ô õ ö ù ú û ü ù
 á à â ã ä å ç è é ê ë ì í î ñ ò ó ô õ ö ù ú û ü ù
 Æ œ Œ œ £ ¥ “ ” ¡ ¢ §
 Æ œ Œ œ £ ¥ “ ” ¡ ¢ §

L - - - L L
 1 2 3 4 5 6 7 8 9 0 \$ Z & : () fl ffi ffl
 1 2 3 4 5 6 7 8 9 0 \$ Z & : () fl ffi ffl

Duplicate Character Matrices.
Small Cap Accents.

Á À Â Ã Ä Ç È É Ê Ë Ì Í Î Ñ Ò Ó Ô Õ Ö Ù Ú Û Ü Û
 Æ Œ œ œ ... | *

One-Letter Matrices to be used for two-letter work.

One-Letter Accents—Low Caps.

Ā Ă Ä Å Æ Ē Ē Ē Ē Ē Ē Ē Ē Ē Ē Ē Ē Ē Ē Ē Ē Ē
 ā ă ą ą ą ę ę ę ę ę ę ę ę ę ę ę ę ę ę ę ę ę
 § ¶ || † ‡ - ¢ / + + - × × ÷ =
 1/3 2/3 1/5 2/5 3/5 4/5 1/6 5/6 1/8 3/8 5/8 7/8
 1/8 1/4 3/8 1/2 5/8 3/4 7/8 1/3 2/3 1/5 2/5 3/5 1/6

Superior: abcdefghijklmnopqrstuvwxyz abcdefghijklmnopqrstuvwxyz
Superior: 1 2 3 4 5 6 7 8 9 0

☉ ☺ ☻ ☼ ☽ ☾ ☿ ♀ ♁ ♂
 ☽ ☿ ♀ ♁ ♂ ☽ ☿ ♀ ♁ ♂ ☽ ☿ ♀ ♁ ♂
 ☽ ☿ ♀ ♁ ♂ ☽ ☿ ♀ ♁ ♂ ☽ ☿ ♀ ♁ ♂
 ☽ ☿ ♀ ♁ ♂ ☽ ☿ ♀ ♁ ♂ ☽ ☿ ♀ ♁ ♂

MERGENTHALER LINOTYPE CO.

6-POINT DE VINNE SERIES WITH ANTIQUE NO. 3

[TWO-LETTER]

Lower case alphabet 16.06 ems

The most ancient materials used for recording events were bricks, tiles, shells and tables of stone. The modes of writing on these different substances were various. The tiles and brick were impressed with a stamp when in a soft state; the shells and tablets of stone were etched or graven, the figures or characters being cut in their surface, and in some cases also stained with various colors. It was by the ancient art of stamping that the walls, palaces, and towers of Babylon were covered with hieroglyphics, which have but recently been brought to light from under the immense mounds of Mesopotamia by Layard and other explorers. The patriarch Job, who is supposed to have lived about 2,300 years after the creation, exclaimed, "O that my words were now written! O that they were printed in a book! that they were graven with an iron pen and hid in the rock forever!" Stung with the unjust accusation of his friends, he desires to record his words that the

The most ancient materials used for recording events were bricks, tiles, shells, and tables of stone. The modes of writing on these different substances were various. The tiles and brick were impressed with a stamp when in a soft state; the shells and tablets of stone were etched or graven, the figures or characters being cut in their surface, and in some cases also stained with various colors. It was by the ancient art of stamping that the walls, palaces, and towers of Babylon were covered with hieroglyphics, which have but recently been brought to light from under the immense mounds of Mesopotamia by Layard and other explorers. The patriarch Job, who is supposed to have lived about 2,300 years after the creation, exclaimed, "O that my words were now written! O that they were printed in a book!

ABCDEFGHIJKLMNOPQRSTUVWXYZ&

ABCDEFGHIJKLMNOPQRSTUVWXYZ&

abcdefghijklmnopqrstuvwxyz

abcdefghijklmnopqrstuvwxyz

1 2 3 4 5 6 7 8 9 0

1 2 3 4 5 6 7 8 9 0

.,:;! ? (|) * ' ' - ñ ñ ñ ñ ñ ñ ñ @ £ \$ []
 .,:;! ? (|) * ' ' - ñ ñ ñ ñ ñ ñ ñ @ £ \$ []

¼ ½ ¾ ¼ ½ ¾ ¼ ½

¼ ½ ¾ ¼ ½ ¾ ¼ ½

Special set table characters. Figures and figure space .056; double figure space .112; comma, period, and quotations .028. These sizes will be sent unless otherwise ordered.

Substitute table characters for use with this face can be had as follows: 6-point De Vinne with Gothic No. 7 two-letter.—Figures and figure space .056; double figure space .112.

Alignment. This face aligns with all 6-point one- and two-letter faces except German.

Will run in all machines.

To avoid errors read notice on page six

MERGENTHALER LINOTYPE CO.

8-POINT DE VINNE SERIES WITH ANTIQUE NO. 3

[TWO-LETTER]

Lower case alphabet 14.19 ems

The most ancient materials employed for recording events were bricks, tiles, shells, and tables of stone. The modes of writing on these different substances were various. The tiles and brick were impressed with a stamp when in a soft state; the shells and tablets of stone were etched or graven, the figures or characters being cut in their surface, and in some cases also stained with various colors. It was by the ancient art of stamping that the walls, palaces, and towers of Babylon were covered with hieroglyphics, which have but recently been brought to light from under the immense mounds of Mesopotamia by Layard and other explorers. The patriarch

The most ancient materials employed for recording events were bricks, tiles, shells, and tables of stone. The modes of writing on these different substances were various. The tiles and brick were impressed with a stamp when in a soft state; the shells and tablets of stone were etched or graven, the figures or characters being cut in their surface, and in some cases also stained with various colors. It was by the ancient art of stamping that the walls, palaces, and towers of Babylon were covered

ABCDEFGHIJKLMN OPQRSTUVWXYZ&

ABCDEFGHIJKLMN OPQRSTUVWXYZ&

abcdefghijklmnopqrstuvwxyz

abcdefghijklmnopqrstuvwxyz

1 2 3 4 5 6 7 8 9 0

1 2 3 4 5 6 7 8 9 0

, . : ; ! ? (|) * ' ' - - fi ff ff ff lb @ £ \$ []

, . : ; ! ? (|) * ' ' - - fi ff ff ff lb @ £ \$ []

1/8 1/4 3/8 1/2 5/8 3/4 7/8

1/8 1/4 3/8 1/2 5/8 3/4 7/8

Special set table characters. Figures and figure space .059; double figure space .118; comma and period .0295; quotations .050. These sizes will be sent unless otherwise ordered.

Substitute table characters for use with this face can be had as follows: 8-point No. 4 figures with 8-point Clarendon No. 1 figures.—Figures and figure space .059; double figure space .118.

Alignment. This face aligns with all 8-point one- and two-letter faces having high alignment except German.

Will run in all machines.

To avoid errors read notice on page six

MERGENTHALER LINOTYPE CO.

9-POINT DE VINNE SERIES WITH ANTIQUE NO. 3

[TWO-LETTER]

Lower case alphabet 13.18 ems

The most ancient materials employed for recording events were bricks, tiles, shells, and tables of stone. The modes of writing on these different substances were various. The tiles and brick were impressed with a stamp when in a soft state; the shells and tablets of stone were etched or graven, the figures or characters being cut in their surface, and in some cases also stained with various colors. It was by the ancient art of stamping that the walls, palaces, and towers of Babylon were covered with hieroglyphics, which

The most ancient materials used for recording events were bricks, tiles, shells, and tables of stone. The modes of writing on these different substances were various. The tiles and brick were impressed with a stamp when in a soft state; the shells and tablets of stone were etched or graven, the figures or characters being cut in their surface, and in some cases also stained with various colors. It was by the ancient art of stamping

ABCDEFGHIJKLMNOPQRSTUVWXYZ&
ABCDEFGHIJKLMNOPQRSTUVWXYZ&

abcdefghijklmnopqrstuvwxy

abcdefghijklmnopqrstuvwxy

1 2 3 4 5 6 7 8 9 0

1 2 3 4 5 6 7 8 9 0

, . : ; ! ? (|) * ' ' - — fi ff fl fl ll lb @ £ \$ []

, . : ; ! ? (|) * ' ' - — fi ff fl fl ll lb @ £ \$ []

1/8 1/4 3/8 1/2 5/8 3/4 7/8

1/8 1/4 3/8 1/2 5/8 3/4 7/8

True set table characters. Figures and en quad .063; em-quad .126; comma, period, and quotations .0315. These sizes will be sent unless otherwise ordered.

Alignment. This face aligns with all 9-point one- and two-letter faces except German.

Will run in all machines.

To avoid errors read notice on page six

MERGENTHALER LINOTYPE CO.

10-POINT DE VINNE SERIES WITH ANTIQUE NO. 3
[TWO-LETTER]

Lower case alphabet 13.44 ems

The most ancient materials employed for recording events were bricks, tiles, shells, and tables of stone. The modes of writing on these different substances were various. The tiles and brick were impressed with a stamp when in a soft state; the shells and tablets of stone were etched or graven, the figures or characters being cut in their surface, and in some cases also stained with various colors. It was by the ancient art of stamping that the walls, palaces, and towers of Babylon were covered with hieroglyphics,

The most ancient materials used for recording events were bricks, tiles, shells, and tables of stone. The modes of writing on these different substances were various. The tiles and brick were impressed with a stamp when in a soft state; the shells and tablets of stone were etched or graven, the figures or characters being cut in their sur-

ABCDEFGHIJKLMN OPQRSTUVWXYZ&
ABCDEFGHIJKLMN OPQRSTUVWXYZ&

abcdefghijklmnopqrstuvwxy
abcdefghijklmnopqrstuvwxy

1 2 3 4 5 6 7 8 9 0
1 2 3 4 5 6 7 8 9 0

, . : ; ! ? (|) * ' ' - — fi ff ffi ffl lb @ £ \$ []
, . : ; ! ? (|) * ' ' - — fi ff ffi ffl lb @ £ \$ []

1/8 1/4 3/8 1/2 5/8 3/4 7/8
1/8 1/4 3/8 1/2 5/8 3/4 7/8

True set table characters. Figures and en quad .070; em quad .140; comma and period .035. These sizes will be sent unless otherwise ordered.

Alignment. This face aligns with all 10-point one- and two-letter faces except German.

Will run in all machines.

To avoid errors read notice on page six

MERGENTHALER LINOTYPE CO.

11-POINT DE VINNE SERIES WITH ANTIQUE NO. 3
[TWO-LETTER]

Lower case alphabet 13.43 ems

The most ancient materials used for recording events were bricks, tiles, shells, and tables of stone. The modes of writing on these different substances were various. The tiles and brick were impressed with a stamp when in a soft state; the shells and tablets of stone were etched or graven, the figures or characters being cut in

The most ancient materials used for recording events were bricks, tiles, shells, and tables of stone. The modes of writing on these different substances were various. The tiles and brick were impressed with a stamp when in a soft state; the shells and tablets of stone were etched or graven, the figures or characters being cut in

ABCDEFGHIJKLMN OPQRSTUVWXYZ&
ABCDEFGHIJKLMN OPQRSTUVWXYZ&
abcdefghijklmnopqrstuvwxy
abcdefghijklmnopqrstuvwxy

1 2 3 4 5 6 7 8 9 0
1 2 3 4 5 6 7 8 9 0

, . : ; ! ? (|) * ' ' - - fi ff ffi ffl lb £ \$
, . : ; ! ? (|) * ' ' - - fi ff ffi ffl lb £ \$

@ [] 1/8 1/4 3/8 1/2 5/8 3/4 7/8
@ [] 1/8 1/4 3/8 1/2 5/8 3/4 7/8

True set table characters. Figures and en quad .077; em quad .154; comma, period, and quotations .0385. These sizes will be sent unless otherwise ordered.

Substitute table characters for use with this face can be had as follows: 11-point No. 9 figures with Clarendon No. 1 figures.—Figures and en quad .077; em quad .154.

Alignment. This face aligns with all 11-point one and two-letter faces except German.

Will run in all machines.

To avoid errors read notice on page six

MERGENTHALER LINOTYPE CO.

12-POINT DE VINNE SERIES WITH ANTIQUE NO. 3
[TWO-LETTER]

Lower case alphabet 13.55 ems

The most ancient materials employed for recording events were bricks, tiles, shells, and tables of stone. The modes of writing on these different substances were various. The tiles and brick were impressed with a stamp when in a soft state; the shells and tablets of stone were etched or graven, the figures or characters being cut in their sur-

The most ancient materials used for recording events were bricks, tiles, shells, and tables of stone. The modes of writing on these different substances varied. The tiles and brick were impressed with a stamp when in a soft

ABCDEFGHIJKLMN OPQRSTUVWXYZ &
ABCDEFGHIJKLMN OPQRSTUVWXYZ &

abcdefghijklmnopqrstuvwxy
abcdefghijklmnopqrstuvwxy

1 2 3 4 5 6 7 8 9 0

1 2 3 4 5 6 7 8 9 0

, . : ; ! ? (|) * ' ' - _ fi fl ff ffi ffl lb £ \$
, . : ; ! ? (|) * ' ' - _ fi fl ff ffi ffl lb £ \$

@ [] 1/8 1/4 3/8 1/2 5/8 3/4 7/8
@ [] 1/8 1/4 3/8 1/2 5/8 3/4 7/8

True set table characters. Figures and en quad .084; em quad .168; comma and period .042. These sizes will be sent unless otherwise ordered.

Alignment. This face aligns with all 12-point one- and two-letter faces except German.

Will run in machines Nos. 2, 3, 4 and 5.

To avoid errors read notice on page six

MERGENTHALER LINOTYPE CO.

8-POINT CHELTENHAM WITH ITALIC AND SMALL CAPS [TWO-LETTER]

Lower case alphabet 11.91 ems

The most ancient materials employed for recording events were bricks, tiles, shells, and tables of stone. *The modes of writing on these different substances were various.* The tiles and brick were impressed with a stamp when in a soft state; the shells and tablets of stone were etched or graven, the figures or characters being cut in their surface, and in some cases also stained with various colors. It was by the ancient art of stamping that the walls, palaces, and towers of Babylon were covered with hieroglyphics, which have but recently been brought to light from under the immense mounds of Mesopotamia by Layard and other ex-

The most ancient materials employed for recording events were bricks, tiles, shells, and tables of stone. The modes of writing on these different substances were various. The tiles and brick were impressed with a stamp when in a soft state; the shells and tablets of stone were etched or graven the figures or characters being cut in their surface, and in some cases also stained with various colors. It was by the ancient art of stamping that the walls, palaces, and towers of Babylon were covered with hieroglyphics, which have but recently been

ABCDEFGHIJKLMN OPQRSTUVWXYZ &
ABCDEFGHIJKLMN OPQRSTUVWXYZ UN

abcdefghijklmnopqrstuvwxyz

abcdefghijklmnopqrstuvwxyz

1 2 3 4 5 6 7 8 9 0

V B C D E F G R T J

. . . ; ! ? (|) * ' ' - — . . . ð ñ ò ó ô õ ö ø ù º » £ \$

. . s ; ! ? A I Q O ' ' - — L . . . ð Y ff w M K H ð £ P

Duplicate Character Matrices

1 2 3 4 5 6 7 8 9 0 \$ Z & : () fl ff ffi x z &

One-Letter Matrices

@ [] 1/8 1/4 3/8 1/2 5/8 3/4 7/8

True set table characters. Figures and en quad .056; em quad .112; comma, period, and quotations .028. These sizes will be sent unless otherwise ordered.

Substitute table characters for use with this face can be had as follows: 8-point Old Style No. 1 Modernized figures.—Figures and en quad .056; em quad .112.

Alignment. This face aligns with all 8-point one- and two-letter faces having low alignment except German.

Will run in all machines.

To avoid errors read notice on page six

MERGENTHALER LINOTYPE CO.

10-POINT CHELTENHAM WITH ITALIC AND SMALL CAPS
[TWO-LETTER]

Lower case alphabet 11.39 ems

THE MOST ancient materials employed for recording events were bricks, tiles, shells, and tables, of stone. *The modes of writing on these different substances were various.* The tiles and brick were impressed with a stamp when in a soft state; the shells and tablets of stone were etched or graven, the figures or characters being cut in their surface, and in some cases also stained with various colors. It was by the ancient art of stamping that the walls, palaces, and towers of Babylon were

THE MOST ancient materials employed for recording events were bricks, tiles, shells, and tables of stone. The modes of writing on these different substances were various. The tiles and brick were impressed with a stamp when in a soft state; the shells and tablets of stone were etched or graven, the figures or characters being cut in their surface, and in some cases also stained with various colors. It was by the ancient art

ABCDEFGHIJKLMN OPQRSTUVWXYZ &
ABCDEFGHIJKLMN OPQRSTUVWXYZ UN

abcdefghijklmnopqrstuvwxyz
abcdefghijklmnopqrstuvwxyz

1 2 3 4 5 6 7 8 9 0

V B C D E F G R T J

. . . ; ! ? (|) * ' ' - — . . . fi ff ffi ffl æ œ ð £ \$
. . . S ; ! ? A I Q O ' ' - — L . . . fi Y ff W M K H ð £ P

In Auxiliary Position.

1 2 3 4 5 6 7 8 9 0 fl ffi ffl \$ Z & : () x Z &

One-Letter Matrices

@ [] 1/8 1/4 3/8 1/2 5/8 3/4 7/8

Special set table characters. Figures and figure space .077; double figure space .154; comma, period, and quotations .0385. These sizes will be sent unless otherwise ordered.

Alignment. This face aligns with all 10-point one- and two-letter faces except German. Will run in all machines.

To avoid errors read notice on page six

MERGENTHALER LINOTYPE CO.

12-POINT CHELTENHAM WITH ITALIC AND SMALL CAPS
[TWO-LETTER]

Lower case alphabet 11.11 ems

THE MOST ancient materials employed for recording events were bricks, tiles, shells, and tables of stone. *The modes of writing on these different substances were various.* The tiles and brick were impressed with a stamp when in a soft state; the shells and tablets of stone were etched or graven, the figures or characters being cut in their surface, and in some cases also stained with various colors

THE MOST ancient materials used for recording events were bricks, tiles, shells, and tables of stone. The modes of writing on these different substances were various. The tiles and brick were impressed with a stamp when in a soft state;

ABCDEFGHIJKLMN OPQRSTUVWXYZ &
ABCDEFGHIJKLMN OPQRSTUVWXYZ UN

abcdefghijklmnopqrstuvwxyz

abcdefghijklmnopqrstuvwxyz

1 2 3 4 5 6 7 8 9 0

V B C D E F G R T J

., . ; ! ? (|) * ' ' - — . . . fi fl ff ffi ffl æ œ lb £ \$

., . S ; ! ? A I Q O ' ' - — L . . . fi Y ff W M K H lb £ P

In Auxiliary Position.

1 2 3 4 5 6 7 8 9 0 fl ffi ffl Z & \$: () x z &

One-Letter Matrices

@ [] 1/8 1/4 3/8 1/2 5/8 3/4 7/8

True set table characters. Figures and err quad .084; em quad .168; comma, period, and quotations .042. These sizes will be sent unless otherwise ordered.

Alignment. This face aligns with all 12-point one- and two-letter faces except German.

Will run in machines Nos. 2, 3, 4 and 5.

To avoid errors read notice on page six

SPECIMENS OF LINOTYPE FACES

**12-POINT
CHELTENHAM
WITH
ITALIC AND
SMALL CAPS
Two-Letter**

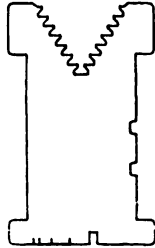

**SPECIAL
CHARACTERS**

Low Cap Accents—Regular mold may be used.

Á É Í Ñ Ó Ú Û
Á É Í Ñ Ó Ú Û

á à â ä ç é è ê ë í î ï ñ ó ò ô ö ú û ü
 á à â ä ç é è ê ë í î ï ñ ó ò ô ö ú û ü

Æ æ Œ œ H i ç
 Æ æ Œ œ K L j ç Æ Œ

One-Letter Matrices to be used for two-letter work.

ct st Qu § ¶ || † ‡ - ç / + + - × × ÷ =

$\frac{1}{3}$ $\frac{2}{3}$ $\frac{1}{5}$ $\frac{2}{5}$ $\frac{3}{5}$ $\frac{4}{5}$ $\frac{1}{6}$ $\frac{5}{6}$

$\frac{1}{8}$ $\frac{1}{4}$ $\frac{3}{8}$ $\frac{1}{2}$ $\frac{5}{8}$ $\frac{3}{4}$ $\frac{7}{8}$ $\frac{1}{3}$ $\frac{2}{3}$ $\frac{1}{5}$ $\frac{2}{5}$ $\frac{3}{5}$ $\frac{4}{5}$ $\frac{1}{6}$ $\frac{5}{6}$

Superior: abcdefghijklmnopqrstuvwxyz abcdefghijklmnopqrstuvwxyz

Superior: 1 2 3 4 5 6 7 8 9 0

☺ ☻ ☽ ☾ ☾ ☹ ● ⊕ ⊗ ⚠ * ✕ ♀ ♂ ♂
 ♂ ♂ ♀ ♀ ♀ ♀ ♂ ♂ ♂ ♂ ♂ ♂ ♂ ♂ ♂ ♂ ♂
 ≡ ℏ ℓ ℓ Δ □ ∠ ≅ ≅ √ < > ± ∓ ∴ ∴ ∴ ∴
 ➔ # ' " ° ° « » ¶ * ¶ ‰ ‰ ‰ ‰ % % % % ➔
 ➔ ⸮ ⸮ ⸮ ⸮ — — — — — — — — — — ➔

MERGENTHALER LINOTYPE CO.

14-POINT CHELTENHAM WITH ITALIC AND SMALL CAPS
[TWO-LETTER]

Lower case alphabet 11.20 ems

THE MOST ancient materials employed for recording events were bricks, tiles, shells, and tables of stone. *The modes of writing on these different substances were various.* The tiles and brick were impressed with a stamp when in a soft state; the shells and tablets

THE MOST ancient materials used in recording events were bricks, tiles, shells, and tables of stone. The modes of writing on these different substances were various. The tiles and brick were stamped

ABCDEFGHIJKLMN OPQRSTUVWXYZ &
ABCDEFGHIJKLMN OPQRSTUVWXYZ UN

abcdefghijklmnopqrstuvwxy
abcdefghijklmnopqrstuvwxy

1 2 3 4 5 6 7 8 9 0

V B C D E F G R T J

, . : ; ! ? (|) * ' " - — . . . fi fl ff ffi ffl æ œ ð £ \$
, . S ; ! ? AIQO ' " - — L . . . fi Y ff WM KH ð £ P

In Auxiliary Position.

1 2 3 4 5 6 7 8 9 0 fl ffi ffl Z & \$: () x z &

One-Letter Matrices

@ [] 1/8 1/4 3/8 1/2 5/8 3/4 7/8

True set table characters. Figures and en quad .0968; em quad .1936; comma, period, and quotations .0484. Unit system, 1/4-point basis. These sizes will be sent unless otherwise ordered.

Alignment. This face aligns with all 14-point one- and two-letter faces except German.

Will run in machines Nos. 2, 3, 4 and 5.

To avoid errors read notice on page six

SPECIMENS OF LINOTYPE FACES

14-POINT
CHELTENHAM
WITH
ITALIC AND
SMALL CAPS
Two-Letter

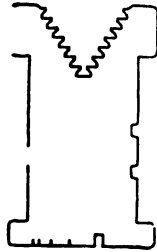

SPECIAL
CHARACTERS

á à â ä ç é è ê ë ì í î ï ñ ó ò ô ö ú û ü
 á à â ä ç é è ê ë ì í î ï ñ ó ò ô ö ú û ü

In Auxiliary Position.

Æ Œ

Æ Œ æ œ ct st Qu
 Æ Œ æ œ ct st Qu

One-Letter Matrices to be used for two-letter work.

§ ¶ || † ‡ - ¢ /
 $\frac{1}{3}$ $\frac{2}{3}$ $\frac{1}{5}$ $\frac{2}{5}$ $\frac{3}{5}$ $\frac{4}{5}$ $\frac{1}{6}$ $\frac{5}{6}$
 $\frac{1}{8}$ $\frac{1}{4}$ $\frac{3}{8}$ $\frac{1}{2}$ $\frac{5}{8}$ $\frac{3}{4}$ $\frac{7}{8}$ $\frac{1}{3}$ $\frac{2}{3}$ $\frac{1}{5}$ $\frac{2}{5}$ $\frac{3}{5}$ $\frac{4}{5}$ $\frac{1}{6}$ $\frac{5}{6}$

MERGENTHALER LINOTYPE CO.

6-POINT CLASSIC WITH ITALIC AND SMALL CAPS [TWO-LETTER]

Lower case alphabet 14.37 ems

THE MOST ancient materials employed for recording events were bricks, tiles, shells, and tablets of stone. The modes of writing upon these different substances were various. The tiles and brick were impressed with a stamp when in a soft state; the shells and tablets of stone were etched or graven, the figures or characters being cut in their surface, and in some cases also stained with various colors. It was by the ancient art of stamping that the walls, palaces, and towers of Babylon were covered with hieroglyphics, which have but recently been brought to light from under the immense mounds of Mesopotamia by Layard and other explorers. The patriarch Job, who is supposed to have lived about 2,300 years after the creation, exclaimed, "*O that my words were now written! O that they were printed in a book! that they were graven with an iron pen, and hid in the rock forever!*" Stung with the unjust accusation of his friends, he desires to record his words that the generations following might see the justice of his cause. The English translation has given the allusion to printing to the text, the original word signifying rather

THE MOST ancient materials employed for recording events were bricks, tiles, shells, and tables of stone. The modes of writing on these different substances were various. The tiles and brick were impressed with a stamp when in a soft state; the shells and tablets of stone were etched or graven the figures or characters being cut in their surface, and in some cases also stained with various colors. It was by the ancient art of stamping that the walls, palaces, and towers of Babylon were covered with hieroglyphics, which have but recently been brought to light from under the immense mounds of Mesopotamia by Layard and other explorers. The patriarch Job, who is supposed to have lived about 2,300 years after the creation, exclaimed, "*O that my words were now written! O that they were printed in a book! that they were graven with an iron pen, and hid in the rock forever!*" Stung with the unjust accusation of his friends, he desires to record his

ABCDEFGHIJKLMNOPQRSTUVWXYZ&
ABCDEFGHIJKLMNOPQRSTUVWXYZUN

abcdefghijklmnopqrstuvwxyz

abcdefghijklmnopqrstuvwxyz

1 2 3 4 5 6 7 8 9 0

V B C D E F G R T J

, . : ; ! ? (|) * ' ' - . . . ß ſ ſ ſ ſ æ œ ð £ \$

, . s ; ! ? A I Q O ' ' - - L . . . ſ Y ff W M K H ð £ P

In Auxiliary Position. One-Letter Matrices.

1 2 3 4 5 6 7 8 9 0 ſ ſ ſ \$: () Z & x z a @ [] ¼ ½ ¾ ¾ ¾ ¾

Special set table characters. Figures and figure space .0484; double figure space .0968; comma, period, and quotations .0277. Type foundry's point system. These sizes will be sent unless otherwise ordered.

Alignment. This face aligns with all 6-point one- and two-letter faces except German.

Will run in all machines.

To avoid errors read notice on page six

SPECIMENS OF LINOTYPE FACES

**6-POINT CLASSIC
WITH
ITALIC AND
SMALL CAPS
Two-Letter**

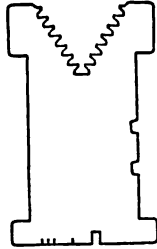

**SPECIAL
CHARACTERS**

á â ã ä å ç è é ê ë ì í î ï ñ ò ó ô õ ú û ü
 á â ã ä å ç è é ê ë ì í î ï ñ ò ó ô õ ú û ü

Æ æ Œ œ ﬀ W
 Æ æ Œ œ w W

Small Caps in Auxillary position
 Æ Œ

One-letter Matrices to be used for two-letter work

§ ¶ † ‡ || - " ' ° ¢ /

¼ ½ ¾ ⅓ ⅔ ⅖ ⅘ ⅙ ⅛ ¼ ⅜ ⅝ ⅞ ⅚ ⅛ ⅞ ⅝ ⅜ ¼ ⅓ ⅔ ¾

1234567890+-x abcdefghijklmnopqrstuvwxyz abcdefghijklmnopqrstuvwxyz 1234567890+-x

Superior: cm ns nk rv ð þ ñ ò . . . () ' ¨ † ‡ § Inferior: ()

abcdefghijklmnopqrstuvwxyz abcdefghijklmnopqrstuvwxyz

Piece Fractions—Upper half: ¼ ½ ¾ ⅓ ⅔ ⅖ ⅘ ⅙ ⅛ ⅜ ⅝ ⅞ ⅚ Lower half: ¼ ½ ¾ ⅓ ⅔ ⅖ ⅘ ⅙ ⅛ ⅜ ⅝ ⅞ ⅚

Plain Figures for Piece Fractions—Upper: 1234567890 Lower: 1234567890

⊙ ⊕ ⊗ ⊛ ⊜ ⊝ ⊞ ⊟ ⊠ ⊡ ⊢ ⊣ ⊤ ⊥ ⊦ ⊧ ⊨ ⊩ ⊪ ⊫ ⊬ ⊭ ⊮ ⊯ ⊰ ⊱ ⊲ ⊳ ⊴ ⊵ ⊶ ⊷ ⊸ ⊹ ⊺ ⊻ ⊼ ⊽ ⊾ ⊿ ⊿
 ♂ ♀ ♁ ♂ ♃ ♄ ♅ ♆ ♇ ♈ ♉ ♊ ♋ ♌ ♍ ♎ ♏ ♐ ♑ ♒ ♓ ♔ ♕ ♖ ♗ ♘ ♙ ♚ ♛ ♜ ♝ ♞ ♟ ♠ ♡ ♢ ♣ ♤ ♥ ♦ ♧ ♨ ♩ ♪ ♫ ♬ ♭ ♮ ♯ ♺ ♻ ♼ ♽ ♾ ♿
 ♂ ♀ ♁ ♂ ♃ ♄ ♅ ♆ ♇ ♈ ♉ ♊ ♋ ♌ ♍ ♎ ♏ ♐ ♑ ♒ ♓ ♔ ♕ ♖ ♗ ♘ ♙ ♚ ♛ ♜ ♝ ♞ ♟ ♠ ♡ ♢ ♣ ♤ ♥ ♦ ♧ ♨ ♩ ♪ ♫ ♬ ♭ ♮ ♯ ♺ ♻ ♼ ♽ ♾ ♿
 ♂ ♀ ♁ ♂ ♃ ♄ ♅ ♆ ♇ ♈ ♉ ♊ ♋ ♌ ♍ ♎ ♏ ♐ ♑ ♒ ♓ ♔ ♕ ♖ ♗ ♘ ♙ ♚ ♛ ♜ ♝ ♞ ♟ ♠ ♡ ♢ ♣ ♤ ♥ ♦ ♧ ♨ ♩ ♪ ♫ ♬ ♭ ♮ ♯ ♺ ♻ ♼ ♽ ♾ ♿
 ♂ ♀ ♁ ♂ ♃ ♄ ♅ ♆ ♇ ♈ ♉ ♊ ♋ ♌ ♍ ♎ ♏ ♐ ♑ ♒ ♓ ♔ ♕ ♖ ♗ ♘ ♙ ♚ ♛ ♜ ♝ ♞ ♟ ♠ ♡ ♢ ♣ ♤ ♥ ♦ ♧ ♨ ♩ ♪ ♫ ♬ ♭ ♮ ♯ ♺ ♻ ♼ ♽ ♾ ♿

MERGENTHALER LINOTYPE CO.

8-POINT CLASSIC WITH ITALIC AND SMALL CAPS
[TWO-LETTER]

Lower case alphabet 14.06 ems

THE MOST ancient materials employed for recording events were bricks, tiles, shells, and tables of stone. *The modes of writing on these different substances were various.* The tiles and brick were impressed with a stamp when in a soft state; the shells and tablets of stone were etched or graven, the figures or characters being cut in their surface, and in some cases also stained with various colors. It was by the ancient art of stamping that the walls, palaces, and towers of Babylon were covered with hieroglyphics, which have but recently been brought to light from under the immense mounds of

THE MOST ancient materials employed for recording events were bricks, tiles, shells, and tables of stone. The modes of writing on these different substances were etched or graven, the figures or impressed with a stamp when in a soft state; the shells and tablets of stone were etched or graven, the figures or characters being cut in their surface, and in some cases also stained with various colors. It was by the ancient art of stamping that the walls, palaces, and towers of Babylon were covered with

ABCDEFGHIJKLMN OPQRSTUVWXYZ &
ABCDEFGHIJKLMN OPQRSTUVWXYZ UN

abcdefghijklmnopqrstuvwxy z
abcdefghijklmnopqrstuvwxy z

1 2 3 4 5 6 7 8 9 0

V B C D E F G R T J

, . : ; ! ? (|) * ' ' - — . . . fl fl fl fl fl æ œ ð £ \$
, . s ; / P A I Q O ' ' - — L . . . fl Y ff W M K H ð £ P

In Auxilliary Position.

1 2 3 4 5 6 7 8 9 0 fl ffi ffi \$ Z & : () x z &

One-Letter Matrices

@ [] 1/8 1/4 3/8 1/2 5/8 3/4 7/8

Special set table characters. Figures and figure space .06225; em space .1245; comma, period, and quotations .0311. Type foundery's point system. These sizes will be sent unless otherwise ordered.

Alignment. This face aligns with all 8-point one- and two-letter faces having low alignment except German.

Will run in all machines.

To avoid errors read notice on page six

MERGENTHALER LINOTYPE CO.

10-POINT CLASSIC WITH ITALIC AND SMALL CAPS
[TWO-LETTER]

Lower case alphabet 12.22 ems

THE MOST ancient materials used for recording events were bricks, tiles, shells, and tables of stone. *The modes of writing on these different substances were various.* The tiles and brick were impressed with a stamp when in a soft state; the shells and tablets of stone were etched or graven, the figures or characters being cut in their surface, and in some cases also stained with various colors. It was by the ancient art of stamping that the walls, palaces, and towers of Babylon were covered with hiero-

THE MOST ancient materials used for recording events were bricks, tiles, shells, and tables of stone. The modes of writing on these different substances were various. The tiles and brick were impressed with a stamp when in a soft state; the shells and tablets of stone were etched or graven, the figures or characters being cut in their surface, and

ABCDEFGHIJKLMN OPQRSTUVWXYZ &
ABCDEFGHIJKLMN OPQRSTUVWXYZ UN

abcdefghijklmnopqrstuvwxy z
abcdefghijklmnopqrstuvwxy z

1 2 3 4 5 6 7 8 9 0

V B C D E F G R T J

, . : ; ! ? (|) * ' ' - — . . . fi fl ffi ffi ffi æ œ ð £ \$
, . s ; ! ? A I Q O ' ' - — L . . . fi Y ff W M K H ð £ P

Duplicate Character Matrices

1 2 3 4 5 6 7 8 9 0 fl ffi ffi \$ Z & : () x z &

One-Letter Matrices

@ [] 1/8 1/4 3/8 1/2 5/8 3/4 7/8

True set table characters. Figures and en quad .0691; em quad .1383; comma, period, and quotations .0345. These sizes will be sent unless otherwise ordered.

Alignment. This face aligns with all 10-point one- and two-letter faces except German.

Will run in all machines.

To avoid errors read notice on page six

MERGENTHALER LINOTYPE CO.

12-POINT CLASSIC WITH ITALIC AND SMALL CAPS
[TWO-LETTER]

Lower case alphabet 12.73 ems

THE MOST ancient materials used for recording events were bricks, tiles, shells, and tables of stone. *The modes of writing on these different substances were various.* The tiles and brick were impressed with a stamp when in a soft state; the shells and tablets of stone were etched or graven, the figures or characters being cut in their surface, and in some cases

THE MOST ancient materials used for recording events were bricks, tiles, shells, and tables of stone. The modes of writing on these different substances were various. The tiles and brick were impressed with a stamp when in a soft .

ABCDEFGHIJKLMN OPQRSTUVWXYZ &
ABCDEFGHIJKLMN OPQRSTUVWXYZ UN
abcdefghijklmnopqrstuvwxyz
abcdefghijklmnopqrstuvwxyz

1 2 3 4 5 6 7 8 9 0

V B C D E F G R T J

, . : ; ! ? (|) * ' " — . . . fi fl ff ffi ffl æ œ ð £ \$
, . S ; ! ? A I Q O ' " — L . . . fi Y ff W M K H ð £ P

Duplicate Character Matrices.

1 2 3 4 5 6 7 8 9 0 fl ffi ffl \$ Z & : () X Z &

One-Letter Matrices

@ [] 1/8 1/4 3/8 1/2 5/8 3/4 7/8

Special set table characters. Figures and figure space .090; double figure space .180; comma, period, and quotations .045. These sizes will be sent unless otherwise ordered.

Alignment. This face aligns with all 12-point one- and two-letter faces except German.

Will run in machines Nos. 2, 3, 4 and 5.

To avoid errors read notice on page six

MERGENTHALER LINOTYPE CO.

14-POINT NO. 36 WITH ITALIC AND SMALL CAPS

[TWO-LETTER]

Lower case alphabet 11.30 ems

THE MOST ancient materials employed for recording events were bricks, tiles, shells, and tables of stone. *The modes of writing on these different substances were various.* The tiles and brick were impressed with a stamp when in a soft state; the shells and

THE MOST ancient materials used for recording events were bricks, tiles, shells, and tables of stone. The modes of writing on these different substances were many. The bricks were impressed with

ABCDEFGHIJKLMN^OPQRSTU^VWXY^Z&
 ABCDEFGHIJKLMN^OPQRSTU^VWXY^ZUN
 abcdefghijklmnopqrstu^vwxyz
 abcdefghijklmnopqrstu^vwxyz
 1 2 3 4 5 6 7 8 9 0
 V B C D E F G R T J

, . : ; ! ? (|) * ' — . . . fi ff ffi ffl æ œ ð £ \$
 , . S ; ! ? A I Q O ' — L . . . fi Y ff W M K H ð £ P
 1 2 3 4 5 6 7 8 9 0 fl ffi ffl \$ Z & : () X Z &
 @ [] 1/8 1/4 3/8 1/2 5/8 3/4 7/8

True set table characters. Figures and en quad .098; em quad .196; comma, period, and quotations .049. These sizes will we sent unless otherwise ordered.

Alignment: This face aligns with all 14-point one- and two-letter faces except German.

Will run in machines Nos. 2, 3, 4 and 5.

To avoid errors read notice on page six

SPECIMENS OF LINOTYPE FACES

14-POINT NO. 36
 WITH
 ITALIC AND
 SMALL CAPS
 Two-Letter

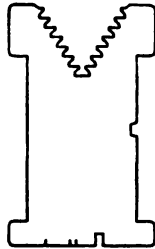

SPECIAL
 CHARACTERS

á à â ä ç è é ê ë ì í î ï ñ ó ò ô õ ú û ü
 á à â ä ç è é ê ë ì í î ï ñ ó ò ô õ ú û ü

Æ æ Œ œ
Æ æ Œ œ

Duplicate Character Matrices.

Æ Œ œ œ

One-Letter Matrices to be used for two-letter work.



§ ¶ || † ‡ - /

$\frac{1}{3}$ $\frac{2}{3}$ $\frac{1}{5}$ $\frac{2}{5}$ $\frac{3}{5}$ $\frac{4}{5}$ $\frac{1}{6}$ $\frac{5}{6}$

$\frac{1}{3}$ $\frac{2}{3}$ $\frac{1}{5}$ $\frac{2}{5}$ $\frac{3}{5}$ $\frac{4}{5}$ $\frac{1}{6}$ $\frac{5}{6}$ $\frac{1}{8}$ $\frac{3}{8}$ $\frac{1}{2}$ $\frac{5}{8}$ $\frac{3}{4}$ $\frac{7}{8}$

MERGENTHALER LINOTYPE CO.

14-POINT CONGRESSIONAL ROMAN PLAIN AND CANCELLED
[TWO-LETTER]

Lower case alphabet 11.39 ems

The most ancient materials employed for recording events were bricks, tiles, shells, and tables of stone. The modes of writing on these different substances were various. The tiles and brick were impressed with a stamp when in a soft state; the shells and tablets of

The most ancient materials used for recording events were bricks, tiles, shells, and tables of stone. The modes of writing on these different substances were many. The

ABCDEFGHIJKLMN OPQRSTUVWXYZ &
~~ABCDEFGHIJKLMN OPQRSTUVWXYZ &~~

abcdefghijklmnopqrstuvwxy
~~abcdefghijklmnopqrstuvwxy~~

1 2 3 4 5 6 7 8 9 0
~~1 2 3 4 5 6 7 8 9 0~~

, . : ; ! ? (|) * ' ' — . . . fi fi ff ffi ffl lb @ £ \$ []
~~, . : ; ! ? (|) * ' ' — . . . fi fi ff ffi ffl lb @ £ \$ []~~

$\frac{1}{8}$ $\frac{1}{4}$ $\frac{3}{8}$ $\frac{1}{2}$ $\frac{5}{8}$ $\frac{3}{4}$ $\frac{7}{8}$
 ~~$\frac{1}{8}$ $\frac{1}{4}$ $\frac{3}{8}$ $\frac{1}{2}$ $\frac{5}{8}$ $\frac{3}{4}$ $\frac{7}{8}$~~

True set table characters. Figures and en quad .098; em quad .196; comma, period, and quotations .049. These sizes will be sent unless otherwise ordered.

Alignment. This face aligns with all 14-point one- and two-letter faces except German.

Will run in machines Nos. 2, 3, 4 and 5.

To avoid errors read notice on page six

SPECIMENS OF LINOTYPE FACES

14-POINT
CONGRESSIONAL
ROMAN
PLAIN AND
CANCELLED
Two-Letter

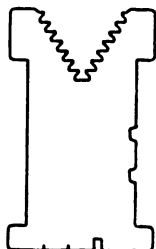

SPECIAL
CHARACTERS

á à â ä ç é è ê ë ì ï ï ï ñ ó ò ô ö ú û ü
 à â â ä ç é è ê ë ì ï ï ï ñ ó ò ô ö ú û ü

Æ æ Œ œ

Æ æ Œ œ - - —

$\frac{1}{3}$ $\frac{2}{3}$ $\frac{1}{5}$ $\frac{2}{5}$ $\frac{3}{5}$ $\frac{4}{5}$ $\frac{1}{6}$ $\frac{5}{6}$

$\frac{1}{3}$ $\frac{2}{3}$ $\frac{1}{5}$ $\frac{2}{5}$ $\frac{3}{5}$ $\frac{4}{5}$ $\frac{1}{6}$ $\frac{5}{6}$

§ ¶ || † ‡ ™ ™ / % - “ ” ’ ’ ° ()

§ ¶ || † ‡ ™ ™ / % - “ ” ’ ’ ° ()

MERGENTHALER LINOTYPE CO.

14-POINT CONGRESSIONAL ITALIC PLAIN AND CANCELLED
[TWO-LETTER]

Lower case alphabet 11.14 ems

The most ancient materials employed for recording events were bricks, tiles, shells, and tables of stone. The modes of writing on these different substances were various. The tiles and brick were impressed with a stamp when in a soft state; the shells and tablets of stone were etched or graven, the figures or

The most ancient materials used for recording events were bricks, tiles, shells, and tables of stone. The modes of writing on these different substances were many. The bricks were impressed with

ABCDEFGHIJKLMNOPQRSTUVWXYZ
~~ABCDEFGHIJKLMNOPQRSTUVWXYZ~~

abcdefghijklmnopqrstuvwxy
~~abcdefghijklmnopqrstuvwxy~~

1 2 3 4 5 6 7 8 9 0
~~1 2 3 4 5 6 7 8 9 0~~

̄ ̇ ̈ ̉ ̊ ̋ ̌ ̍ ̎ ̏ ̐ ̑ ̒ ̓ ̔ ̕ ̖ ̗ ̘ ̙ ̚ ̛ ̜ ̝ ̞ ̟ ̠ ̡ ̢ ̣ ̤ ̥ ̦ ̧ ̨ ̩ ̪ ̫ ̬ ̭ ̮ ̯ ̰ ̱ ̲ ̳ ̴ ̵ ̶ ̷ ̸ ̹ ̺ ̻ ̼ ̽ ̾ ̿ ̺̄ ̻̄ ̼̄ ̽̄ ̾̄ ̿̄ ̺̅ ̻̅ ̼̅ ̽̅ ̾̅ ̿̅ ̺̆ ̻̆ ̼̆ ̽̆ ̾̆ ̿̆ ̺̇ ̻̇ ̼̇ ̽̇ ̾̇ ̿̇ ̺̈ ̻̈ ̼̈ ̽̈ ̾̈ ̿̈ ̺̉ ̻̉ ̼̉ ̽̉ ̾̉ ̿̉ ̺̊ ̻̊ ̼̊ ̽̊ ̾̊ ̿̊ ̺̋ ̻̋ ̼̋ ̽̋ ̾̋ ̿̋ ̺̌ ̻̌ ̼̌ ̽̌ ̾̌ ̿̌ ̺̍ ̻̍ ̼̍ ̽̍ ̾̍ ̿̍ ̺̎ ̻̎ ̼̎ ̽̎ ̾̎ ̿̎ ̺̏ ̻̏ ̼̏ ̽̏ ̾̏ ̿̏ ̺̐ ̻̐ ̼̐ ̽̐ ̾̐ ̿̐ ̺̑ ̻̑ ̼̑ ̽̑ ̾̑ ̿̑ ̺̒ ̻̒ ̼̒ ̽̒ ̾̒ ̿̒ ̺̓ ̻̓ ̼̓ ̽̓ ̾̓ ̿̓ ̺̔ ̻̔ ̼̔ ̽̔ ̾̔ ̿̔ ̺̕ ̻̕ ̼̕ ̽̕ ̾̕ ̿̕ ̺̖ ̻̖ ̼̖ ̖̽ ̖̾ ̖̿ ̺̗ ̻̗ ̼̗ ̗̽ ̗̾ ̗̿ ̺̘ ̻̘ ̼̘ ̘̽ ̘̾ ̘̿ ̺̙ ̻̙ ̼̙ ̙̽ ̙̾ ̙̿ ̺̚ ̻̚ ̼̚ ̽̚ ̾̚ ̿̚ ̛̺ ̛̻ ̛̼ ̛̽ ̛̾ ̛̿ ̺̜ ̻̜ ̼̜ ̜̽ ̜̾ ̜̿ ̺̝ ̻̝ ̼̝ ̝̽ ̝̾ ̝̿ ̺̞ ̻̞ ̼̞ ̞̽ ̞̾ ̞̿ ̺̟ ̻̟ ̼̟ ̟̽ ̟̾ ̟̿ ̺̠ ̻̠ ̼̠ ̠̽ ̠̾ ̠̿ ̡̺ ̡̻ ̡̼ ̡̽ ̡̾ ̡̿ ̢̺ ̢̻ ̢̼ ̢̽ ̢̾ ̢̿ ̺̣ ̻̣ ̼̣ ̣̽ ̣̾ ̣̿ ̺̤ ̻̤ ̼̤ ̤̽ ̤̾ ̤̿ ̺̥ ̻̥ ̼̥ ̥̽ ̥̾ ̥̿ ̺̦ ̻̦ ̼̦ ̦̽ ̦̾ ̦̿ ̧̺ ̧̻ ̧̼ ̧̽ ̧̾ ̧̿ ̨̺ ̨̻ ̨̼ ̨̽ ̨̾ ̨̿ ̺̩ ̻̩ ̼̩ ̩̽ ̩̾ ̩̿ ̺̪ ̻̪ ̼̪ ̪̽ ̪̾ ̪̿ ̺̫ ̻̫ ̼̫ ̫̽ ̫̾ ̫̿ ̺̬ ̻̬ ̼̬ ̬̽ ̬̾ ̬̿ ̺̭ ̻̭ ̼̭ ̭̽ ̭̾ ̭̿ ̺̮ ̻̮ ̼̮ ̮̽ ̮̾ ̮̿ ̺̯ ̻̯ ̼̯ ̯̽ ̯̾ ̯̿ ̺̰ ̻̰ ̼̰ ̰̽ ̰̾ ̰̿ ̺̱ ̻̱ ̼̱ ̱̽ ̱̾ ̱̿ ̺̲ ̻̲ ̼̲ ̲̽ ̲̾ ̲̿ ̺̳ ̻̳ ̼̳ ̳̽ ̳̾ ̳̿ ̴̺ ̴̻ ̴̼ ̴̽ ̴̾ ̴̿ ̵̺ ̵̻ ̵̼ ̵̽ ̵̾ ̵̿ ̶̺ ̶̻ ̶̼ ̶̽ ̶̾ ̶̿ ̷̺ ̷̻ ̷̼ ̷̽ ̷̾ ̷̿ ̸̺ ̸̻ ̸̼ ̸̽ ̸̾ ̸̿ ̺̹ ̻̹ ̼̹ ̹̽ ̹̾ ̹̿ ̺̺ ̻̺ ̼̺ ̺̽ ̺̾ ̺̿ ̺̻ ̻̻ ̼̻ ̻̽ ̻̾ ̻̿ ̺̼ ̻̼ ̼̼ ̼̽ ̼̾ ̼̿ ̺̽ ̻̽ ̼̽ ̽̽ ̾̽ ̿̽ ̺̾ ̻̾ ̼̾ ̽̾ ̾̾ ̿̾ ̺̿ ̻̿ ̼̿ ̽̿ ̾̿ ̿̿ ̺̺̄ ̻̺̄ ̼̺̄ ̺̽̄ ̺̾̄ ̺̿̄ ̺̺̅ ̻̺̅ ̼̺̅ ̺̽̅ ̺̾̅ ̺̿̅ ̺̺̆ ̻̺̆ ̼̺̆ ̺̽̆ ̺̾̆ ̺̿̆ ̺̺̇ ̻̺̇ ̼̺̇ ̺̽̇ ̺̾̇ ̺̿̇ ̺̺̈ ̻̺̈ ̼̺̈ ̺̽̈ ̺̾̈ ̺̿̈ ̺̺̉ ̻̺̉ ̼̺̉ ̺̽̉ ̺̾̉ ̺̿̉ ̺̺̊ ̻̺̊ ̼̺̊ ̺̽̊ ̺̾̊ ̺̿̊ ̺̺̋ ̻̺̋ ̼̺̋ ̺̽̋ ̺̾̋ ̺̿̋ ̺̺̌ ̻̺̌ ̼̺̌ ̺̽̌ ̺̾̌ ̺̿̌ ̺̺̍ ̻̺̍ ̼̺̍ ̺̽̍ ̺̾̍ ̺̿̍ ̺̺̎ ̻̺̎ ̼̺̎ ̺̽̎ ̺̾̎ ̺̿̎ ̺̺̏ ̻̺̏ ̼̺̏ ̺̽̏ ̺̾̏ ̺̿̏ ̺̺̐ ̻̺̐ ̼̺̐ ̺̽̐ ̺̾̐ ̺̿̐ ̺̺̑ ̻̺̑ ̼̺̑ ̺̽̑ ̺̾̑ ̺̿̑ ̺̺̒ ̻̺̒ ̼̺̒ ̺̽̒ ̺̾̒ ̺̿̒ ̺̺̓ ̻̺̓ ̼̺̓ ̺̽̓ ̺̾̓ ̺̿̓ ̺̺̔ ̻̺̔ ̼̺̔ ̺̽̔ ̺̾̔ ̺̿̔ ̺̺̕ ̻̺̕ ̼̺̕ ̺̽̕ ̺̾̕ ̺̿̕ ̺̺̖ ̻̺̖ ̼̺̖ ̺̖̽ ̺̖̾ ̺̖̿ ̺̺̗ ̻̺̗ ̼̺̗ ̺̗̽ ̺̗̾ ̺̗̿ ̺̺̘ ̻̺̘ ̼̺̘ ̺̘̽ ̺̘̾ ̺̘̿ ̺̺̙ ̻̺̙ ̼̺̙ ̺̙̽ ̺̙̾ ̺̙̿ ̺̺̚ ̻̺̚ ̼̺̚ ̺̽̚ ̺̾̚ ̺̿̚ ̛̺̺ ̛̻̺ ̛̼̺ ̛̺̽ ̛̺̾ ̛̺̿ ̺̺̜ ̻̺̜ ̼̺̜ ̺̜̽ ̺̜̾ ̺̜̿ ̺̺̝ ̻̺̝ ̼̺̝ ̺̝̽ ̺̝̾ ̺̝̿ ̺̺̞ ̻̺̞ ̼̺̞ ̺̞̽ ̺̞̾ ̺̞̿ ̺̺̟ ̻̺̟ ̼̺̟ ̺̟̽ ̺̟̾ ̺̟̿ ̺̺̠ ̻̺̠ ̼̺̠ ̺̠̽ ̺̠̾ ̺̠̿ ̡̺̺ ̡̻̺ ̡̼̺ ̡̺̽ ̡̺̾ ̡̺̿ ̢̺̺ ̢̻̺ ̢̼̺ ̢̺̽ ̢̺̾ ̢̺̿ ̺̺̣ ̻̺̣ ̼̺̣ ̺̣̽ ̺̣̾ ̺̣̿ ̺̺̤ ̻̺̤ ̼̺̤ ̺̤̽ ̺̤̾ ̺̤̿ ̺̺̥ ̻̺̥ ̼̺̥ ̺̥̽ ̺̥̾ ̺̥̿ ̺̺̦ ̻̺̦ ̼̺̦ ̺̦̽ ̺̦̾ ̺̦̿ ̧̺̺ ̧̻̺ ̧̼̺ ̧̺̽ ̧̺̾ ̧̺̿ ̨̺̺ ̨̻̺ ̨̼̺ ̨̺̽ ̨̺̾ ̨̺̿ ̺̺̩ ̻̺̩ ̼̺̩ ̺̩̽ ̺̩̾ ̺̩̿ ̺̺̪ ̻̺̪ ̼̺̪ ̺̪̽ ̺̪̾ ̺̪̿ ̺̺̫ ̻̺̫ ̼̺̫ ̺̫̽ ̺̫̾ ̺̫̿ ̺̺̬ ̻̺̬ ̼̺̬ ̺̬̽ ̺̬̾ ̺̬̿ ̺̺̭ ̻̺̭ ̼̺̭ ̺̭̽ ̺̭̾ ̺̭̿ ̺̺̮ ̻̺̮ ̼̺̮ ̺̮̽ ̺̮̾ ̺̮̿ ̺̺̯ ̻̺̯ ̼̺̯ ̺̯̽ ̺̯̾ ̺̯̿ ̺̺̰ ̻̺̰ ̼̺̰ ̺̰̽ ̺̰̾ ̺̰̿ ̺̺̱ ̻̺̱ ̼̺̱ ̺̱̽ ̺̱̾ ̺̱̿ ̺̺̲ ̻̺̲ ̼̺̲ ̺̲̽ ̺̲̾ ̺̲̿ ̺̺̳ ̻̺̳ ̼̺̳ ̺̳̽ ̺̳̾ ̺̳̿ ̴̺̺ ̴̻̺ ̴̼̺ ̴̺̽ ̴̺̾ ̴̺̿ ̵̺̺ ̵̻̺ ̵̼̺ ̵̺̽ ̵̺̾ ̵̺̿ ̶̺̺ ̶̻̺ ̶̼̺ ̶̺̽ ̶̺̾ ̶̺̿ ̷̺̺ ̷̻̺ ̷̼̺ ̷̺̽ ̷̺̾ ̷̺̿ ̸̺̺ ̸̻̺ ̸̼̺ ̸̺̽ ̸̺̾ ̸̺̿ ̺̺̹ ̻̺̹ ̼̺̹ ̺̹̽ ̺̹̾ ̺̹̿ ̺̺̺ ̻̺̺ ̼̺̺ ̺̺̽ ̺̺̾ ̺̺̿ ̺̺̻ ̻̺̻ ̼̺̻ ̺̻̽ ̺̻̾ ̺̻̿ ̺̺̼ ̻̺̼ ̼̺̼ ̺̼̽ ̺̼̾ ̺̼̿ ̺̺̽ ̻̺̽ ̼̺̽ ̺̽̽ ̺̾̽ ̺̿̽ ̺̺̾ ̻̺̾ ̼̺̾ ̺̽̾ ̺̾̾ ̺̿̾ ̺̺̿ ̻̺̿ ̼̺̿ ̺̽̿ ̺̾̿ ̺̿̿ ̺̺̺̄ ̻̺̺̄ ̼̺̺̄ ̺̺̽̄ ̺̺̾̄ ̺̺̿̄ ̺̺̺̅ ̻̺̺̅ ̼̺̺̅ ̺̺̽̅ ̺̺̾̅ ̺̺̿̅ ̺̺̺̆ ̻̺̺̆ ̼̺̺̆ ̺̺̽̆ ̺̺̾̆ ̺̺̿̆ ̺̺̺̇ ̻̺̺̇ ̼̺̺̇ ̺̺̽̇ ̺̺̾̇ ̺̺̿̇ ̺̺̺̈ ̻̺̺̈ ̼̺̺̈ ̺̺̽̈ ̺̺̾̈ ̺̺̿̈ ̺̺̺̉ ̻̺̺̉ ̼̺̺̉ ̺̺̽̉ ̺̺̾̉ ̺̺̿̉ ̺̺̺̊ ̻̺̺̊ ̼̺̺̊ ̺̺̽̊ ̺̺̾̊ ̺̺̿̊ ̺̺̺̋ ̻̺̺̋ ̼̺̺̋ ̺̺̽̋ ̺̺̾̋ ̺̺̿̋ ̺̺̺̌ ̻̺̺̌ ̼̺̺̌ ̺̺̽̌ ̺̺̾̌ ̺̺̿̌ ̺̺̺̍ ̻̺̺̍ ̼̺̺̍ ̺̺̽̍ ̺̺̾̍ ̺̺̿̍ ̺̺̺̎ ̻̺̺̎ ̼̺̺̎ ̺̺̽̎ ̺̺̾̎ ̺̺̿̎ ̺̺̺̏ ̻̺̺̏ ̼̺̺̏ ̺̺̽̏ ̺̺̾̏ ̺̺̿̏ ̺̺̺̐ ̻̺̺̐ ̼̺̺̐ ̺̺̽̐ ̺̺̾̐ ̺̺̿̐ ̺̺̺̑ ̻̺̺̑ ̼̺̺̑ ̺̺̽̑ ̺̺̾̑ ̺̺̿̑ ̺̺̺̒ ̻̺̺̒ ̼̺̺̒ ̺̺̽̒ ̺̺̾̒ ̺̺̿̒ ̺̺̺̓ ̻̺̺̓ ̼̺̺̓ ̺̺̽̓ ̺̺̾̓ ̺̺̿̓ ̺̺̺̔ ̻̺̺̔ ̼̺̺̔ ̺̺̽̔ ̺̺̾̔ ̺̺̿̔ ̺̺̺̕ ̻̺̺̕ ̼̺̺̕ ̺̺̽̕ ̺̺̾̕ ̺̺̿̕ ̺̺̺̖ ̻̺̺̖ ̼̺̺̖ ̺̺̖̽ ̺̺̖̾ ̺̺̖̿ ̺̺̺̗ ̻̺̺̗ ̼̺̺̗ ̺̺̗̽ ̺̺̗̾ ̺̺̗̿ ̺̺̺̘ ̻̺̺̘ ̼̺̺̘ ̺̺̘̽ ̺̺̘̾ ̺̺̘̿ ̺̺̺̙ ̻̺̺̙ ̼̺̺̙ ̺̺̙̽ ̺̺̙̾ ̺̺̙̿ ̺̺̺̚ ̻̺̺̚ ̼̺̺̚ ̺̺̽̚ ̺̺̾̚ ̺̺̿̚ ̛̺̺̺ ̛̻̺̺ ̛̼̺̺ ̛̺̺̽ ̛̺̺̾ ̛̺̺̿ ̺̺̺̜ ̻̺̺̜ ̼̺̺̜ ̺̺̜̽ ̺̺̜̾ ̺̺̜̿ ̺̺̺̝ ̻̺̺̝ ̼̺̺̝ ̺̺̝̽ ̺̺̝̾ ̺̺̝̿ ̺̺̺̞ ̻̺̺̞ ̼̺̺̞ ̺̺̞̽ ̺̺̞̾ ̺̺̞̿ ̺̺̺̟ ̻̺̺̟ ̼̺̺̟ ̺̺̟̽ ̺̺̟̾ ̺̺̟̿ ̺̺̺̠ ̻̺̺̠ ̼̺̺̠ ̺̺̠̽ ̺̺̠̾ ̺̺̠̿ ̡̺̺̺ ̡̻̺̺ ̡̼̺̺ ̡̺̺̽ ̡̺̺̾ ̡̺̺̿ ̢̺̺̺ ̢̻̺̺ ̢̼̺̺ ̢̺̺̽ ̢̺̺̾ ̢̺̺̿ ̺̺̺̣ ̻̺̺̣ ̼̺̺̣ ̺̺̣̽ ̺̺̣̾ ̺̺̣̿ ̺̺̺̤ ̻̺̺̤ ̼̺̺̤ ̺̺̤̽ ̺̺̤̾ ̺̺̤̿ ̺̺̺̥ ̻̺̺̥ ̼̺̺̥ ̺̺̥̽ ̺̺̥̾ ̺̺̥̿ ̺̺̺̦ ̻̺̺̦ ̼̺̺̦ ̺̺̦̽ ̺̺̦̾ ̺̺̦̿ ̧̺̺̺ ̧̻̺̺ ̧̼̺̺ ̧̺̺̽ ̧̺̺̾ ̧̺̺̿ ̨̺̺̺ ̨̻̺̺ ̨̼̺̺ ̨̺̺̽ ̨̺̺̾ ̨̺̺̿ ̺̺̺̩ ̻̺̺̩ ̼̺̺̩ ̺̺̩̽ ̺̺̩̾ ̺̺̩̿ ̺̺̺̪ ̻̺̺̪ ̼̺̺̪ ̺̺̪̽ ̺̺̪̾ ̺̺̪̿ ̺̺̺̫ ̻̺̺̫ ̼̺̺̫ ̺̺̫̽ ̺̺̫̾ ̺̺̫̿ ̺̺̺̬ ̻̺̺̬ ̼̺̺̬ ̺̺̬̽ ̺̺̬̾ ̺̺̬̿ ̺̺̺̭ ̻̺̺̭ ̼̺̺̭ ̺̺̭̽ ̺̺̭̾ ̺̺̭̿ ̺̺̺̮ ̻̺̺̮ ̼̺̺̮ ̺̺̮̽ ̺̺̮̾ ̺̺̮̿ ̺̺̺̯ ̻̺̺̯ ̼̺̺̯ ̺̺̯̽ ̺̺̯̾ ̺̺̯̿ ̺̺̺̰ ̻̺̺̰ ̼̺̺̰ ̺̺̰̽ ̺̺̰̾ ̺̺̰̿ ̺̺̺̱ ̻̺̺̱ ̼̺̺̱ ̺̺̱̽ ̺̺̱̾ ̺̺̱̿ ̺̺̺̲ ̻̺̺̲ ̼̺̺̲ ̺̺̲̽ ̺̺̲̾ ̺̺̲̿ ̺̺̺̳ ̻̺̺̳ ̼̺̺̳ ̺̺̳̽ ̺̺̳̾ ̺̺̳̿ ̴̺̺̺ ̴̻̺̺ ̴̼̺̺ ̴̺̺̽ ̴̺̺̾ ̴̺̺̿ ̵̺̺̺ ̵̻̺̺ ̵̼̺̺ ̵̺̺̽ ̵̺̺̾ ̵̺̺̿ ̶̺̺̺ ̶̻̺̺ ̶̼̺̺ ̶̺̺̽ ̶̺̺̾ ̶̺̺̿ ̷̺̺̺ ̷̻̺̺ ̷̼̺̺ ̷̺̺̽ ̷̺̺̾ ̷̺̺̿ ̸̺̺̺ ̸̻̺̺ ̸̼̺̺ ̸̺̺̽ ̸̺̺̾ ̸̺̺̿ ̺̺̺̹ ̻̺̺̹ ̼̺̺̹ ̺̺̹̽ ̺̺̹̾ ̺̺̹̿ ̺̺̺̺ ̻̺̺̺ ̼̺̺̺ ̺̺̺̽ ̺̺̺̾ ̺̺̺̿ ̺̺̺̻ ̻̺̺̻ ̼̺̺̻ ̺̺̻̽ ̺̺̻̾ ̺̺̻̿ ̺̺̺̼ ̻̺̺̼ ̼̺̺̼ ̺̺̼̽ ̺̺̼̾ ̺̺̼̿ ̺̺̺̽ ̻̺̺̽ ̼̺̺̽ ̺̺̽̽ ̺̺̾̽ ̺̺̿̽ ̺̺̺̾ ̻̺̺̾ ̼̺̺̾ ̺̺̽̾ ̺̺̾̾ ̺̺̿̾ ̺̺̺̿ ̻̺̺̿ ̼̺̺̿ ̺̺̽̿ ̺̺̾̿ ̺̺̿̿ ̺̺̺̺̄ ̻̺̺̺̄ ̼̺̺̺̄ ̺̺̺̽̄ ̺̺̺̾̄ ̺̺̺̿̄ ̺̺̺̺̅ ̻̺̺̺̅ ̼̺̺̺̅ ̺̺̺̽̅ ̺̺̺̾̅ ̺̺̺̿̅ ̺̺̺̺̆ ̻̺̺̺̆ ̼̺̺̺̆ ̺̺̺̽̆ ̺̺̺̾̆ ̺̺̺̿̆ ̺̺̺̺̇ ̻̺̺̺̇ ̼̺̺̺̇ ̺̺̺̽̇ ̺̺̺̾̇ ̺̺̺̿̇ ̺̺̺̺̈ ̻̺̺̺̈ ̼̺̺̺̈ ̺̺̺̽̈ ̺̺̺̾̈ ̺̺̺̿̈ ̺̺̺̺̉ ̻̺̺̺̉ ̼̺̺̺̉ ̺̺̺̽̉ ̺̺̺̾̉ ̺̺̺̿̉ ̺̺̺̺̊ ̻̺̺̺̊ ̼̺̺̺̊ ̺̺̺̽̊ ̺̺̺̾̊ ̺̺̺̿̊ ̺̺̺̺̋ ̻̺̺̺̋ ̼̺̺̺̋ ̺̺̺̽̋ ̺̺̺̾̋ ̺̺̺̿̋ ̺̺̺̺̌ ̻̺̺̺̌ ̼̺̺̺̌ ̺̺̺̽̌ ̺̺̺̾̌ ̺̺̺̿̌ ̺̺̺̺̍ ̻̺̺̺̍ ̼̺̺̺̍ ̺̺̺̽̍ ̺̺̺̾̍ ̺̺̺̿̍ ̺̺̺̺̎ ̻̺̺̺̎ ̼̺̺̺̎ ̺̺̺̽̎ ̺̺̺̾̎ ̺̺̺̿̎ ̺̺̺̺̏ ̻̺̺̺̏ ̼̺̺̺̏ ̺̺̺̽̏ ̺̺̺̾̏ ̺̺̺̿̏ ̺̺̺̺̐ ̻̺̺̺̐ ̼̺̺̺̐ ̺̺̺̽̐ ̺̺̺̾̐ ̺̺̺̿̐ ̺̺̺̺̑ ̻̺̺̺̑ ̼̺̺̺̑ ̺̺̺̽̑ ̺̺̺̾̑ ̺̺̺̿̑ ̺̺̺̺̒ ̻̺̺̺̒ ̼̺̺̺̒ ̺̺̺̽̒ ̺̺̺̾̒ ̺̺̺̿̒ ̺̺̺̺̓ ̻̺̺̺̓ ̼̺̺̺̓ ̺̺̺̽̓ ̺̺̺̾̓ ̺̺̺̿̓ ̺̺̺̺̔ ̻̺̺̺̔ ̼̺̺̺̔ ̺̺̺̽̔ ̺̺̺̾̔ ̺̺̺̿̔ ̺̺̺̺̕ ̻̺̺̺̕ ̼̺̺̺̕ ̺̺̺̽̕ ̺̺̺̾̕ ̺̺̺̿̕ ̺̺̺̺̖ ̻̺̺̺̖ ̼̺̺̺̖ ̺̺̺̖̽ ̺̺̺̖̾ ̺̺̺̖̿ ̺̺̺̺̗ ̻̺̺̺̗ ̼̺̺̺̗ ̺̺̺̗̽ ̺̺̺̗̾ ̺̺̺̗̿ ̺̺̺̺̘ ̻̺̺̺̘ ̼̺̺̺̘ ̺̺̺̘̽ ̺̺̺̘̾ ̺̺̺̘̿ ̺̺̺̺̙ ̻̺̺̺̙ ̼̺̺̺̙ ̺̺̺̙̽ ̺̺̺̙̾ ̺̺̺̙̿ ̺̺̺̺̚ ̻̺̺̺̚ ̼̺̺̺̚ ̺̺̺̽̚ ̺̺̺̾̚ ̺̺̺̿̚ ̛̺̺̺̺ ̛̻̺̺̺ ̛̼̺̺̺ ̛̺̺̺̽ ̛̺̺̺̾ ̛̺̺̺̿ ̺̺̺̺̜ ̻̺̺̺̜ ̼̺̺̺̜ ̺̺̺̜̽ ̺̺̺̜̾ ̺̺̺̜̿ ̺̺̺̺̝ ̻̺̺̺̝ ̼̺̺̺̝ ̺̺̺̝̽ ̺̺̺̝̾ ̺̺̺̝̿ ̺̺̺̺̞ ̻̺̺̺̞ ̼̺̺̺̞ ̺̺̺̞̽ ̺̺̺̞̾ ̺̺̺̞̿ ̺̺̺̺̟ ̻̺̺̺̟ ̼̺̺̺̟ ̺̺̺̟̽ ̺̺̺̟̾ ̺̺̺̟̿ ̺̺̺̺̠ ̻̺̺̺̠ ̼̺̺̺̠ ̺̺̺̠̽ ̺̺̺̠̾ ̺̺̺̠̿ ̡̺̺̺̺ ̡̻̺̺̺ ̡̼̺̺̺ ̡̺̺̺̽ ̡̺̺̺̾ ̡̺̺̺̿ ̢̺̺̺̺ ̢̻̺̺̺ ̢̼̺̺̺ ̢̺̺̺̽ ̢̺̺̺̾ ̢̺̺̺̿ ̺̺̺̺̣ ̻̺̺̺̣ ̼̺̺̺̣ ̺̺̺̣̽ ̺̺̺̣̾ ̺̺̺̣̿ ̺̺̺̺̤ ̻̺̺̺̤ ̼̺̺̺̤ ̺̺̺̤̽ ̺̺̺̤̾ ̺̺̺̤̿ ̺̺̺̺̥ ̻̺̺̺̥ ̼̺̺̺̥ ̺̺̺̥̽ ̺̺̺̥̾ ̺̺̺̥̿ ̺̺̺̺̦ ̻̺̺̺̦ ̼̺̺̺̦ ̺̺̺̦̽ ̺̺̺̦̾ ̺̺̺̦̿ ̧̺̺̺̺ ̧̻̺̺̺ ̧̼̺̺̺ ̧̺̺̺̽ ̧̺̺̺̾ ̧̺̺̺̿ ̨̺̺̺̺ ̨̻̺̺̺ ̨̼̺̺̺ ̨̺̺̺̽ ̨̺̺̺̾ ̨̺̺̺̿ ̺̺̺̺̩ ̻̺̺̺̩ ̼̺̺̺̩ ̺̺̺̩̽ ̺̺̺̩̾ ̺̺̺̩̿ ̺̺̺̺̪ ̻̺̺̺̪ ̼̺̺̺̪ ̺̺̺̪̽ ̺̺̺̪̾ ̺̺̺̪̿ ̺̺̺̺̫ ̻̺̺̺̫ ̼̺̺̺̫ ̺̺̺̫̽ ̺̺̺̫̾ ̺̺̺̫̿ ̺̺̺̺̬ ̻̺̺̺̬ ̼̺̺̺̬ ̺̺̺̬̽ ̺̺̺̬̾ ̺̺̺̬̿ ̺̺̺̺̭ ̻̺̺̺̭ ̼̺̺̺̭ ̺̺̺̭̽ ̺̺̺̭̾ ̺̺̺̭̿ ̺̺̺̺̮ ̻̺̺̺̮ ̼̺̺̺̮ ̺̺̺̮̽ ̺̺̺̮̾ ̺̺̺̮̿ ̺̺̺̺̯ ̻̺̺̺̯ ̼̺̺̺̯ ̺̺̺̯̽ ̺̺̺̯̾ ̺̺̺̯̿ ̺̺̺̺̰ ̻̺̺̺̰ ̼̺̺̺̰ ̺̺̺̰̽ ̺̺̺̰̾ ̺̺̺̰̿ ̺̺̺̺̱ ̻̺̺̺̱ ̼̺̺̺̱ ̺̺̺̱̽ ̺̺̺̱̾ ̺̺̺̱̿ ̺̺̺̺̲ ̻̺̺̺̲ ̼̺̺̺̲ ̺̺̺̲̽ ̺̺̺̲̾ ̺̺̺̲̿ ̺̺̺̺̳ ̻̺̺̺̳ ̼̺̺̺̳ ̺̺̺̳̽ ̺̺̺̳̾ ̺̺̺̳̿ ̴̺̺̺̺ ̴̻̺̺̺ ̴̼̺̺̺ ̴̺̺̺̽ ̴̺̺̺̾ ̴̺̺̺̿ ̵̺̺̺̺ ̵̻̺̺̺ ̵̼̺̺̺ ̵̺̺̺̽ ̵̺̺̺̾ ̵̺̺̺̿ ̶̺̺̺̺ ̶̻̺̺̺ ̶̼̺̺̺ ̶̺̺̺̽ ̶̺̺̺̾ ̶̺̺̺̿ ̷̺̺̺̺ ̷̻̺̺̺ ̷̼̺̺̺ ̷̺̺̺̽ ̷̺̺̺̾ ̷̺̺̺̿ ̸̺̺̺̺ ̸̻̺̺̺ ̸̼̺̺̺ ̸̺̺̺̽ ̸̺̺̺̾ ̸̺̺̺̿ ̺̺̺̺̹ ̻̺̺̺̹ ̼̺̺̺̹ ̺̺̺̹̽ ̺̺̺̹̾ ̺̺̺̹̿ ̺̺̺̺̺ ̻̺̺̺̺ ̼̺̺̺̺ ̺̺̺̺̽ ̺̺̺̺̾ ̺̺̺̺̿ ̺̺̺̺̻ ̻̺̺̺̻ ̼̺̺̺̻ ̺̺̺̻̽ ̺̺̺̻̾ ̺̺̺̻̿ ̺̺̺̺̼ ̻̺̺̺̼ ̼̺̺̺̼ ̺̺̺̼̽ ̺̺̺̼̾ ̺̺̺̼̿ ̺̺̺̺̽ ̻̺̺̺̽ ̼̺̺̺̽ ̺̺̺̽̽ ̺̺̺̾̽ ̺̺̺̿̽ ̺̺̺̺̾ ̻̺̺̺̾ ̼̺̺̺̾ ̺̺̺̽̾ ̺̺̺̾̾ ̺̺̺̿̾ ̺̺̺̺̿ ̻̺̺̺̿ ̼̺̺̺̿ ̺̺̺̽̿ ̺̺̺̾̿ ̺̺̺̿̿ ̺̺̺̺̺̄ ̻̺̺̺̺̄ ̼̺̺̺̺̄ ̺̺̺̺̽̄ ̺̺̺̺̾̄ ̺̺̺̺̿̄ ̺̺̺̺̺̅ ̻̺̺̺̺̅ ̼̺̺̺̺̅ ̺̺̺̺̽̅ ̺̺̺̾

SPECIMENS OF LINOTYPE FACES

14-POINT
 CONGRESSIONAL
 ITALIC
 PLAIN AND
 CANCELLED
 Two-Letter

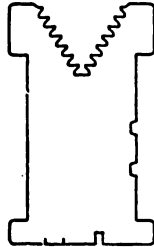

SPECIAL
 CHARACTERS

à á â ã ç é è ê ë ì í î ï ó ô õ ö ù ú û ü
 à á â ã ç é è ê ë ì í î ï ó ô õ ö ù ú û ü

Æ æ Œ œ

~~*Æ æ Œ œ*~~ - - -

- “ ”

- “ ”

MERGENTHALER LINOTYPE CO.

6-POINT NO. 3 WITH BOLD FACE NO. 2

[TWO-LETTER]

Lower case alphabet 14.83 ems

So wenig für mein treues Volk als für Deutsche bedarf es einer Rechenschaft über die Ursachen des Kriegs, welcher jetzt beginnt: Klar liegen sie dem unerblickenden Europa vor Augen. Wir erlagen unter der Uebermacht Frankreichs. Der Friede, der die Hälfte meiner Untertanen mir entriß, gab uns keine Segnungen nicht, denn er schlug uns tiefere Wunden als selbst der Krieg. Das Mark des Landes ward ausgefogen. Die Hauptfestungen blieben vom Feinde besetzt, der Ackerbau ward gelähmt, sowie der sonst so hochgebrachte Kunstfleiß unserer Städte. Die Freiheit des Handels ward gehemmt, und dadurch die Quelle des Erwerbes und des Wohlstandes verstopft. Das Land ward ein Raub der Verarmung. Durch die strengste Erfüllung eingegangener Verbindlichkeiten hoffte ich meinem Volke Erleichterung zu verschaffen, und den französischen Kaiser endlich zu überzeugen, daß es sein eigener Vortheil sei, Preußen seine Unabhängig-

So wenig für mein treues Volk als für Deutsche bedarf es einer Rechenschaft über die Ursachen des Kriegs, welcher jetzt beginnt: Klar liegen sie dem unerblickenden Europa vor Augen. Wir erlagen unter der Uebermacht Frankreichs. Der Friede, der die Hälfte meiner Untertanen mir entriß, gab uns keine Segnungen nicht, denn er schlug uns tiefere Wunden als selbst der Krieg. Das Mark des Landes ward ausgefogen. Die Hauptfestungen blieben vom Feinde besetzt, der Ackerbau ward gelähmt, sowie der sonst so hochgebrachte Kunstfleiß unserer Städte. Die Freiheit des Handels ward gehemmt und dadurch die Quelle des Erwerbes und des Wohlstandes verstopft. Das Land ward ein Raub der Verarmung. Durch die strengste Erfüllung eingegangener Verbindlichkeiten hoffte ich meinem Volke Erleichterung zu verschaffen und den französischen Kaiser endlich zu überzeugen, daß es sein eigener Vortheil sei, Preußen seine Unab-

ABCDEFGHIJKLMNOPQRSTUVWXYZ&
 ABCDEFGHIJKLMNOPQRSTUVWXYZ&

abcdefghijklmnopqrstuvwxyz
 abcdefghijklmnopqrstuvwxyz

1 2 3 4 5 6 7 8 9 0

1 2 3 4 5 6 7 8 9 0

: ; : ! ? () " ' * , - ñ ñ ñ ñ ñ \$ []
 : ; : ! ? () " ' * , - ñ ñ ñ ñ ñ \$ []

ä ö ñ
 ä ö ñ

ñ ñ ñ ñ ñ ñ ñ ñ
 ñ ñ ñ ñ ñ ñ ñ ñ

¼ ½ ¾ ¼ ½ ¾ ¼ ½
 ¼ ½ ¾ ¼ ½ ¾ ¼ ½

Special set table characters. Figures and figure space .052; double figure space .104; comma and period .028. These sizes will be sent unless otherwise ordered.

Alignment. This face aligns with all 6-point German one- and two-letter faces.

Will run in all machines.

To avoid errors read notice on page six

MERGENTHALER LINOTYPE CO.

8-POINT NO. 3 WITH BOLD FACE NO. 2
[TWO-LETTER]

Lower case alphabet 13.01 ems

So wenig für mein treues Volk als für Deutsche bedarf es einer Rechenschaft über die Ursachen des Kriegs, welcher jetzt beginnt: klar liegen sie dem unverblendeten Europa vor Augen. Wir erlagen unter der Uebermacht Frankreichs. Der Friede, der die Hälfte meiner Unterthanen mir entriß, gab uns keine Segnungen nicht, denn er schlug uns tiefere Wunden, als selbst der Krieg. Das Mark des Landes ward ausgefogen. Die Hauptfestungen blieben vom Feinde besetzt, der Ackerbau ward gelähmt, sowie der sonst so hochgebrachte Kunstfleiß unserer Städte. Die Freiheit des Handels ward gehemmt, und dadurch die Quelle des Erwerbes und des Wohlstandes verstopft. Das Land ward ein

So wenig für mein treues Volk als für Deutsche bedarf es einer Rechenschaft über die Ursachen des Kriegs, welcher jetzt beginnt: klar liegen sie dem unverblendeten Europa vor Augen. Wir erlagen unter der Uebermacht Frankreichs. Der Friede, der die Hälfte meiner Unterthanen mir entriß, gab uns keine Segnungen nicht, denn er schlug uns tiefere Wunden als selbst der Krieg. Das Mark des Landes ward ausgefogen. Die Hauptfestungen blieben vom Feinde besetzt, der Ackerbau

ABCDEFGHIJKLMNOPQRSTUVWXYZ&
ABCDEFGHIJKLMNOPQRSTUVWXYZ&

abcdefghijklmnopqrstuvwxyz
abcdefghijklmnopqrstuvwxyz

1 2 3 4 5 6 7 8 9 0
1 2 3 4 5 6 7 8 9 0

, . : ; ! ? () " ' = — fi fl ff lb \$ []
, . : ; ! ? () " ' = — fi fl ff lb \$ []

ä ö ü
ä ö ü

fi it ff ff h ll ch d
fi it ff ff h ll ch d

1/2 1/4 3/8 1/2 5/8 3/4 7/8
1/8 1/4 3/8 1/2 5/8 3/4 7/8

Special set table characters. Figures and figure space .0665; double figure space .133; comma and period .03325. These sizes will be sent unless otherwise ordered.

Alignment. This face allgns with all 8-point German one- and two-letter faces.

Will run in all machines.

To avoid errors read notice on page six

MERGENTHALER LINOTYPE CO.

8-POINT NO. 3 WITH BOLD FACE NO. 2

[TWO-LETTER]

Lower case alphabet 13.01 ems

So wenig für mein treues Volk als für Deutsche bedarf es einer Rechenschaft über die Ursachen des Kriegs, welcher jetzt beginnt: klar liegen sie dem unverblendeten Europa vor Augen. Wir erlagen unter der Uebermacht Frankreichs. Der Friede, der die Hälfte meiner Untertanen mir entriß, gab uns keine Segnungen nicht, denn er schlug uns tiefere Wunden, als selbst der Krieg. Das Mark des Landes ward ausgefogen. Die Hauptfestungen blieben vom Feinde besetzt, der Ackerbau ward gelähmt, sowie der sonst so hochgebrachte Kunstfleiß unserer Städte. Die Freiheit des Handels ward gehemmt, und dadurch die Quelle des Erwerbes und des Wohlstandes verstopft. Das Land ward ein

So wenig für mein treues Volk als für Deutsche bedarf es einer Rechenschaft über die Ursachen des Kriegs, welcher jetzt beginnt: klar liegen sie dem unverblendeten Europa vor Augen. Wir erlagen unter der Uebermacht Frankreichs. Der Friede, der die Hälfte meiner Untertanen mir entriß, gab uns keine Segnungen nicht, denn er schlug uns tiefere Wunden als selbst der Krieg. Das Mark des Landes ward ausgefogen. Die Hauptfestungen blieben vom Feinde besetzt, der Ackerbau

ABCDEFGHIJKLMNOPQRSTUVWXYZ&
 ABCDEFGHIJKLMNOPQRSTUVWXYZ&

abcdefghijklmnopqrstuvwxyz
 abcdefghijklmnopqrstuvwxyz

1 2 3 4 5 6 7 8 9 0
 1 2 3 4 5 6 7 8 9 0

, . : ; ! ? () " ' = — fi ff lb \$ []
 , . : ; ! ? () " ' = — fi ff lb \$ []

ä ö ü
 ä ö ü

fi ff ff ff ff ff ff
 fi ff ff ff ff ff ff

1/8 1/4 3/8 1/2 5/8 3/4 7/8
 1/8 1/4 3/8 1/2 5/8 3/4 7/8

Special set table characters. Figures and figure space .0665; double figure space .133; comma and period .0325. These sizes will be sent unless otherwise ordered.

Alignment. This face aligns with all 8-point German one- and two-letter faces.

Will run in all machines.

To avoid errors read notice on page six

MERGENTHALER LINOTYPE CO.

9-POINT NO. 3 WITH BOLD FACE NO.2
[TWO-LETTER]

Lower case alphabet 12 37 ems

So wenig für mein treues Volk als für Deutsche bedarf es einer Rechenschaft über die Ursachen des Kriegs, welcher jetzt beginnt: klar liegen sie dem unverbblendeten Europa vor Augen. Wir erlagen unter der Uebermacht Frankreichs. Der Friede, der die Hälfte meiner Unterthanen mir entriß, gab uns seine Segnungen nicht, denn er schlug uns tiefere Wunden, als selbst der Krieg. Das Mark des Landes ward ausgefogen. Die Hauptfestungen blieben vom Feinde besetzt, der Ackerbau ward gelähmt, sowie der sonst so hochgebrachte

So wenig für mein treues Volk als für Deutsche bedarf es einer Rechenschaft über die Ursachen des Kriegs, welcher jetzt beginnt: klar liegen sie dem unverbblendeten Europa vor Augen. Wir erlagen unter der Uebermacht Frankreichs. Der Friede, der die Hälfte meiner Unterthanen mir entriß, gab uns seine Segnungen nicht, denn er schlug uns tiefere Wunden als selbst der Krieg. Das Mark des Landes ward

A B C D E F G H I J K L M N O P Q R S T U V W X Y Z &
A B C D E F G H I J K L M N O P Q R S T U V W X Y Z &

abcdefghijklmnopqrstuvwxyz
abcdefghijklmnopqrstuvwxyz

1 2 3 4 5 6 7 8 9 0
1 2 3 4 5 6 7 8 9 0

. : ; ! ? () " * ' = — fi fl ff lb \$ []
. : ; ! ? () " * ' = — fi fl ff lb \$ []

fi fl ff lb \$ []
fi fl ff lb \$ []

ä ö ü
ä ö ü

1/8 1/4 3/8 1/2 5/8 3/4 7/8
1/8 1/4 3/8 1/2 5/8 3/4 7/8

Special ——— Figures and figure space .074; double ——— period, and quotations .037. These sizes ——— can be ordered. ——— comes with all 9-point German one- and two-letter

To avoid errors read notice on page six

MERGENTHALER LINOTYPE CO.

9-POINT NO. 3 WITH BOLD FACE NO.3
[TWO-LETTER]

Lower case alphabet 12.37 ems

So wenig für mein treues Volk als für Deutsche bedarf es einer Rechenschaft über die Ursachen des Kriegs, welcher jetzt beginnt: klar liegen sie dem unverbundenen Europa vor Augen. Wir erlagen unter der Uebermacht Frankreichs. Der Friede, der die Hälfte meiner Unterthanen mir entriß, gab uns seine Segnungen nicht, denn er schlug uns tiefere Wunden, als selbst der Krieg. Das Mark des Landes ward ausgefogen. Die Hauptfestungen blieben vom Feinde besetzt, der Ackerbau ward gelähmt, sowie der sonst so hochgebrachte

So wenig für mein treues Volk als für Deutsche bedarf es einer Rechenschaft über die Ursachen des Kriegs, welcher jetzt beginnt: klar liegen sie dem unverbundenen Europa vor Augen. Wir erlagen unter der Uebermacht Frankreichs. Der Friede, der die Hälfte meiner Unterthanen mir entriß, gab uns seine Segnungen nicht, denn er schlug uns tiefere Wunden als selbst der Krieg. Das Mark des Landes ward

ABCDEFGHIJKLMNOPQRSTUVWXYZ
ABCDEFGHIJKLMNOPQRSTUVWXYZ

abcdefghijklmnopqrstuvwxyz
abcdefghijklmnopqrstuvwxyz

1 2 3 4 5 6 7 8 9 0
1 2 3 4 5 6 7 8 9 0

. . . ; ! ? () " * ' = — fi fl ff lb \$ []
. . . ; ! ? () " * ' = — fi fl ff lb \$ []

fi ft f ff h ll ch d
fi ft f ff h ll ch d

ä ö ü
ä ö ü

1/8 1/4 3/8 1/2 5/8 3/4 7/8
1/8 1/4 3/8 1/2 5/8 3/4 7/8

Special set table characters. Figures and figure space .074; double figure space .148; comma, period, and quotations .037. These sizes will be sent unless otherwise ordered.

Alignment. This face aligns with all 9-point German one- and two-letter faces.

Will run in all machines.

To avoid errors read notice on page six

MERGENTHALER LINOTYPE CO.

9-POINT NO. 3 WITH BOLD FACE NO.2
[TWO-LETTER]

Lower case alphabet 12.37 ems

So wenig für mein treues Volk als für Deutsche bedarf es einer Rechenschaft über die Ursachen des Kriegs, welcher jetzt beginnt: Klar liegen sie dem unverbündeten Europa vor Augen. Wir erlagen unter der Uebermacht Frankreichs. Der Friede, der die Hälfte meiner Unterthanen mir entriß, gab uns seine Segnungen nicht, denn er schlug uns tiefere Wunden, als selbst der Krieg. Das Mark des Landes ward ausgefogen. Die Hauptfestungen blieben vom Feinde besetzt, der Ackerbau ward gelähmt, sowie der sonst so hochgebrachte

So wenig für mein treues Volk als für Deutsche bedarf es einer Rechenschaft über die Ursachen des Kriegs, welcher jetzt beginnt: Klar liegen sie dem unverbündeten Europa vor Augen. Wir erlagen unter der Uebermacht Frankreichs. Der Friede, der die Hälfte meiner Unterthanen mir entriß, gab uns seine Segnungen nicht, denn er schlug uns tiefere Wunden als selbst der Krieg. Das Mark des Landes ward

ABCDEFGHIJKLMNOPQRSTUVWXYZ
ABCDEFGHIJKLMNOPQRSTUVWXYZ

abcdefghijklmnopqrstuvwghj
abcdefghijklmnopqrstuvwghj

1 2 3 4 5 6 7 8 9 0
1 2 3 4 5 6 7 8 9 0

, . : ; ! ? () " ' * ' = — fi fl ff th \$ []
, . : ; ! ? () " ' * ' = — fi fl ff th \$ []

fi ft ff ff k ll ch d
fi ft ff ff k ll ch d

ä ö ü
ä ö ü

1/8 1/4 3/8 1/2 5/8 3/4 7/8
1/8 1/4 3/8 1/2 5/8 3/4 7/8

Special set table characters. Figures and figure space .074; double figure space .148; comma, period, and quotations .037. These sizes will be sent unless otherwise ordered.

Alignment. This face aligns with all 9-point German one- and two-letter faces.

Will run in all machines.

To avoid errors read notice on page six

MERGENTHALER LINOTYPE CO.

9-POINT NO. 3 WITH BOLD FACE NO.3
[TWO-LETTER]

Lower case alphabet 12.37 ems

So wenig für mein treues Volk als für Deutsche bedarf es einer Rechenschaft über die Ursachen des Kriegs, welcher jetzt beginnt: Klar liegen sie dem unerblicketen Europa vor Augen. Wir erlagen unter der Uebermacht Frankreichs. Der Friede, der die Hälfte meiner Untertanen mir entriß, gab uns seine Segnungen nicht, denn er schlug uns tiefere Wunden, als selbst der Krieg. Das Mark des Landes ward ausgefogen. Die Hauptfestungen blieben vom Feinde besetzt, der Ackerbau ward gelähmt, sowie der sonst so hochgebrachte

So wenig für mein treues Volk als für Deutsche bedarf es einer Rechenschaft über die Ursachen des Kriegs, welcher jetzt beginnt: Klar liegen sie dem unerblicketen Europa vor Augen. Wir erlagen unter der Uebermacht Frankreichs. Der Friede, der die Hälfte meiner Untertanen mir entriß, gab uns seine Segnungen nicht, denn er schlug uns tiefere Wunden als selbst der Krieg. Das Mark des Landes ward

ABCDEFGHIJKLMNOPQRSTUVWXYZ&
ABCDEFGHIJKLMNOPQRSTUVWXYZ&

abcdefghijklmnopqrstuvwxyz

abcdefghijklmnopqrstuvwxyz

1 2 3 4 5 6 7 8 9 0

1 2 3 4 5 6 7 8 9 0

, . : ; ! ? () " ' = — fi ff ff lb \$ []
, . : ; ! ? () " ' = — fi ff ff lb \$ []

fi ft b ff h ll ch d

fi ft h ff h ll ch d

ä ö ü

ä ö ü

1/8 1/4 3/8 1/2 5/8 3/4 7/8

1/8 1/4 3/8 1/2 5/8 3/4 7/8

Special set table characters. Figures and figure space .074; double figure space .148; comma, period, and quotations .037. These sizes will be sent unless otherwise ordered.

Alignment. This face aligns with all 9-point German one- and two-letter faces.

Will run in all machines.

To avoid errors read notice on page six

MERGENTHALER LINOTYPE CO.

9-POINT NO. 3 WITH BOLD FACE NO.3
[TWO-LETTER]

Lower case alphabet 12.37 ems

So wenig für mein treues Volk als für Deutsche bedarf es einer Rechenschaft über die Ursachen des Kriegs, welcher jetzt beginnt: Klar liegen sie dem unerblicketen Europa vor Augen. Wir erlagen unter der Uebermacht Frankreichs. Der Friede, der die Hälfte meiner Untertanen mir entriß, gab uns seine Segnungen nicht, denn er schlug uns tiefere Wunden, als selbst der Krieg. Das Mark des Landes ward ausgefogen. Die Hauptfestungen blieben vom Feinde besetzt, der Ackerbau ward gelähmt, sowie der sonst so hochgebrachte

So wenig für mein treues Volk als für Deutsche bedarf es einer Rechenschaft über die Ursachen des Kriegs, welcher jetzt beginnt: Klar liegen sie dem unerblicketen Europa vor Augen. Wir erlagen unter der Uebermacht Frankreichs. Der Friede, der die Hälfte meiner Untertanen mir entriß, gab uns seine Segnungen nicht, denn er schlug uns tiefere Wunden als selbst der Krieg. Das Mark des Landes ward

ABCDEFGHIJKLMNOPQRSTUVWXYZ&
ABCDEFGHIJKLMNOPQRSTUVWXYZ&

abcdefghijklmnopqrstuvwxyz

abcdefghijklmnopqrstuvwxyz

1 2 3 4 5 6 7 8 9 0

1 2 3 4 5 6 7 8 9 0

, . : ; ! ? () " ' = — fi fl ff lb \$ []
, . : ; ! ? () " ' = — fi fl ff lb \$ []

fi ft b ff h ll ch d
fi ft h ff h ll ch d

ä ö ü
ä ö ü

1/8	1/4	3/8	1/2	5/8	3/4	7/8
1/8	1/4	3/8	1/2	5/8	3/4	7/8

Special set table characters. Figures and figure space .074; double figure space .148; comma, period, and quotations .037. These sizes will be sent unless otherwise ordered.

Alignment. This face aligns with all 9-point German one- and two-letter faces.

Will run in all machines.

To avoid errors read notice on page six

MERGENTHALER LINOTYPE CO.

10-POINT NO. 3 WITH BOLD FACE NO. 2
[TWO-LETTER]

Lower case alphabet 11.75 ems

So wenig für mein treues Volk als für Deutsche bedarf es einer Rechenschaft über die Ursachen des Krieges, welcher jetzt beginnt: klar liegen sie dem unverbündeten Europa vor Augen. Wir erlagen unter der Uebermacht Frankreichs. Der Friede, der die Hälfte meiner Unterthanen mir entriß, gab uns seine Segnungen nicht, denn er schlug uns tiefere Wunden, als selbst der Krieg. Das Mark des Landes ward ausgefogen. Die Hauptfestungen blieben

So wenig für mein treues Volk als für Deutsche bedarf es einer Rechenschaft über die Ursachen des Krieges, welcher jetzt beginnt: klar liegen sie dem unverbündeten Europa vor Augen. Wir erlagen unter der Uebermacht Frankreichs. Der Friede, der die Hälfte meiner Unterthanen mir entriß, gab uns seine Segnungen nicht, denn er schlug uns tiefere Wun-

ABCDEFGHIJKLMNOPQRSTUVWXYZ&
ABCDEFGHIJKLMNOPQRSTUVWXYZ&

abcdefghijklmnopqrstuvwxyz
abcdefghijklmnopqrstuvwxyz

1 2 3 4 5 6 7 8 9 0
1 2 3 4 5 6 7 8 9 0

. . . ; ! ? () " ' * ' - — fi ff ff fb \$ []
. . . ; ! ? () " ' * ' - — fi ff ff fb \$ []

fi ft ff ff ff ff ff ff
fi ft ff ff ff ff ff ff

ä ö ü
ä ö ü

1/8 1/4 3/8 1/2 5/8 3/4 7/8
1/8 1/4 3/8 1/2 5/8 3/4 7/8

Special set table characters. Figures and figure space .074; double figure space .148; comma and period .037. These sizes will be sent unless otherwise ordered.

Alignment. This face aligns with all 10-point German one- and two-letter faces.

Will run in all machines.

To avoid errors read notice on page six

MERGENTHALER LINOTYPE CO.

11-POINT NO. 3 WITH BOLD FACE NO. 2
[TWO-LETTER]

Lower case alphabet 11.19 ems

So wenig für mein treues Volk als für Deutsche bedarf es einer Rechenschaft über die Ursachen des Kriegs, welcher jetzt beginnt: klar liegen sie dem unverblendeten Europa vor Augen. Wir erlagen unter der Uebermacht Frankreichs. Der Friede, der die Hälfte meiner Unterthanen mir entriß, gab uns keine Segnungen nicht, denn er schlug uns tiefere Wunden, als selbst der Krieg. Das

So wenig für mein treues Volk als für Deutsche bedarf es einer Rechenschaft über die Ursachen des Kriegs, welcher jetzt beginnt: klar liegen sie dem unverblendeten Europa vor Augen. Wir erlagen unter der Uebermacht Frankreichs. Der Friede, der die Hälfte meiner Unterthanen mir

ABCDEFGHIJKLMNOPQRSTUVWXYZ
ABCDEFGHIJKLMNOPQRSTUVWXYZ

abcdefghijklmnopqrstuvwxyz
abcdefghijklmnopqrstuvwxyz

1 2 3 4 5 6 7 8 9 0
1 2 3 4 5 6 7 8 9 0

, . : ; ! ? () " ' - — fi fl ff lb \$ []
, . : ; ! ? () " ' - — fi fl ff lb \$ []

ä ö ü fi ff ff ff U ch ç
ä ö ü fi ff ff ff U ch ç

1/8 1/4 3/8 1/2 5/8 3/4 7/8
1/8 1/4 3/8 1/2 5/8 3/4 7/8

Special set table characters. Figures and figure space .0815; double figure space .163; comma, and period .04075. These sizes will be sent unless otherwise ordered.

Alignment. This face aligns with all 11-point German one- and two-letter faces.

Will run in all machines.

To avoid errors read notice on page six

MERGENTHALER LINOTYPE CO.

10-POINT RUSSIAN OLD STYLE WITH ANTIQUE NO. 1
[TWO-LETTER]

Lower case alphabet 20.55 ems

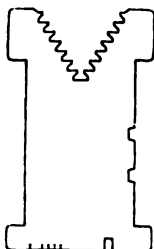

Первая заповѣдь состояла въ томъ, что человѣкъ не только не долженъ убивать, но не долженъ гнѣваться на брата, не долженъ никого считать ничтожнымъ, „рака“, а если поссорится съ кѣмъ-либо, долженъ мириться прежде, чѣмъ приносить даръ Богу, т. е. молиться.

Вторая заповѣдь состояла въ томъ, что человѣкъ не только не долженъ прелюбодѣйствовать, но долженъ избѣгать наслажденія красотою женщины, долженъ, разъ, сойдясь съ одной женщиной, никогда не измѣнять ей.

Третья заповѣдь состояла въ томъ, что человѣкъ не долженъ обѣщаться въ чемъ-нибудь съ клятвою.

Четвертая заповѣдь состояла въ томъ, что человѣкъ не только не долженъ воздавать око за око, но долженъ подставлять другую щеку, когда ударять по одной, долженъ прощать обиды и съ смиреніемъ нести ихъ и никому не отказывать въ томъ, чего хотятъ отъ него люди.

Пятая заповѣдь состояла въ томъ, что человѣкъ не только не долженъ ненавидѣть враговъ, не воевать съ ними, но долженъ любить ихъ, помогать, служить имъ.

АВВГДЕЖЗІЙКЛМНОПРСТУФХЦЧШЩЪЫЬ
ЪЭЮЯӨВ

АВВГДЕЖЗІЙКЛМНОПРСТУФХЦЧШЩЪЫЬ
ЪЭЮЯӨВ

абвгдежзійклмнопрстуфхцчшщъыьѣэюяөв

абвгдежзійклмнопрстуфхцчшщъыьѣэюяөв

, . : ; ? ! () ' ' * - — . . . 1 2 3 4 5 6 7 8 9 0

, . : ; ? ! () ' ' * - — . . . 1 2 3 4 5 6 7 8 9 0

To avoid errors read notice on page six

SPECIMENS OF LINOTYPE FACES

10-POINT SERBIAN OLD STYLE WITH ANTIQUE NO. 1 [TWO-LETTER]

Lower case alphabet 18.93 ems

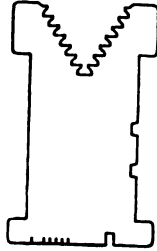

ТРЕЋИ ПЕРИОД. Страдање српског народа. (Од 1367—1804. год.) Други период српске историје јест период славе српског народа; напротив трећи је период пун догађаја, који ожалашћавају, јер су јасни знаци тога, како је српски народ у својој снази слабо и падао, како је најпосле грехом својих старешина, дошао до пропасти.

Одломци из песама Јелене Поповићеве: Кад би могла у зорицу белу, Да посетим горицу зелену, Да накидам бршљана и лишћа, Те би села украј поточића, Па би онда зелен венац вила, И овако тијо беседила: Како ли се зелен венац вио, И по бистрој водици пловио, Тако и Ти да би роде мио, Стару славу српску задобио. Док би тако тихо беседила, Суза би се у поточић слила, Не би л' суза до Босне пловила, Тужној земљи путе отворила, Сретне путе и слободе миле, Да избави те патнике живе.

А где је? А где је сада радост и нада? Ружица бела, што је увела? И уста мала, што су ме звала: Рођена мајко! Беше ми слатко. Мајкина мила, руке савила, На веки спава, Милица мала. — Панчево, 1873.

**АБВГДЂЕЖЗИЈКЛЉМНЊОПРСТЋУФХЦЧШШ
АБВГДЂЕЖЗИЈКЛЉМНЊОПРСТЋУФХЦЧШШ**

абвгдђежзијкљмнњопрстћуфхцчшш

абвгдђежзијкљмнњопрстћуфхцчшш

, . : ; ? ! () ' ' * - — . . . 1 2 3 4 5 6 7 8 9 0
, . : ; ? ! () ' ' * - — . . . 1 2 3 4 5 6 7 8 9 0

To avoid errors read notice on page six



***One-Letter
Job Faces***

MERGENTHALER LINOTYPE CO.

6-POINT CLARENDON NO. 1

[ONE-LETTER]

Lower case alphabet 16.36 ems

The most ancient materials used for recording events were bricks, tiles, shells, and tables of stone. The modes of writing on these different substances were various. The tiles and brick were impressed with a stamp when in a soft state; the shells and tablets of stone were etched or graven, the figures or characters being cut in their surface, and in some cases also stained with various colors. It was by the ancient art of stamping that the walls, palaces, and towers of Babylon were covered with hieroglyphics, which have but recently been brought to light from under the immense mounds of Mesopotamia by Layard and other explorers. The patriarch Job, who is supposed to have lived 2,300 years after the creation, exclaimed, "O that my words were now written! O that they were printed in a book! that they were graven with an iron pen, and hid in the rock forever!" Stung with the unjust accusation of his friends, he desires to record his words that the generations following might see the justice of his cause. The English translation has given the allusion to printing to the text, the original word signifying rather to engrave

The most ancient materials employed for recording events were bricks, tiles, shells, and tables of stone. The modes of writing on these different substances were various. The tiles and brick were impressed with a stamp when in a soft state; the shells and tablets of stone were etched or graven, the figures or characters being cut in their surface, and in some cases also stained with various colors. It was by the ancient art of stamping that the walls, palaces, and towers of Babylon were covered with hieroglyphics, which have but recently been brought to light from under the immense mounds of Mesopotamia by Layard and other explorers. The patriarch Job, who is supposed to have lived about 2,300 years after the creation, exclaimed, "O that my words were now written! O that they were printed in a book! that they were graven with an iron pen, and hid in the rock for-

ABCDEFGHIJKLMNOPQRSTUVWXYZ&

abcdefghijklmnopqrstuvwxyz

1 2 3 4 5 6 7 8 9 0

, . : ; ! ? () ' ' * - . . . n n n n n n n @ £ \$ []

ı ı ı ı ı ı ı

Special set table characters. Figures and figure space .050; double figure space .100; comma, period, and quotations .031. These sizes will be sent unless otherwise ordered.

Alignment. This face aligns with all 6-point one- and two-letter faces except German.

Will run in all machines.

To avoid errors read notice on page six

MERGENTHALER LINOTYPE CO.

8-POINT CLARENDON NO. 1

[ONE-LETTER]

Lower case alphabet 14.16 ems

The most ancient materials used for recording events were bricks, tiles, shells, and tables of stone. The modes of writing on these different substances were various. The tiles and brick were impressed with a stamp when in a soft state; the shells and tablets of stone were etched or graven, the figures or characters being cut in their surface, and in some cases also stained with various colors. It was by the ancient art of stamping that the walls, palaces, and towers of Babylon were covered with hieroglyphics, which have but recently been brought to light from under the immense mounds of Mesopotamia by Layard and other explorers. The patriarch Job, who is supposed to have lived 2,300 years after the creation, exclaimed, "O that my words were now written! O that they were printed in a book! that

The most ancient materials employed for recording events were bricks, tiles, shells and tables of stone. The modes of writing on these different substances were various. The tiles and brick were impressed with a stamp when in a soft state; the shells and tablets of stone were etched or graven, the figures or characters being cut in their surface, and in some cases also stained with various colors. It was by the ancient art of stamping that the walls, palaces, and towers of Babylon were covered with hieroglyphics, which have but recently been brought to light from under the

ABCDEFGHIJKLMNOPQRSTUVWXYZ&

abcdefghijklmnopqrstuvwxyz

1 2 3 4 5 6 7 8 9 0

. . : ; ! ? (|) * ' ' — . . . ã ñ ñ ñ ñ ñ ñ ñ @ £ \$ ½ []

Special set table characters. Figures and figure space .059; double figure space .118; comma, period, and quotations .0295. These sizes will be sent unless otherwise ordered.

Alignment. This face aligns with all 8-point one- and two-letter faces having high alignment except German.

Will run in all machines.

To avoid errors read notice on page six

MERGENTHALER LINOTYPE CO.

10-POINT CLARENDON NO. 1 [ONE-LETTER]

Lower case alphabet 12.56 ems

The most ancient materials used for recording events were bricks, tiles, shells, and tables of stone. The modes of writing on these different substances were various. The tiles and brick were impressed with a stamp when in a soft state; the shells and tablets of stone were etched or graven, the figures or characters being cut in their surface, and in some cases also stained with various colors. It was by the ancient art of stamping that the walls, palaces, and towers of Babylon were covered with hieroglyphics, which have

The most ancient materials employed for recording events were bricks, tiles, shells, and tables of stone. The modes of writing on these different substances were various. The tiles and brick were impressed with a stamp when in a soft state the tablets of stone and shells were etched or graven, the figures or characters being cut in their surface, and in some cases also stained with various colors. It was by the ancient art of stamping that the walls, palaces,

ABCDEFGHIJKLMNOPQRSTUVWXYZ&

abcdefghijklmnopqrstuvwxy

1 2 3 4 5 6 7 8 9 0

, . : ; ! ? (|) * ' ' - . . . fi ff fl fl ll @ £ \$ []

1/8 1/4 3/8 1/2 5/8 3/4 7/8

True set table characters. Figures and en quad .070; em quad .140; comma, period, and quotations .035. These sizes will be sent unless otherwise ordered.

Alignment. This face aligns with all 10-point one- and two-letter faces except German.

Will run in all machines.

To avoid errors read notice on page six

MERGENTHALER LINOTYPE CO.

12-POINT CLARENDON NO. 1
[ONE-LETTER]

Lower case alphabet 12.58 ems

The most ancient materials employed for recording events were bricks, tiles, shells, and tables of stone. The modes of writing on these different substances were various. The tiles and brick were impressed with a stamp when in a soft state; the shells and tablets of stone were etched or graven, the figures or characters being cut in their surface, and in some cases also stained with various colors. It was by the

The most ancient materials employed for recording events were bricks, tiles, shells, and tables of stone. The modes of writing on these different substances were various. The tiles and brick were impressed with a stamp when in a soft state; the shells and tablets of stone were etched or graven,

ABCDEFGHIJKLMNOPQRSTUVWXYZ&

abcdefghijklmnopqrstuvwxyz

1 2 3 4 5 6 7 8 9 0

, . : ; ! ? (|) * ' " - _ . . . fi ff fl fl fl fl lb @ £ \$ []

$\frac{1}{8}$ $\frac{1}{4}$ $\frac{3}{8}$ $\frac{1}{2}$ $\frac{5}{8}$ $\frac{3}{4}$ $\frac{7}{8}$

True set table characters. Figures and en quad .084; em quad .168; comma, period, and quotations .042. These sizes will be sent unless otherwise ordered.

Alignment. This face aligns with all 12-point one- and two-letter faces except German.

Will run in all machines.

To avoid errors read notice on page six

MERGENTHALER LINOTYPE CO.

8-POINT IONIC NO. 1
[ONE-LETTER]

Lower case alphabet 15.41 ems

The most ancient materials used for recording events were bricks, tiles, shells, and tables of stone. The modes of writing on these different substances were various. The tiles and brick were impressed with a stamp when in a soft state; the shells and tablets of stone were etched or graven, the figures or characters being cut in their surface, and in some cases also stained with various colors. It was by the ancient art of stamping that the walls, palaces, and towers of Babylon were covered with hieroglyphics, which have but recently been brought to light from under the immense mounds of Mesopotamia by Layard and other explorers. The patriarch Job, who is supposed to have lived 2,300 years after the creation, exclaimed, "O that my words were now written! O that

The most ancient materials employed for recording events were bricks, tiles, shells, and tables of stone. The modes of writing on these different substances were various. The tiles and brick were impressed with a stamp when in a soft state; the shells and tablets of stone were etched or graven, the figures or characters being cut in their surface, and in some cases also stained with various colors. It was by the ancient art of stamping that the walls, palaces, and towers of Babylon were covered with hieroglyphics, which have but recently been brought to light from under

ABCDEFGHIJKLMN OPQRSTUVWXYZ &
abcdefghijklmnopqrstuvwxyz

1 2 3 4 5 6 7 8 9 0

, . : ; ! P (|) * ' - — . . . fi ff ff ff ff lb @ \$ []

1/8 1/4 3/8 1/2 5/8 3/4 7/8

Special set table characters. Figures and figure space .070; double figure space .140; comma, period, and quotations .035. These sizes will be sent unless otherwise ordered.

Alignment. This face aligns with all 8-point one- and two-letter faces having high alignment except German.

Will run in all machines.

To avoid errors read notice on page six

MERGENTHALER LINOTYPE CO.

10-POINT IONIC NO. 1
[ONE-LETTER]

Lower case alphabet 15.54 ems

The most ancient materials used for recording events were bricks, tiles, shells, and tables of stone. The modes of writing on these different substances were various. The tiles and brick were impressed with a stamp when in a soft state; the shells and tablets of stone were etched or graven, the figures or characters being cut in their surface, and in some cases also stained with various colors. It was by the ancient art of stamping that the walls, palaces, and towers of Babylon were covered with hier-

The most ancient materials used for recording events were bricks, tiles, shells, and tables of stone. The modes of writing on these different substances were various. The tiles and brick were impressed with a stamp when in a soft state; the shells and tablets of stone were etched or graven, the figures or characters being cut in their surface,

ABCDEFGHIJKLMNOPQRSTUVWXYZ&

abcdefghijklmnopqrstuvwxy

1 2 3 4 5 6 7 8 9 0

, . : ; ! P (|) * ' ' - . . . fi ff m n th @ £ \$ []

1/8 1/4 3/8 1/2 5/8 3/4 7/8

Special set table characters. Figures and figure space .091; comma, period, and quotations .0455. These sizes will be sent unless otherwise ordered.

Alignment. This face aligns with all 10-point one- and two-letter faces except German.

Will run in all machines.

To avoid errors read notice on page six

MERGENTHALER LINOTYPE CO.

8-POINT TITLE NO. 1

[ONE-LETTER]

Lower case alphabet 13.70 ems

The most ancient materials used for recording events were bricks, tiles, shells, and tables of stone. The modes of writing on these different substances were various. The tiles and brick were impressed with a stamp when in a soft state; the shells and tablets of stone were etched or graven, the figures or characters being cut in their surface, and sometimes stained with various colors. It was by the ancient art of stamping that the walls, palaces, and towers of Babylon were covered with hieroglyphics, which have but recently been brought to light from under the immense mounds of Mesopotamia by Layard and other explorers. The patriarch Job who is supposed to have lived about 2,300 years after the creation, exclaimed, "O that

The most ancient materials employed for recording events were bricks, tiles, shells, and tables of stone. The modes of writing on these different substances were various. The tiles and brick were impressed with a stamp when in a soft state; the shells and tablets of stone were etched or graven, the figures or characters being cut in their surface, and in some cases also stained with various colors. It was by the ancient art of stamping that the walls, palaces, and towers of Babylon were covered with hieroglyphics, which have but recently been brought to light from under the immense mounds of Mesopotamia by Lay-

ABCDEFGHIJKLMNPOQRSTUVWXYZ&

abcdefghijklmnpqrstuvwxy z

1 2 3 4 5 6 7 8 9 0

, . : ; ! ? (|) * ' ' - - . . . fi fi ff ffi ffi lb @ £ []

1/8 1/4 3/8 1/2 5/8 3/4 7/8

True set table characters. Figures and en quad .056; em quad .112; comma, period, and quotations .028. These sizes will be sent unless otherwise ordered.

Substitute table characters for use with this face can be had as follows: 8-point Title No. 1 Modernized figures.—Figures and en quad .056; em quad .112.

Alignment. This face aligns with all 8-point one- and two-letter faces having low alignment except German.

Will run in all machines.

To avoid errors read notice on page six

MERGENTHALER LINOTYPE CO.

10-POINT TITLE NO. 1

[ONE-LETTER]

Lower case alphabet 13.18 ems

The most ancient materials used for recording events were bricks, tiles, shells, and tables of stone. The modes of writing on these different substances were various. The tiles and brick were impressed with a stamp when in a soft state; the shells and tablets of stone were etched or graven, the figures or characters being cut in their surface, and in some cases also stained with various colors. It was by the ancient art of stamping that the walls, palaces, and towers of

The most ancient materials used for recording events were bricks, tiles, shells, and tables of stone. The modes of writing on these different substances were various. The tiles and brick were impressed with a stamp when in a soft state; the shells and tablets of stone were etched or graven, the figures or chracters being cut in their surface, and in some cases also stained with various colors. It was by the ancient art of stamping that

ABCDEFGHIJKLMN OPQRSTUVWXYZ&

abcdefghijklmnopqrstuvwxyz

1 2 3 4 5 6 7 8 9 0

, . : ; ! ? (|) * ' ' - — . . . fi fl ff ffi ffl lb @ £ \$ []

1/8 1/4 3/8 1/2 5/8 3/4 7/8

True set table characters. Figures and en quad .070; em quad .140; comma, period, and quotations .035. These sizes will be sent unless otherwise ordered.

Substitute table characters for use with this face can be had as follows: 10-point Title No. 1 Modernized figures.—Figures and en quad .070; em quad .140.

Alignment. This face aligns with all 10-point one- and two-letter faces except German.

Will run in all machines.

To avoid errors read notice on page six

MERGENTHALER LINOTYPE CO.

6-POINT TITLE NO. 2

[ONE-LETTER]

Lower case alphabet 16.64 ems

The most ancient materials used for recording events were bricks, tiles, shells, and tables of stone. The modes of writing on these different substances were various. The tiles and brick were impressed with a stamp when in a soft state; the shells and tablets of stone were etched or graven, the figures or characters being cut in their surface, and in some cases also stained with various colors. It was by the ancient art of stamping that the walls, palaces, and towers of Babylon were covered with hieroglyphics, which have but recently been brought to light from under the immense mounds of Mesopotamia by Layard and other explorers. The patriarch Job, who is supposed to have lived 2,300 years after the creation, exclaimed, "O that my words were now written! O that they were printed in a book! that they were graven with an iron pen, and hid in the rock forever." Stung with the unjust accusation of his friends, he desires to record his words that the generation following

The most ancient materials employed for recording events were bricks, tiles, shells, and tables of stone. The modes of writing on these different substances were various. The tiles and brick were impressed with a stamp when in a soft state; the shells and tablets of stone were etched or graven, the figures or characters being cut in their surface, and in some cases also stained with various colors. It was by the ancient art of stamping that the walls, palaces, and towers of Babylon were covered with hieroglyphics, which have but recently been brought to light from under the immense mounds of Mesopotamia by Layard and other explorers. The patriarch Job, who is supposed to have lived about 2,300 years after the creation, exclaimed, "O that my words were now written! O that they were printed in a book! that they were graven with an iron pen and hid in the rock forever." Stung by the unjust accusation of his friends he wishes to record his words that the gen-

ABCDEFGHIJKLMNOPQRSTUVWXYZ&

abcdefghijklmnopqrstuvwxyz

1 2 3 4 5 6 7 8 9 0

. . . ; ! ? (|) * ' ' - — . . . ñ ñ ñ ñ ñ ñ @ £ \$ []
1/8 1/4 3/8 1/2 5/8 3/4 7/8

Special set table characters. Figures and figure space .056; double figure space .112; comma, period, and quotations .028. These sizes will be sent unless otherwise ordered.

Alignment. This face aligns with all 6-point one- and two-letter faces except German.

Will run in all machines.

To avoid errors read notice on page six

MERGENTHALER LINOTYPE CO.

7-POINT TITLE NO. 2
[ONE-LETTER]

Lower case alphabet 15.45 ems

The most ancient materials employed for recording events were bricks, tiles, shells, and tables of stone. The modes of writing on these different substances were various. The tiles and brick were impressed with a stamp when in a soft state; the shells and tablets of stone were etched or graven, the figures or characters being cut in their surface, and in some cases also stained with various colors. It was by the ancient art of stamping that the walls, palaces, and towers of Babylon were covered with hieroglyphics, which have but recently been brought to light from under the immense mounds of Mesopotamia by Layard and other explorers. The patriarch Job, who is supposed to have lived about 2,300 years after the creation, exclaimed, "O that my words were now written! O that they were printed in a book! that they were graven with an iron pen and hid in

The most ancient materials used for recording events were bricks, tiles, shells, and tables of stone. The modes of writing on these different substances were various. The tiles and brick were impressed with a stamp when in a soft state; the shells and tablets of stone were etched or graven, the figures or characters being cut in their surface, and in some cases also stained with various colors. It was by the ancient art of stamping that the walls, palaces, and towers of Babylon were covered with hieroglyphics, which have but recently been brought to light from under the immense mounds of Mesopotamia by Layard and other explorers. The patriarch Job, who is supposed to have lived about 2,300 years after the creation, ex-

ABCDEFGHIJKLMNOPQRSTUVWXYZ&
abcdefghijklmnopqrstuvwxyz

1 2 3 4 5 6 7 8 9 0

. . . ; ! ? (|) * ' ' - . . . fi ff ffi ffl lb @ £ \$ []

¼ ½ ¾ ⅓ ⅔

Special set table characters. Figures and figure space .0553; double figure space .1107; comma, period, and quotations 0277. Unit system, ¼-point basis. These sizes will be sent unless otherwise ordered.

Substitute table characters for use with this face can be had as follows: 7-point Title No. 2 Modernized figures.—Figures and figure space .0553; double figure space .1107.

Alignment. This face aligns with all 7-point one- and two-letter faces and all 8-point faces having high alignment.

Will run in all machines.

To avoid errors read notice on page six

MERGENTHALER LINOTYPE CO.

8-POINT TITLE NO. 2
[ONE-LETTER]

Lower case alphabet 15.08 ems

The most ancient materials used for recording events were bricks, tiles, shells, and tables of stone. The modes of writing on these different substances were various. The tiles and brick were impressed with a stamp when in a soft state; the shells and tablets of stone were etched or graven, the figures or characters being cut in their surface, and in some cases also stained with various colors. It was by the ancient art of stamping that the walls, palaces, and towers of Babylon were covered with hieroglyphics, which have but recently been brought to light from under the immense mounds of Mesopotamia by Layard and other explorers. The patriarch Job, who is supposed

The most ancient materials employed for recording events were tables of stone, bricks, tiles, and shells. The modes of writing on these different substances were various. The tiles and brick were impressed with a stamp when in a soft state; the shells and tablets of stone were etched or graven, the figures or characters being cut in their surface, and in some cases also stained with various colors. It was by the ancient art of stamping that the walls, palaces, and towers of Babylon were covered with hieroglyphics, which have but recently been brought to light from under

ABCDEFGHIJKLMNOPQRSTUVWXYZ&

abcdefghijklmnopqrstuvwxy

1 2 3 4 5 6 7 8 9 0

. . . ; ! ? (|) * ' ' - — . . . fi fl ff ffi fll th @ £ \$ []

1/8 1/4 3/8 1/2 5/8 3/4 7/8

Special set table characters. Figures and figure space .070; double figure space .140; comma, period, and quotations .035. These sizes will be sent unless otherwise ordered.

Substitute table characters for use with this face can be had as follows: 8-point Title No. 2 Modernized figures.—Figures and figure space .070; double figure space .140.

Alignment. This face aligns with all 8-point one- and two-letter faces having low alignment except German.

Will run in all machines.

To avoid errors read notice on page six

MERGENTHALER LINOTYPE CO.

10-POINT TITLE NO. 2 [ONE-LETTER]

Lower case alphabet 13.90 ems

The most ancient materials used for recording events were bricks, tiles, shells, and tables of stone. The modes of writing on these different substances were various. The tiles and brick were impressed with a stamp when in a soft state; the shells and tablets of stone were etched or graven, the figures or characters being cut in their surface, and in some cases also stained with various colors. It was by the ancient art of stamping that the walls, palaces, and towers of Babylon were cov-

The most ancient materials employed for recording events were bricks, tiles, shells, and tables of stone. The modes of writing on these different substances were various. The tiles and brick were impressed with a stamp when in a soft state; the shells and tables of stone were etched or graven, the figures or characters being cut in their surface, and in some cases also stained with various

ABCDEFGHIJKLMN OPQRSTUVWXYZ&
abcdefghijklmnopqrstuvwxyz

1 2 3 4 5 6 7 8 9 0

, . : ; ! ? (|) * ' ' - . . . fi ff ffi ffl lb @ £ \$ []

1/8 1/4 3/8 1/2 5/8 3/4 7/8

True set table characters. Figures and en quad .070; em quad .140; comma, period, and quotations .035. These sizes will be sent unless otherwise ordered.

Substitute table characters for use with this face can be had as follows: 10-point Title No. 2 Modernized figures.—Figures and en quad .070; em quad .140.

Alignment. This face aligns with all 10-point one- and two-letter faces except German.

Will run in all machines.

To avoid errors read notice on page six

MERGENTHALER LINOTYPE CO.

12-POINT TITLE NO. 2
[ONE-LETTER]

Lower case alphabet 12.58 ems

The most ancient materials employed for recording events were bricks, tiles, shells, and tables of stone. The modes of writing on these different substances were various. The tiles and brick were impressed with a stamp when in a soft state; the shells and tablets of stone were etched or graven, the figures or characters being cut in their surface, and in some cases also stained with

The most ancient materials used for recording events were bricks, tiles, shells, and tables of stone. The modes of writing on these different substances varied. The tiles and brick were impressed with a stamp when in a soft state; the shells and tablets of stone were etched or gra-

ABCDEFGHIJKLMNOPQRSTUVWXYZ&
abcdefghijklmnopqrstuvwxyz

1 2 3 4 5 6 7 8 9 0

, . : ; ! ? (|) * ' ' - . . . fi fl ff ffi ffl fb @ £ \$ []

1/8 1/4 3/8 1/2 5/8 3/4 7/8

True set table characters Figures and en quad .083; em quad .166; comma, period, and quotations .0415. Unit system, 1/2-point basis. These sizes will be sent unless otherwise ordered.

Alignment. This face aligns with all 12-point one- and two-letter faces except German.

Will run in machines Nos. 2, 3, 4 and 5.

To avoid errors read notice on page six

MERGENTHALER LINOTYPE CO.

12-POINT DE VINNE OUTLINE
[ONE-LETTER]

Lower case alphabet 14.96 ems

The most ancient materials employed for recording events were bricks, tiles, shells, and tables of stone. The modes of writing on these different substances were various. The tiles and brick were impressed with a stamp when in a soft state; the shells and tablets of stone were etched or graven, the figures or characters being cut in their surface,

The most ancient materials employed in recording events were bricks, tiles, shells, and tables of stone. The modes of writing on these different substances were various. The tiles and brick were impressed with a stamp when in a soft state; the

ABCDEFGHIJKLMNOPQRSTUVWXYZ&

abcdefghijklmnopqrstuvwxyz

1 2 3 4 5 6 7 8 9 0

, . : ; ! ? (|) * ' " = . . . fi fl ff ffi ffl lb @ £ \$ []

1/8 1/4 3/8 1/2 5/8 3/4 7/8

Special set table characters. Figures and figure space .0968; double figure space .1936; comma, period, and quotations .0484. Type founders' point system. These sizes will be sent unless otherwise ordered.

Alignment. This face aligns with all 12-point one- and two-letter faces except German.

Will run in machines Nos. 2, 3, 4 and 5.

To avoid errors read notice on page six

MERGENTHALER LINOTYPE CO.



8-POINT DE VINNE CONDENSED [ONE-LETTER]

Lower case alphabet 12.23 ems

The most ancient materials employed for the recording events were bricks, tiles, shells, and tables of stone. The modes of writing on these different substances were various. The tiles and brick were impressed with a stamp when in a soft state; the shells and tablets of stone were etched or graven, the figures or characters being cut in their surface, and in some cases also stained with various colors. It was by the ancient art of stamping that the walls, palaces, and towers of Babylon were covered with hieroglyphics, which have but recently been brought to light from under the immense mounds of Mesopotamia by Layard and other explorers. The patriarch Job, who is supposed to have lived about 2,300 years after the creation, exclaimed, "O that my words were now written! O that they were printed in a book; that they were graven with an iron pen, and hid in the rock forever!" Stung with the unjust accusation of his friends

The most ancient materials that were used for recording events were bricks, tiles, shells, and tables of stone. The modes of writing on these different substances were various. The tiles and brick were impressed with a stamp when in a soft state; the shells and tablets of stone were etched or graven, the figures or characters being cut in their surface, and in some cases also stained with various colors. It was by the ancient art of stamping that the walls, palaces, and towers of Babylon were covered with hieroglyphics, which have but recently been brought to light from under the immense mounds of Mesopotamia by Layard and other explorers. The

ABCDEFGHIJKLMN OPQRSTUVWXYZ&

abcdefghijklmnopqrstuvwxyz

1 2 3 4 5 6 7 8 9 0

, . : ; ! ? (|) * ' ' - . . . ñ ñ ñ ñ ñ ñ ñ @ £ \$ []

1/8 1/4 3/8 1/2 5/8 3/4 7/8

True set table characters. Figures and en quad .0553; em quad .1107; comma, period, and quotations .0277. Type founders' point system. These sizes will be sent unless otherwise ordered.

Alignment. This face aligns with all 8-point one- and two-letter faces having low alignment except German.

Will run in all machines.

To avoid errors read notice on page six

MERGENTHALER LINOTYPE CO.

10-POINT DE VINNE CONDENSED
[ONE-LETTER]

Lower case alphabet 11.02 ems

The most ancient materials employed for recording events were bricks, tiles, shells, and tables of stone. The modes of writing on these different substances were various. The tiles and brick were impressed with a stamp when in a soft state; the shells and tables of stone were etched or graven, the figures or characters being cut in their surface, and in some cases also stained with various colors. It was by the ancient art of stamping that the walls, palaces, and towers of Babylon were covered with hieroglyphics, which have but recently been brought to light from under the great mounds of Mesopotamia by Layard and other explorers. The patriarch Job, who is supposed to have lived about 2,300 years

The most ancient materials employed for recording events were bricks, tiles, shells, and tables of stone. The modes of writing on these different substances were various. The tiles and brick were impressed with a stamp when in a soft state; the shells and tablets of stone were etched or graven, the figures or characters being cut in their surface, and in some cases also stained with various colors. It was by the ancient art of stamping that the walls, palaces,

ABCDEFGHIJKLMNPOQRSTUVWXYZ&

abcdefghijklmnpqrstuvwxy

1 2 3 4 5 6 7 8 9 0

, . : ; ? ! (|) * ' ' - — . . . fi fl ff ffi ffl lb @ £ \$ []

1/8 1/4 3/8 1/2 5/8 3/4 7/8

True set table characters. Figures and en quad .0691; em quad .1383; comma, period and quotations .0346. These sizes will be sent unless otherwise ordered.

Alignment. This face aligns with all 10-point one- and two-letter faces except German.

Will run in all machines.

To avoid errors read notice on page six

MERGENTHALER LINOTYPE CO.



12-POINT DE VINNE CONDENSED
[ONE-LETTER]

Lower case alphabet 11.68 ems

The most ancient materials employed for recording events were bricks, tiles, shells, and tables of stone. The modes of writing on these different substances were various. The tiles and brick were impressed with a stamp when in a soft state; the shells and tablets of stone were etched or graven, the figures or characters being cut in their surface, and in some cases also stained with various colors. It was by the ancient art of

The most ancient materials employed in recording events were bricks, tiles, shells, and tables of stone. The modes of writing on these different substances were various. The tiles and brick were impressed with a stamp when in a soft state; the shells and tablets of stone were etched or graven, the figures or

ABCDEFGHIJKLMN OPQRSTUVWXYZ&

abcdefghijklmnpqrstuvwxy z

1 2 3 4 5 6 7 8 9 0

, . : ; ! ? (|) * ' " - _ . . . fi fl ff ffi ffl fb @ £ \$ []

1/8 1/4 3/8 1/2 5/8 3/4 7/8

True set table characters. Figures and en quad .083; em quad .166; comma, period, and quotations .0415. Type foundry's point system. These sizes will be sent unless otherwise ordered.

Alignment. This face aligns with all 12-point one- and two-letter faces except German.

Will run in machines Nos. 2, 3, 4 and 5.

To avoid errors read notice on page six

MERGENTHALER LINOTYPE CO.



12-POINT DE VINNE CONDENSED
[ONE-LETTER]

Lower case alphabet 11.68 ems

The most ancient materials employed for recording events were bricks, tiles, shells, and tables of stone. The modes of writing on these different substances were various. The tiles and brick were impressed with a stamp when in a soft state; the shells and tablets of stone were etched or graven, the figures or characters being cut in their surface, and in some cases also stained with various colors. It was by the ancient art of

The most ancient materials employed in recording events were bricks, tiles, shells, and tables of stone. The modes of writing on these different substances were various. The tiles and brick were impressed with a stamp when in a soft state; the shells and tablets of stone were etched or graven, the figures or

ABCDEFGHIJKLMN OPQRSTUVWXYZ&

abcdefghijklmnopqrstuvwxyz

1 2 3 4 5 6 7 8 9 0

, . : ; ! ? (|) * ' " - . . . fi ff fl fl fi fb @ £ \$ []

1/8 1/4 3/8 1/2 5/8 3/4 7/8

True set table characters. Figures and en quad .083; em quad .166; comma, period, and quotations .0415. Type foundry's point system. These sizes will be sent unless otherwise ordered.

Alignment. This face aligns with all 12-point one- and two-letter faces except German.

Will run in machines Nos. 2, 3, 4 and 5.

To avoid errors read notice on page six

MERGENTHALER LINOTYPE CO.

6-POINT JENSON

[ONE-LETTER]

Lower case alphabet 14.61 ems

The most ancient materials employed for recording events were bricks, tiles, shells, and tables of stone. The modes of writing on these different substances were various. The tiles and brick were impressed with a stamp when in a soft state; the shells and tablets of stone were etched or graven, the figures or characters being cut in their surface, and in some cases also stained with various colors. It was by the ancient art of stamping that the walls, palaces, and towers of Babylon were covered with hieroglyphics, which have but recently been brought to light from under the immense mounds of Mesopotamia by Layard and other explorers. The patriarch Job, who is supposed to have lived about 2,300 years after the creation, exclaimed, "O that my words were now written! O that they were printed in a book! that they were graven with an iron pen, and hid in the rock forever!" Stung with the unjust accusations of his friends, he desires to record his words that the generations following might see the justice of his cause. The English translation has given the allusion to printing to the text, the original word signifying rather to engrave on a plate, which was doubtless the only printing known to Job. Montfaucon purchased at Rome in 1699 an ancient book entirely composed of

The most ancient materials employed for recording events were bricks, tiles, shells, and tables of stone. The modes of writing on these different substances were various. The tiles and brick were impressed with a stamp when in a soft state; the shells and tablets of stone were etched or graven, the figures or characters being cut in their surface, and in some cases also stained with various colors. It was by the ancient art of stamping that the walls of Babylon were covered with hieroglyphics, which have but recently been brought to light from under the immense mounds of Mesopotamia by Layard and other explorers. The patriarch Job, who is said to have lived about 2,300 years after the creation, exclaimed, "O that my words were now written! O that they were printed in a book! that they were graven with an iron pen, and hid in the rock forever!" Stung with the unjust accusations of his friends, he desires to record his words so that the coming generations might see the justice of his cause. The English version has given the allusion to printing to the text, the original word

ABCDEFGHIJKLMNOPQRSTUVWXYZ&

abcdefghijklmnopqrstuvwxyz

1 2 3 4 5 6 7 8 9 0

. : ; ! ? (|) * ' ' - . . . ß ß ß ß ß ß @ £ \$ []

¼ ½ ¾ ¼ ¾

Special set table characters. Figures and figure space .0553; double figure space .1107; comma, period, and quotations .0277. These sizes will be sent unless otherwise ordered.

Alignment. This face aligns with all 6-point one- and two-letter faces except German.

Will run in all machines.

To avoid errors read notice on page six

MERGENTHALER LINOTYPE CO.

8-POINT JENSON

[ONE-LETTER]

Lower case alphabet 12.36 ems

The most ancient materials employed for recording events were bricks, tiles, shells, and tables of stone. The modes of writing on these different substances were various. The tiles and brick were impressed with a stamp when they were in a soft state; the shells and tablets of stone were etched or graven, the figures or characters being cut in their surface, and in some cases also stained with various colors. It was by the ancient art of stamping that the walls, palaces, and the towers of Babylon were covered with hieroglyphics, which have but recently been brought to light from under the immense mounds of Mesopotamia by Layard and other explorers. The patriarch Job, who is supposed to have lived about 2,300 years after the creation, exclaimed, "O that my words were now written! O that they were printed in a book! that they were graven with an iron pen, and hid in the rock forever!"

The most ancient materials employed for recording events were bricks, tiles, shells, and tables of stone. The modes of writing on these different substances were various. The tiles and brick were impressed with a stamp when in a soft state; the shells and tablets of stone were etched or graven, the figures or characters being cut in their surface, and in some cases also stained in various colors. It was by the ancient art of stamping that the walls, palaces, and towers of Babylon were entirely covered with hieroglyphics, which have recently been brought to light from under the immense mounds of Mesopotamia by Layard

ABCDEFGHIJKLMN OPQRSTUVWXYZ&

abcdefghijklmnopqrstuvwxyz

1 2 3 4 5 6 7 8 9 0

, . : ; ! ? (|) * ' ' - — . . . fi ff ffi ffl fb @ £ \$ []

1/8 1/4 3/8 1/2 5/8 3/4 7/8

True set table characters. Figures and en quad .0553; em quad .1107; comma, period, and quotations .0277. Type founders' point system. These sizes will be sent unless otherwise ordered.

Alignment. This face aligns with all 8-point one- and two-letter faces having low alignment except German.

Will run in all machines.

To avoid errors read notice on page six

MERGENTHALER LINOTYPE CO.

10-POINT JENSON
[ONE-LETTER]

Lower case alphabet 18.24 ems

The most ancient materials employed for recording events were bricks, tiles, shells, and tables of stone. The modes of writing on these different substances were various. The tiles and brick were impressed with a stamp when in a soft state; the shells and tablets of stone were etched or graven, the figures or characters being cut in their surface, and in some cases also stained with various colors. It was by the ancient art of stamping that the walls, palaces, and towers of Babylon were covered with hieroglyphics, which have but recently been brought to light from

The most ancient materials used for recording events were bricks, tiles, shells, and tables of stone. The modes of writing on these different substances were various. The tiles and brick were impressed with a stamp when in a soft state; the shells and tablets of stone were etched or graven, the figures or characters being cut in their surface, and in some cases also stained with various colors. It was by the

ABCDEFGHIJKLMNOPQRSTUVWXYZ&

abcdefghijklmnopqrstuvwxyz

1 2 3 4 5 6 7 8 9 0

, . : ; ? ! (|) * ' ' - _ . . . fi fl ff ffi ffl fb @ £ \$ []

1/8 1/4 3/8 1/2 5/8 3/4 7/8

True set table characters. Figures and en quad .0691; em quad .1383; comma, period, and quotations .0346. Type founders' point system. These sizes will be sent unless otherwise ordered.

Alignment. This face aligns with all 10-point one- and two-letter faces except German.

Will run in all machines.

To avoid errors read notice on page six

MERGENTHALER LINOTYPE CO.

12-POINT JENSON
[ONE-LETTER]

Lower case alphabet 12.42 ems

The most ancient materials used for recording events were bricks, tiles, shells, and tables of stone. The modes of writing on these different substances were various. The tiles and brick were impressed with a stamp when in a soft state; the shells and tablets of stone were etched or graven, the figures or characters being cut in their surface, and in some cases also stained with various colors. It was by the ancient art

The most ancient materials used for recording events were bricks, tiles, shells, and tables of stone. The modes of writing on these different substances were various. The tiles and brick were impressed with a stamp when in a soft state; the shells and tablets of stone were etched or graven, the fig-

ABCDEFGHIJKLMNOPQRSTUVWXYZ&

abcdefghijklmnopqrstuvwxyz

1 2 3 4 5 6 7 8 9 0

, . : ; ! ? (|) * ' ' - — . . . fi fl ff ffi ffl fb @ £ \$ []

$\frac{1}{8}$ $\frac{1}{4}$ $\frac{3}{8}$ $\frac{1}{2}$ $\frac{5}{8}$ $\frac{3}{4}$ $\frac{7}{8}$

True set table characters. Figures and en quad .083; em quad .166; comma, period, and quotations .0415. Type foundry's point system. These sizes will be sent unless otherwise ordered.

Alignment. This face aligns with all 12-point one- and two-letter faces except German.

Will run in machines Nos. 2, 3, 4 and 5.

MERGENTHALER LINOTYPE CO.

6-POINT ALDINE NO. 1

[ONE-LETTER]

Lower case alphabet 14.89 ems

The most ancient materials employed for recording events were bricks, tiles, shells, and tables of stone. The modes of writing on these different substances were various. The tiles and brick were impressed with a stamp when in a soft state; the shells and tablets of stone were etched or graven, the figures or characters being cut in their surface, and in some cases also stained with various colors. It was by the ancient art of stamping that the walls and palaces of Babylon were covered with hieroglyphics, which have but recently been brought to light from under the immense mounds of Mesopotamia by Layard and other explorers. The patriarch Job, who is supposed to have lived about 2,300 years after the creation, exclaimed, "O that my words were now written! O that they were printed in a book! that they were graven with an iron pen, and hid in the rock forever!" Stung with the unjust accusation of his friends, he desires to record his words that the generations following might see the justice of his cause. The English translation has given the allusion to printing to the text, the original word signifying rather to engrave on a plate, which was doubtless the only printing known to Job. Montfaucon purchased at Rome in 1699

The most ancient materials used for recording events were bricks, tiles, shells, and tables of stone. The modes of writing on these different substances were various. The tiles and brick were impressed with a stamp when in a soft state; the shells and tablets of stone were etched or graven, the figures or characters being cut in their surface, and in some cases also stained with various colors. It was by their art of stamping that the walls and palaces of Babylon were covered with hieroglyphics, which have but recently been brought to light from under the immense mounds of Mesopotamia by Layard and other explorers. The patriarch Job, who is supposed to have lived 2,300 years after the creation, exclaimed, "O that my words were now written! O that they were printed in a book! that they were graven with an iron pen, and hid in the rock forever!" Stung with the unjust accusation of his friends, he desires to record his words so that the coming generations might see the justice of his cause. The English translation has given

ABCDEFGHIJKLMNPOQRSTUVWXYZ&

abcdefghijklmnopqrstuvwxyz

1 2 3 4 5 6 7 8 9 0

, . : ; ! ! (|) * ' ' - . . . # # # # # # # @ £ \$ []

¼ ½ ¾

Special set table characters. Figures and figure space .0553; double figure space .1107; comma, period, and quotations .0277. Unit system, ¼-point basis. These sizes will be sent unless otherwise ordered.

Alignment. This face aligns with all 6-point one- and two-letter faces except German.

Will run in all machines.

To avoid errors read notice on page six

MERGENTHALER LINOTYPE CO.

8-POINT ALDINE NO. 1

[ONE-LETTER]

Lower case alphabet 15.21 ems

The most ancient materials employed for recording events were bricks, tiles, shells, and tables of stone. The modes of writing on these different substances were various. The tiles and brick were impressed with a stamp when in a soft state; the shells and tablets of stone were etched or graven, the figures or characters being cut in their surface, and in some cases also stained with various colors. It was by the ancient art of stamping that the walls and palaces of Babylon were covered with hieroglyphics, which have but recently been brought to light from under the immense mounds of Mesopotamia by Layard and other explorers. The patriarch Job, who is said to have lived 2,800 years after the creation, exclaimed, "O that my words were now written! O that they were printed in a book! that they were graven with an iron pen, and hid in

The most ancient materials used for recording events were bricks, tiles, shells, and tables of stone. The modes of writing on these different substances were various. The tiles and brick were impressed with a stamp when in a soft state; while the shells and tablets of stone were etched or graven, the figures or characters being cut in their surface, and in some cases also stained with various colors. It was by the ancient art of stamping that the walls, palaces, and even the towers of Babylon were covered with hieroglyphics, which have but recent-

ABCDEFGHIJKLMNOPQRSTUVWXYZ&

abcdefghijklmnopqrstuvwxyz

1 2 3 4 5 6 7 8 9 0

, . : ; ! ? (|) * ' ' — . . . ñ ñ ñ ñ ñ ñ ñ @ £ \$ []

½ ¼ ⅓ ½ ⅔ ¾ ⅞

Special set table characters. Figures and figure space .0691; double figure space .1383; comma, period, and quotations .0345. Unit system, ¼-point basis. These sizes will be sent unless otherwise ordered.

Alignment. This face aligns with all 8-point one- and two-letter faces having low alignment except German.

Will run in all machines.

To avoid errors read notice on page six

MERGENTHALER LINOTYPE CO.

10-POINT ALDINE NO. 1
[ONE-LETTER]

Lower case alphabet 14.84 ems

The most ancient materials used for recording events were bricks, tiles, shells, and tables of stone. The modes of writing on these different substances were various. The tiles and brick were impressed with a stamp when in a soft state; the shells and tablets of stone were graven or etched, the figures or characters being cut in their surface, and in some cases also stained with various colors. It was by the art of stamping that the walls, palaces, and towers of Babylon were covered with hieroglyphics,

The most ancient materials used in recording events were bricks, tiles, shells, and tablets of stone. The modes of writing on these different substances were various. The tiles and brick were impressed with a stamp when in a soft state; the shells and tablets of stone were etched or graven, the figures or characters being cut in their surface, and in some cases also stained with various colors. It was by the

ABCDEFGHIJKLMN OPQRSTUVWXYZ&

abcdefghijklmnopqrstu vwx yz

1 2 3 4 5 6 7 8 9 0

, . : ; ! ? (|) ' ' * - — . . . fl fl ff fl fl lb @ £ \$

[] 1/8 1/4 3/8 1/2 5/8 3/4 7/8

Special set table characters. Figures and figure space .0761; double figure space .1521; comma, period, and quotations .038. Unit system, 1/4-point basis. These sizes will be sent unless otherwise ordered.

Alignment. This face aligns with all 10-point one- and two-letter faces except German.

Will run in all machines.

To avoid errors read notice on page six

MERGENTHALER LINOTYPE CO.

10-POINT ALDINE NO. 1
[ONE-LETTER]

Lower case alphabet 14.84 ems

The most ancient materials used for recording events were bricks, tiles, shells, and tables of stone. The modes of writing on these different substances were various. The tiles and brick were impressed with a stamp when in a soft state; the shells and tablets of stone were graven or etched, the figures or characters being cut in their surface, and in some cases also stained with various colors. It was by the art of stamping that the walls, palaces, and towers of Babylon were covered with hieroglyphics,

The most ancient materials used in recording events were bricks, tiles, shells, and tablets of stone. The modes of writing on these different substances were various. The tiles and brick were impressed with a stamp when in a soft state; the shells and tablets of stone were etched or graven, the figures or characters being cut in their surface, and in some cases also stained with various colors. It was by the

ABCDEFGHIJKLMN OPQRSTUVWXYZ&

abcdefghijklmnopqrstuvwxy z

1 2 3 4 5 6 7 8 9 0

, . : ; ! ? (|) ' ' * - — . . . fl ff ff ff ff lb @ £ \$

[] 1/8 1/4 3/8 1/2 5/8 3/4 7/8

Special set table characters. Figures and figure space .0761; double figure space .1521; comma, period, and quotations .038. Unit system, 1/4-point basis. These sizes will be sent unless otherwise ordered.

Alignment. This face aligns with all 10-point one- and two-letter faces except German.

Will run in all machines.

To avoid errors read notice on page six

MERGENTHALER LINOTYPE CO.

10-POINT CONDENSED TITLE NO. 1
[ONE-LETTER]

Lower case alphabet 14.45 ems

The most ancient materials used for recording events were bricks, tiles, shells, and tables of stone. The modes of writing on these different substances were various. The tiles and brick were impressed with a stamp when in a soft state; the shells and tablets of stone were etched or graven, the figures or characters being cut in their surface, and in some cases also stained with various colors. It was by the ancient art

The most ancient materials employed for recording events were bricks, tiles, shells, and tables of stone. The modes of writing on these different substances were various. The tiles and brick were impressed with a stamp when in a soft state; the shells and tablets of stone were etched or graven, the figures or characters being cut in their surface, and in some cases also stained with various col-

ABCDEFGHIJKLMN OPQRSTUVWXYZ&

abcdefghijklmnopqrstuvwxyz

1 2 3 4 5 6 7 8 9 0

, . : ; ! ? (|) * ' ' - . . . fi fl ff ffi ffl lb @ £ \$ []

1/8 1/4 3/8 1/2 5/8 3/4 7/8

Special set table characters. Figures and figure space .091; comma, period, and quotations .0455. These sizes will be sent unless otherwise ordered.

Alignment. This face aligns with all 10-point one- and two-letter faces except German.

Will run in all machines.

To avoid errors read notice on page six

MERGENTHALER LINOTYPE CO.

12-POINT CONDENSED TITLE NO. 1
[ONE-LETTER]

Lower case alphabet 13.35 ems

The most ancient materials employed for recording events were bricks, tiles, shells, and tables of stone. The modes of writing on these different substances were various. The tiles and brick were impressed with a stamp when in a soft state; the shells and tablets of stone were etched or graven, the figures or characters being cut in their surface,

The most ancient materials used for recording events were bricks, tiles, shells, and tables of stone. The modes of writing on these different substances were varied. The tiles and brick were impressed with a stamp when in a soft state; the shells and tablets of stone were etched or graven, the figures or char-

ABCDEFGHIJKLMNOPQRSTUVWXYZ&
abcdefghijklmnopqrstuvwxyz
1 2 3 4 5 6 7 8 9 0
, . : ; ! ? (|) * ' ' - — . . . fi fl ff ffi ffl lb @ £ \$ []
1/8 1/4 3/8 1/2 5/8 3/4 7/8

True set table characters. Figures and en quad .084; em quad .168; comma, period, and quotations .042. These sizes will be sent unless otherwise ordered.

Alignment. This face aligns with all 12-point one- and two-letter faces except German.

Will run in all machines.

To avoid errors read notice on page six

MERGENTHALER LINOTYPE CO.

12-POINT CONDENSED TITLE NO. 1
[ONE-LETTER]

Lower case alphabet 13.35 ems

The most ancient materials employed for recording events were bricks, tiles, shells, and tables of stone. The modes of writing on these different substances were various. The tiles and brick were impressed with a stamp when in a soft state; the shells and tablets of stone were etched or graven, the figures or characters being cut in their surface,

The most ancient materials used for recording events were bricks, tiles, shells, and tables of stone. The modes of writing on these different substances were varied. The tiles and brick were impressed with a stamp when in a soft state; the shells and tablets of stone were etched or graven, the figures or char-

ABCDEFGHIJKLMNOPQRSTUVWXYZ&

abcdefghijklmnopqrstuvwxyz

1 2 3 4 5 6 7 8 9 0

, . : ; ! ? (|) * ' - — ... fi fl ff ffi ffl lb @ £ \$ []

1/8 1/4 3/8 1/2 5/8 3/4 7/8

True set table characters. Figures and en quad .084; em quad .168; comma, period, and quotations .042. These sizes will be sent unless otherwise ordered.

Alignment. This face aligns with all 12-point one- and two-letter faces except German.

Will run in all machines.

To avoid errors read notice on page six

MERGENTHALER LINOTYPE CO.

10-POINT CONDENSED TITLE NO. 2
[ONE-LETTER]

Lower case alphabet 12.66 ems

The most ancient materials employed for recording events were bricks, tiles, shells, and tables of stone. The modes of writing on these different substances were various. The tiles and brick were impressed with a stamp when in a soft state; the shells and tablets of stone were etched or graven, the figures or characters being cut in their surface, and in some cases also stained with various colors. It was by the ancient art of stamping that the walls, palaces, and towers of Babylon were covered with hieroglyphics,

The most ancient materials used for recording events were bricks, tiles, shells, and tables of stone. The modes of writing on these different substances were various. The tiles and brick were impressed with a stamp when in a soft state; the shells and tablets of stone were etched or graven, the figures or characters being cut in their surface, and in some cases also stained with various colors. It was by the ancient art of stamping that the

ABCDEFGHIJKLMNOPQRSTUVWXYZ&

abcdefghijklmnopqrstuvwxyz

1 2 3 4 5 6 7 8 9 0

, . : ; ! ? (|) * ' - _ . . . ¢ ¢ ¢ ¢ ¢ ¢ ¢ @ £ \$ []

1/8 1/4 3/8 1/2 5/8 3/4 7/8

True set table characters. Figures and en quad .0691; em quad .1382; comma, period, and quotations .0345. These sizes will be sent unless otherwise ordered.

Alignment. This face aligns with all 10-point one- and two-letter faces except German.
Will run in all machines.

To avoid errors read notice on page six

MERGENTHALER LINOTYPE CO.

12-POINT CONDENSED TITLE NO. 2

[ONE-LETTER]

Lower case alphabet 11.97 ems

The most ancient materials used for recording events were bricks, tiles, shells, and tables of stone. The modes of writing on these different substances were various. The tiles and brick were impressed with a stamp when in a soft state; the shells and tablets of stone were etched or graven, the figures or characters being cut in their surface, and in some cases also stained with various colors. It was by the ancient art

The most ancient materials employed for recording events were bricks, tiles, shells, and tables of stone. The modes of writing on these different substances were various. The tiles and brick were impressed with a stamp when in a soft state; the shells and tablets of stone were etched or graven, the fig-

ABCDEFGHIJKLMN OPQRSTUVWXYZ&

abcdefghijklmnopqrstuvwxy z

1 2 3 4 5 6 7 8 9 0

, . : ; ! ? (|) * ' ' - — . . . fi fi fi fi fi lb @ £ \$ []

1/8 1/4 3/8 1/2 5/8 3/4 7/8

True set table characters. Figures and en quad .084; em quad .168; comma, period and quotations .042. These sizes will be sent unless otherwise ordered.

Alignment. This face aligns with all 12-point one- and two-letter faces except German.

Will run in all machines.

To avoid errors read notice on page six

SPECIMENS OF LINOTYPE FACES

**12-POINT
CONDENSED
TITLE NO. 2
One-Letter**

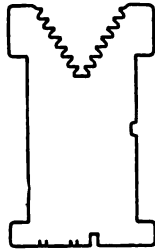

**SPECIAL
CHARACTERS**

Æ Œ æ œ

§ ¶ || † ‡ - / ¢

1/3 2/3 1/5 2/5 3/5 4/5 1/6 5/6 1/8 1/4 3/8 1/2 5/8 3/4 7/8 1/3 2/3 1/5 2/5 3/5 4/5 5/6

- - - - -

+ + - × × ÷ =

Superior: 1 2 3 4 5 6 7 8 9 0

☼ ☽ ☾ ☿ ♁ ♂ ♃ ♅ ♇ ♉ ♋ ♍ ♏ ♐ ♑ ♒ ♓ ♔ ♕ ♖ ♗ ♘ ♙ ♚ ♛ ♜ ♝ ♞ ♟ ♠ ♡ ♢ ♣ ♤ ♥ ♦ ♧ ♨ ♩ ♪ ♫ ♬ ♭ ♮ ♯ ♰ ♱ ♲ ♳ ♴ ♵ ♶ ♷ ♸ ♹ ♺ ♻ ♼ ♽ ♾ ♿
Ⓢ Ⓣ Ⓤ Ⓥ Ⓦ Ⓧ Ⓨ Ⓩ ⓐ ⓑ ⓓ ⓔ ⓖ ⓗ ⓙ ⓚ ⓛ ⓜ ⓞ ⓟ ⓠ ⓡ ⓢ ⓣ ⓤ ⓥ ⓦ ⓧ ⓨ ⓩ ⓪ ⓫ ⓬ ⓭ ⓮ ⓯ ⓰ ⓱ ⓲ ⓳ ⓴ ⓵ ⓶ ⓷ ⓸ ⓹ ⓺ ⓻ ⓼ ⓽ ⓾ ⓿
Ⓚ Ⓛ Ⓜ Ⓨ Ⓩ ⓐ ⓑ ⓓ ⓔ ⓖ ⓗ ⓙ ⓚ ⓛ ⓜ ⓞ ⓟ ⓠ ⓡ ⓢ ⓣ ⓤ ⓥ ⓦ ⓧ ⓨ ⓩ ⓪ ⓫ ⓬ ⓭ ⓮ ⓯ ⓰ ⓱ ⓲ ⓳ ⓴ ⓵ ⓶ ⓷ ⓸ ⓹ ⓺ ⓻ ⓼ ⓽ ⓾ ⓿
Ⓚ Ⓛ Ⓜ Ⓨ Ⓩ ⓐ ⓑ ⓓ ⓔ ⓖ ⓗ ⓙ ⓚ ⓛ ⓜ ⓞ ⓟ ⓠ ⓡ ⓢ ⓣ ⓤ ⓥ ⓦ ⓧ ⓨ ⓩ ⓪ ⓫ ⓬ ⓭ ⓮ ⓯ ⓰ ⓱ ⓲ ⓳ ⓴ ⓵ ⓶ ⓷ ⓸ ⓹ ⓺ ⓻ ⓼ ⓽ ⓾ ⓿
Ⓚ Ⓛ Ⓜ Ⓨ Ⓩ ⓐ ⓑ ⓓ ⓔ ⓖ ⓗ ⓙ ⓚ ⓛ ⓜ ⓞ ⓟ ⓠ ⓡ ⓢ ⓣ ⓤ ⓥ ⓦ ⓧ ⓨ ⓩ ⓪ ⓫ ⓬ ⓭ ⓮ ⓯ ⓰ ⓱ ⓲ ⓳ ⓴ ⓵ ⓶ ⓷ ⓸ ⓹ ⓺ ⓻ ⓼ ⓽ ⓾ ⓿

MERGENTHALER LINOTYPE CO.

11-POINT GOTHIC NO. 1
[ONE-LETTER]

Lower case alphabet 12.14 ems

The most ancient materials employed for recording events were bricks, tiles, shells, and tables of stone. The modes of writing on these different substances were various. The tiles and brick were impressed with a stamp when in a soft state; the shells and tablets of stone were etched or graven, the figures or characters being cut in their surface, and in some cases also stained with various colors.

The most ancient materials employed for recording events were bricks, tiles, shells, and tables of stone. The modes of writing on these different substances were various. The tiles and brick were impressed with a stamp when in a soft state; the shells and tablets of stone were etched or graven, the figures or characters being cut in their surface, and in some cases also stained with

ABCDEFGHIJKLMNOPQRSTUVWXYZ&

abcdefghijklmnopqrstuvwxyz

1 2 3 4 5 6 7 8 9 0

, . : ; ! ? (|) * ' - _ . . . fi fl ff ffi ffi fb @ £ \$ []

1/8 1/4 3/8 1/2 5/8 3/4 7/8

Special set table characters. Figures and figure space .084. This size will be sent unless otherwise ordered.

Alignment. This face aligns with all 11-point one- and two-letter faces having low alignment, except German.

Will run in all machines.

To avoid errors read notice on page six

MERGENTHALER LINOTYPE CO.

12-POINT GOTHIC NO. 1
[ONE-LETTER]

Lower case alphabet 12.23 ems

The most ancient materials used for recording events were bricks, tiles, shells, and tables of stone. The modes of writing on these different substances were various. The tiles and brick were impressed with a stamp when in a soft state; the shells and tablets of stone were etched or graven, the figures or characters being cut in their surface, and in some cases

The most ancient materials used for recording events were bricks, tiles, shells, and tables of stone. The modes of writing on these different substances were various. The tiles and brick were impressed with a stamp when in a soft state; the shells and tablets of stone were etched or graven, the figures or char-

ABCDEFGHIJKLMN OPQRSTUVWXYZ&

abcdefghijklmnopqrstuvwxyz

1 2 3 4 5 6 7 8 9 0

, . : ; ! ? () * ' - — _ _ _ fi fl ff ffi ffl tb @ £ \$ []

$\frac{1}{8}$ $\frac{1}{4}$ $\frac{3}{8}$ $\frac{1}{2}$ $\frac{5}{8}$ $\frac{3}{4}$ $\frac{7}{8}$

Special set table characters. Figures and figure space .091; double figure space .182; comma, period, and quotations .0455. These sizes will be sent unless otherwise ordered.

Alignment. This face aligns with all 12-point one- and two-letter faces having low alignment except German.

To avoid errors read notice on page six

MERGENTHALER LINOTYPE CO.

7-POINT GOTHIC NO. 2 [ONE-LETTER]

Lower case alphabet 15.24 ems

The most ancient materials used for recording events were bricks, tiles, shells, and tables of stone. The modes of writing on these different substances were various. The tiles and brick were impressed with a stamp when in a soft state; the shells and tablets of stone were etched or graven, the figures or characters being cut in their surface, and in some cases also stained with various colors. It was by the ancient art of stamping that the walls, palaces, and towers of Babylon were covered with hieroglyphics, which have but recently been brought to light from under the immense mounds of Mesopotamia by Layard and other explorers. The patriarch Job, who is supposed to have lived 2,300 years after the creation, exclaimed, "O that my words were now written! O that they were printed in a book! that they were graven with an iron pen, and hid in the rock for-

The most ancient materials employed for recording events were bricks, tiles, shells, and tables of stone. The ways of writing on these different substances were various. The tiles and brick were impressed with a stamp when in a soft state; the shells and tablets of stone were etched or graven, the figures or characters being cut in their surface, and in some cases also stained with various colors. It was by the ancient art of stamping that the walls, palaces, and towers of Babylon were covered with hieroglyphics, which have but recently been brought to light from under the great mounds of Mesopotamia by Layard and other explorers. The patriarch Job, who is supposed to have lived 2,300 years after the creation,

ABCDEFGHIJKLMNOPQRSTUVWXYZ&

abcdefghijklmnopqrstuvwxyz

1 2 3 4 5 6 7 8 9 0

, . : ; ! ? (|) * ' ' — _ _ _ fi fl ff ffi ffl fb @ £ \$ []

1/8 1/4 3/8 1/2 5/8 3/4 7/8

Special set table characters. Figures and figure space .063; double figure space .126; comma, period, and quotations .0315. These sizes will be sent unless otherwise ordered.

Alignment. This face aligns with all 7-point one- and two-letter faces except German.

Will run in all machines.

To avoid errors read notice on page six

MERGENTHALER LINOTYPE CO.

8-POINT GOTHIC CONDENSED NO. 2 [ONE-LETTER]

Lower case alphabet 9.57 ems

The most ancient materials employed for recording events were bricks, tiles, shells, and tables of stone. The modes of writing on these different substances were various: The tiles and brick were impressed with a stamp when in a soft state; the shells and tablets of stone were etched or graven, the figures or characters being cut in their surface, and in some cases also stained with various colors. It was by the ancient art of stamping that the walls, palaces, and towers of Babylon were covered with hieroglyphics, which have but recently been brought to light from under the immense mounds of Mesopotamia by Layard and other explorers. The patriarch Job, who is supposed to have lived about 2,300 years after the creation, exclaimed, "O that my words were now written! O that they were printed in a book! that they were graven with an iron pen and hid in the rock forever." Stung by the unjust accusation of his friends, he desires

The most ancient materials used for recording events were bricks, tiles, shells, and tables of stone. The modes of writing on these different substances were various. The tiles and brick were impressed with a stamp when in a soft state; the shells and tablets of stone were etched or graven, the figures or characters being cut in their surface, and in some cases also stained with various colors. It was by the ancient art of stamping that the walls, palaces, and towers of Babylon were covered with hieroglyphics, which have but recently been brought to light from under the immense mounds of Mesopotamia by Layard and other explorers. The patriarch Job, who is supposed to have lived about 2,300 years after the creation, exclaimed, "O that my words were now written! O that they were printed in a book! that they were graven with an iron

ABCDEFGHIJKLMNOPQRSTUVWXYZ&

abcdefghijklmnopqrstuvwxyz

1 2 3 4 5 6 7 8 9 0

, . : ; | ? (|) * ' ' _ _ _ - - - ¢ ¢ ¢ ¢ ¢ ¢ ¢ @ £ \$

[] ¼ ¼ ¼ ½ ½ ¾ ¾

Special set table characters Figures and figure space .0484; double figure space .0968; comma, period and quotations .0277. Unit system, ¼-point basis. These sizes will be sent unless otherwise ordered.

Alignment. This face aligns with all 8-point faces having low alignment except German.

Will run in all machines.

To avoid errors read notice on page six

MERGENTHALER LINOTYPE CO.

10-POINT GOTHIC CONDENSED NO. 2

[ONE-LETTER]

Lower case alphabet 3.63 ems

The most ancient materials employed for recording events were bricks, tiles, shells, and tables of stone. The modes of writing on these different substances were various. The tiles and brick were impressed with a stamp when in a soft state; the shells and tablets of stone were etched or graven, the figures or characters being cut in their surface, and in some cases also stained with various colors. It was by the ancient art of stamping that the walls, palaces, and towers of Babylon were covered with hieroglyphics, which have but recently been brought to light from under the immense mounds of Mesopotamia by Layard and other explorers. The patriarch, Job who is supposed to have lived about 2,300 years after the creation, exclaimed, "O that my words were

The most ancient materials used for recording events were bricks, tiles, shells, and tables of stone. The modes of writing on these different substances were various. The tiles and brick were impressed with a stamp when in a soft state; the shells and tablets of stone were etched or graven, the figures or characters being cut in their surface, and in some cases also stained with various colors. It was by the ancient art of stamping that the walls, palaces, and towers of Babylon were covered with hieroglyphics, which have but recently been brought to light from under the immense mounds of Mesopotamia by Layard

ABCDEFGHIJKLMNOPQRSTUVWXYZ&

abcdefghijklmnopqrstuvwxyz

1 2 3 4 5 6 7 8 9 0

, . : ; ! ? (|) * ' ' - _ _ fi ff ff ff ff tb @ £ \$

[] 1/8 1/4 3/8 1/2 5/8 3/4 7/8

Special set table characters. Figures and figure space .0553; double figure space .1107; comma, period, and quotations .0277. Unit system, 1/4-point basis. These sizes will be sent unless otherwise ordered.

Alignment. This face aligns with all 10-point one- and two-letter faces except German.

Will run in all machines.

To avoid errors read notice on page six

MERGENTHALER LINOTYPE CO.

12-POINT GOTHIC CONDENSED NO. 2
[ONE-LETTER]

Lower case alphabet 7.84 ems

The most ancient materials employed for recording events were bricks, tiles, shells, and tables of stone. The modes of writing on these different substances were various. The tiles and brick were impressed with a stamp when in a soft state; the shells and tablets of stone were etched or graven, the figures or characters being cut in their surface, and in some cases also stained with various colors. It was by the ancient art of stamping that the walls, palaces, and towers of Babylon were covered with hieroglyphics, which have but recently been brought to light from under the immense mounds of

The most ancient materials employed for recording events were bricks, tiles, shells, and tables of stone. The modes of writing on these different substances were various. The tiles and brick were impressed with a stamp when in a soft state; the shells and tablets of stone were etched or graven, the figures or characters being cut in their surface, and in some cases also stained with various colors. It was by the ancient art of stamp-

ABCDEFGHIJKLMNOPQRSTUVWXYZ&

abcdefghijklmnopqrstuvwxyz

1 2 3 4 5 6 7 8 9 0

, . : ; ! ? (|) * ' - _ _ _ fi ff fl fl th @ £ []

1/8 1/4 3/8 1/2 5/8 3/4 7/8

Special set table characters. Figures and figure space .0692; double figure space .1383; comma, period, and quotations .0346. Unit system, 1/4-point basis. These sizes will be sent unless otherwise ordered.

Alignment. This face aligns with all 12-point one- and two-letter faces except German.

Will run in all machines.

To avoid errors read notice on page six

SPECIMENS OF LINOTYPE FACES

**12-POINT
GOTHIC
CONDENSED NO. 2
One-Letter**

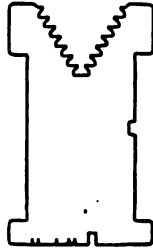

**SPECIAL
CHARACTERS**

Æ æ Œ œ

§ ¶ || † ‡ - /

1/3 2/3 1/5 2/5 3/5 4/5 1/6 5/6 1/4 1/2 3/4 1/8 1/16 1/32 1/64 1/128 1/256 1/512 1/1024

Superior: 1 2 3 4 5 6 7 8 9 0

☼ ☽ ☾ ☿ ♁ ♃ ♅ ♇ ♉ ♋ ♍ ♏ ♐ ♑ ♒ ♓
 ☿ ☽ ☾ ☿ ♁ ♃ ♅ ♇ ♉ ♋ ♍ ♏ ♐ ♑ ♒ ♓
 ≡ ℏ ℓ ℓ ℓ Δ □ ∠ ≤ ≥ √ < > ± ∓ ∴ ∵ ∶ ∷
 ☛ # ' " ° ° ° ° ° ° ° ° ° ° ☛
 ☛ 1 1 1 1 1 1 1 1 1 1 1 1 ☛

MERGENTHALER LINOTYPE CO.

14-POINT GOTHIC CONDENSED NO. 2
[ONE-LETTER]

Lower case alphabet 8.31 ems

The most ancient materials employed for recording events were bricks, tiles, shells, and tables of stone. The modes of writing on these different substances were various. The tiles and brick were impressed with a stamp when in a soft state; the shells and tablets of stone were etched or graven, the figures or characters being cut in their surface, and in some cases also stained with various colors. It was by the ancient art of stamping that the

The most ancient materials employed for recording events were bricks, tiles, shells, and tables of stone. The modes of writing on these different substances were various. The tiles and brick were impressed with a stamp when in a soft state; the shells and tablets of stone were graven, or etched, the figures or char-

ABCDEFGHIJKLMNOPQRSTUVWXYZ&

abcdefghijklmnopqrstuvwxyz

1 2 3 4 5 6 7 8 9 0

, . : ; ! ? (|) * ' - _ _ _ fi ff ff ff @ lb £ \$ []

1/8 1/4 3/8 1/2 5/8 3/4 7/8

Special set table characters. Figures and figure space .083; double figure space .166; comma, period, and quotations .0415. Unit system, 1/4-point basis. These sizes will be sent unless otherwise ordered.

Alignment. This face aligns with all 14-point one- and two-letter faces except German.

Will run in machines Nos. 2, 3, 4 and 5.

To avoid errors read notice on page six

SPECIMENS OF LINOTYPE FACES

**14-POINT
GOTHIC
CONDENSED NO. 2
One-Letter**

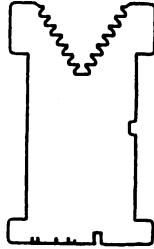

**SPECIAL
CHARACTERS**

Æ æ Œ œ

§ ¶ || † ‡ - /

1/3 2/3 1/5 2/5 3/5 4/5 1/6 5/6 1/8 1/4 3/8 1/2 5/8 3/4 7/8 1/3 2/3 1/5 2/5 3/5 4/5 1/6 5/6

MERGENTHALER LINOTYPE CO.

8-POINT GOTHIC NO. 3
[ONE-LETTER]

Lower case alphabet 14.48 ems

The most ancient materials used for recording events were bricks, tiles, shells, and tables of stone. The modes of writing on these different substances were various. The tiles and brick were impressed with a stamp when in a soft state; the shells and tablets of stone were etched or graven, the figures or characters being cut in their surface, and in some cases also stained with various colors. It was by the ancient art of stamping that the walls, palaces, and towers of Babylon were covered with hieroglyphics, which have but recently been brought to light from under the immense mounds of Mesopotamia by Layard and other explorers. The patriarch Job, who is supposed to have

The most ancient materials employed for recording events were bricks, tiles, shells, and tables of stone. The modes of writing on these different substances were various. The tiles and brick were impressed with a stamp when in a soft state; the shells and tablets of stone were etched or graven, the figures or characters being cut in their surface, and in some cases also stained with various colors. It was by the ancient art of stamping that the walls, palaces, and towers of Babylon were covered with hieroglyphics, having but recently been brought to light from under the immense mounds of

ABCDEFGHIJKLMNOPQRSTUVWXYZ&

abcdefghijklmnopqrstuvwxyz

1 2 3 4 5 6 7 8 9 0

, . : ; ! ? (|) * ' ' - _ _ _ fi fi ff ff m m lb @ & \$ []

1/8 1/4 3/8 1/2 5/8 3/4 7/8

Special set table characters. Figures and figure space .059; double figure space .118; comma, period, and quotations .0295. These sizes will be sent unless otherwise ordered.

Alignment. This face aligns with all 8-point one- and two-letter faces having high alignment except German.

Will run in all machines.

To avoid errors read notice on page six

MERGENTHALER LINOTYPE CO.

10-POINT GOTHIC NO. 3
[ONE-LETTER]

Lower case alphabet 13.66 ems

The most ancient materials used for recording events were bricks, tiles, shells, and tables of stone. The modes of writing on these different substances were various. The tiles and brick were impressed with a stamp when in a soft state; the shells and tablets of stone were etched or graven, the figures or characters being cut in their surface, and in some cases also stained with various colors. It was by the ancient art of stamping that the walls, palaces, and towers of Babylon were cov-

The most ancient materials employed for recording events were bricks, tiles, shells, and tables of stone. The modes of writing on these different substances were various. The tiles and brick were impressed with a stamp when in a soft state; the shells and tablets of stone were etched or graven, the figures or characters being cut in their surface, and in some cases also stained with various colors. It was by the ancient art of stamping that

ABCDEFGHIJKLMNOPQRSTUVWXYZ&

abcdefghijklmnopqrstuvwxyz

1 2 3 4 5 6 7 8 9 0

, . : ; ! ? (|) * ' ' - _ _ _ _ fi fl ff ffi ffl lb @ £ \$ []

1/8 1/4 3/8 1/2 5/8 3/4 7/8

Special set table characters. Figures and figure space .084; double figure space .168; comma, period, and quotations .042. These sizes will be sent unless otherwise ordered.

Alignment. This face aligns with all 10-point one- and two-letter faces except German.

Will run in all machines.

To avoid errors read notice on page six

SPECIMENS OF LINOTYPE FACES

10-POINT
GOTHIC NO. 3
One-Letter

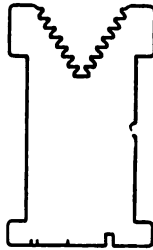

SPECIAL
CHARACTERS

Low Cap Accents—Regular mold may be used.

À É Í Ó Ñ Ò Ù

á é í ñ ó ú ü

Æ æ Œ œ

§ ¶ || † ‡ - † ‡

1/3 2/3 1/5 2/5 3/5 4/5 1/6 5/6

□ ◻ abcdefghijklmnopqrstuvwxyz abcdefghijklmnopqrstuvwxyz □ ◻

□ ◻ abcdefghijklmnopqrstuvwxyz abcdefghijklmnopqrstuvwxyz □ ◻

1234567890 + - x () ' ' ' h m a ! " : ; & ? [] / + - x () [] - . 1234567890

Piece Fractions—Upper half: 1234567890 Lower half: 1234567890

Figures for Piece Fractions: Upper: 1234567890 Lower: 1234567890

⊕ ⊙ ☾ ☽ ● ○ ⊗ ⊕ ⊗ ⊕ * † ‡ § ¶ ⋄ ⋆ ⋈ ⋉ ⋊ ⋋ ⋌ ⋍ ⋎ ⋏ ⋐ ⋑ ⋒ ⋓ ⋔ ⋕ ⋖ ⋗ ⋘ ⋙ ⋚ ⋛ ⋜ ⋝ ⋞ ⋟ ⋠ ⋡ ⋢ ⋣ ⋤ ⋥ ⋦ ⋧ ⋨ ⋩ ⋪ ⋫ ⋬ ⋭ ⋮ ⋯ ⋰ ⋱ ⋲ ⋳ ⋴ ⋵ ⋶ ⋷ ⋸ ⋹ ⋺ ⋻ ⋼ ⋽ ⋾ ⋿ ⅀ ⅁ ⅂ ⅃ ⅄ ⅅ ⅆ ⅇ ⅈ ⅉ ⅊ ⅋ ⅌ ⅍ ⅎ ⅏ ⅐ ⅑ ⅒ ⅓ ⅔ ⅕ ⅖ ⅗ ⅘ ⅙ ⅚ ⅛ ⅜ ⅝ ⅞ ⅟ Ⅰ Ⅱ Ⅲ Ⅳ Ⅴ Ⅵ Ⅶ Ⅷ Ⅸ Ⅹ Ⅺ Ⅻ Ⅼ Ⅽ Ⅾ Ⅿ ⅰ ⅱ ⅲ ⅳ ⅴ ⅵ ⅶ ⅷ ⅸ ⅹ ⅺ ⅻ ⅼ ⅽ ⅾ ⅿ Ⓚ Ⓛ Ⓜ Ⓝ Ⓞ Ⓟ Ⓠ Ⓡ Ⓢ Ⓣ Ⓤ Ⓥ Ⓦ Ⓧ Ⓨ Ⓩ ⓐ ⓑ ⓓ ⓔ ⓖ ⓗ ⓘ ⓙ ⓚ ⓛ ⓜ ⓝ ⓞ ⓟ ⓠ ⓡ ⓢ ⓣ ⓤ ⓥ ⓦ ⓧ ⓨ ⓩ ⓪ ⓫ ⓬ ⓭ ⓮ ⓯ ⓰ ⓱ ⓲ ⓳ ⓴ ⓵ ⓶ ⓷ ⓸ ⓹ ⓺ ⓻ ⓼ ⓽ ⓾ ⓿ Ⓐ Ⓑ Ⓒ Ⓓ Ⓔ Ⓕ Ⓖ Ⓗ Ⓘ Ⓚ Ⓛ Ⓜ Ⓝ Ⓞ Ⓟ Ⓠ Ⓡ Ⓢ Ⓣ Ⓤ Ⓥ Ⓦ Ⓧ Ⓨ Ⓩ ⓐ ⓑ ⓓ ⓔ ⓖ ⓗ ⓘ ⓙ ⓚ ⓛ ⓜ ⓝ ⓞ ⓟ ⓠ ⓡ ⓢ ⓣ ⓤ ⓥ ⓦ ⓧ ⓨ ⓩ ⓪ ⓫ ⓬ ⓭ ⓮ ⓯ ⓰ ⓱ ⓲ ⓳ ⓴ ⓵ ⓶ ⓷ ⓸ ⓹ ⓺ ⓻ ⓼ ⓽ ⓾ ⓿

Ⓚ Ⓛ Ⓜ Ⓝ Ⓞ Ⓟ Ⓠ Ⓡ Ⓢ Ⓣ Ⓤ Ⓥ Ⓦ Ⓧ Ⓨ Ⓩ ⓐ ⓑ ⓓ ⓔ ⓖ ⓗ ⓘ ⓙ ⓚ ⓛ ⓜ ⓝ ⓞ ⓟ ⓠ ⓡ ⓢ ⓣ ⓤ ⓥ ⓦ ⓧ ⓨ ⓩ ⓪ ⓫ ⓬ ⓭ ⓮ ⓯ ⓰ ⓱ ⓲ ⓳ ⓴ ⓵ ⓶ ⓷ ⓸ ⓹ ⓺ ⓻ ⓼ ⓽ ⓾ ⓿

Ⓚ Ⓛ Ⓜ Ⓝ Ⓞ Ⓟ Ⓠ Ⓡ Ⓢ Ⓣ Ⓤ Ⓥ Ⓦ Ⓧ Ⓨ Ⓩ ⓐ ⓑ ⓓ ⓔ ⓖ ⓗ ⓘ ⓙ ⓚ ⓛ ⓜ ⓝ ⓞ ⓟ ⓠ ⓡ ⓢ ⓣ ⓤ ⓥ ⓦ ⓧ ⓨ ⓩ ⓪ ⓫ ⓬ ⓭ ⓮ ⓯ ⓰ ⓱ ⓲ ⓳ ⓴ ⓵ ⓶ ⓷ ⓸ ⓹ ⓺ ⓻ ⓼ ⓽ ⓾ ⓿

Ⓚ Ⓛ Ⓜ Ⓝ Ⓞ Ⓟ Ⓠ Ⓡ Ⓢ Ⓣ Ⓤ Ⓥ Ⓦ Ⓧ Ⓨ Ⓩ ⓐ ⓑ ⓓ ⓔ ⓖ ⓗ ⓘ ⓙ ⓚ ⓛ ⓜ ⓝ ⓞ ⓟ ⓠ ⓡ ⓢ ⓣ ⓤ ⓥ ⓦ ⓧ ⓨ ⓩ ⓪ ⓫ ⓬ ⓭ ⓮ ⓯ ⓰ ⓱ ⓲ ⓳ ⓴ ⓵ ⓶ ⓷ ⓸ ⓹ ⓺ ⓻ ⓼ ⓽ ⓾ ⓿

Ⓚ Ⓛ Ⓜ Ⓝ Ⓞ Ⓟ Ⓠ Ⓡ Ⓢ Ⓣ Ⓤ Ⓥ Ⓦ Ⓧ Ⓨ Ⓩ ⓐ ⓑ ⓓ ⓔ ⓖ ⓗ ⓘ ⓙ ⓚ ⓛ ⓜ ⓝ ⓞ ⓟ ⓠ ⓡ ⓢ ⓣ ⓤ ⓥ ⓦ ⓧ ⓨ ⓩ ⓪ ⓫ ⓬ ⓭ ⓮ ⓯ ⓰ ⓱ ⓲ ⓳ ⓴ ⓵ ⓶ ⓷ ⓸ ⓹ ⓺ ⓻ ⓼ ⓽ ⓾ ⓿

Ⓚ Ⓛ Ⓜ Ⓝ Ⓞ Ⓟ Ⓠ Ⓡ Ⓢ Ⓣ Ⓤ Ⓥ Ⓦ Ⓧ Ⓨ Ⓩ ⓐ ⓑ ⓓ ⓔ ⓖ ⓗ ⓘ ⓙ ⓚ ⓛ ⓜ ⓝ ⓞ ⓟ ⓠ ⓡ ⓢ ⓣ ⓤ ⓥ ⓦ ⓧ ⓨ ⓩ ⓪ ⓫ ⓬ ⓭ ⓮ ⓯ ⓰ ⓱ ⓲ ⓳ ⓴ ⓵ ⓶ ⓷ ⓸ ⓹ ⓺ ⓻ ⓼ ⓽ ⓾ ⓿

Ⓚ Ⓛ Ⓜ Ⓝ Ⓞ Ⓟ Ⓠ Ⓡ Ⓢ Ⓣ Ⓤ Ⓥ Ⓦ Ⓧ Ⓨ Ⓩ ⓐ ⓑ ⓓ ⓔ ⓖ ⓗ ⓘ ⓙ ⓚ ⓛ ⓜ ⓝ ⓞ ⓟ ⓠ ⓡ ⓢ ⓣ ⓤ ⓥ ⓦ ⓧ ⓨ ⓩ ⓪ ⓫ ⓬ ⓭ ⓮ ⓯ ⓰ ⓱ ⓲ ⓳ ⓴ ⓵ ⓶ ⓷ ⓸ ⓹ ⓺ ⓻ ⓼ ⓽ ⓾ ⓿

Ⓚ Ⓛ Ⓜ Ⓝ Ⓞ Ⓟ Ⓠ Ⓡ Ⓢ Ⓣ Ⓤ Ⓥ Ⓦ Ⓧ Ⓨ Ⓩ ⓐ ⓑ ⓓ ⓔ ⓖ ⓗ ⓘ ⓙ ⓚ ⓛ ⓜ ⓝ ⓞ ⓟ ⓠ ⓡ ⓢ ⓣ ⓤ ⓥ ⓦ ⓧ ⓨ ⓩ ⓪ ⓫ ⓬ ⓭ ⓮ ⓯ ⓰ ⓱ ⓲ ⓳ ⓴ ⓵ ⓶ ⓷ ⓸ ⓹ ⓺ ⓻ ⓼ ⓽ ⓾ ⓿

MERGENTHALER LINOTYPE CO.

7-POINT GOTHIC NO. 4
[ONE-LETTER]

Lower case alphabet 14.62 ems

The most ancient materials used for recording events were bricks, tiles, shells, and tables of stone. The modes of writing on these different substances were various. The tiles and brick were impressed with a stamp when in a soft state; the shells and tablets of stone were etched or graven, the figures or characters being out in their surface, and in some cases also stained with various colors. It was by the ancient art of stamping that the walls palaces, and towers of Babylon were covered with hieroglyphics, which have but recently been brought to light from under the immense mounds of Mesopotamia by Layard and other explorers. The patriarch Job, who is supposed to have lived 2,300 years after the creation, exclaimed, "O that my words were now written! O that they were printed in a book! that they were graven with an iron pen, and hid in the rock forever!" Stung with the unjust

The most ancient materials employed for recording events, were bricks, tiles, shells, and tables of stone. The modes of writing on these different substances were various. The tiles and brick were impressed with a stamp when in a soft state; the shells and tablets of stone were etched or graven, the figures or characters being out in their surface, and in some cases also stained with various colors. It was by the ancient art of stamping that the walls, palaces, and towers of Babylon were covered with hieroglyphics, which have but recently been brought to light from under the immense mounds of Mesopotamia by Layard and other explorers. The patriarch Job, who is supposed to have lived 2,300 years after the creation, exclaimed, "O that my words

ABCDEFGHIJKLMNOPQRSTUVWXYZ&

abcdefghijklmnopqrstuvwxyz

1 2 3 4 5 6 7 8 9 0

, . : ; ! ? () * ' ' - - - ¢ ¢ ¢ ¢ ¢ ¢ ¢ @ £ \$ []

1/8 1/4 3/8 1/2 5/8 3/4 7/8

Special set table characters. Figures and figure space .056; double figure space .112; comma, period, and quotations .028; These sizes will be sent unless otherwise ordered.

Alignment. This face aligns with all 7-point one- and two-letter faces except German.

Will run in all machines.

To avoid errors read notice on page six

MERGENTHALER LINOTYPE CO.

6-POINT GOTHIC ITALIC NO. 4 [ONE-LETTER]

Lower case alphabet 14.16 ems

The most ancient materials employed for recording events were bricks, tiles, shells, and tables of stone. The modes of writing on these different substances were various. The tiles and brick were impressed with a stamp when in a soft state; the shells and tablets of stone were etched or graven, the figures or characters being cut in their surface, and in some cases also stained with various colors. It was by the ancient art of stamping that the walls, palaces, and towers of Babylon were covered with hieroglyphics, which have but recently been brought to light from under the immense mounds of Mesopotamia by Layard and other explorers. The patriarch Job, who is supposed to have lived about 2,300 years after the creation, exclaimed, "O that my words were now written! O that they were printed in a book! that they were graven with an iron pen, and hid in the rock forever." Stung by the unjust accusation of his friends, he desires to record his words that the generations following might see the justice of his cause. The English translation has given the allusion to printing to the text, the original word signifying rather to engrave on a

The most ancient materials employed for recording events were bricks, tiles, shells, and tables of stone. The modes of writing on these different substances were various. The tiles and brick were impressed with a stamp when in a soft state; the shells and tablets of stone were etched or graven, the figures or characters being cut in their surface, and in some cases also stained with various colors. It was by the ancient art of stamping that the walls, palaces, and towers of Babylon were covered with hieroglyphics, which have but recently been brought to light from under the immense mounds of Mesopotamia by Layard and other explorers. The patriarch Job, who is supposed to have lived about 2,300 years after the creation, exclaimed, "O that my words were now written! O that they were printed in a book! that they were graven with an iron pen, and hid in the rock forever." Stung by the unjust accusation of his friends he desires to record his words that the generations following might see the justice of his cause.

ABCDEFGHIJKLMNOPQRSTUVWXYZ&

abcdefghijklmnopqrstuvwxyz

1 2 3 4 5 6 7 8 9 0

. , : ; ! ? (|) * ' ' - - - - - ¢ ¤ £ ¤

True set table characters. Figures and en quad .0415; em quad .083; comma, period, and quotations .0277. Unit system, ¼-point basis. These sizes will be sent unless otherwise ordered.

Alignment. This face aligns with all 6-point one- and two-letter faces except German.

Will run in all machines.

To avoid errors read notice on page six

MERGENTHALER LINOTYPE CO.

8-POINT GOTHIC ITALIC NO. 4

[ONE-LETTER]

Lower case alphabet 13.15 ems

The most ancient materials employed for recording events were bricks, tiles, shells, and tables of stone. The modes of writing on these different substances were various. The tiles and brick were impressed with a stamp when in a soft state; the shells and tablets of stone were etched or graven, the figures or characters being cut in their surface, and in some cases also stained with various colors. It was by the ancient art of stamping that the walls and palaces of Babylon were covered with hieroglyphics, which have but recently been brought to light from under the immense mounds of Mesopotamia by Layard and other explorers. The patriarch Job, who is supposed to have lived 2,300 years after the creation, exclaimed, "O that my words were now written! O that they were printed in a book! that they were graven with an iron pen, and hid in the rock forever!" Stung with the unjust

The most ancient materials employed for recording events were bricks, tiles, shells, and tables of stone. The modes of writing on these different substances were various. The tiles and brick were impressed with a stamp when in a soft state; the shells and tablets of stone were etched or graven, the figures or characters being cut in their surface, and in some cases also stained with various colors. It was by the ancient art of stamping that the walls, palaces, and towers of Babylon were covered with hieroglyphics, which have but recently been brought to light from under the immense mounds of Mesopotamia by Layard

ABCDEFGHIJKLMN OPQRSTUVWXYZ&

abcdefghijklmno pqrstuvwxyz

1 2 3 4 5 6 7 8 9 0

. . . ; ! ? (|) - _ . . . fi fl ff ffi ffl lb @ £ \$

True set table characters. Figures and en quad .0553; em quad .1107; comma, period, and quotations .0277. Unit system, 1/4-point basis. These sizes will be sent unless otherwise ordered.

Alignment. This face aligns with all 8-point one- and two-letter faces having low alignment except German.

Will run in all machines.

To avoid errors read notice on page six

MERGENTHALER LINOTYPE CO.

12-POINT GOTHIC NO. 5
[ONE-LETTER]

Lower case alphabet 12.08 ems

The most ancient materials used for recording events were bricks, tiles, shells, and tables of stone. The modes of writing on these different substances were various. The tiles and brick were impressed with a stamp when in a soft state; the shells and tablets of stone were etched or graven, the figures or characters being cut in their surface, and in some cases also stained with various colors. It was by the art of stamping

The most ancient materials employed for recording events were bricks, tiles, shells, and tablets of stone. The modes of writing on these different substances were various. The tiles and brick were impressed with a stamp when in a soft state; the shells and tablets of stone were etched or graven, the figures or characters being cut in

ABCDEFGHIJKLMNOPQRSTUVWXYZ&
abcdefghijklmnopqrstuvwxyz

1 2 3 4 5 6 7 8 9 0

, . ; ; ! ? (|) * ' ' — — — fi fl ff ffi ffl tb @ £ \$ []
 $\frac{1}{8}$ $\frac{1}{4}$ $\frac{3}{8}$ $\frac{1}{2}$ $\frac{5}{8}$ $\frac{3}{4}$ $\frac{7}{8}$

Special set table characters. Figures and figure space .091; double figure space .182; comma, period, and quotations .0455. These sizes will be sent unless otherwise ordered.

Alignment. This face aligns with all 12-point one- and two-letter faces having low alignment, except German.

Will run in all machines.

To avoid errors read notice on page six

SPECIMENS OF LINOTYPE FACES

12-POINT
GOTHIC NO. 5
One-Letter

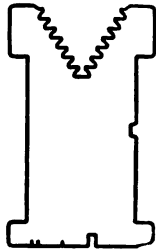

SPECIAL
CHARACTERS

Æ æ Œ œ

á à â ä ç é è ê ë ì í î ï ñ ó ò ô õ ú û ü

½ ¾ ⅓ ⅔ ⅕ ⅖ ⅗ ⅘

§ ¶ † ‡ − / ¢

Superior: 1 2 3 4 5 6 7 8 9 0

☼ ☺ ☾ ☽ ☾ ☽ ● ☉ ⊕ ⊗ ⚠ * ♀ ♀ † ‡
 ♂ ♂ Ω ℔ † ‡ ☽ ☽ † ‡ ♂ ♂ ♂ ♂ ♂ ♂ ♂ ♂ ♂ ♂
 ≡ ℔ ℔ ℔ ℔ Δ □ ∠ ≡ ≡ √ < > ± ∓ ∴ ∴ ∴ ∴
 ☛ # ' " ° " « » ¶ * ¶ ¼ ½ ¾ % % % % ☛
 ☛ ⋮ ⋮ ⋮ ⋮ ⋮ ⋮ ⋮ ⋮ ⋮ ⋮ ☛

MERGENTHALER LINOTYPE CO.

8-POINT ELZEVIR GOTHIC [ONE-LETTER]

Lower case alphabet 13.64 ems

The most ancient materials used for recording events were bricks, tiles, shells, and tables of stone. The modes of writing on these different substances were various. The tiles and brick were impressed with a stamp when in a soft state; the shells and tablets of stone were etched or graven, the figures or characters being cut in their surface, and in some cases also stained with various colors. It was by the ancient art of stamping that the walls, palaces, and towers of Babylon were covered with hieroglyphics, which have but recently been brought to light from under the immense mounds of Mesopotamia by Layard and other explorers. The patriarch Job, who is supposed to have lived about 2,300 years after the creation,

The most ancient materials employed for recording events were bricks, tiles, shells, and tables of stone. The modes of writing on these different substances were various. The tiles and brick were impressed with a stamp when in a soft state; the shells and tablets of stone were etched or graven, the figures or characters being cut in their surface, and in some cases also stained with various colors. It was by the ancient art of stamping that the walls, palaces, and towers of Babylon were covered with hieroglyphics, which have but recently

ABCDEFGHIJKLMNPOQRSTUVWXYZ&

abcdefghijklmnopqrstuvwxy z

1 2 3 4 5 6 7 8 9 0

, . : ; ! () * ' ' - — . . . fi fl ff ffi ffl fb @ £ \$ []

1/8 1/4 3/8 1/2 5/8 3/4 7/8

True set table characters. Figures and en quad .056; em quad .112; comma, period, and quotations .028. These sizes will be sent unless otherwise ordered.

Alignment. This face aligns with all 8-point one- and two-letter faces having low alignment except German.

Will run in all machines.

To avoid errors read notice on page six

MERGENTHALER LINOTYPE CO.

10-POINT ELZEVIK GOTHIC
[ONE-LETTER]

Lower case alphabet 14.04 ems

The most ancient materials used for recording events were bricks, tiles, shells, and tables of stone. The modes of writing on these different substances were various. The tiles and brick were impressed with a stamp when in a soft state; the shells and tablets of stone were etched or graven, the figures or characters being cut in their surface, and in some cases also stained with various colors. It was by the ancient art of stamping that the walls, palaces, and towers of Babylon

The most ancient materials employed for recording events were bricks, tiles, shells, and tablets of stone. The modes of writing on these different substances were various. The tiles and brick were impressed with a stamp when in a soft state; the shells and tablets of stone were etched or graven, the figures or characters being cut in their surface, and in some cases also

ABCDEFGHIJKLMNOPQRSTUVWXYZ&

abcdefghijklmnopqrstuvwxyz

1 2 3 4 5 6 7 8 9 0

, . : ; ! ? (|) * ' ' - — . . . fi fl ff ffi ffl lb @ £ \$ []

1/8 1/4 3/8 1/2 5/8 3/4 7/8

Special set table characters. Figures and figure space .077; double figure space .154; comma, period, and quotations .0385. These sizes will be sent unless otherwise ordered.

Alignment. This face aligns with all 10-point one- and two-letter faces except German.

Will run in all machines.

To avoid errors read notice on page six

MERGENTHALER LINOTYPE CO.

8-POINT ADMIRAL [ONE-LETTER]

Lower case alphabet 14.27 ems

The most ancient materials employed for recording events were bricks, tiles, shells, and tables of stone. The modes of writing on these different substances were various. The tiles and brick were impressed with a stamp when in a soft state; the shells and tablets of stone were etched or graven, the figures or characters being cut in their surface, and in some cases also stained with various colors. It was by the ancient art of stamping that the walls, palaces, and towers of Babylon were covered with hieroglyphics, which have but recently been brought to light from under the great mounds of Mesopotamia by Layard and other explorers. The patriarch Job, who is supposed to have lived about 2,300 years after the creation, exclaimed, "O that my words were now written! O that they were printed in a book! that they were graven with an iron pen, and hid in the rock forever!" Stung

The most ancient materials employed for recording events were bricks, tiles, shells, and tables of stone. The modes of writing on these different substances were various. The tiles and brick were impressed with a stamp when in a soft state; the shells and tablets of stone were etched or graven, the figures or characters being cut in their surface, and in some cases also stained with various colors. It was by the ancient art of stamping that the walls, palaces, and towers of Babylon were covered with hieroglyphics, which have but recently been brought to light from under the immense mounds of Mesopotamia

ABCDEFGHIJKLMNPOQRSTUVWXYZ&

abcdefghijklmnopqrstuvwxy

1 2 3 4 5 6 7 8 9 0

. . . ; ! ? (|) * ' ' . — . . . n n n n n n n n @ £ \$ []

¼ ½ ¾ ⅓ ⅔ ⅖ ⅙

Special set table characters. Figures and figure space .0692; double figure space .1383; comma, period, and quotations .0346. Unit system ¼-point basis. These sizes will be sent unless otherwise ordered.

Alignment. This face aligns with all 8-point faces having low alignment except German.

Will run in all machines.

To avoid errors read notice on page six

MERGENTHALER LINOTYPE CO.

8-POINT ADMIRAL

[ONE-LETTER]

Lower case alphabet 14.27 ems

The most ancient materials employed for recording events were bricks, tiles, shells, and tables of stone. The modes of writing on these different substances were various. The tiles and brick were impressed with a stamp when in a soft state; the shells and tablets of stone were etched or graven, the figures or characters being cut in their surface, and in some cases also stained with various colors. It was by the ancient art of stamping that the walls, palaces, and towers of Babylon were covered with hieroglyphics, which have but recently been brought to light from under the great mounds of Mesopotamia by Layard and other explorers. The patriarch Job, who is supposed to have lived about 2,300 years after the creation, exclaimed, "O that my words were now written! O that they were printed in a book! that they were graven with an iron pen, and hid in the rock forever!" Stung

The most ancient materials employed for recording events were bricks, tiles, shells, and tables of stone. The modes of writing on these different substances were various. The tiles and brick were impressed with a stamp when in a soft state; the shells and tablets of stone were etched or graven, the figures or characters being cut in their surface, and in some cases also stained with various colors. It was by the ancient art of stamping that the walls, palaces, and towers of Babylon were covered with hieroglyphics, which have but recently been brought to light from under the immense mounds of Mesopotamia

ABCDEFGHIJKLMNPOQRSTUVWXYZ&

abcdefghijklmnopqrstuvwxy

1 2 3 4 5 6 7 8 9 0

. . . ; ! ? (|) * ' ' . — . . . n n n n n n n n @ £ \$ []

¼ ½ ¾ ⅓ ⅔ ⅖ ⅙

Special set table characters. Figures and figure space .0692; double figure space .1383; comma, period, and quotations .0346. Unit system ¼-point basis. These sizes will be sent unless otherwise ordered.

Alignment. This face aligns with all 8-point faces having low alignment except German.

Will run in all machines.

To avoid errors read notice on page six

MERGENTHALER LINOTYPE CO.

6-POINT ROYAL GOTHIC
[ONE-LETTER]

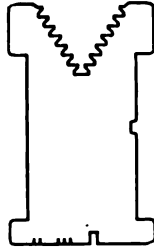

THE MOST ANCIENT MATERIALS EMPLOYED FOR RECORDING EVENTS WERE BRICKS, TILES, SHELLS AND TABLES OF STONE. THE MODES OF WRITING ON THESE DIFFERENT SUBSTANCES WERE VARIOUS. THE TILES AND BRICK WERE IMPRESSED WITH A STAMP WHEN IN A SOFT STATE; THE SHELLS AND TABLETS OF STONE WERE ETCHED OR GRAVEN, THE FIGURES OR CHARACTERS BEING CUT IN THEIR SURFACE AND IN SOME CASES STAINED WITH VARIOUS COLORS. IT WAS BY THE ANCIENT ART OF STAMPING THAT THE WALLS, PALACES, AND TOWERS OF BABYLON WERE COVERED WITH HIEROGLYPHICS, WHICH HAVE BUT RECENTLY BEEN BROUGHT TO

THE MOST ANCIENT MATERIALS USED FOR RECORDING EVENTS WERE BRICKS, TILES, SHELLS, AND TABLES OF STONE. THE MODES OF WRITING ON THESE DIFFERENT SUBSTANCES WERE VARIOUS. THE TILES AND BRICK WERE IMPRESSED WITH A STAMP WHEN IN A SOFT STATE; THE SHELLS AND TABLETS OF STONE WERE ETCHED OR GRAVEN, THE FIGURES OR CHARACTERS BEING CUT IN THEIR SURFACE, AND IN SOME CASES ALSO STAINED WITH VARIOUS COLORS. IT WAS BY

ABCDEFGHIJKLMN OPQRSTUVWXYZ&

1 2 3 4 5 6 7 8 9 0

o , . ! ; ' ' - \$ % ! ? () 1/2 — —

Special set table characters. Figures and figure space .077; double figure space .154; comma, period, and quotations .0385. These sizes will be sent unless otherwise ordered.

Alignment. This face has a special alignment—the caps aligning at the bottom with caps of 7-point No. 1.

Will run in all machines.

To avoid errors read notice on page six

MERGENTHALER LINOTYPE CO.

8-POINT ROYAL GOTHIC
[ONE-LETTER]

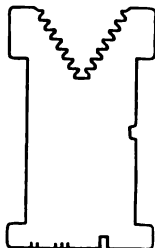

THE MOST ANCIENT MATERIALS USED FOR RECORDING EVENTS WERE BRICKS, TILES, SHELLS, AND TABLES OF STONE. THE MODES OF WRITING ON THESE SUBSTANCES WERE VARIOUS. THE TILES AND BRICK WERE IMPRESSED WITH A STAMP WHEN IN A SOFT STATE; THE SHELLS AND TABLETS OF STONE WERE ETCHED OR GRAVEN, THE FIGURES OR CHARACTERS BEING CUT IN THEIR SURFACE, AND IN SOME CASES ALSO STAINED WITH

THE MOST ANCIENT MATERIALS EMPLOYED FOR THE RECORDS OF EVENTS WERE BRICKS, TILES, SHELLS, AND TABLES OF STONE. THE WAYS OF WRITING ON THESE SUBSTANCES WERE MANY. THE TILES AND BRICK WERE IMPRESSED WITH A STAMP WHEN IN A SOFT STATE; THE SHELLS AND TABLETS WERE ETCHED OR GRAVEN, THE

**1 2 3 4 5 6 7 8 9 0
ABCDEFGHIJKLMN OPQRSTUVWXYZ &
c . : ; ' ' - 8 £**

Alignment. This face aligns with all 9-point one- and two-letter faces except German.
Will run in all machines.

To avoid errors read notice on page six

MERGENTHALER LINOTYPE CO.

10-POINT CONDENSED ANTIQUE
[ONE-LETTER]

Lower case alphabet 10.80 ems

The most ancient materials used for recording events were bricks, tiles, shells, and tables of stone. The modes of writing on these different substances were various. The tiles and brick were impressed with a stamp when in a soft state; the shells and tablets of stone were etched or graven, the figures or characters being cut in their surface, and in some cases also stained with various colors. It was by the ancient art of stamping that the walls, palaces, and towers of Babylon were covered with hieroglyphics, which have but recently been brought to light from under the immense mounds of Mesopotamia, by Layard and other explorers. The patriarch Job, who is

The most ancient materials employed for recording events were bricks, tiles, shells, and tables of stone. The modes of writing on these different substances were various. The tiles and brick were impressed with a stamp when in a soft state; the shells and tablets of stone were etched or graven, the figures or characters being cut in their surface, and in some cases also stained with various colors. It was by the ancient art of stamping that the walls, palaces, and towers of Babylon were covered with hieroglyph-

ABODEFGHIJKLMNOPQRSTUVWXYZ&

abcdefghijklmnopqrstuvwxyz

1 2 3 4 5 6 7 8 9 0

, . : ; ! ? (|) * ' ' - _ . . . fi ff fl fl fl lb @ £ \$ []

1/8 1/4 3/8 1/2 5/8 3/4 7/8

True set table characters. Figures and en quad .070; em quad .140; comma, period, and quotations .035. These sizes will be sent unless otherwise ordered.

Alignment. This face aligns with all 10-point one- and two-letter faces except German.

Will run in all machines.

To avoid errors read notice on page six

MERGENTHALER LINOTYPE CO.

12-POINT CONDENSED ANTIQUE [ONE-LETTER]

Lower case alphabet 11.42 ems

The most ancient materials employed for recording events were bricks, tiles, shells, and tables of stone. The modes of writing on these different substances were various. The tiles and brick were impressed with a stamp when in a soft state; the shells and tablets of stone were etched or graven, the figures or characters being cut in their surface, and in some cases also stained with various colors. It was by the ancient art of stamping that the walls, palaces,

The most ancient materials used for recording events were bricks, tiles, shells, and tables of stone. The modes of writing on these different substances were various. The tiles and brick were impressed with a stamp when in a soft state; the shells and tablets of stone were etched or graven, the figures or characters being cut in their surface, and

ABCDEFGHIJKLMNOPQRSTUVWXYZ&

abcdefghijklmnopqrstuvwxyz

1 2 3 4 5 6 7 8 9 0

, . : ; ! ? (|) * ' - _ _ _ fi ff ffi fff ffi lb @ £ \$ []

1/8 1/4 3/8 1/2 5/8 3/4 7/8

True set table characters. Figures and en quad .084; em quad .168; comma, period, and quotations .042. These sizes will be sent unless otherwise ordered.

Alignment. This face aligns with all 12-point one- and two-letter faces except German.

Will run in all machines.

To avoid errors read notice on page six

MERGENTHALER LINOTYPE CO.

10-POINT BERLIN ANTIQUE

[ONE-LETTER]

Lower case alphabet 13.58 ems

The most ancient materials employed for recording events were bricks, tiles, shells, and tables of stone. The modes of writing on these different substances were various. The tiles and brick were impressed with a stamp when in a soft state; the shells and tablets of stone were etched or graven, the figures or characters being cut in their surface, and in some cases stained with various colors. It was by the ancient art of stamping that the walls, palaces, and towers of Babylon were covered with hieroglyphics, which have but recently been brought to light

The most ancient materials used for recording events were bricks, tiles, shells, and tables of stone. The modes of writing on these different substances were various. The tiles and brick were impressed with a stamp when in a soft state; the shells and tablets of stone were etched or graven, the figures or characters being cut in their surface, and in many cases also stained with various colors. It was by the ancient art

ABCDEFGHIJKLMNOPQRSTUVWXYZ&

abcdefghijklmnopqrstuvwxyz

1 2 3 4 5 6 7 8 9 0

, . : ; ! ? (|) * ' ' - — . . . fi fl ff ffi ffl lb £ \$ @ []

1/8 1/4 3/8 1/2 5/8 3/4 7/8

Special set table characters. Figures and figure space .077; double figure space .154; comma, period, and quotations .0385. These sizes will be sent unless otherwise ordered.

Alignment. This face aligns with all 10-point one- and two-letter faces except German.

Will run in all machines.

To avoid errors read notice on page six

MERGENTHALER LINOTYPE CO.

12-POINT BERLIN ANTIQUE
[ONE-LETTER]

Lower case alphabet 14.19 ems

The most ancient materials employed for recording events were bricks, tiles, shells, and tables of stone. The modes of writing on these different substances were various. The tiles and brick were impressed with a stamp when in a soft state; the shells and tablets of stone were etched or graven, the figures or characters being cut in their surface, and in some cases also stained with various colors. It was by the

The most ancient materials used for recording events were bricks, tiles, shells, and tables of stone. The modes of writing on these different substances were various. The tiles and brick were stamped when in a soft state; the shells and tablets of stone were etched

ABCDEFGHIJKLMNOPQRSTUVWXYZ&

abcdefghijklmnopqrstuvwxyz

1 2 3 4 5 6 7 8 9 0

, . : ; ! ? () * ' ' - — . . . fi fl ff ffi ffl lb @ £ \$ []

$\frac{1}{8}$ $\frac{1}{4}$ $\frac{3}{8}$ $\frac{1}{2}$ $\frac{5}{8}$ $\frac{3}{4}$ $\frac{7}{8}$

True set table characters. Figures and en quad .084; em quad .168; comma, period, and quotations .042. These sizes will be sent unless otherwise ordered.

Alignment. This face aligns with all 12-point one- and two-letter faces except German.

Will run in machines Nos. 2, 3, 4 and 5

MERGENTHALER LINOTYPE CO.

7-POINT ANTIQUE NO. 1 [ONE-LETTER]

Lower case alphabet 15.38 ems

The most ancient materials employed for recording events were bricks, tiles, shells, and tables of stone. The modes of writing on these different substances were various. The tiles and brick were impressed with a stamp when in a soft state; the shells and tablets of stone were etched or graven, the figures or characters being cut in their surface, and in some cases also stained with various colors. It was by the ancient art of stamping that the walls, and palaces of Babylon were covered with hieroglyphics, which have but recently been brought to light from under the immense mounds of Mesopotamia by Layard and other explorers. The patriarch Job, who is supposed to have lived about 2,300 years after the creation, exclaimed, "O that my words were now written! O that they were printed in a book! that they were graven with an iron pen, and hid in the rock forever!" Stung

The most ancient materials employed for recording events were bricks, tiles, shells, and tables of stone. The modes of writing on these different substances were various. The tiles and brick were impressed with a stamp when in a soft state; the shells and tablets of stone were etched or graven, the figures or characters being cut in their surface, and in some cases also stained with various colors. It was by the ancient art of stamping that the walls, palaces, and towers of Babylon were covered with hieroglyphics, which have but recently been brought to light from under the immense mounds of Mesopotamia by Layard and other explorers. The patriarch Job, who is supposed to have lived

ABCDEFGHIJKLMN OPQRSTUVWXYZ&

abcdefghijklmnopqrstuvwxyz

1 2 3 4 5 6 7 8 9 0

, . : ; ! ? (|) * ' ' - . . . fi ff ffi ffl @ £ \$ []

¼ ½ ¾ ⅓ ⅔ ⅖ ⅘

Special set table characters. Figures and figure space .0553; double figure space .1107; comma, period, and quotations .0277. Unit system, ¼-point basis. These sizes will be sent unless otherwise ordered.

Substitute table characters for use with this face can be had as follows: 7-point Antique No. 1 Modernized figures.—Figures and figure space .0553; double figure space .1107.

Alignment. This face aligns with all 7-point one- and two-letter faces and all 8-point faces having high alignment.

Will run in all machines.

To avoid errors read notice on page six

SPECIMENS OF LINOTYPE FACES

**7-POINT
ANTIQUE NO. 1
One-Letter**

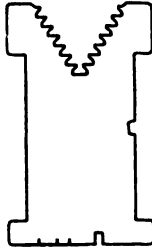

**SPECIAL
CHARACTERS**

High Cap Accents—These require a special mold.

Á Ä Ç É Í Ó Õ Ú

á à ä ç é ê ë ì í î ï ñ ò ó ô õ ú û ü

Æ æ Œ œ

§ ¶ || † ‡ - / - - -

3 3 B D

1/3 2/3 1/2 3/4 5/8 3/8 1/4 1/8 1/16 1/32 1/64 1/128 1/256 1/512 1/1024

1234567890 abcdefghijklmnopqrstuvwxyz abcdefghijklmnopqrstuvwxyz 1234567890

abcdefghijklmnopqrstuvwxy abcdefghijklmnopqrstuvwxy

Piece Fractions—Upper half: 1 2 3 4 5 6 7 8 9 9 Lower half: 1 2 3 4 5 6 7 8 6

Plain Figures for Piece Fractions—Upper: 1234567890 Lower: 1234567890



MERGENTHALER LINOTYPE CO.

8-POINT ANTIQUE NO. 1

[ONE-LETTER]

Lower case alphabet 14.88 ems

The most ancient materials used for recording events were bricks, tiles, shells, and tables of stone. The modes of writing on these different substances were various. The tiles and brick were impressed with a stamp when in a soft state; the shells and tablets of stone were etched or graven, the figures or characters being cut in their surface, and in some cases also stained with various colors. It was by the ancient art of stamping that the walls, palaces, and towers of Babylon were covered with hieroglyphics, which have but recently been brought to light from under the immense mounds of Mesopotamia by Layard and other explorers. The patriarch Job, who is supposed to have lived about 2,300 years after the creation, exclaimed, "O!

The most ancient materials used for recording events were bricks, tiles, shells, and tables of stone. The modes of writing on these different substances were various. The tiles and brick were impressed with a stamp when in a soft state; the shells and tablets of stone were etched or graven, the figures or characters being cut in their surface, and in some cases also stained with various colors. It was by the ancient art of stamping that the walls, palaces, and towers of Babylon were covered with hieroglyphics, which have but recently been brought to light from under the immense mounds of Mesopotamia by

ABCDEFGHIJKLMNOPQRSTUVWXYZ&

abcdefghijklmnopqrstuvwxyz

1 2 3 4 5 6 7 8 9 0

, . : ; ! ? () * ' - . . . fi ff ffi ffl lb @ £ \$ []

1/8 1/4 3/8 1/2 5/8 3/4 7/8

Special set table characters. Figures and figure space .059; double figure space .118; comma, period, and quotations .0295. These sizes will be sent unless otherwise ordered.

Substitute table characters for use with this face can be had as follows: 8-point Antique No. 1 Modernized figures.—Figures and figure space .059; double figure space .118; comma, period, and quotations .0295.

Alignment. This face aligns with all 8-point one- and two-letter faces having low alignment except German.
Will run in all machines.

To avoid errors read notice on page six

MERGENTHALER LINOTYPE CO.

10-POINT ANTIQUE NO. 1

[ONE-LETTER]

Lower case alphabet 13.54 ems

The most ancient materials employed for recording events were bricks, tiles, shells, and tables of stone. The modes of writing on these different substances were various. The tiles and brick were impressed with a stamp when in a soft state; the shells and tablets of stone were etched or graven, the figures or characters being cut in their surface, and in some cases also stained with various colors. It was by the ancient art of stamping that the walls, palaces, an towers of Babylon were covered with hieroglyphics, which have but recently been brought

The most ancient materials used for recording events were bricks, tiles, shells, and tables of stone. The modes of writing on these different substances were various. The tiles and brick were stamped when in a soft state; the shells and tablets of stone were etched or graven the figures or characters being cut in their surface, and in some cases also stained with various colors. It was by

ABCDEFGHIJKLMNOPQRSTUVWXYZ&

abcdefghijklmnopqrstuvwxyz

1 2 3 4 5 6 7 8 9 0

, . : ; ! ? (|) * ' - . . . fi fl ff ffi ffl lb £ \$ @ []

1/8 1/4 3/8 1/2 5/8 3/4 7/8

True set table characters. Figures and en quad .070; em quad .140; comma, period, and quotations .035. These sizes will be sent unless otherwise ordered.

Substitute table characters for use with this face can be had as follows: 10-point Antique No. 1 Modernized figures.—Figures and en quad .070; em quad .140.

Alignment. This face aligns with all 10-point one- and two-letter faces except German.

Will run in all machines.

To avoid errors read notice on page six

MERGENTHALER LINOTYPE CO.

8-POINT LATIN ANTIQUE [ONE-LETTER]

Lower case alphabet 18.88 ems

The most ancient materials employed for recording events were bricks, tiles, shells, and tables of stone. The modes of writing on these substances were varied. The tiles and brick were impressed with a stamp when in a soft state; the shells and tablets of stone were etched or graven, the figures or characters being cut in their surface, and in some cases also stained with various colors. It was by the ancient art of stamping that the walls, palaces, and towers of Babylon were covered with hieroglyphics, which have but recently been brought to light from under the immense mounds of Mesopotamia, by Layard and other

The most ancient materials used for recording events were bricks, tiles, shells and tables of stone. The modes of writing on these different substances varied. The tiles and brick were impressed with a stamp when in a soft state; the shells and tablets of stone were etched or graven, the figures or characters being carved in their surface, and in some cases also stained with various colors. It was by the ancient art of stamping that the walls, palaces, and towers of Baby-

ABCDEFGHIJKLMNOPQRSTUVWXYZ&

abcdefghijklmnopqrstuvwxyz

1 2 3 4 5 6 7 8 9 0

, . : ; ! ? () * ' ' - - . . fl fl ff fl ff lb @ £ \$

[] à á â ã ä å æ ç

Special set table characters. Figures and figure space .0968; comma, period, and quotations .0484. Unit system, ¼-point basis.

Alignment. This face aligns with all 8-point one- and two-letter faces having low alignment except German.

Will run in all machines.

To avoid errors read notice on page six

MERGENTHALER LINOTYPE CO.

10-POINT LATIN ANTIQUE
[ONE-LETTER]

Lower case alphabet 17.38 ems

The most ancient materials used in recording events were tablets of stone, bricks, tiles, and shells. The modes of writing on these different substances were various. The tiles and brick were impressed with a stamp when in a soft state; the shells and tablets of stone were etched or graven, the figures or characters being cut in their surface, and in some cases also stained with various colors. It was by the ancient art of stamping that the walls, palaces,

The most ancient materials used for recording events were bricks, tiles, shells and tables of stone. The modes of writing on these different substances were various. The tiles and brick were impressed with a stamp when in a soft state; the shells and tables of stone were etched or graven, the figures or characters

,. : ; ! ? () * ' - _ . fi fl ff ffi ffl fb £ \$ @ []
ABCDEF GHIJK LMNOP QRSTUVW XYZ
abc defghijklm nopqrstuvwxyz
1 2 3 4 5 6 7 8 9 0
1 1 3 1 5 3 7

Special set table characters. Figures and figure space .1107; comma, period, and quotations .0553. Unit system, 1/4-point basis. These sizes will be sent unless otherwise ordered.

Alignment. This face aligns with all 10-point one- and two-letter faces except German.

Will run in machines Nos. 2, 3, 4 and 5.

To avoid errors read notice on page six

MERGENTHALER LINOTYPE CO.

10-POINT LAW ITALIC
[ONE-LETTER]

Lower case alphabet 14.02 ems

The most ancient materials used for recording events were bricks, tiles, shells, and tables of stone. The tiles and brick were impressed with a stamp when in a soft state; the shells and tablets of stone were etched or graven, the figures or characters being cut in their surface, and in some cases also stained with various colors. It was by the ancient art of stamping that the walls, palaces, and towers of Babylon were covered with hieroglyphics, which have but recently been brought to light from under the immense mounds of Mesopotamia by Layard and other explorers. The patriarch Job, who is

The most ancient materials used to record events were bricks, tiles, shells, and tables of stone. The modes of writing on these different substances were various. The tiles and brick were impressed with a stamp when in a soft state; the shells and tablets of stone were etched or graven, the figures or characters being cut in their surface, and in some cases also stained with various colors.

ABCDEFGHIJKLMN OPQRSTUVWXYZ &
abcdefghijklmnopqrstu vwxyz
1 2 3 4 5 6 7 8 9 0
. . . ; ! ? (|) * ' ' - — . . . fi fl ff ffi ffl lb @ £ \$ []

Special set table characters. Figures and figure space .084; double figure space .168; comma, period, and quotations .042. These sizes will be sent unless otherwise ordered.
Alignment. This face aligns with all 10-point one- and two-letter faces except German.
Will run in all machines.

To avoid errors read notice on page six

MERGENTHALER LINOTYPE CO.

12-POINT LAW ITALIC
[ONE-LETTER]

Lower case alphabet 14.51 ems

The most ancient materials employed for recording events were bricks, tiles, shells, and tables of stone. The modes of writing on these different substances varied. The tiles and brick were impressed with a stamp when in a soft state; the shells and tablets of stone were etched or graven, the figures or characters being cut in their surface, and in some cases also

The most ancient materials employed for recording events were bricks, shells, tiles, and tables of stone. The modes of writing on these different substances varied. The tiles and the brick were impressed with a stamp when in a soft state; the shells and tablets of stone were etched or

ABCDEFGHIJKLMNOPQRSTUVWXYZ&

abcdefghijklmnopqrstuvwxy

1 2 3 4 5 6 7 8 9 0

, . : ; ! ? (|) * ' — . . . fi fl ff ffi ffl lb @ £ \$ []

1/8 1/4 3/8 1/2 5/8 3/4 7/8

Special set table characters. Figures and figure space .098; comma, period, and quotations .049. These sizes will be sent unless otherwise ordered.

Alignment. This face aligns with all 12-point one- and two-letter faces except German.

Will run in machines Nos. 2, 3, 4 and 5.

To avoid errors read notice on page six

MERGENTHALER LINOTYPE CO.

12-POINT STENOGRAP TYPEWRITER
[ONE-LETTER]

Lower case alphabet 15.48 ems

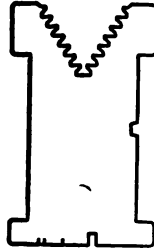

THE MOST ancient materials employed for recording events were bricks, tiles, shells, and tablets of stone. The modes of writing on these different substances were various. The tiles and brick were impressed with a stamp when in a soft state; the shells and tablets of stone were etched or graven, the figures

ABCDEFGHIJKLMN OPQRSTUVWXYZ &
abcdefghijklmnopqrstu vwxyz
, . : ; ! ? () * ' ' - - 1 2 3 4 5 6 7 8 9 0
¼ ½ ¾ ¼ ½ @ £ / \$ ¢ % # []

Low Cap Accents—Regular mold may be used.

Á É Í Ñ Ó Ú Û
á ä é í ñ ó ö ü ; ¿

Special set table characters. Figures and figure space .100; comma, period, and quotations .100 These sizes will be sent unless otherwise ordered.

Alignment. This face aligns with all 12-point one- and two-letter faces except German.

Will run in machines Nos. 2, 3, 4 and 5.

To avoid errors read notice on page six

SPECIMENS OF LINOTYPE FACES

12-POINT REMINGTON TYPEWRITER
[ONE-LETTER]

Lower case alphabet 14.97 ems

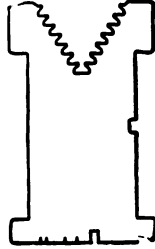

THE MOST ancient materials
employed for recording events
were bricks, tiles, shells, and
tablets of stone. The modes of
writing on these different sub-
stances were various. The tiles
and brick were impressed with a
stamp when in a soft state; the
shells and tablets of stone were
etched or graven, the figures
or characters being cut in their

ABCDEFGHIJKLMNOPQRSTUVWXYZ&
abcdefghijklmnopqrstuvwxyz
, . : ; ! ? () * ' " - - 1 2 3 4 5 6 7 8 9 0
¼ ⅓ ⅔ ½ ⅝ ¾ ⅞ lb @ £ / \$ ¢ % # []

Special set table characters. Figures an figure space .09675; comma and period .09675. These sizes will be sent unless otherwise ordered.

Alignment. This face aligns with all 12-point one- and two-letter faces except German.

Will run in machines Nos. 2, 3, 4 and 5.

To avoid errors read notice on page six

MERGENTHALER LINOTYPE CO.

8-POINT UNILINE

[ONE-LETTER]

Lower case alphabet 12.29 ems

The most ancient materials used for recording events were bricks, tiles, shells, and tables of stone. The modes of writing on these different substances were various. The tiles and brick were impressed with a stamp when in a soft state; the shells and tablets of stone were etched or graven, the figures or characters being cut in their surface, and in some cases also stained with various colors. It was by the ancient art of stamping that the walls, palaces, and towers of Babylon were covered with hieroglyphics, which have but recently been brought to light from under the immense mounds of Mesopotamia by Layard and other explorers. The patriarch Job, who is supposed to have lived about 2,300 years after the creation, exclaimed, "O that my words were now written! O that they were printed in a book! that they were graven with an iron pen and hid in the rock

The most ancient materials used for recording events were bricks, tiles, shells, and tablets of stone. The modes of writing on these different substances were various. The tiles and brick were impressed with a stamp when in a soft state; the shells and tablets of stone were etched or graven, the figures or characters being cut in their surface, and in some cases also stained with various colors. It was by the ancient art of stamping that the walls, palaces, and towers of Babylon were covered with hieroglyphics, which have but recently been brought to light from under the immense mounds of Mesopotamia by Layard and other explorers. The patriarch Job, who is supposed to have lived about 2,300 years after the creation, exclaimed,

ABCDEFGHIJKLMNOPQRSTUVWXYZ&

abcdefghijklmnopqrstuvwxyz

1 2 3 4 5 6 7 8 9 0

, . : ; ! ? () * ' - — . . . fi fl ff ffi ffl lb @ £ \$ []

¼ ½ ¾ ⅓ ⅔ ⅛ ⅜ ⅝ ⅞

True set table characters. Figures and en quad .0553; em quad .1107; comma, period, and quotations .0277. Type founders' point system. These sizes will be sent unless otherwise ordered.

Alignment. This face aligns with all 8-point one- and two-letter faces having low alignment except German.

Will run in all machines.

To avoid errors read notice on page six

MERGENTHALER LINOTYPE CO.

10-POINT UNILINE

[ONE-LETTER]

Lower case alphabet 12.68 ems

The most ancient materials employed for recording events were bricks, tiles, shells, and tables of stone. The modes of writing on these different substances were various. The tiles and brick were impressed with a stamp when in a soft state; the shells and tablets of stone were etched or graven, the figures or characters being cut in their surface, and in some cases stained with various colors. It was by the ancient art of stamping that the walls, palaces, and towers of Babylon were covered with hieroglyphics, which have but recently been brought to light from under the immense mounds of Mesopotamia, by Layard and other explorers. The

The most ancient materials used for recording events were bricks, tiles, shells, and tables of stone. The methods used for writing on these different substances were various. The tiles and brick were impressed with a stamp when in a soft state; the shells and the tablets of stone were etched or graven, the figures or characters being cut in their surface, and in some cases also stained with various colors. It was by the ancient art of stamping that the walls, pal-

ABCDEFGHIJKLMNOPQRSTUVWXYZ&

abcdefghijklmnopqrstuvwxyz

1 2 3 4 5 6 7 8 9 0

. . . ; ! ? (|) * ' ' - — . . . fi fl ff ffi ffl lb @ £ \$ []

$\frac{1}{8}$ $\frac{1}{4}$ $\frac{3}{8}$ $\frac{1}{2}$ $\frac{5}{8}$ $\frac{3}{4}$ $\frac{7}{8}$

Special set table characters. Figures and figure space .0692; double figure space .1383; comma, period, and quotations .0345. These sizes will be sent unless otherwise ordered.

Alignment. This face aligns with all 10-point one- and two-letter faces except German.

Will run in all machines.

To avoid errors read notice on page six

MERGENTHALER LINOTYPE CO.

12-POINT UNILINE
[ONE-LETTER]

Lower case alphabet 13.61 ems

The most ancient materials employed for recording events were bricks, tiles, shells, and tables of stone. The modes of writing on these different substances were various. The tiles and brick were impressed with a stamp when in a soft state; the shells and tablets of stone were etched or graven, the figures or characters being cut in their surface, and in some cases also stained with various colors. It was by the ancient art of

The most ancient materials used for recording events were bricks, tiles, shells, and tables of stone. The modes of writing on these different substances varied. The tiles and brick were impressed with a stamp when in a soft state; the shells and tablets of stone were etched or graven, the figures or charac-

ABCDEFGHIJKLMNOPQRSTUVWXYZ&
abcdefghijklmnopqrstuvwxyz

1 2 3 4 5 6 7 8 9 0

, . : ; ! ? (|) * ' - — . . . fi fl ff ffi ffl fb @ £ \$ []

1/8 1/4 3/8 1/2 5/8 3/4 7/8

True set table characters. Figures and en quad .084; em quad .168; comma, period, and quotations .042. These sizes will be sent unless otherwise ordered.

Alignment. This face aligns with all 12-point one- and two-letter faces except German.

Will run in machines Nos. 2, 3, 4 and 5.

To avoid errors read notice on page six

MERGENTHALER LINOTYPE CO.

12-POINT BASKERVILLE CONDENSED

[ONE-LETTER]

Lower case alphabet 14.12 ems

The most ancient materials employed for recording events were bricks, tiles, shells and tables of stone. The modes of writing on these different substances were various. The tiles and brick were impressed with a stamp when in a soft state; the shells and tablets of stone were etched or graven, the figures or characters being cut in their surface, and in some

The most ancient materials used for recording events were shells, tiles, bricks, and tables of stone. The modes of writing on these different substances were various. The tiles and the brick were impressed with stamps when in a soft state; the shells and tablets were

ABCDEFGHIJKLMNOPQRSTUVWXYZ

abcdefghijklmnopqrstuvwxyz

1 2 3 4 5 6 7 8 9 0

. . . ; ! ? (|) * ' ' - — . . . fi fl ff ffi ffl lb @ £ \$ []

$\frac{1}{8}$ $\frac{1}{4}$ $\frac{3}{8}$ $\frac{1}{2}$ $\frac{5}{8}$ $\frac{3}{4}$ $\frac{7}{8}$

Special set table characters. Figures and figure space .091; double figure space .182; comma, period, and quotations .0455. These sizes will be sent unless otherwise ordered.

Alignment. This face aligns with all 12-point one- and two-letter faces except German.

Will run in machines Nos. 2, 3, 4 and 5.

To avoid errors read notice on page six

MERGENTHALER LINOTYPE CO.

14-POINT BASKERVILLE CONDENSED
[ONE-LETTER]

Lower case alphabet 12.87 ems

The most ancient materials used for recording events were bricks, tiles, shells, and tables of stone. The modes of writing on these different substances were various. The tiles and brick were impressed with a stamp when in a soft state; the shells and tablets of stone were etched or

The most ancient materials used to record events were tables of stone, bricks, tiles, and shells. The modes of writing on these different articles were varied. The tiles and brick were impressed with a stamp

ABCDEFGHIJKLMNOPQRSTUVWXYZ

abcdefghijklmnopqrstuvwxyz

1 2 3 4 5 6 7 8 9 0

, . : ; ! ? (|) * ' - — . . . fi fl ff ffi ffl lb @ £ \$ []

$\frac{1}{8}$ $\frac{1}{4}$ $\frac{3}{8}$ $\frac{1}{2}$ $\frac{5}{8}$ $\frac{3}{4}$ $\frac{7}{8}$

True set table characters. Figures and en quad .0968; em quad .1936; comma, period, and quotations .0484. Unit system, 1/2-point basis.

These sizes will be sent unless otherwise ordered.

Alignment. This face aligns with all 14-point one- and two-letter faces except German.

Will run in machines Nos. 2, 3, 4 and 5.

To avoid errors read notice on page six

SPECIMENS OF LINOTYPE FACES

14-POINT
BASKERVILLE
CONDENSED
One-Letter

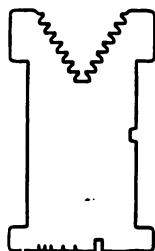

SPECIAL
CHARACTERS

Æ æ Œ œ § || ¶ † ‡ - /

1/3 2/3 1/5 2/5 3/5 4/5 1/6 5/6

MERGENTHALER LINOTYPE CO.

8-POINT CHELTENHAM BOLD FACE

[ONE-LETTER]

Lower case alphabet 14.58 ems

The most ancient materials employed for recording events were bricks, tiles, shells, and tables of stone. The modes of writing on these different substances were various. The tiles and brick were impressed with a stamp when in a soft state; the shells and tablets of stone were etched or graven, the figures or characters being cut in their surface, and in some cases also stained with various colors. It was by the ancient art of stamping that the walls, palaces, and towers of Babylon were covered with hieroglyphics, which have but recently been brought to light from under the immense Mounds of Mesopotamia, by Layard and other explorers. The patriarch Job, who is supposed to have lived about

The most ancient materials used for recording events were bricks, tiles, shells, and tables of stone. The modes of writing on these different substances were various. The tiles and brick were impressed with a stamp when in a soft state; the shells and tablets of stone were etched or graven, the figures or characters being cut in their surface, and in some cases also stained with various colors. It was by the ancient art of stamping that the walls, palaces, and towers of Babylon were covered with hieroglyphics, which have but recently been brought to light from under the immense mounds of Mesopotamia by Layard and other explorers. The patriarch Job, who is

ABCDEFGHIJKLMNOPQRSTUVWXYZ&

abcdefghijklmnopqrstuvwxyz

1 2 3 4 5 6 7 8 9 0

, . : ; ! ? (|) * ' ' - — . . . fi ff ffi @ lb £ \$ []

¼ ½ ¾ ⅓ ⅔ ⅖ ⅙

Special set table characters. Figures and figure space .0692; double figure space .1383; comma, period, and quotations .0345. Unit system, ¼-point basis. These sizes will be sent unless otherwise ordered.

Alignment. This face aligns with all 8-point one- and two-letter faces having low alignment except German.

Will run in all machines.

To avoid errors read notice on page six

MERGENTHALER LINOTYPE CO.

10-POINT CHELTENHAM BOLD FACE
[ONE-LETTER]

Lower case alphabet 14.62 ems

The most ancient materials employed for recording events were bricks, tiles, shells, and tables of stone. The modes of writing on these different substances were various. The tiles and brick were impressed with a stamp when in a soft state; the shells and tablets of stone were etched or graven, the figures or characters being cut in their surface, and in some cases stained with various colors. It was by the ancient art of stamping that the walls, palaces, and towers of Babylon were covered with hieroglyphics,

The most ancient materials used to record events were bricks, tiles, shells, and tables of stone. The modes of writing on these different substances were various. The tiles and brick were impressed with a stamp when in a soft state; the shells and tablets of stone were etched or graven, the figures or characters being cut in their surface, and in some cases also stained with various colors. It was by

ABCDEFGHIJKLMN OPQRSTUVWXYZ &
abcdefghijklmnopqrstu vwxyz

1 2 3 4 5 6 7 8 9 0

, . : ; ! ? (|) * ' ' - _ . . . fi ff ffi ffl lb @ £ \$ []
1/8 1/4 3/8 1/2 5/8 3/4 7/8

Special set table characters. Figures and figure space .083; double figure space .166; comma, period, and quotations .0415. Unit system, 1/4-point basis. These sizes will be sent unless otherwise ordered.

Alignment. This face aligns with all 10-point one- and two-letter faces except German.

Will run in all machines.

To avoid errors read notice on page six

MERGENTHALER LINOTYPE CO.

12-POINT CHELTENHAM BOLD FACE
[ONE-LETTER]

Lower case alphabet 12.12 ems

The most ancient materials employed for recording events were bricks, tiles, shells, and tables of stone. The modes of writing on these different substances were various. The tiles and brick were impressed with a stamp when in a soft state; the shells and tablets of stone were etched or graven, the figures or characters being cut in their surface, and in some cases also stained with various colors. It was by the ancient art of stamping that the

The most ancient materials used for recording events were bricks, tiles, shells, and tables of stone. The modes of writing on these different substances were various. The tiles and the brick were impressed with a stamp when in a soft state; the shells and tablets of stone were etched or graven, the figures or char-

ABCDEFGHIJKLMNOPQRSTUVWXYZ&

abcdefghijklmnopqrstuvwxyz

1 2 3 4 5 6 7 8 9 0

, . : ; ! ? (|) * ' ' - — . . . fi ff ffi ffl lb @ £ \$ []

1/8 1/4 3/8 1/2 5/8 3/4 7/8

Special set table characters. Figures and figure space .091; double figure space .182; comma, period, and quotations .0455. These sizes will be sent unless otherwise ordered.

Alignment. This face aligns with all 12-point one- and two-letter faces except German.

Will run in machines Nos. 2, 3, 4 and 5.

To avoid errors read notice on page six

SPECIMENS OF LINOTYPE FACES

12-POINT
CHELTENHAM
BOLD FACE
One-Letter

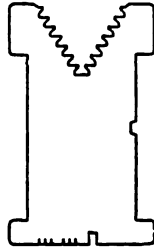

SPECIAL
CHARACTERS

Æ æ Œ œ

§ || ¶ † ‡ - /

1/3 2/3 1/5 2/5 3/5 4/5 1/6 5/6 1/8 1/4 3/8 1/2 5/8 3/4 7/8 1/3 2/3 1/5 2/5 1/8 5/8

Superior: 1 2 3 4 5 6 7 8 9 0

☼ ☺ ☾ ☽ ☾ ☽ ● ○ ⊕ ⊗ △ * ♀ ♀ † ♂
 ♂ ♂ Ω ℔ † ♁ ♁ ♂ ♂ ♂ ♂ ♂ ♂ ♂ ♂ ♂ ♂ ♂ ♂ ♂ ♂ ♂ ♂
 ≡ ℏ ℓ ℓ ℓ Δ □ ∠ ≡ ≡ √ < > ± ± ∴ ∴ ∴ ∴
 ☛ # ' " ° " « » ¶ * ¶ m/n % % % % % ☛
 ☛ 1 1 1 1 1 1 1 1 1 1 1 1 ☛

MERGENTHALER LINOTYPE CO.

8-POINT CELTIC NO. 1

[ONE-LETTER]

Lower case alphabet 19.25 ems

The most ancient materials used for recording events were bricks, tiles, shells, and tables of stone. The modes of writing on these different substances were various. The tiles and brick were impressed with a stamp when in a soft state; the shells and tablets of stone were etched or graven, the figures or characters being cut in their surface, and in some cases also stained with various colors. It was by the ancient art of stamping that the walls, palaces, and towers of Babylon were covered with hieroglyphics, which have but recently been brought to light from the immense mounds

The most ancient materials employed for recording events were bricks, tiles, shells, and tables of stone. The modes of writing on these different substances were various. The tiles and brick were impressed with a stamp when in a soft state; the shells and tablets of stone were etched or graven, the figures or characters being cut in their surface, and in some cases also stained with various colors. It was by the ancient art of stamping that

ABCDEFGHIJKLMN OPQRSTUVWXYZ&

abcdefghijklmnopqrstuvwxyz

1 2 3 4 5 6 7 8 9 0

, . : ; ? ! (|) * ' ' - - . . . fi fl ff ffi ffl lb @ £ \$ []

1/8 1/4 3/8 1/2 5/8 3/4 7/8

Special set table characters. Figures and figure space .084; comma, period, and quotations .042. These sizes will be sent unless otherwise ordered.

Alignment. This face aligns with all 8-point one- and two-letter faces having high alignment except German.

Will run in all machines.

To avoid errors read notice on page six

MERGENTHALER LINOTYPE CO.

12-POINT CASLON TEXT

[ONE-LETTER]

Lower case alphabet 13.57 ems

The most ancient materials employed for recording events were bricks, tiles, shells, and tables of stone. The modes of writing on these different substances were various. The tiles and brick were impressed with a stamp when in a soft state; the shells and tablets of stone were etched or graven, the figures or characters being cut in their surface, and in some cases also stained with various colors. It was by

The most ancient materials used for recording events were bricks, tiles, shells, and tables of stone. The modes of writing on these different substances were various. The tiles and the brick were impressed with a stamp when in a soft state; the shells and tablets of stone were etched or graven,

ABCDEFGHIJKLMN O P Q R S T U V W X
abcdefghijklmnopqrstuvwxyz
1 2 3 4 5 6 7 8 9 0
, . : ; ? ' (|) * ' ' — ... ſ ſ ſ ſ ſ ſ ſ ſ @ \$ £ []

True set table characters. Figures and en quad .084; em quad .168; comma, period, and quotations .042. These sizes will be sent unless otherwise ordered.

Alignment. This face aligns with all 12-point one- and two-letter faces except German.

Will run in machines Nos. 2, 3, 4 and 5.

To avoid errors read notice on page six

SPECIMENS OF LINOTYPE FACES

12-POINT
CASLON TEXT
One-Letter

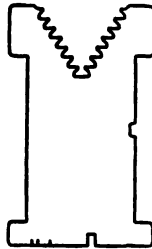

SPECIAL
CHARACTERS

ä ö ù ç ck fi ft h ll k ff

|| - - - - - - - - - - - ç /

+ + - × × ÷ =

1/3 2/3 1/6 5/6 3/8 4/8 1/8 5/8

Superior: 1 2 3 4 5 6 7 8 9 0

☼ ☺ ☾ ☽ ☾ ☽ ● ○ ⊕ ⊗ △ * ♀ ♀ † ‡
 ∞
 ∞
 ☛ # ' " ° " « » ☛ * ☛ m/n % % % % ☛
 ☛ 1 1 1 1 1 1 1 1 1 1 1 1 1 1 1 1 ☛

MERGENTHALER LINOTYPE CO.

5½-POINT BOLD FACE NO. 1

[ONE-LETTER]

Lower case alphabet 22.82 ems

The most ancient materials used for recording events were bricks, tiles, shells, and tables of stone. The modes of writing on these different substances were various. The tiles and brick were impressed with a stamp when in a soft state; the shells and tablets of stone were etched or graven, the figures or characters being cut in their surface, and in some cases also stained with various colors. It was by the ancient art of stamping that the walls, palaces, and towers of Babylon were covered with hieroglyphics, which have but recently been brought to light from under the immense mounds of Mesopotamia by Layard and other explorers. The patriarch Job, who is supposed to have lived about 2,300 years after the creation, exclaimed, "O that my words were now written! O that they were printed in a book! that they were graven with an iron pen, and hid in the

The most ancient materials employed for recording events were bricks, tiles, shells, and tables of stone. The modes of writing on these different substances were various. The tiles and brick were impressed with a stamp when in a soft state; the shells and tablets of stone were etched or graven, the figures or characters being cut in their surface, and in some cases also stained with various colors. It was by the ancient art of stamping that the walls, palaces, and towers of Babylon were covered with hieroglyphics, which have but recently been brought to light from under the immense mounds of Mesopotamia by Layard and other explorers. The patriarch Job, who is supposed to have lived about 2,300 years

ABCDEFGHIJKLMN OPQRSTUVWXYZ&

abcdefghijklmnopqrstuvwxyz

1 2 3 4 5 6 7 8 9 0

, . : ; ! ? () ' * - . . . ¢ ¤ ¥ £ ¤ @ £ ¤ []

½ ¼ ⅓ ¼ ⅕ ⅙ ⅚

Special set table characters. Figures and figure space .063; double figure space .126; comma, period and quotations .0315. These sizes will be sent unless otherwise ordered.

Alignment. This face aligns with all 5½-point one- and two-letter faces except German.

Will run in all machines.

To avoid errors read notice on page six

SPECIMENS OF LINOTYPE FACES

**5½-POINT
BOLD FACE NO. 1
One-Letter**

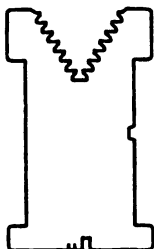

**SPECIAL
CHARACTERS**

High Cap Accents—These require a special mold.

À Á Â Ã Ä Å Æ Ç È É Ê Ë Ì Í Î Ï Ñ Ò Ó Ô Õ Ö Ù Ú Û Ü

Low Cap Accents—Regular mold may be used.

À Á Â Ã Ä Å Æ Ç È É Ê Ë Ì Í Î Ï Ñ Ò Ó Ô Õ Ö Ù Ú Û Ü

À Á Â Ã Ä Å Æ Ç È É Ê Ë Ì Í Î Ï Ñ Ò Ó Ô Õ Ö Ù Ú Û Ü

À Á Â Ã Ä Å Æ Ç È É Ê Ë Ì Í Î Ï Ñ Ò Ó Ô Õ Ö Ù Ú Û Ü

À Á Â Ã Ä Å Æ Ç È É Ê Ë Ì Í Î Ï Ñ Ò Ó Ô Õ Ö Ù Ú Û Ü

À Á Â Ã Ä Å Æ Ç È É Ê Ë Ì Í Î Ï Ñ Ò Ó Ô Õ Ö Ù Ú Û Ü

À Á Â Ã Ä Å Æ Ç È É Ê Ë Ì Í Î Ï Ñ Ò Ó Ô Õ Ö Ù Ú Û Ü

À Á Â Ã Ä Å Æ Ç È É Ê Ë Ì Í Î Ï Ñ Ò Ó Ô Õ Ö Ù Ú Û Ü

Superior Fractions: ¼ ½ ¾ ⅓ ⅔

À Á Â Ã Ä Å Æ Ç È É Ê Ë Ì Í Î Ï Ñ Ò Ó Ô Õ Ö Ù Ú Û Ü

À Á Â Ã Ä Å Æ Ç È É Ê Ë Ì Í Î Ï Ñ Ò Ó Ô Õ Ö Ù Ú Û Ü

À Á Â Ã Ä Å Æ Ç È É Ê Ë Ì Í Î Ï Ñ Ò Ó Ô Õ Ö Ù Ú Û Ü

MERGENTHALER LINOTYPE CO.

8-POINT BOLD FACE NO. 1 [ONE-LETTER]

Lower case alphabet 15.38 ems

The most ancient materials used for recording events were bricks, tiles, shells, and tables of stone. The modes of writing on these different substances were various. The tiles and brick were impressed with a stamp when in a soft state; the shells and tables of stone were etched or graven, the figures or characters being cut in their surface, and in some cases also stained with various colors. It was by the ancient art of stamping that the walls, palaces, and towers of Babylon were covered with hieroglyphics, which have but recently been brought to light from under the immense mounds of Mesopotamia by Layard and other explorers. The patriarch Job, who is supposed to have lived about

The most ancient materials used for recording events were bricks, tiles, shells, and tables of stone. The modes of writing on these different substances were various. The tiles and brick were impressed with a stamp when in a soft state; the shells and tablets of stone were etched or graven, the figures or characters being cut in their surface, and in some cases also stained with various colors. It was by the ancient art of stamping that the walls, palaces, and towers of Babylon were covered with hieroglyphics, which have but recently been brought to light from under the immense mounds of Meso-

ABCDEFGHIJKLMNOPQRSTUVWXYZ&

abcdefghijklmnopqrstuvwxyz

1 2 3 4 5 6 7 8 9 0

, . : ; ! ? (|) * ' - _ . . . ñ ñ ñ ñ ñ ñ ñ @ £ \$ []

¼ ½ ¾

Special set table characters. Figures and figure space .083; double figure space .166; comma, period, and quotations .0415. Unit system ¼-point basis. These sizes will be sent unless otherwise ordered.

Alignment. This face aligns with all 8-point one- and two-letter faces having low alignment except German.

Will run in all machines.

To avoid errors read notice on page six

MERGENTHALER LINOTYPE CO.

10-POINT BOLD FACE NO. 1
[ONE-LETTER]

Lower case alphabet 16.61 ems

The most ancient materials employed for recording events were bricks, tiles, shells, and tables of stone. The modes of writing on these different substances were various. The tiles and brick were impressed with a stamp when in a soft state; the shells and tables of stone were etched or graven, the figures or characters being cut in their surface, and in some cases also stained with various colors. It was by the ancient art of stamping that the walls, pala-

The most ancient materials used for recording events were bricks, tiles, shells, and tables of stone. The modes of writing on these different substances were various. The tiles and the brick were impressed with a stamp when in a soft state; the shells and tablets of stone were etched or graven, the figures or char-

ABCDEFGHIJKLMN OPQRSTUVWXYZ
abcdefghijklmnopqrstu vwxyz

1 2 3 4 5 6 7 8 9 0

, . : ; ! ? (|) * ' ' - - . . . fi fi ff ffi ffi lb @ £ \$ []

1/8 1/4 3/8 1/2 5/8 3/4 7/8

Special set table characters. Figures and figure space .091; comma, period, and quotations .0455. These sizes will be sent unless otherwise ordered.

Alignment. This face aligns with all 10-point one- and two-letter faces except German.

Will run in machines Nos. 2, 3, 4 and 5.

To avoid errors read notice on page six

MERGENTHALER LINOTYPE CO.

12-POINT BOLD FACE NO. 1
[ONE-LETTER]

Lower case alphabet 18.42 ems

The most ancient materials employed for recording events were bricks, tiles, shells, and tables of stone. The modes of writing on these different substances were various. The tiles and bricks were impressed with a stamp when in a soft state; the shells and tablets of stone were etched or graven, the figures or char-

The materials used for recording events were bricks, shells, and tables of stone. The modes of writing upon these different substances were various. The shells and tablets of stone were etched or graven, the

ABCDEFGHIJKLMN O P Q R S T U V W X

abcdefghijklmnopqrstuvwxy z

1 2 3 4 5 6 7 8 9 0

, . : ; ! ? * ' - _ ... fi fl ff m ll lb @ £ \$ []

$\frac{1}{8}$ $\frac{1}{4}$ $\frac{3}{8}$ $\frac{1}{2}$ $\frac{5}{8}$ $\frac{3}{4}$ $\frac{7}{8}$

Special set table characters. Figures and figure space .112; comma, period, and quotations .056. These sizes will be sent unless otherwise ordered.

Alignment. This face aligns with all 12-point one- and two-letter faces except German.

Will run in machines Nos. 2, 3, 4 and 5.

To avoid errors read notice on page six

MERGENTHALER LINOTYPE CO.

7-POINT BOLD FACE ITALIC NO. 1

[TWO-LETTER]

Lower case alphabet 17.65 ems

The most ancient materials used for recording events were bricks, tiles, shells, and tables of stone. The modes of writing on these different substances were various. The tiles and brick were impressed when in a soft state; the shells and tablets of stone were etched or graven, the figures or characters being cut in their surface, and in some cases also stained with various colors. It was by the ancient art of stamping that the walls, palaces, and towers of Babylon were covered with hieroglyphics, which have but recently been brought to light by Layard and other explorers. The patriarch Job, who is supposed to have lived about 2,300 years after the creation, exclaimed, "O that my words were now written! O that they were graven with an iron pen, and hid in the rock forever!" Stung by the unjust accusation of his friends, he desires to record his words that the generations fol-

The most ancient materials employed for recording events were bricks, tiles, shells, and tables of stone. The modes of writing on these different substances were various. The tiles and brick were impressed with a stamp when in a soft state; the tablets of stone and shells were etched or graven, the figures or characters being cut in their surface, and in some cases also stained with various colors. It was by the ancient art of stamping that the towers, palaces, and walls of Babylon were covered with hieroglyphics, which have but recently been brought to light from under the immense mounds of Mesopotamia by Layard and other ex-

ABCDEFGHIJKLMNOPQRSTUVWXYZ&

abcdefghijklmnopqrstuvwxyz

1 2 3 4 5 6 7 8 9 0

, . : ; ! ? (|) * ' - — . . . ß ß ß ß ß ß ß @ £ \$ []

Special set table characters. Figures and figure space .077; double figure space .154; comma, period, and quotations .0385. These sizes will be sent unless otherwise ordered.

Alignment. This face aligns with all 7-point one- and two-letter faces except German.

Will run in all machines.

To avoid errors read notice on page six

MERGENTHALER LINOTYPE CO.

7-POINT DORIC NO. 1

[ONE-LETTER]

Lower case alphabet 13.44 ems

The most ancient materials used for recording events were bricks, tiles, shells, and tables of stone. The modes of writing on these different substances were various. The tiles and brick were impressed with a stamp when in a soft state; the shells and tablets of stone were etched or graven, the figures or characters being out in their surface, and in some cases also stained with various colors. It was by the ancient art of stamping that the walls, palaces, and towers of Babylon were covered with hieroglyphics, which have but recently been brought to light from under the immense mounds of Mesopotamia by Layard and other explorers. The patriarch Job, who is supposed to

The most ancient materials used for recording events were bricks, tiles, shells, and tables of stone. The modes of writing on these different substances were various. The tiles and brick were impressed with a stamp when in a soft state; the shells and tablets of stone were etched or graven, the figures or characters being out in their surface, and in some cases also stained with various colors. It was by the ancient art of stamping that the walls, palaces, and towers of Babylon were covered with hieroglyphics, which have but recently been brought to light from under the immense mounds of Mesopo-

ABCDEFGHIJKLMN OPQRSTUVWXYZ&

abedefghijklmnopqrstuvwxyz

1 2 3 4 5 6 7 8 9 0

, . : ; ! ? (|) * ' ' . . . - - ¢ ¢ ¢ ¢ ¢ @ £ \$ []

½ ¼ ⅓ ⅒ ⅑ ⅘

Special set table characters. Figures and figure space .077; double figure space .154; comma, period, and quotations .031. These sizes will be sent unless otherwise ordered.

Alignment. This face aligns with all 7-point one- and two-letter faces except German.

Will run in all machines.

To avoid errors read notice on page six

MERGENTHALER LINOTYPE CO.

10-POINT DORIC NO. 1
[ONE-LETTER]

Lower case alphabet 16.84 ems

The most ancient materials employed for recording events were bricks, tiles, shells, and tables of stone. The modes of writing on these substances were various. The tiles and brick were impressed with a stamp when in a soft state; the shells and tablets of stone were etched or graven, figures or characters being cut in their surface, and in some cases also stained with various colors. The patriarch Job,

The most ancient materials employed for recording events were bricks, shells, tiles, and tables of stone. The modes of writing on these different substances were various. The tiles and brick were impressed with a stamp when in a soft state; the shells and tablets of stone were etched or graven, the figures or charac-

ABCDEFGHIJKLMNOPQRSTUVWXYZ&

abcdefghijklmnopqrstuvwxy

1 2 3 4 5 6 7 8 9 0

, . : ; ! ? (|) * ' ' - - . . . ¢ ¢ ¢ ¢ ¢ ¢ ¢ ¢ ¢ @ £ \$ []

1/8 1/4 3/8 1/2 5/8 3/4 7/8

Special set table characters. Figures and figure space .091; comma, period, and quotations .0455. These sizes will be sent unless otherwise ordered.

Alignment. This face aligns with all 10-point one- and two-letter faces except German.

Will run in machines Nos. 2, 3, 4 and 5.

To avoid errors read notice on page six

MERGENTHALER LINOTYPE CO.

11-POINT DORIC NO. 2

[ONE-LETTER]

Lower case alphabet 12.65 ems

The most ancient materials used for recording events were bricks, tiles, shells, and tables of stone. The modes of writing on these different substances varied. The tiles and brick were impressed with a stamp when in a soft state; the tablets of stone and shells were etched or graven, the figures or characters being cut in their surface, and

The most ancient materials employed for recording events were bricks, tiles, shells, and tables of stone. The modes of writing upon these substances were various. The tiles and brick were impressed with a stamp when in a soft state; the shells and tablets of stone

ABCDEFGHIJKLMNOPQRSTUVWXYZ

abcdefghijklmnopqrstuvwxyz

1 2 3 4 5 6 7 8 9 0

, . : ; ! ? (!) * ' - — . . . fi fi fi fi fi lb @ £ \$ []

1/8 1/4 3/8 1/2 5/8 3/4 7/8

Special set table characters. Figures and figure space .098; comma, period and quotations .049. These sizes will be sent unless otherwise ordered.

Alignment. This face aligns with all 11-point one- and two-letter faces except German.

Will run in machines Nos. 2, 3, 4 and 5.

To avoid errors read notice on page six

MERGENTHALER LINOTYPE CO.

9-POINT BOLD FACE NO. 1

[ONE-LETTER]

Lower case alphabet 12.80 ems

So wenig für mein treues Volk als für Deutsche bedarf es einer Rechenschaft über die Ursachen des Krieges, welcher jetzt beginnt: Klar liegen sie dem unverbundenen Europa vor Augen. Wir erlagen unter der Uebermacht Frankreichs. Der Friede, der die Hälfte meiner Unterthanen mir entriß, gab uns seine Segnungen nicht, denn er schlug uns tiefere Wunden, als selbst der Krieg. Das Mark des Landes ward ausgefogen. Die Hauptfestungen blieben vom Feinde besetzt, der Ackerbau ward gelähmt, sowie der sonst so hochgebrachte Kunstfleiß unserer Städte. Die Freiheit des Handels ward gehemmt,

So wenig für mein treues Volk als für Deutsche bedarf es einer Rechenschaft über die Ursachen des Krieges, welcher jetzt beginnt: Klar liegen sie dem unverbundenen Europa vor Augen. Wir erlagen unter der Uebermacht Frankreichs. Der Friede, der die Hälfte meiner Unterthanen mir entriß, gab uns seine Segnungen nicht, denn er schlug uns tiefere Wunden als selbst der Krieg. Das Mark des Landes ward ausgefogen. Die Hauptfestungen blieben vom

A B C D E F G H I J K L M N O P Q R S T U V W X Y Z &

a b c d e f g h i j k l m n o p q r s t u v w x y z

1 2 3 4 5 6 7 8 9 0

, . : ; ! ? () „ “ * ’ - ñ ñ ñ ñ ñ \$ []

ä ö ü

fi ft fz ff k ll ch d

1/8 1/4 3/8 1/2 5/8 3/4 7/8

Special set table characters. Figures and figure space .084; comma and period, .042. These sizes will be sent unless otherwise ordered.

Alignment. This face aligns with all 9-point German one- and two-letter faces.

Will run in all machines.

To avoid errors read notice on page six

MERGENTHALER LINOTYPE CO.

6-POINT BOLD FACE NO. 2
[ONE-LETTER]

Lower case alphabet 14.83 ems

So wenig für mein treues Volk als für Deutsche bedarf es einer Rechenschaft über die Ursachen des Kriegs, welcher jetzt beginnt: Klar liegen sie dem unverbündeten Europa vor Augen. Wir erlagen unter der Uebermacht Frankreichs. Der Friede, der die Hälfte meiner Unterthanen mir entriß, gab uns keine Segnungen nicht, denn er schlug uns tiefere Wunden als selbst der Krieg. Das Mark des Landes ward ausgezogen. Die Hauptfestungen blieben vom Feinde besetzt, der Ackerbau ward gelähmt, sowie der sonst so hochgebrachte Kunstfleiß unserer Städte. Der Freiheit des Handels ward gehemmt, und dadurch die Quelle des Erwerbes und des Wohlstandes verstopft. Das Land ward ein Raub der Verarmung. Durch die strengste Erfüllung eingegangener Verbindlichkeiten hoffte ich meinem Volke Erleichterung zu verschaffen, und den französischen Kaiser endlich zu überzeugen, daß es sein eigener Vortheil sei Preußen seine Unabhängigkeit zu lassen. Aber meine reinsten Absichten wurden durch Uebermuth und Treulosigkeit vereitelt, und nur zu deutlich sahen wir, daß des Kaisers Verträge mehr noch wie seine Kriege, uns langsam verderben mußten

So wenig für mein treues Volk als für Deutsche bedarf es einer Rechenschaft über die Ursachen des Kriegs, welcher jetzt beginnt: Klar liegen sie dem unverbündeten Europa vor Augen. Wir erlagen unter der Uebermacht Frankreichs. Der Friede, der die Hälfte meiner Unterthanen mir entriß, gab uns keine Segnungen nicht, denn er schlug uns tiefere Wunden als selbst der Krieg. Das Mark des Landes ward ausgezogen. Die Hauptfestungen blieben vom Feinde besetzt, der Ackerbau ward gelähmt, sowie der sonst so hochgebrachte Kunstfleiß unserer Städte. Die Freiheit des Handels ward gehemmt, und dadurch die Quelle des Erwerbes und des Wohlstandes verstopft. Das Land ward ein Raub der Verarmung. Durch die strengste Erfüllung eingegangener Verbindlichkeiten hoffte ich meinem Volke Erleichterung zu verschaffen, und den französischen Kaiser endlich zu überzeugen, daß es sein eigener Vortheil sei, Preußen seine Unabhängig-

ABCDEFGHIJKLMN O PQRSTU VWXYZ

abcdefghijklmnopqrstuvwxyz

1 2 3 4 5 6 7 8 9 0

, . : ; ! ? () " ' * - # \$ % []

¼ ½ ¾ ⅓ ⅔ ⅖ ⅙

ä ö ü

ſ ſ ſ ſ ſ ſ ſ ſ

Special set table characters. Figures and figure space .052; double figure space .104; comma and period .028. These sizes will be sent unless otherwise ordered.

Alignment. This face aligns with all 6-point German one- and two-letter faces.

Will run in all machines.

To avoid errors read notice on page six

MERGENTHALER LINOTYPE CO.

10-POINT BOLD FACE NO. 2
[ONE-LETTER]

Lower case alphabet 11.75 ems

So wenig für mein treues Volk als für Deutsche bedarf es einer Rechenschaft über die Ursachen des Kriegs, welcher jetzt beginnt: klar liegen sie dem unverblendeten Europa vor Augen. Wir erlagen unter der Uebermacht Frankreichs. Der Friede, der die Hälfte meiner Unterthanen mir entriß, gab uns seine Segnungen nicht, denn er schlug uns tiefere Wunden, als selbst der Krieg. Das Mark des Landes ward ausgefogen. Die Hauptfestungen blieben vom Feinde besetzt, der Ackerbau ward gelähmt, sowie der sonst so hochgebrachte Kunstfleiß unserer Städte. Die

So wenig für mein treues Volk als für Deutsche bedarf es einer Rechenschaft über die Ursachen des Kriegs, welcher jetzt beginnt: klar liegen sie dem unverblendeten Europa vor Augen. Wir erlagen unter der Uebermacht Frankreichs. Der Friede, der die Hälfte meiner Unterthanen mir entriß, gab uns seine Segnungen nicht, denn er schlug uns tiefere Wunden als selbst der Krieg. Das Mark des Landes ward ausgefogen. Die

A B C D E F G H I J K L M N O P Q R S T U V W X Y Z &

a b c d e f g h i j k l m n o p q r s t u v w x y z

1 2 3 4 5 6 7 8 9 0

, . : ; ! ? () " * ' - — ñ ſ ſ ſ ſ \$ []

ä ö ü

ſ ſ ſ ſ ſ ſ ſ ſ ſ ſ

Special set table characters. Figures and figure space .074, double figure space .148; comma and period .037. These sizes will be sent unless otherwise ordered.

Alignment. This face aligns with all 10-point German one- and two-letter faces.

Will run in all machines.

To avoid errors read notice on page six

MERGENTHALER LINOTYPE CO.

11-POINT BOLD FACE NO. 2

[ONE-LETTER]

Lower case alphabet 11.90 ems

So wenig für mein treues Volk als für Deutsche bedarf es einer Rechenschaft über die Ursachen des Kriegs, welcher jetzt beginnt: klar liegen sie dem unverblendeten Europa vor Augen. Wir erlagen unter der Uebermacht Frankreichs. Der Friede, der die Hälfte meiner Unterthanen mir entriß, gab uns seine Segnungen nicht, denn er schlug uns tiefere Wunden, als selbst der Krieg. Das Mark des Landes ward ausgezogen. Die Hauptfestungen blieben vom Feinde besetzt, der Ackerbau ward ge-

So wenig für mein treues Volk als für Deutsche bedarf es einer Rechenschaft über die Ursachen des Kriegs, welcher jetzt beginnt: klar liegen sie dem unverblendeten Europa vor Augen. Wir erlagen unter der Uebermacht Frankreichs. Der Friede, der die Hälfte meiner Unterthanen mir entriß, gab uns seine Segnungen nicht, denn er schlug uns tiefere Wunden als selbst der Krieg. Das

ABCDEFGHIJKLMN O PQRSTU VWXYZ&

abcdefghijklmnopqrstu vwxyz

1 2 3 4 5 6 7 8 9 0

, . : ; ! ? () „ “ * ’ = — fi fl ff lb \$ []

ä ö ü

fi fl ff lb \$ []

Special set table characters. Figures and figure space .0815; double figure space .163; comma, period, and quotations .04075. These sizes will be sent unless otherwise ordered.

Alignment. This face aligns with all 11-point German one- and two-letter faces.

Will run in all machines.

To avoid errors read notice on page six



***Two-Letter
Job Faces***

MERGENTHALER LINOTYPE CO.

5½-POINT BOLD FACE NO. 1 WITH BOLD FACE ITALIC

[TWO-LETTER]

Lower case alphabet 21.58 ems

The most ancient materials employed for recording events were bricks, tiles, shells, and tables of stone. The modes of writing on these different substances were various. The tiles and brick were impressed with a stamp when in a soft state; the shells and tablets of stone were etched or graven, the figures or characters being cut in their surface, and in some cases also stained with various colors. It

The most ancient materials employed for recording events were bricks, tiles, shells, and tables of stone. The modes of writing on these different substances were various. The tiles and brick were impressed with a stamp when in a soft state; the shells and tablets of stone were etched or graven, the figures or characters being cut in their surface, and in some cases also stained with various colors. It

The most ancient materials employed for recording events were brick, tile, shells, and slabs of stone. The modes of writing on these different substances were many. The tile and brick were impressed with a stamp when in a soft state; the shells and tables of stone were etched or graven, the figures or characters being cut in

The most ancient materials employed for recording events were brick, tile, shells, and slabs of stone. The modes of writing on these different substances were many. The tile and brick were impressed with a stamp when in a soft state; the shells and tables of stone were etched or graven, the figures or characters being cut in their surface, and in some cases also stained with various colors. It was

ABCDEFGHIJKLMNOPQRSTUVWXYZ&

ABCDEFGHIJKLMNOPQRSTUVWXYZ&

abcdefghijklmnopqrstuvwxyx

abcdefghijklmnopqrstuvwxyx

1 2 3 4 5 6 7 8 9 0

1 2 3 4 5 6 7 8 9 0

, . : ; ! ? (|) ' ' * - — . . . n n n m m n \$ %
 , . : ; ! ? (|) ' ' * - — . . . n n n n n n n \$ %

One-Letter Matrices.

@ [] ¼ ½ ¾ % ½ % % %

Special set table characters. Figures and figure space .063; double figure space .126; comma, period, and quotations .0315. These sizes will be sent unless otherwise ordered.

Alignment. This face aligns with all 5½-point one- and two-letter faces except German.

Will run in all machines.

To avoid errors read notice on page six

MERGENTHALER LINOTYPE CO.

7-POINT BOLD FACE NO. 1 WITH BOLD FACE ITALIC [TWO-LETTER]

Lower case alphabet 17.50 ems

The most ancient materials used for recording events were bricks, tiles, shells, and tables of stone. The modes of writing on these different substances were various. The tiles and brick were impressed with a stamp when in a soft state; the shells and tablets of stone were etched or graven, the figures or characters

The most ancient materials used for recording events were bricks, tiles, shells, and tables of stone. The modes of writing on these different substances were various. The tiles and brick were impressed with a stamp when in a soft state; the shells and tablets of stone were etched or graven, the figures or characters

The most ancient materials used to record events were bricks, tiles, and tablets of stone. The modes of writing on these different substances were various. The tiles and brick were impressed with a stamp when in a soft state; the shells and tab-

The most ancient materials used to record events were bricks, tiles, and tablets of stone. The modes of writing on these different substances were various. The tiles and brick were impressed with a stamp when in a soft state; the shells and tab-

**ABCDEFGHIJKLMN OPQRSTUVWXYZ&
ABCDEFGHIJKLMN OPQRSTUVWXYZ&**

**abcdefghijklmnopqrstuvwxy
abcdefghijklmnopqrstuvwxy**

**1 2 3 4 5 6 7 8 9 0
1 2 3 4 5 6 7 8 9 0**

, . : ; ! ? (|) ' ' - — ß ß ß ß ß ß ß £ \$
, . : ; ! ? (|) ' ' - — ß ß ß ß ß ß ß £ \$
@ * ¼ ½ ¾ []

Special set table characters. Figures and figure space .077; double figure space .154; comma, period, and quotations .0385. These sizes will be sent unless otherwise ordered.

Alignment. This face aligns with all 7-point one- and two-letter faces except German.

Will run in all machines.

To avoid errors read notice on page six

MERGENTHALER LINOTYPE CO.

5½-POINT BOLD FACE NO. 1 WITH 8-POINT IONIC NO. 1 [TWO-LETTER]

Lower case alphabet 22.75 5¼-point and 15.64 8-point ems

The most ancient materials employed for recording events were bricks, tiles, shells, and tables of stone. The modes of writing on these different substances were various. The tiles and brick were impressed with a stamp when in a soft state; the shells and tablets of stone were etched or graven, the figures or characters

The most ancient materials employed for recording events were bricks, tiles, shells, and tables of stone. The modes of writing on these different substances were various. The tiles and brick were impressed with

The most ancient materials used for recording events were bricks, tiles, shells, and stone. The modes of writing on these substances were various. The tiles and brick were impressed with a stamp when in a soft state; the shells and tablets of

The most ancient materials used for recording events were bricks, tiles, shells, and stone. The modes of writing on these substances were various. The tiles and brick were impressed with a stamp when in a soft state; the shells and tablets of

ABCDEFGHIJKLMN OPQRSTUVWXYZ&

ABCDEFGHIJKLMN OPQRSTUVWXYZ&

abcdefghijklmnopqrstuvwxy

abcdefghijklmnopqrstuvwxy

1 2 3 4 5 6 7 8 9 0

1 2 3 4 5 6 7 8 9 0

, . ; ! ? (|) ' * - - . . . a n n m m b \$ £

, . ; ! ? (|) ' * - - . . . a n n m m b \$ £

@ [] ½ ¼ ⅓ ½ ⅔ ¾

@ [] ½ ¼ ⅓ ½ ⅔ ¾

Special set table characters. Figures and figure space .070; double figure space .140; comma, period, and quotations .035. These sizes will be sent unless otherwise ordered.

Alignment. 5½-point Bold Face No. 1 aligns with all 5½-point one- and two-letter faces except German. 8-point Ionic aligns with all 8-point one- and two-letter faces having high alignment.

Will run in all machines.

To avoid errors read notice on page six

SPECIMENS OF LINOTYPE FACES

**5½-POINT
BOLD FACE NO. 1
WITH
8-POINT
IONIC NO. 1
Two-Letter**

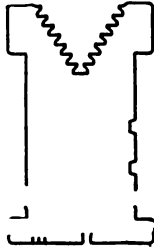

**SPECIAL
CHARACTERS**

Low Cap Accents—Regular mold may be used.

A Æ I Ñ O U U
 A Æ I Ñ O U U
 a æ i ñ o u u
 â é î ñ ô ú û
 Æ æ Œ œ
 Æ æ Œ œ
 ¼ ½ ¾ ¼ ¾ ¼ ¾ ¼
 ⅓ ⅔ ⅓ ⅔ ⅓ ⅔ ⅓ ⅔
 % i j -
 % i d -

One-letter Matrices to be used for two-letter work

% Æ ð 3 5 " "

MERGENTHALER LINOTYPE CO.

8-POINT TITLE NO. 2 WITH TITLE ITALIC
[TWO-LETTER]

Lower case alphabet 15.71 ems

The most ancient materials employed for recording events were bricks, tiles, shells, and tables of stone. The modes of writing on these different substances were various. The tiles and brick were impressed with a stamp when in a soft state; the shells and tablets of

The most ancient materials employed for recording events were bricks, tiles, shells, and tables of stone. The modes of writing on these different substances were various. The tiles and brick were impressed with a stamp when in a soft state; the shells and tablets of

The most ancient materials used to record events were bricks, tiles, and tablets of stone. The modes of writing on these substances were various. The tiles and brick were impressed with a stamp when in a soft state; the shells and tablets of

The most ancient materials used to record events were bricks, tiles, and tablets of stone. The modes of writing on these substances were various. The tiles and brick were impressed with a stamp when in a soft state; the shells and tablets of

ABCDEFGHIJKLMNOPQRSTUVWXYZ&
ABCDEFGHIJKLMNOPQRSTUVWXYZ&

abcdefghijklmnopqrstuvwxy
abcdefghijklmnopqrstuvwxy

1 2 3 4 5 6 7 8 9 0
1 2 3 4 5 6 7 8 9 0

, . : ; ! ? (|) ‘ ’ - — . . . ñ ñ ñ ñ ñ ñ ð £ \$
, . : ; ! ? (|) ‘ ’ - — . . . ñ ñ ñ ñ ñ ñ ð £ \$
@ * 1/8 1/4 3/8 1/2 5/8 3/4 7/8 []

Special set table characters. Figures and figure space .070; double figure space .140; comma, period, and quotations .035. These sizes will be sent unless otherwise ordered.

Substitute table characters for use with this face can be had as follows: 8-point Title No. 2 two-letter Modernized figures.—Figures and figure space .070; double figure space .140.

Alignment. This face aligns with all 8-point one- and two-letter faces having low alignment except German.

Will run in all machines.

To avoid errors read notice on page six

MERGENTHALER LINOTYPE CO.

10-POINT TITLE NO. 2 WITH TITLE ITALIC
[TWO-LETTER]

Lower case alphabet 14.2 ems

The most ancient materials used for recording events were bricks, tiles, shells, and tables of stone. The modes of writing on these different substances were various. The tiles and brick

The most ancient materials used for recording events were bricks, tiles, shells, and tables of stone. The modes of writing on these different substances were various. The tiles and brick

The most ancient materials employed in recording events were bricks, tiles, shells, and tables of stone. The modes of writing on these different substances varied. The tiles and brick were

The most ancient materials employed in recording events were bricks, tiles, shells, and tables of stone. The modes of writing on these different substances varied. The tiles and brick were

ABCDEFGHIJKLMN OPQRSTUVWXYZ &
ABCDEFGHIJKLMN OPQRSTUVWXYZ &

abcdefghijklmnopqrstuvwxy z
abcdefghijklmnopqrstuvwxy z

1 2 3 4 5 6 7 8 9 0

1 2 3 4 5 6 7 8 9 0

, . : ; ! ? () * ' - — . . . ñ ñ ñ ñ ñ ñ ñ ñ £ \$
, . : ; ! ? () ' ' - — . . . ñ ñ ñ ñ ñ ñ ñ ñ £ \$

One-Letter Matrices

@ [] 1/8 1/4 3/8 1/2 5/8 3/4 7/8

True set table characters. Figures and en quad .070; em quad .140; comma, period, and quotations .035. These sizes will be sent unless otherwise ordered.

Alignment. This face aligns with all 10-point one- and two-letter faces except German.

Will run in all machines.

To avoid errors read notice on page six

MERGENTHALER LINOTYPE CO.

5½-POINT BOLD FACE NO. 1 WITH 10-POINT CLARENDON NO. 1 [TWO-LETTER]

Lower case alphabet 22.86 5½-point and 12.57 10-point ems

The most ancient materials used for recording events were bricks, tiles, shells, and tables of stone. The modes of writing on these different substances were various. The tiles and brick were impressed with a stamp when in a soft state; the shells and tablets of

The most ancient materials used for recording events were bricks, tiles, shells, and tables of stone. The modes of writing on these different substances were various. The tiles and brick were impressed with a stamp when in a soft state; the shells and tablets of

The most ancient materials used for recording events were bricks, tiles, shells, and tables of stone. The modes of writing on these different substances were various. The tiles

The most ancient materials used for recording events were bricks, tiles, shells, and tables of stone. The modes of writing on these different substances were various. The tiles

ABCDEFGHIJKLMNOPQRSTUVWXYZ&

ABCDEFGHIJKLMNOPQRSTUVWXYZ&

abcdefghijklmnopqrstuvwxyz

abcdefghijklmnopqrstuvwxyz

1 2 3 4 5 6 7 8 9 0

1 2 3 4 5 6 7 8 9 0

, . ; ! ? (|) ' ' ' * - — a a a m m m m @ £ \$ []

, . ; ! ? (|) ' ' ' * - — f f f f f f f f @ £ \$ []

¼ ½ ¾ ⅓ ⅔ ⅖ ⅘

⅛ ¼ ⅜ ½ ⅝ ¾ ⅞

Table characters. Figures and figure space .070; double figure space .140; comma, period, and quotations .035. These sizes will be sent unless otherwise ordered.

Alignment. 5½-point Bold Face No. 1 aligns with all 5½-point one- and two-letter faces except German. 10-point Clarendon aligns with all 10-point one- and two-letter faces except German.

Will run in all machines.

To avoid errors read notice on page six

SPECIMENS OF LINOTYPE FACES

51-POINT
BOLD FACE NO. 1
WITH
10-POINT
CLARENDON NO. 1
Two-Letter

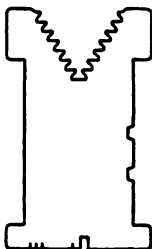

SPECIAL
CHARACTERS

Æ œ Œ œ - /
Æ œ Œ œ - /

á à â ã ç è é ê ë ì í î ï ñ ò ó ô õ ö ù ú û
á à â ä å ç è é ê ë ì í î ï ñ ò ó ô õ ö ú û ü

½ ¾ ⅓ ⅔ ⅕ ⅖ ⅗ ⅘ ⅙ ⅚ ⅛ ⅜ ⅝ ⅞ ⅓ ⅔ ⅕ ⅖ ⅗ ⅘ ⅙ ⅚ ⅛ ⅜ ⅝ ⅞

One-Letter Matrices to be used for two-letter work.
 " " % R 3 5

MERGENTHALER LINOTYPE CO.

8-POINT IONIC WITH 10-POINT CLARENDON NO. 1 [TWO-LETTER]

Lower case alphabet 16.68 8-point and 12.51 10-point ems

The most ancient materials employed for recording events were bricks, tiles, shells, and tables of stone. The modes of writing on these different substances were various. The tiles and brick were impressed with a

The most ancient materials employed for recording events were bricks, tiles, shells, and tables of stone. The modes of writing on these different substances were various. The tiles and brick were impressed with a

The most ancient materials employed for recording events were bricks, tiles, shells, and tables of stone. The modes of writing on these different substances were various. The tiles

The most ancient materials employed for recording events were bricks, tiles, shells, and tables of stone. The modes of writing on these different substances were various. The tiles

ABCDEFGHIJKLMNOPQRSTUVWXYZ&

ABCDEFGHIJKLMNOPQRSTUVWXYZ&

abcdefghijklmnopqrstuvwxyz

abcdefghijklmnopqrstuvwxyz

1 2 3 4 5 6 7 8 9 0

1 2 3 4 5 6 7 8 9 0

, . : ; ! P (|) * ' - — ñ ñ ñ ñ ñ ñ @ £ \$ []

, . : ; ! ? (|) * ' - — ñ ñ ñ ñ ñ ñ @ £ \$ []

1/8 1/4 3/8 1/2 5/8 3/4 7/8

1/8 1/4 3/8 1/2 5/8 3/4 7/8

Table characters. Figures and figure space .070; double figure space .140; comma, period, and quotations .035. These sizes will be sent unless otherwise ordered.

Alignment. 8-point Ionic No. 1 aligns with all 8-point one- and two-letter faces having high alignment except German. 10-point Clarendon No. 1 aligns with all 10-point one- and two-letter faces except German.

Will run in all machines.

To avoid errors read notice on page six

SPECIMENS OF LINOTYPE FACES

8-POINT
 IONIC NO. 1
 WITH
 10-POINT
 CLARENDON NO. 1
 Two-Letter

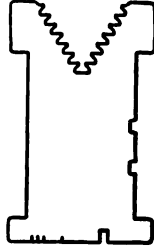

SPECIAL
 CHARACTERS

Low Cap Accents—Regular mold may be used.

À Ê Ì Ñ Ó Ū

Á É Í Ñ Ó Ū Ū

á é í ñ ó ü ú

á é í ñ ó ü ú

Æ œ Œ œ - ¡ ¢

Æ œ Œ œ - ¡ ¢

1/3 2/3 1/5 2/5 3/5 4/5 1/6 5/6

1/3 2/3 1/5 2/5 3/5 4/5 1/6 5/6

One-Letter Matrices to be used for two-letter work.

+ - × ÷ =

MERGENTHALER LINOTYPE CO.

8-POINT GOTHIC NO. 3 WITH 10-POINT CLARENDON NO. 1 [TWO-LETTER]

Lower case alphabet 15.10 8-point and 12.07 10-point ems

The most ancient materials used for recording events were bricks, tiles, shells, and tables of stone. The modes of writing on these different substances were various. The tiles and brick were impressed with a stamp when in

The most ancient materials used for recording events were bricks, tiles, shells, and tables of stone. The modes of writing on these different substances were various. The tiles and brick were impressed with a stamp when in

The most ancient materials used for recording events were bricks, tiles, shells and tables of stone. The modes of writing on these different substances were various. The tiles and

The most ancient materials used for recording events were bricks, tiles, shells and tables of stone. The modes of writing on these different substances were various. The tiles and

ABCDEFGHIJKLMN OPQRSTUVWXYZ&
ABCDEFGHIJKLMN OPQRSTUVWXYZ&
abcdefghijklmnopqrstu vwxyz
abcdefghijklmnopqrstu vwxyz

1 2 3 4 5 6 7 8 9 0

1 2 3 4 5 6 7 8 9 0

, . : ; ! ? (|) * ' ' - — fi ff ffi fff th @ £ \$ []

, . : ; ! ? (|) * ' ' - — fi ff ffi fff th @ £ \$ []

1/8 1/4 3/8 1/2 5/8 3/4 7/8

1/8 1/4 3/8 1/2 5/8 3/4 7/8

Table characters. Figures and figure space .070; double figure space .140; comma, period, and quotations .035. These sizes will be sent unless otherwise ordered.

Alignment. 8-point Gothic No. 3 aligns with all 8-point one- and two-letter faces having high alignment except German. 10-point Clarendon aligns with all 10-point one- and two-letter faces except German.

Will run in all machines.

To avoid errors read notice on page six

MERGENTHALER LINOTYPE CO.

10-POINT BOLD FACE ITALIC NO. 2 WITH CLARENDON NO. 1
[TWO-LETTER]

Lower case alphabet 12.96 ems

The most ancient materials used for recording events were bricks, tiles, shells, and tables of stone. The modes of writing on these different substances were various. The tiles and brick were impressed with a stamp when
The most ancient materials used for recording events were bricks, tiles, shells, and tables of stone. The modes of writing on these different substances were various. The tiles and brick were impressed with a stamp when

The most ancient materials used for recording events were bricks, tiles, shells, and tables of stone. The modes of writing on these different substances were various. The tiles and brick were impressed with a
The most ancient materials used for recording events were bricks, tiles, shells, and tables of stone. The modes of writing on these different substances were various. The tiles and brick were impressed with a

**ABCDEFGHIJKLMN OPQRSTUVWXYZ &
 ABCDEFGHIJKLMN OPQRSTUVWXYZ &**

**abcdefghijklmnopqrstuvwxyz
 abcdefghijklmnopqrstuvwxyz**

**1 2 3 4 5 6 7 8 9 0
 1 2 3 4 5 6 7 8 9 0**

**, . ; ! ? (|) * ' - — . . . ß ß ß ß ß ß ß @ £ \$
 , . ; ! ? (|) * ' - — . . . ß ß ß ß ß ß ß @ £ \$**

One-Letter Matrices

[]

Special set table characters. Figures and figure space .077; double figure space .154; comma, period, and quotations .0385. These sizes will be sent unless otherwise ordered.

Alignment. This face aligns with all 10-point one- and two-letter faces except German.

NOTE. The Bold Face Italic shown in this combination is our regular 7-point Bold Face Italic No. 1 made to align with 10-point.

Will run in all machines.

To avoid errors read notice on page six

MERGENTHALER LINOTYPE CO.

8-POINT UNILINE WITH TITLE NO. 1 [TWO-LETTER]

Lower case alphabet 12.09 ems

The most ancient materials employed for recording events were bricks, tiles, shells, and tables of stone. The modes of writing on these different substances were various. The tiles and brick were impressed with a stamp when in a soft state; the shells and tablets of stone were etched or graven, the figures or characters

The most ancient materials employed for recording events were bricks, tiles, shells, and tables of stone. The modes of writing on these different substances were various. The tiles and brick were impressed with a stamp when in a soft state; the shells and tablets of stone were etched or graven, the figures or characters

The most ancient materials employed for recording events were bricks, tiles, shells, and tables of stone. The modes of writing on these different substances were various. The tiles and brick were impressed with a stamp when in a soft state; the shells and

The most ancient materials employed for recording events were bricks, tiles, shells, and tables of stone. The modes of writing on these different substances were various. The tiles and brick were impressed with a stamp when in a soft state; the shells and

ABCDEFGHIJKLMNOPQRSTUVWXYZ&
ABCDEFGHIJKLMNOPQRSTUVWXYZ&

abcdefghijklmnopqrstuvwxyz

abcdefghijklmnopqrstuvwxyz

1 2 3 4 5 6 7 8 9 0

1 2 3 4 5 6 7 8 9 0

, . : ; ! ? (|) * ' ' - — fi fl ff ffi ffl @ lb £ \$ []

, . : ; ! ? (|) * ' ' - — fi fl ff ffi ffl @ lb £ \$ []

1/8 1/4 3/8 1/2 5/8 3/4 7/8

1/8 1/4 3/8 1/2 5/8 3/4 7/8

True set table characters. Figures and en quad .0553; em quad .1107; comma, period, and quotations .0277. Unit system 1/4-point basis. These sizes will be sent unless otherwise ordered.

Substitute table characters for use with this face can be had as follows: 8-point Uniline with Title No. 1 Modernized figures.—Figures and en quad .0553; em quad .1107.

Alignment. This face aligns with all 8-point one- and two-letter faces having low alignment except German.

Will run in all machines.

To avoid errors read notice on page six

MERGENTHALER LINOTYPE CO.

10-POINT UNILINE WITH TITLE NO. 1
 [TWO-LETTER]

Lower case alphabet 12.94 ems

The most ancient materials employed for recording events were bricks, tiles, shells, and tables of stone. The modes of writing on these different substances were various. The tiles and brick were impressed with

The most ancient materials employed for recording events were bricks, tiles, shells, and tables of stone. The modes of writing on these different substances were various. The tiles and brick were impressed with

The most ancient materials used for recording events were bricks, tiles, shells, and tables of stone. The modes of writing on these different substances were varied. The tiles and brick were impressed with

The most ancient materials used for recording events were bricks, tiles, shells, and tables of stone. The modes of writing on these different substances were varied. The tiles and brick were impressed with

ABCDEFGHIJKLMN OPQRSTUVWXYZ&
 ABCDEFGHIJKLMN OPQRSTUVWXYZ&

abcdefghijklmnopqrstuvwxy z
 abcdefghijklmnopqrstuvwxy z

1 2 3 4 5 6 7 8 9 0
 i 2 3 4 5 6 7 8 9 0

, . : ; ! ? (|) * ' ' - — . . . fi fl ff ffi ffl lb @ £ \$ []
 , . : ; ! ? (|) * ' ' - — . . . fi fl ff ffi ffl lb @ £ \$ []

1/8 1/4 3/8 1/2 5/8 3/4 7/8
 1/8 1/4 3/8 1/2 5/8 3/4 7/8

True set table characters. Figures and en quad .0691; em quad .1383; comma, period, and quotations .0346. Unit system, 1/4-point basis. These sizes will be sent unless otherwise ordered.

Substitute table characters for use with this face can be had as follows: 10-point Uniline with Title No. 1 Modernized figures.

Alignment. This face aligns with all 10-point one- and two-letter faces except German.

Will run in all machines.

To avoid errors read notice on page six

MERGENTHALER LINOTYPE CO.

10-POINT ANTIQUE NO. 3 WITH 12-POINT GOTHIC NO. 1
[TWO-LETTER]

Lower case alphabet 14.30 10-point and 11.92 12-point ems

The most ancient materials employed for recording events were bricks, tiles, shells, and tables of stone. The modes of writing on these differ-

The most ancient materials employed for recording events were bricks, tiles, shells, and tables of stone. The modes of writing on these differ-

The most ancient materials employed for recording events were bricks, tiles, shells, and tables of stone. The modes of

The most ancient materials employed for recording events were bricks, tiles, shells, and tables of stone. The modes of

ABCDEFGHIJKLMN OPQRSTUVWXYZ &
ABCDEFGHIJKLMN OPQRSTUVWXYZ &
abcdefghijklmnopqrstuvwxy z
abcdefghijklmnopqrstuvwxy z

1 2 3 4 5 6 7 8 9 0

1 2 3 4 5 6 7 8 9 0

, . : ; ! ? (|) * ' " - — . . . fi fl ff ffi ffl @ lb £ \$ []
, . : ; ! ? (|) * ' " - — . . . fi fl ff ffi ffl @ lb £ \$ []

$\frac{1}{8}$ $\frac{1}{4}$ $\frac{3}{8}$ $\frac{1}{2}$ $\frac{5}{8}$ $\frac{3}{4}$ $\frac{7}{8}$
 $\frac{1}{8}$ $\frac{1}{4}$ $\frac{3}{8}$ $\frac{1}{2}$ $\frac{5}{8}$ $\frac{3}{4}$ $\frac{7}{8}$

Special set table characters. Figures and figure space .0899; double figure space .1798; comma, period, and quotations .0449. Unit system 1/4-point basis.

Alignment. The 10-point Antique No. 3 aligns with all 10-point faces except German; the 12-point Gothic No. 1 aligns with all 12-point faces having low alignment except German. These faces will not align with each other if cast on the same slug.

Will run in all machines.

To avoid errors read notice on page six

SPECIMENS OF LINOTYPE FACES

**10-POINT
ANTIQUE NO. 3
WITH
12-POINT
GOTHIC NO. 1
Two-Letter**

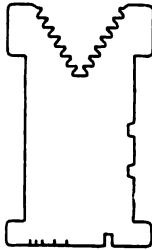

**SPECIAL
CHARACTERS**

Æ æ Œ œ
Æ æ Œ œ

§ || ¶ † ‡ - /
§ || ¶ † ‡ - /

1/3 2/3 1/5 2/5 3/5 4/5 1/6 5/6
1/3 2/3 1/5 2/5 3/5 4/5 1/6 5/6

MERGENTHALER LINOTYPE CO.

12-POINT GOTHIC NO. 5 WITH 12-POINT GOTHIC NO. 1
[TWO-LETTER]

Lower case alphabet 12.20 ems

The most ancient materials used for recording events were bricks, tiles, shells, and tables of stone. The modes of writing on these different substances were various. The tiles and brick
The most ancient materials used for recording events were bricks, tiles, shells, and tables of stone. The modes of writing on these different substances were various. The tiles and brick

The most ancient materials used for recording events were bricks, tiles, shells, and tables of stone. The modes of writing on these different substan-

The most ancient materials used for recording events were bricks, tiles, shells, and tables of stone. The modes of writing on these different substan-

ABCDEFGHIJKLMN OPQRSTUVWXYZ &
ABCDEFGHIJKLMN OPQRSTUVWXYZ &

abcdefghijklmnopqrstuvwxy z

abcdefghijklmnopqrstuvwxy z

1 2 3 4 5 6 7 8 9 0

1 2 3 4 5 6 7 8 9 0

, . : ; ! ? (|) * ' ' - — --- _ _ _ _ _ fi fl ff ffi ffi tb @ £ \$ []
, . : ; ! ? (|) * ' ' - — --- _ _ _ _ _ fi fl ff ffi ffi tb @ £ \$ []

Special set table characters. Figures and figure space .091; double figure space .182.

Alignment. These faces have special alignment and will not align with our other 12-point faces

Will run in all machines.

To avoid errors read notice on page six

SPECIMENS OF LINOTYPE FACES

12-POINT
 GOTHIC NO. 5
 WITH
 12-POINT
 GOTHIC NO. 1
 Two-Letter

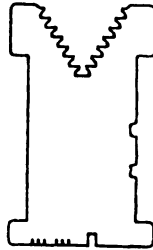

SPECIAL
 CHARACTERS

Ā Ā Ç É Ê Ì Ñ Ó Ô Õ Ü Ü
 Ā Ā Ç É Ê Ì Ñ Ó Ô Õ Ü Ü
 á à â ã ä å ç è é ê ë ì í î ï ñ ò ó ô õ ö ù ú û ü
 á à â ã ä å ç è é ê ë ì í î ï ñ ò ó ô õ ö ù ú û
 § || ¶ † ‡ - ¢ ¤ i " "
 § || ¶ † ‡ - ¢ ¤ i " "
 Æ æ Œ œ
 Æ æ Œ œ

One-letter matrices to be used for two-letter work.



Superior: 1 2 3 4 5 6 7 8 9 0

☼ ☺ ☾ ☽ ● ○ ⊕ ⊗ △ * ♀ ♀ † ♂
 ♂ ♂ Ω ℘ † ∩ ∩ ♂ ♂ ♂ ♂ Π Ψ ℋ ℤ ✕
 ≡ ℏ ℓ ℓ Δ □ ∠ ≡ ≡ √ < > ± ∓ ∴ ∴ ∴ ∴
 ☛ # ' " ° " « » ¶ * ¶ m/n % % % % ☛
 ☛ ⸮ ⸮ ⸮ ⸮ ⸮ ⸮ ⸮ ☛

MERGENTHALER LINOTYPE CO.

11-POINT ANTIQUE NO. 3 WITH DE VINNE ITALIC
[TWO-LETTER]

Lower case alphabet 13.41 ems

The most ancient materials used for recording events were bricks, tiles, shells, and tables of stone. The modes of writing on these different substances were various. The tiles and brick

The most ancient materials used for recording events were bricks, tiles, shells, and tables of stone. The modes of writing on these different substances were various. The tiles and brick

The most ancient materials employed for recording events were bricks, tiles, shells, and tables of stone. The modes of writing on these different sub-

The most ancient materials employed for recording events were bricks, tiles, shells, and tables of stone. The modes of writing on these different sub-

**ABCDEFGHIJKLMN OPQRSTUVWXYZ &
ABCDEFGHIJKLMN OPQRSTUVWXYZ &**

**abcdefghijklmnopqrstuvwxy z
abcdefghijklmnopqrstuvwxy z**

**1 2 3 4 5 6 7 8 9 0
1 2 3 4 5 6 7 8 9 0**

**, . : ; ! ? (|) * ' ' - — . . . fi ff ffi ffl lb @ £ \$ []
, . : ; ! ? (|) * ' ' - — . . . fi ff ffi ffl lb @ £ \$ []**

True set table characters. Figures and en quad .077; em quad .154; comma, period, and quotations .0385. These sizes will be sent unless otherwise ordered.

Alignment. This face aligns with all 11-point one and two-letter faces except German.

Will run in all machines.



DISPLAY
Characters

TWO-LINE INITIAL MATRICES AND ATTACHMENTS

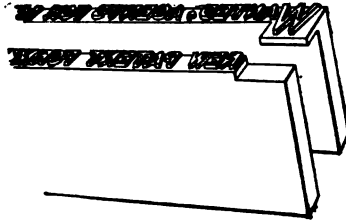

The Two-Line Initial letters shown in this circular are produced as shown in the cut. The 12-point letters are cast on a 6-point slug, the 11-point letters on a $5\frac{1}{2}$ -point slug, and the 10-point letters on a 5-point slug. The initial letter is put in the assembler with the first line of the item being set. The metal flows in and makes a complete face of the large letter which overhangs the bottom of the first slug as shown in the cut. In the second line the initial letter is raised to the auxiliary position so that it will not cast, but will leave a blank on the end of the slug.

When two slugs are placed together the overhanging letter on the first slug will rest on top of the second slug, making an initial covering the two lines in depth.

Special trimming knives are required for these characters.

Price of knife attachment and alphabet of matrices \$25.00, single matrices as sorts 3 cents each.

SPECIMENS OF LINOTYPE FACES

10-Point Two-Line — One-Letter Matrices
5-Point No. 10 with Gothic No. 4 — Two-Letter Matrices

GIRL—Wanted to assist in office; will be taught to operate the typewriter and write short hand. Address, Moses Steingold, Nickel Plating Company, 1234 19th St., Jersey City, N. J.

LEARNERS—On gumpes and children's dresses from \$14 to 20; paid while learning. Address, Whitestone & Skindoe, 23 Dooski St., Hoboken, L. I.

MEN—500 wanted to operate the Linotype machine in China; must be sober and non-users of tobacco. Apply to Won Lung, Sporting Editor of the Choy Suey Gazette.

\$1 DOWN and \$1 a week buys one of our Wuest Brothers Pianos; as we are the only agents for this piano you might better take the advantage of this offer as it will not appear in print again. Heller Piano Co., 13 W 14th St., Newark, N. Y.

SAFES New and second hand, of all kinds bought sold and exchanged; repairs of all kinds promptly made. We are agents for the Farvia Safe Co., Limited, Old Road, London, and the Sherrins Company, Edinburgh, Scotland.

\$20 Buys one of the very latest makes of \$20 phonographs; including a dozen gold \$20 mold records. Come and see our assortment of new records, any of which can be had for nine cents each. The Myrtle Phonograph Emporium, 69 Myrtle Av.

SUITS Now is the time to buy Easter Suits for the boys; here is the place to find the best and largest variety of clothes in the Greater New York at lowest prices. **\$1.98** Satin Foulards that are being sold over the country for 50 per cent. more than we have been selling them. We are giving them to the public while they last; per yard.....

\$1.24 **SUITS**

LIST OF CHARACTERS.

ABCDEFGHIJKLMN OPQRSTUVWXYZ &
1 2 3 4 5 6 7 8 9 0 \$ c e i n o p r s t
. . : ; ? ! ' () * - - Æ Œ £ ¼ ½ ¾

11-Point Two-Line — One-Letter Matrices
5½-Point No. 2 — One-Letter Matrices

EVENTS of New York, recorded in a book; a big hit; no agent makes less than \$100 a day selling it. We have room for about a million more dispensers. Agents must furnish moving van for deliveries. Address MILLER SYNDICATE, 234 Floyd St., Brooklyn.

LINOTYPE operator; the best there is can get the money here; only those that can set six thousand an hour need apply. Gutenberg Press, Williamsburg, N. Y.

STENOGRAPHERS; must be of the first-class and not afraid to do a little hard work once in a while; wages to start, \$2.25; must have at least six references; no bond required. Address WILL. E. GETHECUSH, 14 Prospect Park.

That is Tea; for 45 cents a pound; we **T** are introducing this new production, and **T** it is limited at this price. THE GOE TEA COMPANY, Goshen, R. I.

I examined free, by the best experts in town; our one-dollar-glasses, the talk of the city. THE SEAWELL COMPANY, Point Lookout.

LIST OF CHARACTERS.

ABCDEFGHIJKLMN OPQRSTUVWXYZ &
1 2 3 4 5 6 7 8 9 0
. . : ; ? ! () ' ' - -
¼ ⅜ ½ ¾ ⅓ Æ Œ / £ \$. ; i Ñ c

MERGENTHALER LINOTYPE CO.

12-Point Two Line — One-Letter Matrices
6-Point No. 2 — One-Letter Matrices

BURGLARY taught in four lessons, on easy terms; \$5 down the balance from first occupation. Work guaranteed for the first three months. Address **BURGLARS TRUST**, 13 Lute St., Swagville.

ASTRONOMER, with twelve years experience on Mars. Would prefer place with aerial navigation company as guide. Address **HI. FLIER**, 23 Neptune Av.

\$10 STANDARD typewriter in perfect condition; cost \$87.53. \$5.00 can have it. **F. A. KERR**, 219 Fifth avenue.

YOUNG MAN—MUST BE GOOD PEN- man, accurate figurer, industrious and honest; small salary for start; reference. **SMALL & CO.**, 438 Mortimer St.

\$39 Two slightly used Maple Uprights, good as new. Steinway. Sacrifice. Instalments, \$5.00. Rents, \$3.00 up. **BOODLE**, 11 W. 15th st.

WATCHMAN—SOBER YOUNG GER- man wants position as night or day watchman; first-class recommendation by last employer. **C. B. 546 E. 156th st.**

LIST OF CHARACTERS.

ABCDEFGHIJKLMNOPQRSTUVWXYZ&
 1 2 3 4 5 6 7 8 9 0 \$
 . ' c ? ! -

20-Point Gothic No. 1 Two Line — One-Letter Matrices
10-Point De Vinne with Antique No. 3 — Two-Letter Matrices

Silk Collar Bone, the finest quality; per gro., \$5, per doz. **45c**

Hercules Hump Hook with invisible eye; per gross. . . . **19c**

Whalebone, Genuine Shell Whalebone; 36-inch strips, per dozen **\$1.75**

Seam Bindings, 4¼ line Taffeta Silk Seam Binding; dozen pieces **89c**

Basting Cotton, 500 yards, to a spool; dozen spools. . . . **43c**

4½ line Taffeta Silk Seam Binding; dozen pieces. . . **\$1.50**

LIST OF CHARACTERS.

1 2 3 4 5 6 7 8 9 0
 \$, . c

SPECIMENS OF LINOTYPE FACES

SECTIONAL ADVERTISING FIGURES

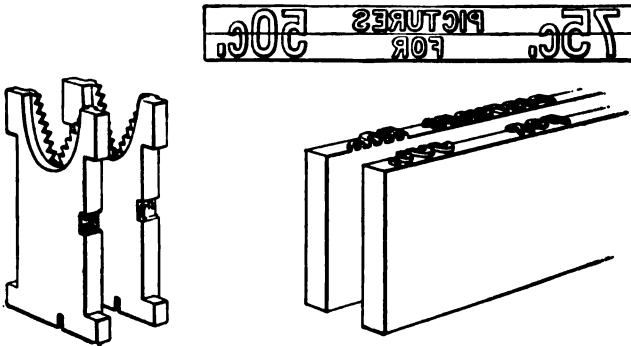

The two-piece or sectional characters are made in a different manner from the solid or two-line initial characters. The upper half of the character is on one matrix, the lower half on another (except the two-letter sets, where both are on the same matrix in the regular and auxiliary positions).

To use these matrices, place the matrix containing the upper half of the character you desire to produce in the assembler with the first line of the item you are setting, then place the matrix containing the lower half of the letter in the second line of the item, and when the two slugs are placed together they make the large or two-line characters, as shown in the illustration. These letters and figures are very useful for advertising purposes.

The 11-point two-piece characters cast on two $5\frac{1}{2}$ -point slugs, the 12-point on two 6-point slugs, the 16-point on two 8-point slugs, and the 24-point on two 10-point slugs.

These matrices are sold as sorts, each matrix containing but one-half of the character, at 3 cents each, making the total of each complete character 6 cents.

MERGENTHALER LINOTYPE CO.

12-Point Gothic No. 4 Sectional—One-Letter Matrices
 6-Point No. 2 with Bold Face No. 1—Two-Letter Matrices

LINEN LUSTRES—Half linen—coarse but soft weave, that makes up into smart tailored Costumes and Children's Russian Dresses—Reseda, Light, Medium and dark Blue, Gunmetal, Rose, Pink, Brown, Hello—never intended to sell under 19c. Our price..... **14c**

FINE FANCY ORGANDIES—White with dainty colored flower designs, Black-and-Crimson cross stripes and a few other nice selections including Dresden effects—elsewhere 19c..... **11c**

TAFFETA CHECKS—Silk styles and colors—look and make up like silk—all colors, also Black-and-White—Elsewhere .25—here.... **18c**

Specially fine assortment of **PLAID** and **CHECK GINGHAMS** for Children's Dresses—Bright colored Scotch Plaids, Plain and Combination Checks on white and colored grounds, also solid colors with corded bars, also Silk Mixed Novelties—all recommended for washing and good wearing qualities..... **17c to 49c**

LIST OF CHARACTERS.

1 2 3 4 5 6 7 8 9 0
1 2 3 4 5 6 7 8 9 0
¢ / , . £ ¢
¢ / , ; . L 3

16-Point Gothic No. 1 Sectional—One-Letter Matrices
 8-Point No. 2 with Condensed Title No. 3—Two-Letter Matrices

ROSEWOOD PIANO STOOL
 A most desirable up to date Baby Model..... **98c**

1 BEHR BROS UPRIGHT
 Elegant large Rosewood Piano. Full rich tone.... **\$200**

1 HORACE WATERS UPRIGHT
 Very handsome Rosewood case Piano, as good as new **\$175**

1 BAUER UPRIGHT
 Walnut case, excellent condition. Just the piano for a small apartment **\$135**

1 SMALL BABY GRAND
 Excellent condition, splendid tone with sympathetic action. Original cost \$700..... **\$270**

LIST OF CHARACTERS.

1 2 3 4 5 6 7 8 9 0 ¢ , . 1/ 1/ 3/
1 2 3 4 5 6 7 8 9 0 ¢ , . ¢ 7/2 7/4 7/4

SPECIMENS OF LINOTYPE FACES

24-Point Gothic No. 1 Sectional—One-Letter Matrices

10-Point French Old Style—Two-Letter Matrices

NAINSOOK SHIELDS—Our fully guaranteed "Princess" Brand, crescent shape, sizes 2, 3 and 4, long flap; light weight, washable. Per dozen pairs, \$1. 3 pairs for..... **25c**

OZ. SPOOL SILK—"La Perfection Brand," Oz. Spool Silk in black and white, letters OO to D. Special sale price, per doz. spools \$4.75; per spool **46c**

WARR'S FEATHERBONE—A big price-slashing on Warr's Silk Gros Grain Featherbone—gross \$8; a dozen yards for..... **69c**

SILK SOUTACHE BRAID—At our Sale you can buy a 24-yard piece of this fine Silk Soutache Braid black only, for only..... **\$1.37**

LIST OF CHARACTERS.

1 2 3 4 5 6 7 8 9 0
1 2 3 4 5 6 7 8 9 0
¢ ¢ 1/ 1/ 3/
¢ , ¢ 7/4 7/2 7/4

12-Point Gothic No. 4 Sectional—Two-Letter Matrices

6-Point De Vinne with Antique No. 3—Two-Letter Matrices

BOYS' SUITS—Sailor or Russian blouse models, made of wool cassimeres and chevots; sailor collars, emblems on the shields and collars; sizes 2½ to 10 years \$4.00 values, Tuesday sale.... **\$2.97**

GIRLS' DRESSES—High Neck Dresses, made of figured percales; full blouses, trimmed with stitched bands of plain percale; full pleated skirt with deep hem; 4 to 14-year sizes, \$5.50 values..... **85c**

99c WOMEN'S LAWN WAISTS 99c
Made of fine white lawn, entire front is box-pleated and tucked; tucked collar and a Val. yoke, Monday sale price.

OPTICAL GOODS—Skeleton Eye-Glasses, 10-karat gold mountings, "Cantship" guards; fitted with finest French periscope lenses; a real \$3.50 value, to go at the Tuesday sale **\$1.74**

LIST OF CHARACTERS.

1 2 3 4 5 6 7 8 9 0 ¢ / . ¢ ¢
1 2 3 4 5 6 7 8 9 0 ¢ / . ¢ ¢

TWO-PIECE LETTERS AND FIGURES

(TWO-LETTER MATRICES)

These matrices differ from the one-letter in that they have the complete character on each matrix, the upper half of the character being in the auxiliary position and the lower half in the standard position. They are used in the same manner as the one-letter matrices, except that to obtain the upper half of the letter or figure, the matrix is placed in the upper or auxiliary position, and to obtain the lower half, the matrix is dropped to the standard position in the second line, and when the two slugs are placed together they form the two-line letter or figure covering the first two lines of the item being set.

Price of two-piece two-letter matrices $4\frac{1}{2}$ cents each, each matrix producing a complete letter or figure.

SPECIMENS OF LINOTYPE FACES

16-Point Gothic No. 1 Sectional—Two-Letter Matrices
8-Point No. 2 with Gothic No. 3—Two-Letter Matrices

SMOKED SHOULDERS.

Delicious little picnics, very lean and tender; 4 to 6 lbs.; at less than wholesale, a lb..... **10c**

BONELESS BACON.

Swift's Eagle Brand; best sugar cured, famous for its rare flavor; every slice streaks of fat and lean; at less than wholesale, a lb **23c**

SMOKED BEEF.

Blue Ribbon Brand—Sliced fresh; no waste; absolutely clean; a doz. in a box... **\$1.05**

PANCAKE FLOUR.

Aunt Dinah's—prepared and self-raising; has no equal for muffins and pancakes; pkg..... **68c**

LIST OF CHARACTERS.

**1 2 3 4 5 6 7 8 9 0
 1 2 3 4 5 6 7 8 9 0**

**¢ ½
 ¢ , ¢ ½**

24-Point Gothic No. 1 Sectional—Two-Letter Matrices
10-Point De Vinne with Antique No. 3—Two-Letter Matrices

11c each for extra heavy hem-stitched **HUCK TOWELS**, with a pretty red border. No less than a half dozen to each buyer.

\$1.29 a yard, 36 in. width, for our \$1.69 **BLACK TAF-FETA SILK**. This sale will close at 11 o'clock sharp.

8¾c a yard for fine **WHITE VICTORIA LAWN**, 40 in. wide; reg. 14c. quality; 10 o'clock sale only.

41½c a yard for our bleached **MUSLIN**, 36 in. width, a lot of remnants. **Must be closed out at this sale.**

LIST OF CHARACTERS.

**1 2 3 4 5 6 7 8 9 0
 1 2 3 4 5 6 7 8 9 0**

**¢ ½ ¾
 ¢ , ¢ ¼ ½ ¾**

MERGENTHALER LINOTYPE CO.

11-Point Two Line Sectional—Two-Letter Matrices

5½-Point No. 2—One-Letter Matrices

GIRLS—Experienced chocolate dippers or girls willing to learn. Henry Heide, Hudson and Vandam sts.

NICE upright piano, full size, in good order. 146 Lefferts place, Brookkloy. No dealers.

PRESSER—Woman to press infants' and children's cloaks and make herself useful. Neu. 41 Mercer st., near Grand.

STORE FIXTURES, ice boxes, counters, shelving, cases, scales, coffee mills. MEYERS, 22d st., corner 3d ave.

30 Typewriters, all standard makes rented and kept in order, ribbons free; machines sold from 20 to 50 per cent. less than manufacturers' prices. F. S. WEBSTER CO., 10 Park Place. Telephone, 8570 Cortlandt.

\$125 Buys UPRIGHT PIANO, celebrated make, full size; a bargain; payments as desired. PEASE, 657 Fulton st., Brooklyn.

\$45 Upright, good order, Steinway; bargain. Call to-day. Storage Warehouse, 416 East 76th st.

LIST OF CHARACTERS.

A B C D E F G H I J K L M N O P Q R S T U V W X Y Z &
 A B C D E F G H I J K L M N O P Q R S T U V W X Y Z &

1 2 3 4 5 6 7 8 9 0
 1 2 3 4 5 6 7 8 9 0

@ ^ , . ' ' - ? !
 @ ^ , . ' ' - ? !

12-Point Two Line Sectional—Two-Letter Matrices

6-Point No. 2—One-Letter Matrices

FREE LOTS TO EVERYBODY IN Greater New York who buys two or more of the Beautiful "Cumsetter" lots; \$290, \$340 and \$490 each, no higher. Free tickets on application at the Franklin Realty Co., 89 Ryerson St., Hoboken, Ia.

DOGS I have two full-bred English and two French bulldogs; imported for a rich fancier who died. Will sell them for \$75 each. Address Box 2041.

\$175 BUYS a slightly used Steinway cost \$450 new; can be seen any day but Sunday at owners home. 173 East 104th St., Jersey City, N. J.

IT OUR SEWING MACHINE IS **IT** because the sale has made the reputation which has won first prize at all world's fairs in the last decade; nuff sed. Call at our salesrooms and see some of our specimens. Richmond, Staten Island, N. Y.

B BROAD SILK WEAVERS—Wanted, experienced on Jacquard and Shafts; a good job the year round. For further particulars apply Myrtle Silk Co., Salem, Miss.

M MACHINISTS wanted, milling hands, on heavy castings. Apply Union Ballast Co., Bedford Ave, and Prospect Park West, Manhattan Borough, New York City, N. Y.

LIST OF CHARACTERS.

A B C D E F G H I J K L M N O P Q R S T U V W X Y Z &
 A B C D E F G H I J K L M N O P Q R S T U V W X Y Z &

1 2 3 4 5 6 7 8 9 0 @ ^ , . ' ' - ? ! / &
 1 2 3 4 5 6 7 8 9 0 @ ^ , . ' ' - ? ! / &



*Rogers Tabular
System*

MERGENTHALER LINOTYPE CO.

BY THIS SYSTEM, invented by Mr. J. R. Rogers and adopted by the Linotype Company, it becomes possible to set rule and figure matter and tables in general on the Linotype machine with rapidity and accuracy and at a cost below that possible under any other system.

The appliances for this work are quickly applicable to all existing Linotype machines.

The machine produces the ordinary horizontal slugs, having therein slots to receive shallow brass rules. The slugs are delivered from the machine with the slots therein, and no sawing, cutting or other treatment is necessary. After the proofs are pulled and corrections made, the rules may be inserted in an instant, and when the form is locked up the rules are held securely in place.

SPECIMENS OF LINOTYPE FACES

51-POINT GOTHIC NO. 3, ROGERS TABULAR SYSTEM

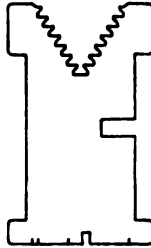

A. P. PARDOE & COMPANY	147,545.06	\$120.00	2.389
LEHIGH VALLEY COMPANY	797,139.43	283.20	21,389
MILLIKIN COAL MINES	288,711.90	789.01	28,786
MAKLOWSKY COLLIERY	270,356.35	211.39	36,840
A. S. VAN WICK	674,168.12	1,287.09	17,564
C. M. DODSOIL	327,934.36	231.45	94,028
MONTGOMERY & STONE	903,560.37	177.33	80,655
WILSON & BARRET	222,039.50	257.18	82,363
ARDCOLE & TONNER	903,353.40	293.40	18,744
CURRIE, COMBE & COMPANY	377,459.31	299.00	43,210
CROSS, AUSTIN & COMPANY	983,037.84	712.34	39,236
MILLS BIGG COMPANY	856,930.82	172.89	90,807
RIBSON MINING COMPANY	387,124.89	763.90	31,773
SIVERSTEIN & GOLDBURG	237,711.35	287.84	55,350
RILEY & ARMSTRONG	174,333.45	232.31	21,488
WILKES, BARRE & SON	281,346.38	782.93	82,172
CALKIN, PURDY & COMPANY	3,135,940.03	833.94	40,372
MILLIKIN COAL MINES	288,711.90	789.01	28,786
MILLS BIGG COMPANY	856,930.82	172.89	90,807
MAKLOWSKY COLLIERY	270,356.35	211.39	36,840
BOONE, DANIELS & BRO	117,945.78	278.94	90,821
NEWPORT MINING COMPANY	399,450.12	971.34	15,044
STEEN & COMPANY	580,392.17	878.39	82,842
FENNEWELL COMPANY	287,455.03	812.39	75,506
LEHIGH VALLEY COMPANY	797,139.43	283.20	21,389
RIBSON MINING COMPANY	387,124.89	763.90	31,773
WILSON & BARRET	222,039.50	287.18	82,363



To avoid errors read notice on page six

MERGENTHALER LINOTYPE CO.

51-POINT BOLD FACE NO. 1, ROGERS TABULAR SYSTEM

\$15,109,673	78,594	\$43,516	.0029	55.4	\$574,845
2,640,149	15,326	4,622	.0017	30.1	79,650
125,413	1,211	130	.0010	10.7	146,896
2,846,969	21,320	8,761	.0031	41.1	139,630
437,122	2,904	1,385	.0032	47.7	680,915
1,585,433	14,052	3,900	.0025	27.8	88,350
5,992,489	51,115	34,192	.0057	66.8	307,412
76,198,015	438,613	114,617	.0015	26.1	394,890
293,850	2,738	163	.0006	5.9	4,778,362
					555,100
5,714,322	42,551	15,202	.0027	35.7	4,500
489,870	3,966	5,040	.0065	127.1	718,490
17,725,695	118,402	55,634	.0031	46.9	182,175
12,064,564	82,514	36,946	.0031	44.7	5,616,503
49,524,157	254,255	60,964	.0012	23.9	1,141,609
26,793,967	167,368	74,342	.0028	44.4	4,643,309
8,502,893	55,559	33,280	.0039	59.8	1,358,710
986,947	8,939	911	.0009	10.2	480,049
169,948	1,458	28	.0001	7.9	381,805
6,828,568	60,524	19,579	.0029	32.3	59,775
24,402,969	166,916	44,453	.0018	26.6	415,000
15,357,903	108,646	45,796	.0029	44.0	2,500,844
8,357,903	75,522	39,140	.0046	51.8	910,095
120,065,144	607,883	151,206	.0012	24.8	608,611
8,259,009	57,452	16,100	.0019	28.0	4,540,700
4,542,316	35,772	20,532	.0045	57.3	587,375
2,224,117	14,445	6,034	.0027	41.7	475,045
27,733,678	183,046	119,231	.0043	65.1	133,377
2,219,257	16,672	12,729	.0057	76.3	2,481,691
					1,660,757

List of Regular and Special Characters.

1 2 3 4 5 6 7 8 9 0
 . * \$ - — . . .
 § † ‡

To avoid errors read notice on page six

MERGENTHALER LINOTYPE CO.

6-POINT GOTHIC NO. 6, ROGERS TABULAR SYSTEM

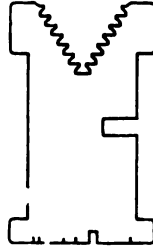

214,746,951	555,418	115,293	.0032	27.5	149,120	12,438	44,000	55,000	16,078	18,975
4,875,068	88,304	37,976	.0078	43.0	349,400	4,322	1,701	5,025	8,250	7,856
1,174,847	13,965	11,745	0.099	84.1	246,796	4,029	1,482	5,874	6,123	9,872
5,030,148	16,496	84,841	.0056	39.1	930,381	3,705	5,836	3,720	4,280	9,840
2,141,146	22,334	14,284	.0067	63.9	472,801	5,991	745	3,250	4,312	8,723
9,148,303	83,338	86,519	.0094	47.1	11,040	7,398	1,178	3,517	4,830	5,116
2,864,432	39,313	90,350	.0083	43.3	279,505	7,843	6,739	8,405	4,290	5,204
1,199,752	21,431	10,107	.0084	47.1	628,498	9,371	4,457	5,840	3,920	4,283
6,562,842	14,459	33,216	.0091	46.6	864,218	8,203	9,875	4,234	8,970	2,120
5,999,869	30,307	73,329	.0023	24.1	560,697	6,083	3,884	5,430	2,789	4,350
6,562,842	14,459	33,216	.0091	46.6	864,218	8,203	9,875	4,234	8,970	2,120
5,999,869	30,307	73,329	.0023	24.1	560,697	6,083	3,884	5,430	2,789	4,350
7,961,589	32,894	79,789	.0101	54.0	657,372	3,705	1,314	2,438	5,930	2,783
4,150,850	90,176	85,461	.0082	48.3	998,748	3,447	8,298	3,450	7,182	9,143
718,492	9,666	2,346	.0033	23.2	745,831	8,383	210	345	7,340	8,729
894,853	15,056	8,372	.0054	64.1	21,000	217	35	4,394	7,839	7,134
1,199,752	21,431	10,107	.0084	47.1	628,498	9,371	4,457	5,840	3,920	4,283
4,875,068	88,304	37,976	.0078	43.0	349,400	4,322	1,701	5,025	8,250	7,856
5,030,148	16,496	84,841	.0056	39.1	930,381	3,705	5,836	3,720	4,280	9,840
1,174,847	13,965	11,745	0.099	84.1	246,796	4,029	1,482	5,874	6,123	9,872
2,864,432	39,313	90,350	.0083	43.3	279,505	7,843	6,739	8,405	4,290	5,204
2,141,146	22,334	14,284	.0067	63.9	472,801	5,991	745	3,250	4,312	8,723
9,148,303	83,338	86,519	.0094	47.1	11,040	7,398	1,178	3,517	4,830	5,116
165,824	3,178	6	.0034	0.2	345,089	5,297	451	7,493	8,238	7,123
2,270,589	95,129	34,388	.0105	59.3	578,608	5,762	9,191	3,290	1,340	7,832

. . . * 1 2 3 4 5 6 7 8 9 0 _ _ _ _

8 7 6 5 4 3 2 1 - 0 9 8 7 6 5 4 3 2 1 0

To avoid errors read notice on page six

MERGENTHALER LINOTYPE CO.

6-POINT GERMAN NO. 1, ROGERS TABULAR SYSTEM

1897	-----	\$1,764,344	\$21,356	14,872	2.0084	55,418,390
1890	-----	4,820,608	31,750	12,729	8.0026	14,459,466
1890	-----	9,639,958	64,716	29,170	4.0030	13,965,000
1890	-----	27,273,932	104,928	58,853	7.0021	88,304,563
1901	-----	311,645	2,756	218	5.0007	16,496,013
1888	-----	445,183	2,560	254	3.0005	21,431,299
1893	-----	5,650,944	38,295	19,116	9.0094	22,334,180
1890	-----	29,837,800	150,957	43,611	8.0015	15,056,288
1890	-----	4,820,608	31,750	12,729	8.0026	14,459,466
1896	-----	3,473,054	21,072	4,453	1.0013	9,686,047
1890	-----	29,837,800	150,957	43,611	8.0015	15,056,288
1888	-----	445,183	2,560	58,853	7.0021	88,304,849
1893	-----	5,650,944	38,295	19,116	9.0094	22,334,180
1890	-----	9,639,958	64,716	29,170	4.0030	13,965,000
1898	-----	1,124,009	9,056	1,080	9.0009	83,338,548
1882	-----	4,585,416	39,500	20,700	7.0005	39,313,846
1890	-----	27,273,932	164,928	58,853	7.0021	88,304,849
1903	-----	49,800	683	-----	-----	30,307,849

1 2 3 4 5 6 7 8 9 0

. . . * \$ - - -

i i i i i i i i i i i i i i i i

[8 7 4 : A P M } | } J |]

To avoid errors read notice on page six

MERGENTHALER LINOTYPE CO.

8-POINT OLD STYLE NO. 1, LOW ALIGNMENT, ROGERS TABULAR SYSTEM

\$27,433,287.00	309,405.22	\$124,895,370	*4,539,721.36
621,394,431.28	222,389.34	671,392,917	405,817,312.83
288,402,792.30	948,785.68	89,271,439	28,731,039.33
83,945,017.00	406,432.23	289,306,721	27,902,545.09
409,550,823.43	376,938.97	896,219,233	221,456,478.34
142,399,871.56	503,217.36	782,190,355	382,031,322.16
244,063,170.49	129,340.42	174,305,711	904,287,714.35
287,346,903.50	817,290.59	177,384,556	212,346,122.17
571,727,394.54	372,949.50	284,346,921	490,805,276.39
394,453,506.28	403,592.59	327,400,211	366,278,190.30
621,394,431.28	222,389.34	671,392,917	405,817,312.83
142,399,871.56	503,217.36	782,190,355	382,031,322.16
287,340,903.50	817,290.59	177,384,556	212,346,122.17
95,837,430.34	92,390.40	215,371,493	598,372,859.37
807,593,278.02	409,378.24	890,563,872	305,860,396.44
288,402,792.30	948,785.68	89,271,439	28,731,039.33
808,371,356.35	238,395.07	825,270,501	402,856,840.73
450,813,489.32	387,456.94	718,593,872	377,207,592.55
244,063,170.49	129,340.42	174,305,711	904,287,714.35

1 2 3 4 5 6 7 8 9 0
 , . - - — \$ *
 A P M || § ¶ † ‡ * % []
 a b g D J L M S V
 $\frac{1}{8}$ $\frac{1}{4}$ $\frac{3}{8}$ $\frac{1}{2}$ $\frac{5}{8}$ $\frac{3}{4}$ $\frac{7}{8}$ 1 1 1 1 1 1 1 1 1 1

To avoid errors read notice on page six

SPECIMENS OF LINOTYPE FACES

8-POINT GOTHIC NO. 6, ROGERS TABULAR SYSTEM HIGH AND LOW ALIGNMENT

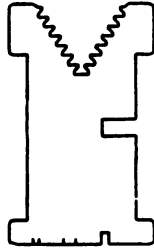

14,748,951	155,418	115,293	.0032	27.5	149,120	2,438	4,000	1,800
4,875,088	88,304	37,976	.0078	43.0	349,400	4,322	1,701	3,900
1,174,847	13,965	11,745	.0099	84.1	248,796	4,029	1,492	3,700
5,030,148	18,496	84,841	.0056	39.1	930,381	3,705	5,836	4,200
1,199,752	21,431	10,107	.0084	47.1	628,488	9,371	4,457	4,700
6,562,842	14,459	33,218	.0081	46.6	864,218	8,203	9,875	4,300
718,492	9,668	2,348	.0033	23.2	745,831	8,383	210	2,500
894,853	15,058	8,372	-----	-----	1,500	39	4,564	-----
2,500	22	272	-----	-----	21,000	217	25	-----
7,738,683	42,933	11,911	.0063	46.0	954,201	2,480	3,548	2,800
2,141,148	22,334	14,284	.0067	63.9	472,801	5,891	745	1,200
9,148,303	83,336	88,519	.0084	47.1	11,040	7,398	1,178	6,400
2,884,432	39,313	90,350	.0083	43.3	279,505	7,843	6,739	2,400
5,999,889	30,307	73,329	.0028	24.1	1580,697	6,083	3,884	1,400
7,981,589	32,894	79,789	.0101	54.0	857,372	3,705	1,314	3,600
4,150,859	90,178	85,481	.0082	48.3	998,748	3,447	8,298	4,200
165,824	2,178	6	-----	0.2	345,089	5,297	451	8,800

. . 1 2 3 4 5 6 7 8 9 0 - - - -
 § ¶ || † ‡ § † § † § † § † § † § - - - - 1234567890
 A P M - = am pm %

To avoid errors read notice on page six

MERGENTHALER LINOTYPE CO.

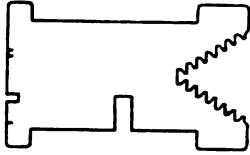

2-POINT IONIC NO. 1, ROGERS TABULAR SYSTEM

Casters for Butter Workers-----	19	\$0.35	19	\$0.35	19	\$0.35	19	\$0.35
Axle Shafts for B. Workers-----	*019	.60	*19	.75	*19	.75	*19	.75
Looking Lugs-----	20	.15	20	.15	20	.15	20	.15
Miter Gears for Butter Workers-----	021	.30	21	.50	*21	.50	*21	.50
Rear Box-----	17	.60	22	.125	22	1.25	22	1.25
Rear Collar-----	38	.25	23	.35	23	.35	23	.35
Clutch Lever-----	024	.50	24	.75	24	.75	24	.75
Cream Hole Cover Frame-----	025	.25	25	.35	25	.35	25	.35
Rings for Glass-----	026	.15	26	.15	26	.15	26	.15
Rear Cream Hole Flange-----			27	.40	27	.40	27	.40
Cover Levers-----	028	.10	28	.10	28	.10	28	.10
Cover Lugs-----	029	.10	29	.20	29	.20	29	.20
Belt Shifter Arms-----	*030	.30	*30	.25	*30	.25	*30	.25
Belt Shifter Fingers-----	†30	.20	†30	.20	†30	.20	†30	.20
Belt Shifter Stop Pin-----	‡30	.10	‡30	.10	‡30	.10	‡30	.10
Guard Rail Brace-----	031	.30	31	.40	31	.40	31	.40

List of Regular and Special Characters.

ABCDEFGHIJKLMN O PQRSTU VWXYZ&

abcdefghijklmnopqrstuvwxyz

1234567890

, . : ; P I () * - - - - - \$
 ... A P M 123456780 § † ‡
 } † ‡ § † ‡ § † ‡ § † ‡ §
 @ m | } { { | } , . % #

To avoid errors read notice on page six

SPECIMENS OF LINOTYPE FACES

8-POINT IONIC NO. 4, ROGERS TABULAR SYSTEM

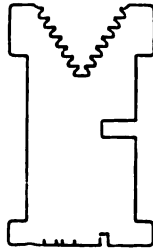

\$29,900 00	\$125,500 00	\$280,981	\$35,220 00
202,900 00	7,891,892 51	2,498,014	92,099 00	811,150 81
416,700 00	492,224 85	1,710,979	178,801 65	198,297 89
67,500 00	196,899 00	524,206	81,237 50	33,942 59
146,865 00	458,684	37,671 46
.....	211,700 00	628,741	1,000 00	31,261 19
122,516 01	1,911,516 00	774,077	9,001 08
279,000 00	288,880 00	2,299,450	197,500 00	89,751 28
49,200 00	216,771 17	145,591	1,000 00	33,047 92
307,500 00	818,901 00	354,384	57,900 00	108,975 16
7,500 00	247,207 18	8,168	77,200 00	63,828 16
385,775 60	1,316,000 00	5,341,622	9,800 00	88,291 95
255,500 00	68,350 00	155,422	76,557 68
416,700 00	492,224 85	1,710,979	178,801 65	198,297 89
401,205 62	454,733 76	4,569,888	18,400 00	769,625 96
401,205 62	454,733 76	4,569,888	18,400 00	769,625 98

1 2 3 4 5 6 7 8 9 0

, . - * . — ..
 § † ‡ A P M \$ †
 3 1 2 2 2 2 2 2 2

To avoid errors read notice on page six

MERGENTHALER LINOTYPE CO.

8-POINT GERMAN NO. 1, ROGERS TABULAR SYSTEM

Atlanta, Ga.-----	\$22.50	\$40.00	\$19.50	\$28.00
Augusta, Ga.-----	21.50	35.00	18.00	24.50
Birmingham, Ala.-----	24.50	44.60	22.00	25.00
Chattanooga, Tenn.-----	23.25	42.30	20.75	30.00
Tampa, Fla.-----	24.50	44.50	21.50	23.00
DeLand Fla.-----	24.85	43.70	18.84	24.55
Fernandina, Fla.-----	21.50	37.00	15.00	25.80
Jacksonville, Fla.-----	21.50	37.00	15.50	24.60
Lake City, Fla.-----	23.30	40.60	17.30	22.50
Macon, Ga.-----	22.00	38.70	19.00	30.75
Memphis, Tenn.-----	25.50	-----	23.25	26.75
Miami, Fla.-----	32.50	59.00	26.50	23.50
St. Augustine, Fla.-----	22.75	39.50	16.75	24.25
Tampa, Fla.-----	24.50	44.50	21.50	23.00
Thomasville, Ga.-----	24.50	44.50	21.50	25.00

ABCDEFGHIJKLMN OPQRSTUVWXYZ&

abcdefghijklm nopqrstuvwxyz

, . : ; ? ! - — ' * _ _ _ fi fi fi fi @ ID

§ † ‡ - \$ £ []

To avoid errors read notice on page six

SPECIMENS OF LINOTYPE FACES

10-POINT NO. 6, ROGERS TABULAR SYSTEM

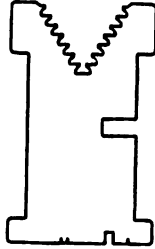

\$4,746,951	\$55,418	\$15,293	.0032	27.5	\$149,120	\$243
4,875,068	88,304	37,976	.0078	43.0	349,400	432
1,174,847	13,965	11,745	.0099	84.1	246,796	429
5,030,148	16,496	84,841	.0056	39.1	930,381	375
1,199,752	21,431	10,107	.0084	47.1	628,498	937
6,562,842	14,459	33,216	.0091	46.6	864,218	820
718,492	9,666	2,346	.0033	24.2	745,831	838
894,853	15,056	8,372	-----	-----	1,500	390
2,500	22	272	-----	-----	21,000	217
7,738,683	42,933	11,911	.0063	46.0	954,201	249
2,141,146	22,384	14,284	.0067	63.9	472,801	589
9,148,303	83,338	86,519	.0094	47.1	11,040	738
2,864,432	39,313	90,350	.0083	43.3	279,505	784
5,999,869	30,307	73,329	.0028	24.1	657,372	370

, . 1 2 3 4 5 6 7 8 9 0 \$ * - - - -

§ ¶ || † ‡ -

To avoid errors read notice on page six

MERGENTHALER LINOTYPE CO.

10-POINT NO. 13, ROGERS TABULAR SYSTEM

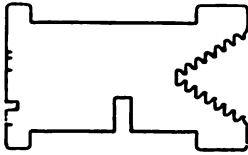

\$29,900 00	\$125,500 00	\$280,961	\$35,220 00	\$43,662,927	\$712,430
202,900 00	7,891,892 51	2,498,014	92,099 00	311,150 31	516,384,245
416,700 00	492,234 85	1,710,979	178,301 65	193,297 39	69,500,754
67,500 00	196,899 00	524,206	31,237 50	33,942 59	14,298,931
146,865 00	428,684	37,671 46	25,200,668
122,516 01	1,911,516 00	774,077	9,001 08	35,186,553
.....	211,700 00	628,741	1,000 00	31,261 19	11,617,550
279,000 00	233,880 00	2,299,450	197,500 00	89,751 26	65,222,531
49,200 00	216,771 17	145,591	1,000 00	33,047 92	56,896,394
307,500 00	813,901 00	354,384	57,900 00	103,975 16	114,927,959
7,500 00	247,307 13	8,166	77,200 00	63,828 16	23,770,556
385,775 60	1,316,000 00	5,341,622	9,800 00	88,291 95	32,418,994
255,500 00	66,350 00	155,422	76,557 66	11,813,771
401,205 62	454,733 76	4,569,888	13,400 00	759,625 96	88,923,669

List of Regular and Special Characters.

L 2 3 4 5 6 7 8 9 0 \$
 A P M sm sm
 || S ¶ † *
 .. - - - - -

To avoid errors read notice on page six

SPECIMENS OF LINOTYPE FACES

10-POINT NO. 1, ROGERS TABULAR SYSTEM

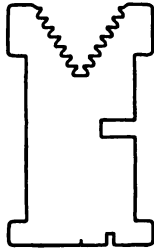

13	Alder Creek..Cal.	22.25	32.50	46.75	50.00
14	Orchard	23.25	33.50	47.75	51.10
15	Folsom	25.25	35.50	48.75	52.10
16	Cothrin	25.25	35.50	49.75	54.10
17	Latrobe	26.25	36.50	49.75	55.10
18	Flonellis	27.25	37.50	50.75	56.10
19	Brela	28.25	38.50	51.75	57.75
20	Brandon	29.25	39.50	51.75	57.10
21	Dugan	29.25	39.50	52.75	59.10
22	Bennett	31.25	41.50	53.75	60.10
23	Shingle	32.25	42.50	53.75	61.10
24	Cummings ...	33.25	43.50	54.75	62.10
25	El Dorado....	34.25	44.50	55.75	63.10
26	Diamond	35.25	45.50	56.75	64.10

ABCDEFGHIJKLMN O PQRSTU VWXYZ&

abcdefghijklmnopqrstu vwxyz

1 2 3 4 5 6 7 8 9 0

, . : ; ? ! - ' () * \$. . fi ff ffi ffl

1/8 1/4 3/8 1/2 5/8 3/4 7/8 1/3 2/3 1/5 2/5 3/5 4/5 1/6 5/6

1/8 1/4 3/8 1/2 5/8 3/4 7/8 1/3 2/3 1/5 2/5 3/5 4/5 1/6 5/6

Æ œ Œ œ £ ¢ / || § ¶ † ‡ - - - - - [-]



To avoid errors read notice on page six

MERGENTHALER LINOTYPE CO.

10-POINT ANTIQUE NO. 3, ROGERS TABULAR MATRICES

44,746,951	155,418	115,293	.0032	27.5	149,120	24.34
14,875,068	188,304	137,976	.0078	43.0	349,400	44.32
11,174,847	113,965	111,745	.0099	84.1	246,796	42.99
55,030,148	616,496	884,841	.0056	39.1	930,381	37.53
19,199,752	221,431	110,107	.0084	47.1	628,498	93.77
66,562,842	414,459	333,216	.0091	46.6	864,218	82.00
718,492	9,666	2,346	.0033	24.2	745,831	83.88
894,853	15,056	8,372	-----	-----	1,500	39.00
2,500	22	272	-----	-----	21,000	21.71
7,738,683	42,933	11,911	.0063	46.0	954,201	24.96
2,141,146	22,334	14,284	.0067	63.9	472,801	58.98
9,148,303	83,338	86,519	.0094	47.1	11,040	73.85
2,864,432	39,313	90,350	.0083	43.3	279,505	78.44
5,999,869	30,307	73,329	.0028	24.1	657,372	37.00

, . 1 2 3 4 5 6 7 8 9 0 - - - - -

§ || ¶ † ‡

A P M

To avoid errors read notice on page six

SPECIMENS OF LINOTYPE FACES

10-POINT OLD STYLE NO. 1, ROGERS TABULAR SYSTEM

\$15,109,673	178,594	\$43,516.37	.0025	55.4
125,413	1,211	130.27	.0010	41.1
79,198,015	438,613	114,617.23	.0015	5.9
8,327,493	217,490	90,503.39	.0091	33.4
12,344,032	178,955	111,238.50	.1097	23.1
88,393,403	390,536	232,435.07	.0095	39.8
9,809,545	839,405	87,015.33	.0030	13.3
45,902,278	449,822	343,554.90	.0077	45.9
34,432,991	9,456	221,785.37	.1004	2.9
9,342,034	17,555	27,049.40	.0009	23.0
93,407,503	89,493	123,456.78	.0129	90.8
88,775,520	109,822	87,230.39	.0428	37.1
84,402,709	99,063	89,301.43	.0987	28.1
155,712,933	294,401	90,560.31	.1002	87.1

1 2 3 4 5 6 7 8 9 0

, . * \$ - - -

+ + - % % - § † ‡ A P M

To avoid errors read notice on page six

MERGENTHALER LINOTYPE CO.

7-POINT OLD STYLE NO. 1. ROGERS TABULAR SYSTEM

1-----	\$1,125,283 00	\$280,951 00	3,933,450	283,711
2-----	2,789,044 00	170,365 00	1,277,700	802,145
3-----	11,834,055 90	304,930 28	1,899,043	796,275
4-----	3,882,407 00	401,279 34	2,213,394	487,210
5-----	1,720,321 00	371,895 13	3,786,178	390,909
6-----	2,117,397 00	487,099 45	2,934,366	90,344
7-----	2,831,718 00	872,394 44	1,838,235	23,091
8-----	8,246,801 13	579,132 96	2,244,038	128,811
9-----	1,777,283 04	930,217 33	6,317,213	98,725
10-----	4,303,246 38	639,321 31	5,348,172	242,355
11-----	3,403,327 00	279,280 34	3,400,325	88,439
12-----	5,348,271 49	272,393 36	3,280,150	312,830
13-----	1,228,310 33	712,812 17	9,387,194	70,131
14-----	1,707,226 35	454,218 39	5,324,463	28,381
15-----	3,460,313 71	330,105 54	2,387,783	49,218
16-----	1,722,794 34	217,398 45	1,230,796	75,455
17-----	2,812,340 04	314,464 17	2,101,298	19,308
18-----	9,807,315 23	394,490 64	2,999,037	87,120

1 2 3 4 5 6 7 8 9 0

, . * \$ -

† ‡ § + + - % % -

To avoid errors read notice on page six

SPECIMENS OF LINOTYPE FACES

12-POINT NO. 1, ROGERS TABULAR SYSTEM

97.....	\$1,764,344	\$32,409	\$29,822
98.....	38,227,712	89,345	17,820
99.....	9,639,340	139,037	30,451
100.....	311,645	2,461	643
101.....	535,831	3,098	436
102.....	271,824	2,461	2,178
103.....	712,394	355	22,382
104.....	2,543,210	37,273	33,935
105.....	45,403,289	98,233	129,309
106.....	2,712,329	40,392	290,034
107.....	93,817	902,365
108.....	7,908,123	9,094	403,890

1 2 3 4 5 6 7 8 9 0

, . - * \$.. - - - - - .. || § ¶ † ‡ [-]

1 1 2 1 2 3 4 5 A P M

To avoid errors read notice on page six

VERTICAL SLUG TABLE MATRICES

These matrices differ from the ordinary matrices only in that the characters are punched horizontally or transversely in the edge instead of vertically.

The characters, on the vertical slug, appear one under another instead of one beside another, as on the usual slug. In making up the form, the vertical slugs are placed end up and arranged side by side.

For further information see our circular, "Tabular Matter and the Linotype."

**6-POINT NO. 2 VERTICAL SLUG TABLE MATRICES
[ONE-LETTER]**

1 2 3 4 5 6 7 8 9 0
- - - - -
Duplicate Character Matrices
Superior Figures

1 2 3 4 5 6 7 8 9 0
- - - - -
Duplicate Character Matrices
Superior Figures

8-POINT NO. 2 VERTICAL SLUG TABLE MATRICES

[ONE-LETTER]
1 2 3 4 5 6 7 8 9 0
- - - - -

Duplicate Character Matrices
Superior Figures

1 2 3 4 5 6 7 8 9 0
- - - - -
Duplicate Character Matrices
Superior Figures

**6-POINT NO. 2 WITH GOTHIC NO. 6 VERTICAL SLUG
TABLE MATRICES**

[TWO-LETTER]
1 2 3 4 5 6 7 8 9 0
- - - - -

Duplicate Character Matrices
Superior Figures

1 2 3 4 5 6 7 8 9 0
- - - - -
Duplicate Character Matrices
Superior Figures

**8-POINT NO. 2 WITH GOTHIC NO. 6 VERTICAL SLUG
TABLE MATRICES**

[TWO-LETTER]
1 2 3 4 5 6 7 8 9 0
- - - - -

Duplicate Character Matrices
Superior Figures

1 2 3 4 5 6 7 8 9 0
- - - - -
Duplicate Character Matrices
Superior Figures

SPECIMENS OF LINOTYPE FACES

6-POINT NO. 2 WITH IONIC NO. 3 VERTICAL SLUG TABLE MATRICES

[TWO-LETTER]

1 2 3 4 5 6 7 8 9 0

1 2 3 4 5 6 7 8 9 0

Duplicate Character Matrices
Superior Figures

. * | \$ % & ' () * = + - : ; < > ~
A M P T

8-POINT NO. 2 WITH IONIC NO. 3 VERTICAL SLUG TABLE MATRICES

[TWO-LETTER]

1 2 3 4 5 6 7 8 9 0

1 2 3 4 5 6 7 8 9 0

Duplicate Character Matrices
Superior Figures

. * | \$ % & ' () * = + - : ; < > ~
A M P T

10-POINT DE VINNE WITH ANTIQUE NO. 3 VERTICAL SLUG TABLE MATRICES

[TWO-LETTER]

1 2 3 4 5 6 7 8 9 0

1 2 3 4 5 6 7 8 9 0

Duplicate Character Matrices

. * | \$ % & ' () * = + - : ; < > ~
A M P T

12-POINT DE VINNE WITH ANTIQUE NO. 3 VERTICAL SLUG TABLE MATRICES

[TWO-LETTER]

1 2 3 4 5 6 7 8 9 0

1 2 3 4 5 6 7 8 9 0

Duplicate Character Matrices

. * | \$ % & ' () * = + - : ; < > ~
A M P T



*Miscellaneous
Part Fonts, etc.*

SPECIMENS OF LINOTYPE FACES

6-Point Old Style No. 1 Modernized Figures.—One-Letter

Size .042

1 2 3 4 5 6 7 8 9 0

6-Point No. 12 Figures with Old Style Small Caps.—Two-Letter

Size .050

1 2 3 4 5 6 7 8 9 0 \$
V B C D E F G R T J P

6-Point No. 12 Figures with Old Style Small Caps. Special No. 2

Two-Letter

Size .050

2 5 7
B E G

6-Point Old Style No. 1 Modernized Figures.—Two-Letter

Size .050

1 2 3 4 5 6 7 8 9 0
V B C D E F G R T J

6-Point Ronaldson Modernized Figures.—Two-Letter

Size .050

1 2 3 4 5 6 7 8 9 0
V B C D E F G R T J

6-Point Old Style No. 1 with Antique No. 1 Modernized Figures

Two-Letter

Size .050

1 2 3 4 5 6 7 8 9 0
1 2 3 4 5 6 7 8 9 0

6-Point De Vinne with Gothic No. 7.—Two-Letter

Size .056

1 2 3 4 5 6 7 8 9 0
1 2 3 4 5 6 7 8 9 0

6-Point No. 1 with Bold Face No. 1.—Two-Letter

Size .056

1 2 3 4 5 6 7 8 9 0 \$
1 2 3 4 5 6 7 8 9 0 \$

6-Point Bold Face No. 3.—One-Letter

Size .070

1 2 3 4 5 6 7 8 9 0 \$, . € £ — †

6-Point No. 1 with Clarendon No. 1.—Two-Letter

Size .050

1 2 3 4 5 6 7 8 9 0 \$, . c
1 2 3 4 5 6 7 8 9 0 \$, . c

6-Point No. 12 Figures with Ronaldson Small Caps.—Two-Letter

Size .050

1 2 3 4 5 6 7 8 9 0 \$
V B C D E F G R T J P

6-Point Gothic No. 2.—One-Letter

Size .056

. : | | * ' - @ \$ £ —
1/8 1/4 3/8 1/2 5/8 3/4 7/8 1 2 3 1/3 2/3 3/5 4/5 1/5 5/5
" ' ° † - - - - - c - + x x - + =
{ { { { } } } } { } { } { }

MERGENTHALER LINOTYPE CO.

6-Point No. 1.—One-Letter
Size .066

1 2 3 4 5 6 7 8 9 0 \$. . . — * £

7-Point Bold Face No. 1.—One-Letter
Size .084

1 2 3 4 5 6 7 8 9 0

¼ ½ ¾ ⅓ ⅔ ⅖ ⅘ ⅙ ⅛ ⅜ ⅝ ⅞ ⅐ ⅑ ⅒
 ⑈ ⑉ , . ; ! ? £ \$ c - - . [] - () * ❏ ❐

7-Point Doric to Align with 9-Point No. 13.—One-Letter
ABCDEFGHIJKLMN OPQRSTUVWXYZ

abcdefghijklmnopqrstuvwxyz
Size .077

1 2 3 4 5 6 7 8 9 0

, . ; ! ? () * ' - - ¨ ¨ ¨ ¨ ¨ []
 High Cap Accents—These require a special mold.

À Á Â Ã Ä Å Æ Ç È É Ê Ë Ì Í Î Ï Ñ

Low Cap Accents—Regular mold may be used.

à á â ã

æ ç è é

š ž š ž š ž š ž š ž š ž š ž

§ † + × = □

7-Point No. 21 Figures with Old Style Small Caps.—Two-Letter
Size .066

1 2 3 4 5 6 7 8 9 0

V B C D E F G R T J

7-Point No. 21 Figures with Ronaldson Small Caps.—Two-Letter
Size .066

1 2 3 4 5 6 7 8 9 0

V B C D E F G R T J

7-Point No. 1 with Bold Face No. 1.—Two-Letter
Size .069

1 2 3 4 5 6 7 8 9 0

1 2 3 4 5 6 7 8 9 0

. , * — . . . ¢ \$

. , * — ¢ \$

⅛ ¼ ⅜ ½ ⅝ ¾ ⅞

⅛ ¼ ⅜ ½ ⅝ ¾ ⅞

7-Point Bold Face No. 3.—One-Letter
Size .084

1 2 3 4 5 6 7 8 9 0

. , ; ¢ \$ ¼ ½ ¾ ⅓ ⅔

7-Point Old Style No. 1 with Antique No. 1 Modernized Figures
Two-Letter
Size .066

1 2 3 4 5 6 7 8 9 0

1 2 3 4 5 6 7 8 9 0

7-Point Caslon Modernized Figures.—Two-Letter
Size .066

1 2 3 4 5 6 7 8 9 0

V B C D E F G R T J

SPECIMENS OF LINOTYPE FACES

7-Point Old Style No. 1 Modernized Figures.—Two-Letter
Size .056

1 2 3 4 5 6 7 8 9 0
V B C D E F G R T J

7-Point No. 1 Small Caps with 7-Point Doric.—Two-Letter
A B C D E F G H I J K L M N O P Q R S T U V W X Y Z
a b c d e f g h i j k l m n o p q r s t u v w x y z

, . : ; - — ‘ ’
, . : ; - — ‘ ’

7-Point Gothic No. 3.—One-Letter
Size .070

1 2 3 4 5 6 7 8 9 0

7-Point Antique No. 1 Modernized Figures.—One-Letter
Size .0553

1 2 3 4 5 6 7 8 9 0

7-Point Title No. 2 Modernized Figures.—One-Letter
Size .0553

1 2 3 4 5 6 7 8 9 0

7-Point Bold Face No. 3.—One-Letter
To Align with 8-Point Low Aligning Faces
Size .084

1 2 3 4 5 6 7 8 9 0 \$.

7-Point Ronaldson Modernized Figures.—Two-Letter
Size .056

1 2 3 4 5 6 7 8 9 0
V B C D E F G R T J

7-Point Doric No. 1 Punched in Auxiliary Position.—One-Letter

ABCDEFGHIJKLMN OPQRSTUVWXYZ&
l m p ? ! (|) * . . . Æ æ Œ œ Đ @ £ \$ § []

Size .077
1 2 3 4 5 6 7 8 9 0
¼ ½ ¾ ⅓ ⅔ ⅛ ⅜ ⅝

8-Point Royal Gothic.—To Align on Bottom with 6-Point No. 2 Cap H

ABCDEFGHIJKLMN OPQRSTUVWXYZ&

, . -

8-Point Royal Gothic.—To Align in Center of 6-Point No. 2 Cap H

ABCDEFGHIJKLMN OPQRSTUVWXYZ&

, . -

8-Point Title No. 1 Modernized Figures.—One-Letter
Size .056

1 2 3 4 5 6 7 8 9 0

8-Point Title No. 2 Modernized Figures.—One-Letter
Size .070

1 2 3 4 5 6 7 8 9 0

8-Point Antique No. 1 Modernized Figures.—One-Letter
Size .059

1 2 3 4 5 6 7 8 9 0

MERGENTHALER LINOTYPE CO.

8-Point Old Style No. 1 with Antique No. 1 Modernized Figures
Two-Letter
Size .069

1 2 3 4 5 6 7 8 9 0
1 2 3 4 5 6 7 8 9 0

8-Point Caslon Modernized Figures.—Two-Letter
Size .066

1 2 3 4 5 6 7 8 9 0
V B C D E F G R T J

8-Point No. 19 with Title No. 1 Modernized Figures.—Two-Letter
Size .066

1 2 3 4 5 6 7 8 9 0
1 2 3 4 5 6 7 8 9 0

8-Point Old Style No. 1 Modernized Figures.—Two-Letter
Size .066

1 2 3 4 5 6 7 8 9 0
V B C D E F G R T J

8-Point Ronaldson Modernized Figures.—Two-Letter
Size .066

1 2 3 4 5 6 7 8 9 0
V B C D E F G R T J

8-Point Old Style No. 1 Modernized Figures with 6-Point No. 1 Figures
Two-Letter
Size .066

1 2 3 4 5 6 7 8 9 0
1 2 3 4 5 6 7 8 9 0

8-Point Old Style No. 1 Modernized Figures.—One-Letter
Size .066

1 2 3 4 5 6 7 8 9 0

8-Point Title No. 2 Modernized Figures.—Two-Letter
Size .070

1 2 3 4 5 6 7 8 9 0
1 2 3 4 5 6 7 8 9 0

8-Point Clarendon No. 1 Figures with 7-Point No. 1 Figures
Two-Letter
Size .059

1 2 3 4 5 6 7 8 9 0
1 2 3 4 5 6 7 8 9 0

8-Point No. 4 Figures with 8-Point Clarendon No. 1 Figures
Modern Alignment.—Two-Letter
Size .059

1 2 3 4 5 6 7 8 9 0 \$
1 2 3 4 5 6 7 8 9 0 \$

8-Point No. 4 Figures with 8-Point Clarendon No. 1 Figures
Old Style Alignment.—Two-Letter
Size .059

1 2 3 4 5 6 7 8 9 0 \$
1 2 3 4 5 6 7 8 9 0 \$

8-Point Old Style No. 1 Figures with 8-Point Clarendon No. 1 Figures
Two-Letter
Size .059

1 2 3 4 5 6 7 8 9 0 \$
1 2 3 4 5 6 7 8 9 0 \$

SPECIMENS OF LINOTYPE FACES

8-Point No. 4 Figures with Ronaldson Small Caps.—Two-Letter
Size .056

1 2 3 4 5 6 7 8 9 0 \$
V B C D E F G R T J P

8-Point No. 4 Figures with Old Style No. 1 Small Caps.—Two-Letter
Size .056

1 2 3 4 5 6 7 8 9 0 \$
V B C D E F G R T J P

8-Point No. 4 Figures with Old Style No. 1 Small Caps.—Two-letter
Special No. 2
Size .056

2 5 7
B E G

German 8-Point No. 1 Figures with Old Style No. 1 Small Caps
Two-Letter
Size .056

1 2 3 4 5 6 7 8 9 0 \$
V B C D E F G R T J P

German 8-Point No. 1 Figures with Ronaldson Small Caps
Two-Letter
Size .056

1 2 3 4 5 6 7 8 9 0 \$
V B C D E F G R T J P

8-Point Cambridge Modernized Figures.—Two-Letter
Size .0553

1 2 3 4 5 6 7 8 9 0
V B C D E F G R T J

8-Point Upline with Title No. 1 Modernized Figures.—Two-Letter
Size .0553

1 2 3 4 5 6 7 8 9 0
1 2 3 4 5 6 7 8 9 0

9-Point Old Style No. 1 Figures with 9-Point No. 13 Figures
Two-Letter
Size .063

I 2 3 4 5 6 7 8 9 0
1 2 3 4 5 6 7 8 9 0

9-Point No. 13 Figures with 9-Point Old Style Small Caps
Two-Letter
Size .063

1 2 3 4 5 6 7 8 9 0 \$
V B C D E F G R T J P

9-Point No. 13 Figures with 9-Point Ronaldson Small Caps
Two-Letter
Size .063

1 2 3 4 5 6 7 8 9 0 \$
V B C D E F G R T J P

9-Point Old Style No. 1 Modernized Figures.—Two-Letter
Size .063

1 2 3 4 5 6 7 8 9 0
V B C D E F G R T J

MERGENTHALER LINOTYPE CO.

9-Point Ronaldson Modernized Figures.—Two-Letter
Size .063

1 2 3 4 5 6 7 8 9 0
V B C D E F G R T J

9-Point Old Style No. 1 Modernized Figures.—One-Letter
Size .063

1 2 3 4 5 6 7 8 9 0

10-Point Bold Face No. 3.—One-Letter
Size .093

1 2 3 4 5 6 7 8 9 0 \$, . ; ¢ £ () —
1/8 1/4 3/8 1/2 5/8 3/4 7/8 1/3 2/3 1/5 2/5 3/5 4/5 1/6 5/6

10-Point Latin Italic.—One-Letter

E N S W , .

10-Point Old Style Gothic No. 1.—One-Letter
Size .070

1 2 3 4 5 6 7 8 9 0 .

10-Point No. 13 Figures with 10-Point Clarendon No. 1 Figures
Two-Letter
Size .070

1 2 3 4 5 6 7 8 9 0
1 2 3 4 5 6 7 8 9 0

10-Point Old Style No. 1 Figures with 10-Point Clarendon No. 1
Figures.—Two-Letter
Size .070

1 2 3 4 5 6 7 8 9 0 \$
1 2 3 4 5 6 7 8 9 0 \$

10-Point No. 13 Figures with Ronaldson Small Caps.—Two-Letter
Size .070

1 2 3 4 5 6 7 8 9 0 \$
V B C D E F G R T J P

10-Point No. 13 Figures with Old Style Small Caps.—Two-Letter
Size .070

1 2 3 4 5 6 7 8 9 0 \$
V B C D E F G R T J P

Special No. 2

2 5 7

B E G

10-Point Admiral.—One-Letter
Size .0899

1 2 3 4 5 6 7 8 9 0 \$ ¢ , .

SPECIMENS OF LINOTYPE FACES

10-Point Doric No. 1, Special.—One-Letter
Size .090

1 2 3 4 5 6 7 8 9 0, . ; c \$

10-Point Caslon Modernised Figures.—Two-Letter
Size .070

1 2 3 4 5 6 7 8 9 0

V B C D E F G R T J

10-Point Title No. 1 Modernised Figures.—One-Letter
Size .070

1 2 3 4 5 6 7 8 9 0

10-Point Title No. 2 Modernised Figures.—One-Letter
Size .070

1 2 3 4 5 6 7 8 9 0

10-Point Antique No. 1 Modernised Figures.—One-Letter
Size .070

1 2 3 4 5 6 7 8 9 0

10-Point Old Style No. 1 Modernised Figures.—Two-Letter
Size .070

1 2 3 4 5 6 7 8 9 0

V B C D E F G R T J

10-Point Ronaldson Modernised Figures.—Two-Letter
Size .070

1 2 3 4 5 6 7 8 9 0

V B C D E F G R T J

10-Point Old Style No. 1 with Antique No. 1 Modernised Figures
Two-Letter
Size .070

1 2 3 4 5 6 7 8 9 0

1 2 3 4 5 6 7 8 9 0

10-Point Old Style No. 1 Modernised Figures.—One-Letter
Size .070

1 2 3 4 5 6 7 8 9 0

10-Point Original Old Style Modernised Figures.—Two-Letter
Size .0692

1 2 3 4 5 6 7 8 9 0

V B C D E F G R T J

10-Point Upline with Title No. 1 Modernised Figures.—Two-Letter
Size .0692

1 2 3 4 5 6 7 8 9 0

1 2 3 4 5 6 7 8 9 0

11-Point Old Style No. 1 Modernised Figures.—One-Letter
Size .077

1 2 3 4 5 6 7 8 9 0

11-Point Bold Face No. 2.—One-Letter
Size .105

1 2 3 4 5 6 7 8 9 0

$\frac{1}{2}$ $\frac{1}{4}$ $\frac{3}{4}$. ; \$ c

$\frac{1}{8}$ $\frac{1}{4}$ $\frac{3}{8}$ $\frac{1}{2}$ $\frac{5}{8}$ $\frac{3}{4}$ $\frac{7}{8}$ $\frac{1}{3}$ $\frac{2}{3}$ $\frac{1}{5}$ $\frac{2}{5}$ $\frac{3}{5}$ $\frac{4}{5}$ $\frac{1}{6}$ $\frac{5}{6}$

MERGENTHALER LINOTYPE CO.

11-Point Bold Face No. 3 Duplicate Characters
Size .105

1 2 3 4 5 6 7 8 9 0 . , \$ ¢
1 2 3 4 5 6 7 8 9 0 . , \$ ¢

11-Point Old Style No. 1 with Antique No. 1 Modernized Figures
Two-Letter
Size .077

1 2 3 4 5 6 7 8 9 0
1 2 3 4 5 6 7 8 9 0

11-Point Old Style No. 1 Modernized Figures.—Two-Letter
Size .077

1 2 3 4 5 6 7 8 9 0
V B C D E F G R T J

11-Point Cambridge Modernized Figures.—Two-Letter
Size .0761

1 2 3 4 5 6 7 8 9 0
V B C D E F G R T J

11-Point Caslon Modernized Figures.—Two-Letter
Size .084

1 2 3 4 5 6 7 8 9 0
V B C D E F G R T J

11-Point Ronaldson Modernized Figures.—Two-Letter
Size .077

1 2 3 4 5 6 7 8 9 0 \$
V B C D E F G R T J P

11-Point No. 9 Figures with Ronaldson Small Caps.—Two-Letter
Size .077

1 2 3 4 5 6 7 8 9 0
V B C D E F G R T J

11-Point No. 9 Figures with Old Style Small Caps.—Two-Letter
Size .077

1 2 3 4 5 6 7 8 9 0
V B C D E F G R T J

11-Point No. 9 Figures with Clarendon No. 1 Figures.—Two-Letter
Size .077

1 2 3 4 5 6 7 8 9 0
1 2 3 4 5 6 7 8 9 0

12-Point No. 13 Figures with Clarendon No. 1 Figures.—Two-Letter
Size .084

1 2 3 4 5 6 7 8 9 0
1 2 3 4 5 6 7 8 9 0

SPECIMENS OF LINOTYPE FACES

12-Point Bold Face No. 3.—One-Letter
Size .112

1 2 3 4 5 6 7 8 9 0 . , \$ ¢

12-Point Caslon Modernized Figures.—Two-Letter
Size .084

**1 2 3 4 5 6 7 8 9 0
V B C D E F G R T J**

12-Point Old Style No. 1 Modernized Figures.—Two-Letter
Size .084

**1 2 3 4 5 6 7 8 9 0
V B C D E F G R T J**

12-Point Ronaldson Modernized Figures.—Two-Letter
Size .084

**1 2 3 4 5 6 7 8 9 0
V B C D E F G R T J**

12-Point Old Style No. 1 with Antique No. 1 Modernized Figures
Two-Letter
Size .084

**1 2 3 4 5 6 7 8 9 0
1 2 3 4 5 6 7 8 9 0**

12-POINT LINING GOTHIC NO. 1

ABCDEFGHIJKLMN OPQRSTUVWXYZ &

1 2 3 4 5 6 7 8 9 0

, . ; ! ? () ' ' - - . \$ ¢ Æ Œ

14-Point Original Old Style No. 1 Modernized Figures.—Two-Letter
Size .0988

**1 2 3 4 5 6 7 8 9 0
V B C D E F G R T J**

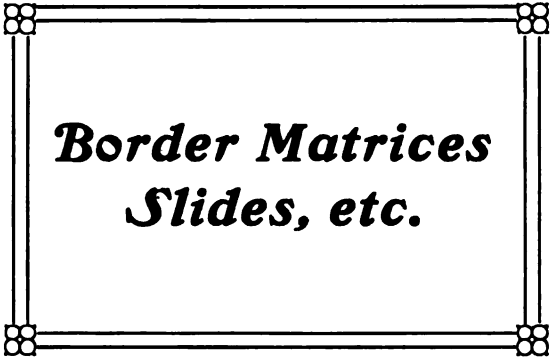

***Border Matrices
Slides, etc.***

**BORDER MATRICES AND
MATRIX SLIDES FOR BOR-
DERS, RULES AND DASHES.**

Two classes of matrices are shown herein:
BORDER MATRICES, similar to let-
ter matrices, to be assembled in lines and
used in any Linotype machine in connection
with the ordinary mold.

They do not demand the use of any extra
parts in the machine.

By setting these matrices of different
designs, in different combinations, a great
variety of effects may be produced.

Order by number, and note that corner-
pieces have special numbers.

PRICES:

Sets of 26 matrices.....\$2.50
Single matrices10

MATRIX SLIDES. These slides are
each complete in one piece, and are used in

SPECIMENS OF LINOTYPE FACES

the machine in connection with the regular mold.

NOTE that one quad block must be provided to sustain the slides, which can be substituted one for another at will.

These slide matrices produce borders, rules and dashes, in great variety, without joints or breaks therein, and in every way as perfect as those of brass.

Quad Blocks.

13½ to 30 ems.....\$2.00

13 ems and under..... 1.75

Matrix Slides, any pattern.

13½ to 30 ems.....\$1.25

13 ems and under..... 1.00



MERGENTHALER LINGTYPE CO.

5½ - P O I N T B O R D E R S

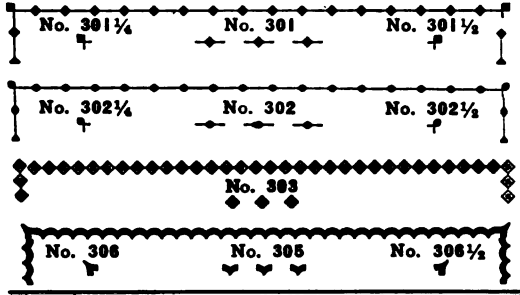

6 - P O I N T B O R D E R S

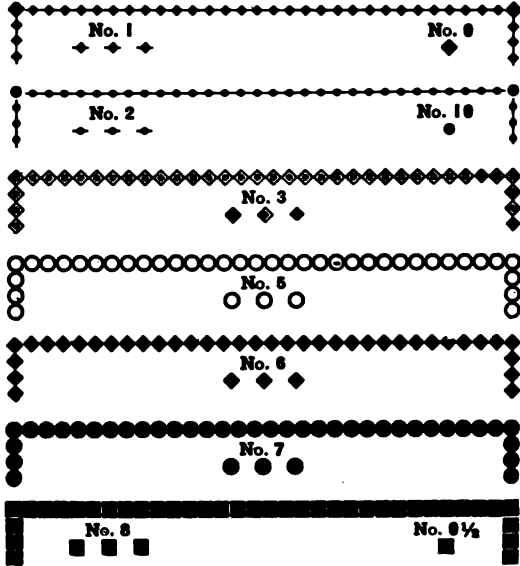

SPECIMENS OF LINOTYPE FACES

6 - P O I N T B O R D E R S

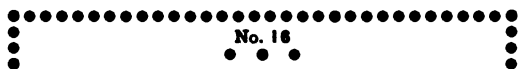
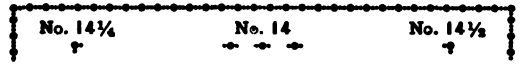
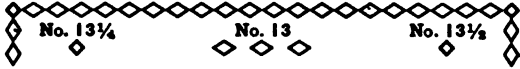
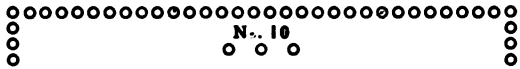
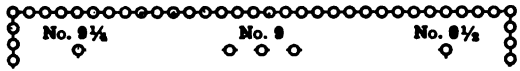

MERGENTHALER LINOTYPE CO.

6 - P O I N T B O R D E R S

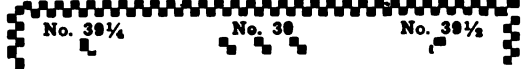
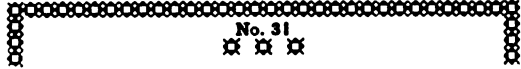
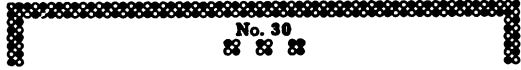
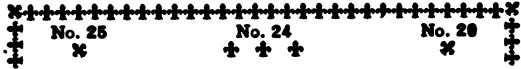
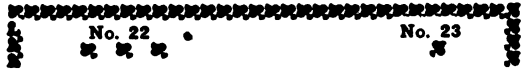
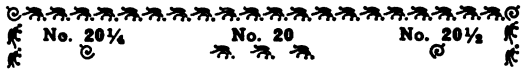
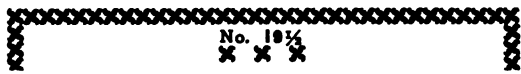

SPECIMENS OF LINOTYPE FACES

6 - P O I N T B O R D E R S

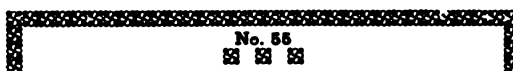
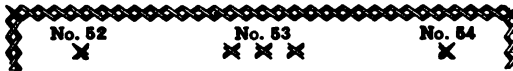
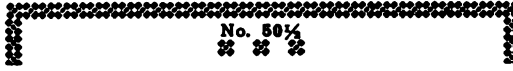
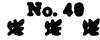
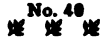
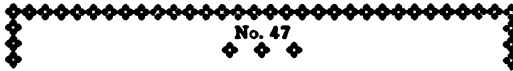
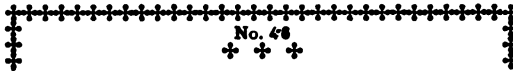
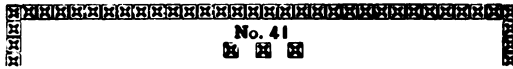

SPECIMENS OF LINOTYPE FACES

6 - P O I N T B O R D E R S

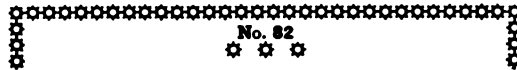
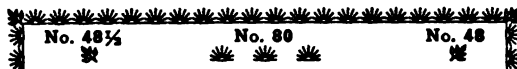
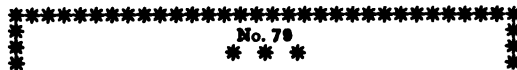
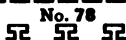
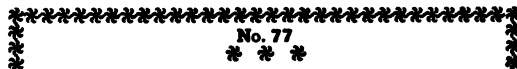
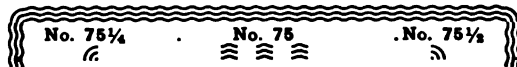
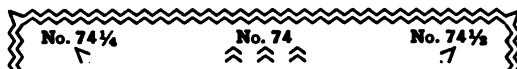
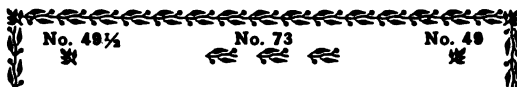
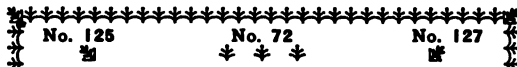

MERGENTHALER LINOTYPE CO.

6 - P O I N T B O R D E R S

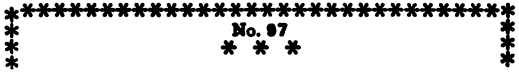
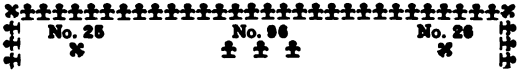
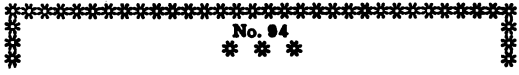
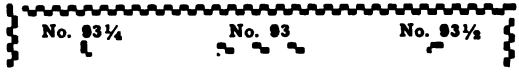
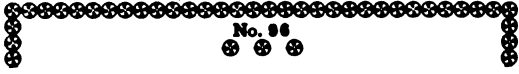
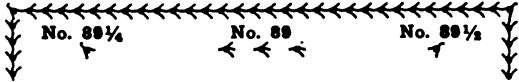
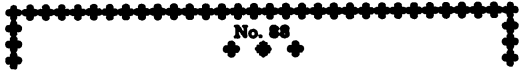
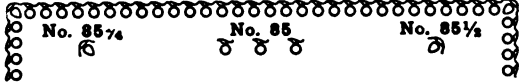
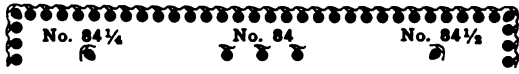

SPECIMENS OF LINOTYPE FACES

6 - P O I N T B O R D E R S

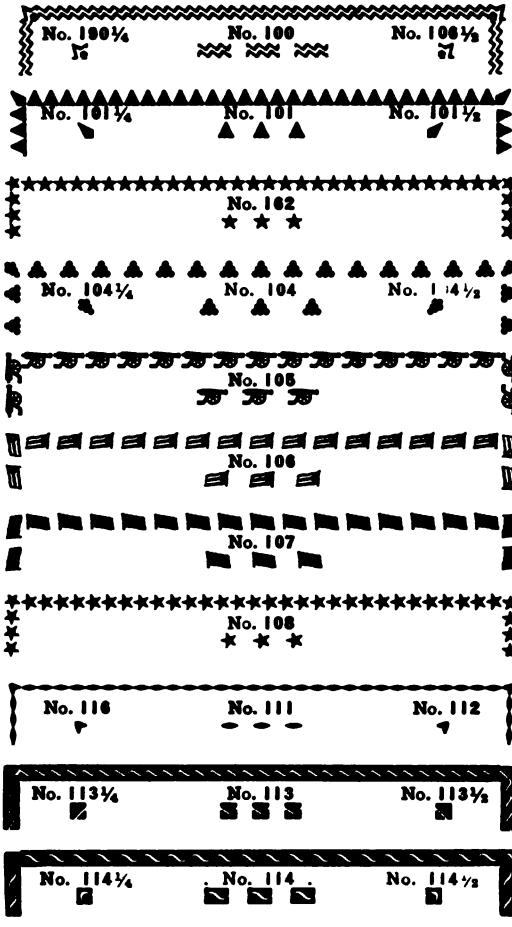

MERGENTHALER LINOTYPE CO.

6 - P O I N T B O R D E R S

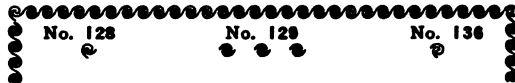
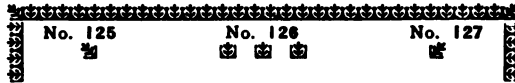
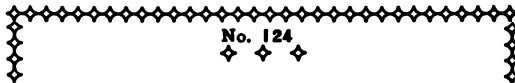
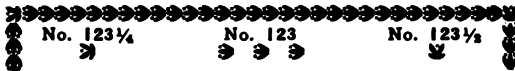
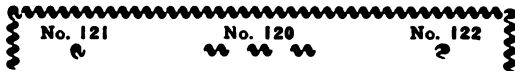

SPECIMENS OF LINOTYPE FACES

8 - P O I N T B O R D E R S

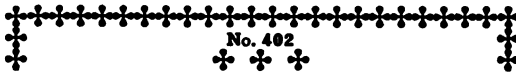

10 - P O I N T B O R D E R S

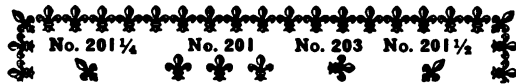

MERGENTHALER LINOTYPE CO.

10 - P O I N T B O R D E R S

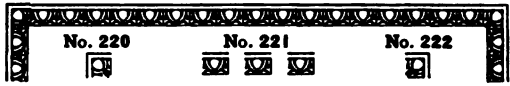
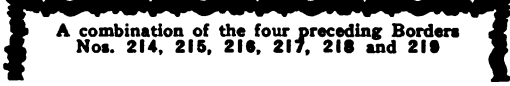
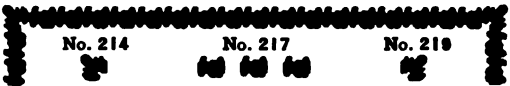
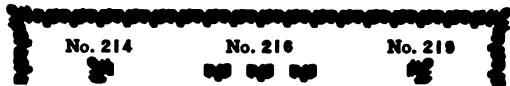

SPECIMENS OF LINOTYPE FACES

10 - P O I N T B O R D E R S



12 - P O I N T B O R D E R S



✓

MERGENTHALER LINOTYPE CO.

DASH QUAD BLOCK
AND MATRIX SLIDES

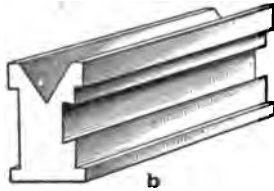

b

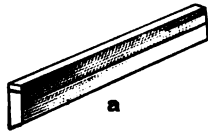

a

THESE cuts show a Dash Quad Block (b) and a removable Matrix Slide (a). The Quad block, containing a matrix slide, is placed in the assembling elevator in the same manner as a line of sorts. The transfer lever is then locked, and any number of dashes may then be produced.

With one Dash Quad Block and a few Matrix Slides (which are interchangeable) the entire cost of brass rules, dashes, etc., may be saved.

These rules are ordinarily made to cast on a 6-Point body, but can be cast on any size from 5½-Point to 12-Point, according to the thickness of the face. They are made any length desired up to 30 ems 12-Point. In ordering please state both the length of face and body desired.

MATRIX SLIDES

No. 102—6-Point

No. 128—6-Point

No. 138—6-Point

No. 157—6-Point

No. 158—6-Point

No. 201—6-Point

SPECIMENS OF LINOTYPE FACES

MATRIX SLIDES

No. 203—6-Point

No. 219—6-Point

No. 251—6-Point

No. 252—6-Point

No. 255—6-Point

No. 258—6-Point

No. 261—7-Point

No. 263—6-Point

No. 266—6-Point

No. 268—6-Point

No. 272—6-Point

No. 274—6-Point

No. 303—6-Point

No. 305—6-Point

No. 307—8-Point

No. 353—6-Point

No. 356—6-Point



MERGENTHALER LINOTYPE CO.

MATRIX SLIDES

No. 401—6-Point	✓
No. 402—6-Point	
No. 403—6-Point	
No. 404—6-Point	✓
No. 405—6-Point	✓
No. 406—6-Point	
No. 407—6-Point	✓
No. 408—6-Point	
No. 409—6-Point	
No. 410—6-Point	
No. 411—6-Point	✓
No. 413—8-Point	✓
No. 415—10-Point	✓
No. 417—12-Point	✓
No. 503—6-Point	
No. 505—6-Point	
No. 508—6-Point	
No. 510—6-Point	
No. 513—6-Point	

SPECIMENS OF LINOTYPE FACES

MATRIX SLIDES

No. 516—6-Point



No. 539 —12-Point



No. 661—6-Point



No. 653—6-Point



No. 735—8-Point



No. 742—6-Point



No. 901



No. 902



No. 904



No. 905—6-Point



No. 909½



No. 907—6-Point



No. 909



No. 918



No. 919½



No. 913



No. 914



MERGENTHALER LINOTYPE CO.

MATRIX SLIDES

No. 919



No. 920



No. 921



No. 923



No. 924



No. 925



No. 926



No. 929



No. 933



No. 939



No. 941



No. 943



No. 944



No. 945



No. 946



No. 949



No. 953



SPECIMENS OF LINOTYPE FACES

MATRIX SLIDES

No. 954



No. 955



No. 956



No. 957



No. 958



No. 959



No. 960



No. 975



No. 980



No. 983



No. 984



No. 987



No. 988



No. 1105



No. 1106



No. 1107



No. 1108



No. 1109



MERGENTHALER LINOTYPE CO.

MATRIX SLIDES

No. 1110

No. 1111

No. 1112

No. 1113

No. 1114

No. 1115

No. 1116

No. 1117

No. 1118

No. 1119

No. 1120

No. 1122

No. 1123

No. 1124

No. 1126

No. 1302—6-Point



No. 1303—6-Point



No. 1304—6-Point



SPECIMENS OF LINOTYPE FACES

MATRIX SLIDES

No. 1307—10-Point



No. 1308—6-Point



No. 1309—6-Point



No. 1310—6-Point



No. 1311—6-Point



No. 1312—6-Point



No. 1315—6-Point



No. 1317—6-Point



No. 1318—6-Point



No. 1321—6-Point



No. 1323—6-Point



No. 1326—6-Point



No. 1328—8-Point



No. 1332—6-Point



No. 1337—6-Point



No. 1351—6-Point



No. 1353—6-Point



MERGENTHALER LINOTYPE CO.

MATRIX SLIDES

No. 1355—8-Point



No. 1357—8-Point



No. 1360—6-Point



No. 1365—6-Point



No. 1371—8-Point



No. 1377—6-Point



No. 1378—6-Point



No. 1382—6-Point



No. 1383—6-Point



No. 1386—6-Point



No. 1406—6-Point



No. 1404—6-Point



No. 1407—6-Point



No. 1409—6-Point



No. 1411—6-Point



No. 1416—6-Point



SPECIMENS OF LINOTYPE FACES

MATRIX SLIDES

No. 1418—6-Point

No. 1419—6-Point

No. 1420—6-Point

No. 1422—6-Point

No. 1423—8-Point

No. 1424—6-Point

No. 1426—6-Point

No. 1428—6-Point

No. 1430—6-Point

No. 1431—6-Point

No. 1432—6-Point

No. 1434—6-Point

No. 1436—6-Point

No. 1438—6-Point

No. 1439—6-Point

No. 1441—6-Point

No. 1451—6-Point

MERGENTHALER LINOTYPE CO.

MATRIX SLIDES

No. 1452—6-Point



No. 1453—6-Point



No. 1455—6-Point

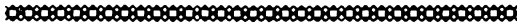

No. 1456—6-Point



No. 1457—6-Point



No. 1458—6-Point



No. 1463—6-Point



No. 1467—6-Point



No. 1468—6-Point



No. 1501—6-Point



No. 1503—6-Point



No. 1509—6-Point



No. 1507—6-Point



No. 1509—6-Point



No. 1512—6-Point



No. 1517—6-Point



No. 1520—6-Point



SPECIMENS OF LINOTYPE FACES

MATRIX SLIDES

No. 1522—6-Point



No. 1523—6-Point



No. 1525—12-Point.



No. 1554—6-Point



No. 1560—6-Point



No. 1558—6-Point



No. 1571—6-Point



No. 1573—6-Point



No. 1574—8-Point



No. 1575—10-Point



No. 1603—10-Point



No. 1604—10-Point



No. 1600—6-Point



No. 1613—6-Point



No. 1610—6-Point



No. 1616—6-Point

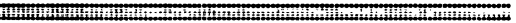

MERGENTHALER LINOTYPE CO.

MATRIX SLIDES

No. 1623—6-Point



No. 1654—10-Point



No. 1660—8-Point



No. 1671—6-Point

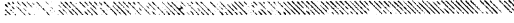

No. 1674—6-Point



No. 1701—6-Point



No. 1706—6-Point



No. 1712—8-Point



No. 1715—6-Point



No. 1710—6-Point



No. 1717—6-Point



No. 1718—6-Point



No. 1719—6-Point



No. 1721—6-Point

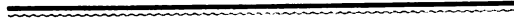

No. 1725—6-Point



No. 1728—6-Point



No. 1751—6-Point



No. 1756—6-Point



SPECIMENS OF LINOTYPE FACES

MATRIX SLIDES

No. 1763—6-Point



No. 1769—6-Point



No. 1773—6-Point



No. 1775—10-Point



No. 1779—10-Point



No. 1777—10-Point



No. 1778—10-Point



No. 1779—6-Point



No. 1881—6-Point



No. 1885—6-Point



No. 1810—6-Point

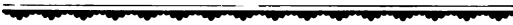

No. 1815—6-Point



No. 1816—6-Point



No. 1810—6-Point



No. 1822—6-Point



No. 1827—6-Point



No. 1881—6-Point



MERGENTHALER LINOTYPE CO.

MATRIX SLIDES

No. 1858—6-Point



No. 1870—6-Point



No. 1878—6-Point



No. 1880—10-Point



ACCENTS USED IN FOREIGN LANGUAGES

The accents below are those in common use in the languages represented and are shown here to assist our customers in selecting the proper characters for doing work in these languages:

BOHEMIAN

Á Ā Ć Ď Ě Ě Ī Ń Ó Ŕ Š Ť Ů Ű Ý Ž
 á ā ć đ ě ě ĩ ń ó ŕ š ť ú ű ý ž

✓ ITALIAN

À È Ì Ò Ù
 à è ì ò ù

BRAZILIAN

À Ā Ç É Ě Ī Ń Ó Ő Ů Û
 á ā ç é ě ĩ ń ó ő ű ü

POLISH

Ą Ć Ę Ł Ó Ś Ź Ż Ń
 ą ć ę ł ó ś ź ż ń

DANISH AND NORWEGIAN

Æ Ø

æ ø

DUTCH

Ŵ Ŷ

ESPERANTO

Ĉ Ĝ Ĥ Ĵ Ŝ Ŭ
 ĉ ĝ ĥ ĵ ŝ ŭ

PORTUGUESE

À É Í Ó Ú Æ Ñ Ç Û
 á é í ó ú ã õ ñ ç ü

SPANISH ✓

À É Í Ó Ú Ñ Ñ
 á é í ó ú ñ ñ

FRENCH

À Á Ê Ë È Ě Ī Î Ï Ò Ù Ů Û Ç
 à á ê ë è ě ĩ î ï ò ù ű ü ç

SWEDISH

Å Ä Ö
 å ä ö

GERMAN

Ä Ö Ü
 ä ö ü

SLAVIC

À Ā Ć Ď Ě Ī Ĺ Ľ Ń Ő Ó Š Ť Ů Ű Ý Ž
 á ā ć đ ě ĩ ľ ľ ń ő ó š ť ú ű ý ž

HUNGARIAN

À É Í Ó Ő Ů Ű Û
 á é í ó ő ő ű ű ü

WELSH ✓ ✓ ✓

À Å Æ Ö Ŵ Ŷ Ŷ
 à å æ ö ŵ ŷ ŷ

LITHUANIAN

À Á Ā Ć Ě È Ě Ī Ĺ Ĺ Ő Ó Ő Ů
 Ů Ů Ů Ž
 á á á ć ě ě ĩ Ĺ Ĺ ő ó ő ű ű ű ž

TYPE FACES WHICH MOST CLOSELY RESEMBLE LINOTYPE FACES

Linotype	Type	Foundry or other source
5-point No. 18.	5-point No. 18.	Miller & Richards.
5-point No. 10 with	No Type.	Remodelled from 5-point
Gothic No. 4.	No Type.	No. 18.
5½-point Bold Face Italic.	6-point Bold Face Italic	Remodelled from 7-point
5½-point No. 1.	No. 120.	Gothic No. 4.
5½-point No. 2.	5½-point No. 4.	Am. Typefounders Co.
5½-point No. 3.	No Type.	Barnhardt Brothers &
5½-point Bold Face No. 1.	6-point Bold Face.	Spindler.
5½-point Bold Face No. 2.	No Type.	Designed for Mergenthaler
5½-point Clarendon No. 1.	No Type.	Linotype Co.
5½-point Bold Face with	5½-point Bold Face.	Designed for Mergenthaler
8-point Ionic.	6-point Bold Face.	Linotype Co.
6-point De Vinne with	Pearl Clarendon.	New York Tribune &
Antique No. 3.	5½-point Bold Face.	Journal.
6-point Antique No. 1.	8-point Ionic.	Barnhardt Brothers &
6-point No. 1.	6-point No. 11.	Spindler.
6-point No. 2.	6-point Antique.	Imported from England.
6-point No. 3.	No Type.	New York Tribune &
6-point No. 12.	No Type.	Journal.
6-point Old Style No. 1.	No Type.	Farmer, Little & Co.
6-point Ronaldson.	6-point No. 12.	Bruce Typefoundry.
6-point German No. 1.	No Type.	Bruce Typefoundry.
6-point German No. 8.	6-point German.	Cut from 8-point No. 1
6-point Clarendon No. 1.	No Type.	Patterns.
6-point Gothic No. 2.	No Type.	Cut from 5½-point Patterns.
6-point Gothic No. 3.	No Type.	Designed for Mergenthaler
6-point Title No. 2.	6-point No. 12.	Linotype Co.
6-point German Bold Face	No Type.	Miller & Richards.
No. 2.	6-point Antique No. 6.	Remodelled from 10-point
6-point Antique No. 2.	6-point Royal Gothic.	Drawings.
6-point Royal Gothic.	No Type.	Remodelled from 10-point
6-point No. 2 with	No Type.	Drawings.
Italic.	6-point No. 12.	Cut from 8-point Patterns.
6-point No. 12 with	6-point Italic No. 52.	Imported from Germany.
Italic.	No Type.	Cut from 5½-point Patterns.
6-point Ronaldson with	6-point No. 11.	Designed for Mergenthaler
Antique No. 1.	No Name Given.	Linotype Co.
6-point De Vinne with	No Name Given.	Redesigned from faces
Antique No. 1.	6-point Jenson Old Style.	already made.
6-point Classic with	No Type.	Miller & Richards.
Italic.	No Type.	Am. Typefounders Co.
6-point Jenson.	No Type.	Remodelled from 10-point
6-point Hebrew.	No Type.	Drawings.
6-point No. 1 Rogers Tabu- lar.	6-point No. 11 and Italic.	Cut from 10-point Patterns.
6-point De Vinne with Italic.	6-point Gothic Italic No. 2.	Bruce Typefoundry.
6-point Gothic Italic No. 4.		Am. Typefounders Co.

TYPE FACES RESEMBLING LINOTYPE FACES.—Continued

Linotype	Type	Foundry or other source
6-point No. 1 with Bold Face No. 2.	No Type. 6-point Bold Face.	Cut from 5½-point Patterns. Barnhardt Brothers & Spindler.
6-point Aldine.	6-point Aldine.	Barnhardt Brothers & Spindler.
6-point No. 28 with Italic. (Corps 6 No. 28 with Italic.)	6-point Series No. 28 and Italic.	Fonderie Turlot, France.
6-point No. 26 Rogers Tabular.	6-point No. 26.	Inland Typefoundry.
7-point Bold Face Italic No. 1.	7-point Bold Face Italic No. 120.	Am. Typefounders Co.
7-point No. 1.	No Type.	Cut from 5½-point Patterns. Designed for Mergenthaler Linotype Co.
7-point No. 2.	No Type.	Designed for Mergenthaler Linotype Co.
7-point No. 3.	No Type.	Miller & Richards.
7-point No. 21.	7-point No. 21.	Cut from 6-point Old Style No. 1 Patterns.
7-point Old Style No. 1.	No Type.	Cut from 6-point Ronaldson Patterns.
7-point Ronaldson.	No Type.	Remodelled from 8-point Gothic No. 3.
7-point Gothic No. 3.	No Type.	Benton & Waldow.
7-point Gothic No. 2.	6-point Lining Gothic.	Connors' Sons Typefoundry.
7-point Doric No. 1.	6-point Doric.	Inland Typefoundry.
7-point Caslon.	7-point Caslon.	Am. Typefounders Co.
7-point Bold Face No. 1.	7-point Bold Face No. 120.	Redesigned from faces already made.
7-point Gothic No. 4.	No Type.	Cut from 10-point Patterns.
7-point Antique No. 1.	No Type.	Cut from 8- and 10-point Patterns.
7-point Title No. 2.	No Type.	Fonderie Turlot, France.
7-point No. 28 with Italic. (Corps 7 No. 28 with Italic.)	7-point Series No. 28 and Italic.	Fonderie Turlot, France.
7-point No. 28 with Egyptienne Serree.	7-point Series No. 28.	Fonderie Turlot, France.
7-point No. 3 with Italic.	7-point Egyptienne Serree.	Designed for Mergenthaler Linotype Co.
8-point No. 1.	No Type.	7-point No. 3 Italic punches used.
8-point No. 2.	No Type.	Cut from 5½-point Patterns. Designed for Mergenthaler Linotype Co.
8-point No. 4.	8-point No. 12.	Barnhardt Brothers & Spindler.
8-point No. 19.	8-point No. 19.	Miller & Richards.
8-point De Vinne.	8-point No. 11.	Bruce Typefoundry.
8-point Scotch.	8-point Scotch Old Style.	Imported from Scotland.
8-point Old Style No. 1.	No Type.	Cut from 10-point Old Style Patterns.
8-point Ronaldson.	No Type.	Cut from 10-point Ronaldson Patterns.
8-point Elzevir.	8-point Elzevir.	Barnhardt Brothers & Spindler.
8-point Hebrew.	8-point Hebrew No. 2.	Am. Typefounders Co.
8-point German No. 1.	8-point German.	New Yorker Staats Zeitung.
8-point German No. 8.	No Type.	Cut from 8-point Patterns.
8-point Ionic No. 1.	8-point Ionic No. 2.	Farmer, Little & Co.
8-point Gothic No. 3.	8-point Gothic.	Type Redesigned.
8-point Clarendon No. 1.	8-point Clarendon.	Type Unknown.
8-point Celtic No. 1.	8-point Celtic.	Bruce Typefoundry.
8-point Antique No. 1.	No Type.	Cut from 10-point Patterns.
8-point Title No. 1.	8-point Cushing Old Style.	Am. Typefounders Co.
8-point Title No. 2.	8-point De Vinne.	Am. Typefounders Co.
8-point German Bold Face No. 2.	8-point German Bold Face.	Imported from Germany.
8-point Antique No. 3.	8-point Antique.	Bruce Typefoundry.
8-point Caslon.	8-point Caslon.	Inland Typefoundry.
8-point Elzevir Gothic.	8-point Elzevir Gothic.	Am. Typefounders Co.
8-point Greek.	8-point Greek (Porson).	Am. Typefounders Co.
8-point Antique No. 1.	No Type.	Cut from 10-point Patterns.

TYPE FACES RESEMBLING LINOTYPE FACES.—Continued

Linotype	Type	Foundry or other source
8-point Ionic with 10-point Clarendon.	8-point Ionic No. 2.	Farmer, Little & Co.
8-point Century Expanded.	8-point Clarendon.	Farmer, Little & Co.
8-point Title Italic No. 2.	8-point Century Expanded.	Am. Typefounders Co.
8-point Ronaldson with Antique No. 1.	8-point De Vinne Italic.	Am. Typefounders Co.
8-point Cheltenham.	No Type.	Cut from 10-point Patterns.
8-point Royal Gothic.	8-point Cheltenham Old Style.	Am. Typefounders Co.
8-point No. 2 with	8-point Royal Gothic.	Am. Typefounders Co.
Bold Face No. 1.	No Type.	Designed for Mergenthaler Linotype Co.
8-point No. 4 with	7-point Bold Face.	Barnhardt Brothers & Spindler.
Italic.	8-point No. 12.	Barnhardt Brothers & Spindler.
8-point Cheltenham with	No Type.	8-point No. 1 Italic used.
Italic.	8-point Cheltenham Old Style.	Am. Typefounders Co.
8-point No. 2 with	No Type.	Designed for Mergenthaler Linotype Co.
10-point Clarendon.	No Type.	Designed for Mergenthaler Linotype Co.
8-point Uniline.	8-point Clarendon No. 1.	Farmer, Little & Co.
8-point Classic with	8-point Cardinal.	Keystone Typefoundry.
Italic.	No Name Given.	Gensch & Heyes, Germany.
8-point De Vinne Condensed.	8-point De Vinne Condensed.	Am. Typefounders Co.
8-point Latin Antique.	8-point Latin Antique.	Inland Typefoundry.
8-point No. 2 with	No Type.	Designed for Mergenthaler Linotype Co.
Condensed Title No. 3.	8-point Condensed No. 1.	Inland Typefoundry.
8-point Cheltenham Bold Face.	8-point Cheltenham Bold Face.	Am. Typefounders Co.
8-point Jenson.	8-point Jenson Old Style.	Am. Typefounders Co.
8-point Aldine.	8-point Aldine.	A. D. Farmer & Son.
8-point No. 1 Rogers Tabu- lar.	No Type.	Cut from Regular 5½-point Patterns.
8-point Uniline with Title No. 1.	8-point Cardinal.	Keystone Typefoundry.
8-point Gothic Italic No. 4.	8-point Cushing Old Style.	Am. Typefounders Co.
8-point Gothic Condensed No. 2.	8-point Gothic Italic No. 2.	Central Typefoundry Branch.
8-point Cambridge with Italic.	8-point Lining Gothic Condensed No. 529.	Am. Typefounders Co.
8-point Admiral.	8-point Old Style No. 20 and Italic.	Bruce Typefoundry.
8-point No. 28 with Italic.	8-point Admiral.	Keystone Typefoundry.
(Corps 8 No. 2 with Italic.)	8-point Series No. 28 and Italic.	Fonderie Turlot, France.
8-point No. 28 with Egyptienne Serree.	8-point Series No. 28.	Fonderie Turlot, France.
8-point Bold Face No. 1.	8-point Egyptienne Serree.	Fonderie Turlot, France.
9-point No. 18 (old alignment).	7-point Bold Face.	Barnhardt Brothers & Spindler.
9-point No. 18 (new alignment).	No Type.	Cut from 10-point No. 3 Patterns.
9-point De Vinne.	No Type.	Cut from 10-point No. 3 Patterns.
9-point Old Style No. 1.	9-point No. 11.	Bruce Typefoundry.
9-point Ronaldson.	No Type.	Cut from 10-point Old Style Patterns.
9-point German No. 2.	No Type.	Cut from 10-point Ronaldson.
9-point German No. 3.	No Type.	Designed for Mergenthaler Linotype Co.
9-point Hebrew.	9-point German.	Imported from Germany.
9-point German Bold Face No. 1.	No Type.	Cut from 8-point Hebrew.
9-point Antique No. 3.	9-point German Bold Face.	Type Unknown.
9-point No. 28 with Italic.	9-point Antique.	Bruce Typefoundry.
(Corps 9 No. 28 with Italic.)	9-point Series No. 28 and Italic.	Fonderie Turlot, France.

TYPE FACES RESEMBLING LINOTYPE FACES.—Continued

Linotype	Type	Foundry or other source
10-point Title Condensed No. 1.	10-point Title No. 125.	Am. Typefounders Co.
10-point Gothic No. 3.	8-point Gothic No. 4.	Am. Typefounders Co.
10-point Antique Condensed.	8-point Antique Condensed No. 122.	Am. Typefounders Co.
10-point No. 1.	10-point No. 19.	Farmer, Little & Co.
10-point No. 13.	10-point No. 13.	A. D. Farmer & Son.
10-point De Vinne.	10-point No. 11.	Bruce Typefoundry.
10-point Scotch.	10-point Scotch Old Style.	Imported from Scotland.
10-point Elzevir.	10-point Elzevir.	Barnhardt Brothers & Spindler.
10-point Caslon.	10-point Caslon.	Inland Typefoundry.
10-point Old Style No. 1.	10-point Old Style No. 3.	MacKellar, Smith & Jordan. (Remodelled.)
10-point Ronaldson.	10-point Ronaldson.	MacKellar. Part of font remodelled.
10-point German No. 2.	No Type.	Designed for Mergenthaler Linotype Co.
10-point German No. 3.	10-point German.	Imported from Germany.
10-point Clarendon No. 1.	8-point Clarendon.	Farmer, Little & Co.
10-point Antique No. 1.	No Type.	Designed for Mergenthaler Linotype Co.
10-point Title No. 2.	No Type.	Cut from 8-point Patterns.
10-point German Bold Face No. 2.	10-point German Bold Face.	Imported from Germany.
10-point Antique No. 3.	10-point Antique.	Miller & Richards.
10-point Elzevir Gothic.	10-point Elzevir Gothic.	Am. Typefounders Co.
10-point Greek.	10-point Porson Greek.	Am. Typefounders Co.
10-point Title No. 1.	10-point Cushing Old Style.	Am. Typefounders Co.
10-point Ionic No. 1.	No Type.	Cut from 8-point Patterns.
10-point Doric No. 1.	No Type.	Cut from 7-point Patterns.
10-point Century Expanded.	10-point Century Expanded.	Am. Typefounders Co.
10-point Bold Face No. 1.	10-point Bold Face.	Barnhardt Brothers & Spindler.
10-point Ronaldson with Antique No. 1.	10-point Ronaldson.	MacKellar, Smith & Jordan. Part of font remodelled.
10-point Cheltenham.	No Type.	Designed for Mergenthaler Linotype Co.
10-point Latin Italic.	10-point Cheltenham Old Style.	Am. Typefounders Co.
10-point No. 6 with Italic.	10-point Latin Italic No. 42.	Am. Typefounders Co.
10-point Bold Face Italic No. 2 with Clarendon No. 1.	10-point No. 4 and Italic.	Barnhardt Brothers & Spindler.
10-point Law Italic.	No Type.	Modelled from 7-point face.
10-point Original Old Style with Italic.	8-point Clarendon.	Farmer, Little & Co.
10-point Berlin Antique.	8-point Law Italic No. 120.	Am. Typefounders Co.
10-point Condensed Title No. 2.	No Type.	Cut from 12-point Patterns.
10-point Antique No. 3 with 12-point Gothic No. 1.	10-point Original Old Style Italic.	A. D. Farmer & Son.
10-point Uniline.	10-point Roman Black Face.	Imported from Germany.
10-point Classic with Italic.	10-point Condensed Title No. 104.	Am. Typefounders Co.
10-point Clarendon No. 1.	10-point Antique.	Miller & Richards.
10-point Title No. 2 with Italic.	No Type.	Cut from 11-point Patterns.
10-point De Vinne Condensed.	10-point Cardinal.	Keystone Typefoundry.
10-point Latin Antique.	10-point Elzevir and Italic No. 2.	Genesch & Heyes, Germany.
10-point Gothic Condensed.	8-point Clarendon No. 1.	Farmer, Little & Co.
10-point Cheltenham with Italic.	No Type.	Cut from 8-point Patterns.
	10-point De Vinne Condensed.	Cut from 8-point Patterns.
	10-point Latin Antique.	Am. Typefounders Co.
	10-point Latin Antique.	Inland Typefoundry.
	10-point Gothic Condensed No. 123.	Am. Typefounders Co.
	12-point Cheltenham Old Style.	Am. Typefounders Co.
	No Type.	Designed for Mergenthaler Linotype Co.

TYPE FACES RESEMBLING LINOTYPE FACES.—Continued

Linotype	Type	Foundry or other source
10-point No. 1 Rogers Tabular	No Type.	Cut from regular 10-point No. 1 Patterns.
10-point Cheltenham Bold Face.	10-point Cheltenham Bold Face.	Am. Typefounders Co.
10-point Jenson.	10-point Jenson Old Style.	Am. Typefounders Co.
10-point Cambridge with Italic.	10-point No. 20 and Italic.	Bruce Typefoundry.
10-point Aldine.	10-point Aldine.	A. D. Farmer & Son.
10-point Uniline with Title No. 1.	10-point Cardinal.	Keystone Typefoundry.
10-point No. 5 with Italic.	10-point Cushing Old Style.	Am. Typefounders Co.
10-point French Old Style with Italic.	10½-point Supreme Court and Italic.	Judd & Detweiler, Washington, D. C.
10-point Bold Face No. 1.	10-point French Old Style and Italic.	Similar to Lanston Face used by McClures', New York.
10-point No. 9 with Italic.	10-point Bold Face.	Barnhard Brothers & Spindler.
10-point Gothic Condensed.	No Type.	Remodelled from 11-point Patterns.
10-point No. 28 with Italic.	10-point Lining Gothic Condensed No. 529.	Am. Typefounders Co.
(Corps 10 No. 28 with Italic.)	10-point Series No. 28 and Italic.	
11-point Antique No. 1.	No Type.	Fonderie Turlot, France.
11-point No. 1.	No Type.	Cut from 10-point No. 1 Patterns.
11-point No. 9.	No Type.	Cut from 10-point Patterns.
11-point De Vinne.	11-point No. 9.	A. D. Farmer & Son.
11-point Scotch.	11-point No. 11.	Bruce Typefoundry.
11-point Old Style No. 1.	11-point Scotch Old Style.	Imported from Scotland.
11-point Ronaldson.	No Type.	Cut from 10-point Old Style No. 1 Patterns.
11-point German No. 3.	No Type.	Cut from 10-point Ronaldson Patterns.
11-point Hebrew.	11-point German.	Imported from Germany.
11-point German Bold Face No. 2.	11-point Hebrew No. 2.	Am. Typefounders Co.
11-point Gothic No. 1.	11-point German Bold Face.	Imported from Germany.
11-point Caslon.	No Type.	Designed for Mergenthaler Linotype Co.
11-point Antique No. 3.	11-point Caslon.	Inland Typefoundry.
11-point Ronaldson with Antique No. 1.	11-point Antique.	Miller & Richards.
11-point Doric No. 2.	No Type.	Cut from 10-point Ronaldson Patterns.
11-point Antique No. 3 with De Vinne Italic.	10-point Doric.	Cut from 10-point Antique No. 1 Patterns.
11-point Sectional Two-letter.	11-point Antique.	From B. H. Tyrrell, New York.
11-point Cambridge with Italic.	11-point No. 11.	Miller & Richards.
11-point No. 9 Plain and Cancelled.	20-point Two-line No. 105.	Bruce Typefoundry.
12-point Gothic No. 1.	11-point No. 20 and Italic.	Bruce Typefoundry.
12-point Law Italic.	11-point No. 9.	A. D. Farmer & Son.
12-point Antique Condensed.	No Type.	Modelled from regular Roman Face.
12-point Antique No. 1.	No Type.	Cut from 11-point Patterns.
12-point Ronaldson No. 1.	No Type.	Am. Typefounders Co.
12-point De Vinne.	No Type.	Cut from 10-point No. 1 Patterns.
12-point Scotch.	10-point Law Italic No. 120.	Cut from 11-point Ronaldson Patterns.
12-point Caslon.	10-point Antique Condensed No. 122.	Bruce Typefoundry.
12-point Typewriter.	No Type.	Imported from Scotland.
12-point Gothic No. 5.	12-point No. 11.	Inland Typefoundry.
12-point Old Style No. 1.	12-point Scotch Old Style.	Am. Typefounders Co.
12-point Antique No. 3.	12-point Caslon.	Am. Typefounders Co.
	12-point Stenograf.	Cut from 10-point Old Style No. 1 Patterns.
	12-point Gothic No. 112.	Miller & Richards.
	No Type.	
	12-point Antique.	

TYPE FACES RESEMBLING LINOTYPE FACES.—Continued

Linotype	Type	Foundry or other source
12-point Condensed Title No. 1.	12-point Condensed Title No. 125.	Am. Typefounders Co.
12-point Elzevir.	No Type.	Cut from 10-point Patterns.
12-point Clarendon No. 1.	No Type.	Cut from 10-point Patterns.
12-point Century Expanded.	12-point Century Expanded.	Am. Typefounders Co.
12-point Bold Face No. 1.	12-point Bold Face.	Barnhardt Brothers & Spindler.
12-point No. 1.	No Type.	Cut from 10-point Patterns.
12-point Ronaldson with Antique No. 1.	No Type.	Cut from 11-point Ronaldson Patterns.
12-point Cheltenham.	12-point Cheltenham Old Style.	Cut from 10-point Antique No. 1 Patterns.
12-point Remington Typewriter.	12-point Remington Standard.	Am. Typefounders Co.
12-point Caslon Text.	12-point Caslon Text.	Inland Typefoundry.
12-point Original Old Style with Italic.	12-point Original Old Style Roman.	A. D. Farmer & Son.
12-point Berlin Antique.	12-point Original Old Style Italic.	Cut from 12-point Patterns.
12-point Condensed Title No. 2.	12-point Roman Black Face.	Imported from Germany.
12-point Cheltenham Bold Face.	12-point Condensed Title No. 104.	Am. Typefounders Co.
12-point Baskerville Condensed.	12-point Cheltenham Bold Face.	Am. Typefounders Co.
12-point Uniline.	12-point Post Condensed.	Am. Typefounders Co.
12-point Gothic No. 5 with Gothic No. 1.	12-point Cardinal.	Keystone Typefoundry.
12-point Classic with Italic.	12-point Gothic No. 112.	Am. Typefounders Co.
12-point De Vinne Outline.	No Type.	Cut from 11-point Patterns.
12-point De Vinne Condensed.	12-point Elzevir and Italic No. 2.	Gensch & Heyes, Germany.
12-point Cheltenham with Italic.	12-point De Vinne Outline.	Keystone Foundry.
12-point Title No. 2.	12-point De Vinne Condensed.	Am. Typefounders Co.
12-point Jenson.	12-point Cheltenham Old Style.	Am. Typefounders Co.
12-point Lining Gothic No. 1.	No Type.	Designed for Mergenthaler Linotype Co.
12-point Century Expanded with 10-point Bold Face No. 1.	12-point Jenson Old Style.	Cut from 8-point Patterns.
12-point Sectional Two-letter.	12-point Lining Gothic No. 55.	Am. Typefounders Co.
12-point Latin Antique.	12-point Century Expanded.	Am. Typefounders Co.
12-point Gothic No. 3.	10-point Bold Face.	Barnhardt Brothers & Spindler.
12-point Gothic Condensed No. 2.	No Type.	Modelled from faces from Toronto <i>Telegraph</i> .
14-point No. 36.	12-point Lining Gothic Condensed No. 529.	Cut from 10-point Patterns.
14-point Original Old Style with Italic.	14-point No. 19.	Cut from 10-point Patterns.
14-point Cheltenham with Italic.	No Type.	Am. Typefounders Co.
14-point Baskerville Condensed.	14-point Cheltenham and Italic.	Bruce Typefoundry.
14-point Gothic Condensed No. 2.	No Type.	Cut from 12-point Patterns.
8-point Egyptienne Serree No. 1 with Normande No. 4.	14-point Lining Gothic Condensed No. 529.	Boston Public Library.
7-point Egyptienne Serree No. 1 with Normande No. 4.	8-point Egyptienne Serree.	Am. Typefounders Co.
	No Type.	Remodelled from 12-point Patterns.
	No Type.	Am. Typefounders Co.
	7-point Egyptienne Serree.	Fonderie Turlot, France.
	No Type.	Designed from Pinel's Drawings.
		Fonderie Turlot, France.
		Designed from Pinel's Drawings.

TYPE FACES RESEMBLING LINOTYPE FACES.—Continued

Linotype	Type	Foundry or other source
9-point Egyptienne Serree No. 1 with Normande No. 4.	9-point Egyptienne Serree. No Type.	Fonderie Turlot, France. Designed from Pinel's Drawings.
6-point No. 28 with Egyptienne Serree.	6-point No. 28.	Fonderie Turlot, France.
10-point No. 28 with Egyptienne Serree.	6-point Egyptienne Serree. 10-point No. 28. 10-point Egyptienne Serree.	Fonderie Turlot, France. Fonderie Turlot, France.
8-point No. 24.	8-point Series No. 24 and Italic.	Fonderie Turlot, France.
9-point No. 24.	9-point Series No. 24 and Italic.	Fonderie Turlot, France.
7-point No. 24.	7-point Series No. 24 and Italic.	Fonderie Turlot, France.
10-point No. 24.	10-point Series No. 24 and Italic.	Fonderie Turlot, France.
8-point No. 28 with Normande No. 4.	8-point Series No. 28. No Type.	Fonderie Turlot, France. Designed from Pinel's Drawings.
7-point Aldine.	No Type.	Cut from 8-point Patterns.
6-point No. 12 with Gothic No. 8.	6-point No. 12. 6-point Gothic.	Miller & Richards. Received from Donnelly & Sons, Chicago, Ill.
9-point De Vinne with 10-point Gothic No. 4.	9-point No. 11. No Type.	Bruce Typefoundry. Cut from 7-point Patterns.
11-point Doric No. 1 with Bold Face Italic No. 4.	10-point (Didot) Doric No. 1. 10-point (Didot) Bold Face Italic.	Received from Gumaelius & Komp, Sweden.
12-point Latin Antique.	No Type.	Cut from 10-point Patterns.
6-point Century Expanded.	6-point Lining Century Expanded.	Am. Typefounders Co.
10-point Berlin Antique with 11-point Gothic No. 1.	10-point Roman Black Face. No Type.	Imported from Germany. Designed for Mergenthaler Linotype Co.
10-point Condensed Title No. 1 with 12-point Antique Condensed.	10-point Title No. 125. 10-point Antique Condensed No. 2.	Am. Typefounders Co. Am. Typefounders Co.
12-point No. 1 Rogers Tabular.	No Type.	Cut from regular 10-point No. 1 Patterns.
5½-point No. 12 Rogers Tabular.	5½-point No. 15.	Bruce Typefoundry.
6-point Gothic Condensed No. 2.	6-point Lining Gothic Condensed No. 529.	Am. Typefounders Co.
8-point Antique No. 1 with Italic.	No Type. No Type.	Cut from 10-point Patterns. Designed from Roman Face.
11-point Century Expanded.	11-point Century Expanded.	Am. Typefounders Co.
8-point Jenson with Italic.	8-point Jenson Old Style. 8-point Jenson Italic.	Am. Typefounders Co. Am. Typefounders Co.
8-point No. 28 with Normande No. 3.	8-point Series No. 28. 8-point Normande No. 2.	Fonderie Turlot, France. Fonderie Turlot, France.

CLASSIFIED INDEX TO SPECIMENS

ONE-LETTER FACES

	Page		Page
Admiral, 8-Point	412	Gothic Elzevir, 10-Point.....	410
Aldine No. 1, 6-Point.....	368	Gothic Royal, 6-Point.....	414
Aldine No. 1, 8-Point.....	370	Gothic Royal, 8-Point.....	415
Aldine No. 1, 10-Point.....	372	Greek, 8-Point	106
Antique No. 1, 7-Point.....	424	Greek, 10-Point	107
Antique No. 1, 8-Point.....	426	Hebrew, 6-Point	102
Antique No. 1, 10-Point.....	428	Hebrew, 8-Point	103
Baskerville Condensed, 12-Point...	446	Hebrew, 9-Point	104
Baskerville Condensed, 14-Point...	448	Hebrew, 11-Point	105
Berlin Antique, 10-Point.....	420	Ionic No. 1, 8-Point.....	334
Berlin Antique, 12-Point.....	422	Ionic No. 1, 10-Point.....	336
Bold Face No. 1, 5½-Point.....	460	Jenson, 6-Point	360
Bold Face No. 1, 8-Point.....	462	Jenson, 8-Point	362
Bold Face No. 1, 10-Point.....	464	Jenson, 10-Point	364
Bold Face No. 1, 12-Point.....	466	Jenson, 12-Point	366
Bold Face Italic No. 1, 7-Point...	468	Latin Antique, 8-Point.....	430
Bold Face No. 1 German, 9-Point...	476	Latin Antique, 10-Point.....	432
Bold Face No. 2 German, 6-Point...	478	Law Italic, 10-Point.....	434
Bold Face No. 2 German, 8-Point...	480	Law Italic, 12-Point.....	436
Bold Face No. 2 German, 10-Point...	482	No. 9, 11-Point.....	38
Bold Face No. 2 German, 11-Point...	484	No. 19, 8-Point.....	50
Caslon Text, 12-Point.....	458	Old Style No. 1, 6-Point.....	60
Celtic No. 1, 8-Point.....	456	Old Style No. 1, 8-Point.....	62
Cheltenham, 8-Point	54	Old Style No. 1, 9-Point.....	64
Cheltenham, 10-Point	56	Old Style No. 1, 10-Point.....	66
Cheltenham, 12-Point	58	Old Style No. 1, 11-Point.....	68
Cheltenham Bold Face, 8-Point...	460	No. 1, 5½-Point	10
Cheltenham Bold Face, 10-Point...	462	No. 1, 6-Point	12
Cheltenham Bold Face, 12-Point...	464	No. 1, 7-Point	14
Clarendon No. 1, 6-Point.....	326	No. 1, 8-Point	16
Clarendon No. 1, 8-Point.....	328	No. 1, 10-Point	18
Clarendon No. 1, 10-Point.....	330	No. 1, 11-Point	20
Clarendon No. 1, 12-Point.....	332	No. 1 German, 6-Point.....	86
Condensed Antique, 10-Point.....	416	No. 1 German, 8-Point.....	88
Condensed Antique, 12-Point.....	418	Remington Typewriter, 12-Point...	439
De Vinne Condensed, 8-Point.....	354	Ronaldson, 6-Point	70
De Vinne Condensed, 10-Point.....	356	Ronaldson, 8-Point	72
De Vinne Condensed, 12-Point.....	358	Ronaldson, 9-Point	74
De Vinne Outline, 12-Point.....	352	Ronaldson, 10-Point	76
Doric No. 1, 7-Point.....	470	Ronaldson, 11-Point	78
Doric No. 1, 10-Point.....	472	Stenograf Typewriter, 12-Point...	438
Doric No. 2, 11-Point.....	474	No. 3, 5½-Point	30
No. 18, 5-Point.....	48	No. 3, 6-Point	32
Elzevir No. 1, 8-Point.....	80	No. 3, 7-Point	34
Elzevir No. 1, 10-Point.....	82	No. 3 German, 6-Point.....	94
Elzevir No. 1, 12-Point.....	84	No. 3 German, 8-Point.....	96
No. 4, 8-Point.....	36	No. 3 German, 10-Point.....	98
Gothic No. 1, 11-Point.....	382	No. 3 German, 11-Point.....	100
Gothic No. 1, 12-Point.....	384	No. 13, 9-Point (Old Alignment)...	42
Gothic No. 2, 7-Point.....	386	No. 13, 9-Point (New Alignment)...	44
Gothic Condensed No. 2, 8-Point...	388	No. 13, 10-Point	46
Gothic Condensed No. 2, 10-Point...	390	Title No. 1, 8-Point.....	338
Gothic Condensed No. 2, 12-Point...	392	Title No. 1, 10-Point.....	340
Gothic Condensed No. 2, 14-Point...	394	Title No. 2, 6-Point.....	342
Gothic No. 3, 8-Point.....	396	Title No. 2, 7-Point.....	344
Gothic No. 3, 10-Point.....	398	Title No. 2, 8-Point.....	346
Gothic No. 4, 7-Point.....	400	Title No. 2, 10-Point.....	348
Gothic Italic No. 4, 6-Point.....	402	Title No. 2, 12-Point.....	350
Gothic Italic No. 4, 8-Point.....	404	Title No. 1 Condensed, 10-Point...	374
Gothic No. 5, 12-Point.....	406	Title No. 1 Condensed, 12-Point...	376
Gothic Elzevir, 8-Point.....	408	Title No. 2 Condensed, 10-Point...	378

ONE-LETTER FACES—(Continued)

	Page		Page
Title No. 2 Condensed, 12-Point....	380	No. 2, 8-Point	28
No. 12, 6-Point	40	No. 2 German, 9-Point.....	90
No. 21, 7-Point	52	No. 2 German, 10-Point.....	92
No. 2, 5½-Point	22	Uniline, 8-Point	440
No. 2, 6-Point	24	Uniline, 10-Point	442
No. 2, 7-Point	26	Uniline, 12-Point	444

TWO-LETTER FACES

Antique No. 3 with De Vinne Italic, 11-Point	514	French Old Style, 10-Point.....	238
Antique No. 3, 10-Point, with 12- Point Gothic No. 1.....	510	Gothic No. 5 with Gothic No. 1, 12-Point	512
Bold Face No. 1, 5½-Point, with 10-Point Clarendon No. 1... ..	498	Gothic No. 3, 8-Point, with 10- Point Clarendon No. 1.....	502
Bold Face No. 1, 5½-Point, with 8-Point Ionic	492	Ionic, 8-Point, with 10-Point Clar- endon No. 1.....	500
Bold Face No. 1 with Bold Face Italic, 5½-Point	488	No. 9, 10-Point	160
Bold Face No. 1 with Bold Face Italic, 7-Point	490	No. 9, 11-Point	162
Bold Face Italic No. 2 with Clar- endon No. 1, 10-Point.....	504	No. 19 with Title No. 1, 8-Point...	174
Cambridge, 8-Point	232	No. 19, 8-Point	172
Cambridge, 10-Point	234	Old Style No 1, 6-Point.....	184
Cambridge, 11-Point	236	Old Style No. 1, 7-Point.....	186
Caslon, 7-Point	254	Old Style No. 1, 8-Point.....	188
Caslon, 8-Point	256	Old Style No. 1, 9-Point.....	190
Caslon, 10-Point	258	Old Style No. 1, 10-Point.....	192
Caslon, 11-Point	260	Old Style No. 1, 11-Point.....	194
Caslon, 12-Point	262	Old Style No. 1, 12-Point.....	196
Century Expanded, 8-Point.....	176	Old Style No. 1 with Antique No. 1, 6-Point	212
Century Expanded, 10-Point.....	178	Old Style No. 1 with Antique No. 1, 8-Point	214
Century Expanded, 12-Point.....	180	Old Style No. 1 with Antique No. 1, 10-Point	216
Century Expanded, 12-Point, with Bold Face No. 1, 10-Point..	182	Old Style No. 1 with Antique No. 1, 11-Point	218
Cheltenham, 8-Point	290	Old Style No. 1 with Antique No. 1, 12-Point	220
Cheltenham, 10-Point	292	No. 1, 5½-Point.....	112
Cheltenham, 12-Point	294	No. 1, 6-Point.....	116
Cheltenham, 14-Point	296	No. 1, 7-Point.....	118
Classic, 6-Point	298	No. 1, 8-Point.....	120
Classic, 8-Point	300	No. 1, 10-Point.....	122
Classic, 10-Point	302	No. 1, 11-Point.....	124
Classic, 12-Point	304	No. 1, 12-Point.....	126
Congressional Roman Plain and Cancelled, 14-Point.....	308	No. 1 with Clarendon No. 1, 5½- Point	110
Congressional Italic Plain and Cancelled, 14-Point.....	310	No. 1 with Bold Face No. 2, 6- Point	114
De Vinne Series, 6-Point.....	264	Original Old Style, 10-Point.....	240
De Vinne Series, 8-Point.....	266	Original Old Style, 12-Point.....	242
De Vinne Series, 9-Point.....	268	Original Old Style, 14-Point.....	244
De Vinne Series, 10-Point.....	270	Ronaldson, 6-Point	198
De Vinne Series, 11-Point.....	272	Ronaldson, 7-Point	200
De Vinne Series, 12-Point.....	274	Ronaldson, 8-Point	202
De Vinne Series with Antique No. 1, 6-Point	276	Ronaldson, 9-Point	204
De Vinne Series with Antique No. 3, 6-Point	278	Ronaldson, 10-Point	206
De Vinne Series with Antique No. 3, 8-Point	280	Ronaldson, 11-Point	208
De Vinne Series with Antique No. 3, 9-Point	282	Ronaldson, 12-Point	210
De Vinne Series with Antique No. 3, 10-Point	284	Ronaldson with Antique No. 1, 6- Point	222
De Vinne Series with Antique No. 3, 11-Point	286	Ronaldson with Antique No. 1, 8- Point	224
De Vinne Series with Antique No. 3, 12-Point	288	Ronaldson with Antique No. 1, 10- Point	226
No. 5, 10-Point.....	156	Ronaldson with Antique No. 1, 11- Point	228
No. 4, 8-Point.....	154	Ronaldson with Antique No. 1, 12- Point	230
		Russian Old Style with Antique No. 1, 10-Point.....	322

TWO-LETTER FACES—(Continued)

	Page		Page
Scotch, 8-Point	246	Title No. 2, 10-Point.....	496
Scotch, 10-Point	248	No. 12, 6-Point	166
Scotch, 11-Point	250	No. 2, 8-Point	150
Scotch, 12-Point	252	No. 2, 8-Point with 10-Point Clar-	
Servian Old Style with Antique		endon	144
No. 1, 10-Point.....	323	No. 2 with Condensed Title No.	
No. 6, 10-Point.....	153	3, 8-Point	142
No. 10 with Gothic No. 4, 5-Point.	164	No. 2 with Gothic No. 3, 8-Point..	140
No. 13, 9-Point	168	No. 2 with Bold Face No. 1, 8-	
No. 13, 10-Point	170	Point	134
No. 26, 14-Point	306	No. 2 with Gothic No. 3, 7-Point..	138
No. 3, 6-Point	152	No. 2 with Bold Face No. 1, 7-	
No. 3 with Bold Face No. 2 Ger-		Point	132
man, 6-Point	312	No. 2, 6-Point	148
No. 3 with Bold Face No. 2 Ger-		No. 2 with Antique No. 2, 6-Point	146
man, 8-Point	314	No. 2 with Gothic No. 3, 6-Point.	136
No. 3 with Bold Face No. 2 Ger-		No. 2 with Bold Face No. 1, 6-	
man, 9-Point	316	Point	130
No. 3 with Bold Face No. 2 Ger-		No. 2 with Bold Face No. 2, 5½-	
man, 10-Point	318	Point	128
No. 3 with Bold Face No. 2 Ger-		Uniline with Title No. 1, 8-Point.	506
man, 11-Point	320	Uniline with Title No. 1, 10-Point.	508
Title No. 2, 8-Point.....	494		

INITIAL LETTERS AND SECTIONAL FIGURES

Gothic No. 1 Two-Line, 20-Point... 520	Gothic No. 4 Sectional Two-Line,
Gothic No. 1 Sectional, 16-Point... 522	12-Point
Gothic No. 1 Sectional, 24-Point... 523	Two-Line, 10-Point
Gothic No. 1 Sectional, 16-Point... 525	Two-Line, 11-Point
Gothic No. 1 Sectional Two-Line	Two-Line, 12-Point
24-Point	Two-Line Sectional, 11-Point.....
525	Two-Line Sectional, 12-Point.....
Gothic No. 4 Sectional, 12-Point... 522	526

ROGERS TABULAR MATRICES

Antique No. 3, 10-Point..... 546	No. 1, 6-Point	531
Bold Face No. 1, 5¼-Point..... 530	No. 1, 8-Point	535
No. 4, High and Low Alignment,	No. 1 Old Style, 7-Point.....	548
8-Point	No. 6, 10-Point	543
536	No. 1, 12-Point	549
Gothic No. 3, 5½-Point..... 529	No. 1 Old Style, 10-Point.....	547
Gothic No. 6, High and Low Align-	No. 1 German, 6-Point.....	534
ment, 8-Point	No. 1 German, 8-Point.....	542
539	No. 1 Old Style, 8-Point.....	538
Ionic No. 1, 8-Point..... 540	No. 6 Gothic, 6-Point.....	532
Ionic No. 4, 8-Point..... 541	No. 12, 10-Point	544
No. 19, High and Low Alignment,	No. 12, 6-Point	533
8-Point	No. 3 Antique, 10-Point.....	546
537		

MISCELLANEOUS

Accents in common use..... 595	Miscellaneous Part Fonts, etc. 533-563
Border Matrices and Matrix	Type resembling Linotype faces 596-602
Slides	Vertical Slug Table Matrices.. 550-551
565-594	

FOR OUR LATEST FACES SEE APPENDIX.



APPENDIX
Showing our Latest Faces

7-POINT ALDINE

[ONE-LETTER]

Lower case alphabet 15.6 ems

THE MOST ANCIENT MATERIALS employed for recording events were bricks, tiles, shells, and tables of stone. The modes of writing on these different substances were various. The tiles and brick were impressed with a stamp when in a soft state; the shells and tablets of stone were etched or graven, the figures or characters being cut in their surface, and in some cases also stained with various colors. It was by the ancient art of stamping that the walls, palaces, and towers of Babylon were covered with hieroglyphics, which have but recently been brought to light from under the immense mounds of Mesopotamia by Layard and other explorers. The patriarch Job, who is supposed to have lived about 2,800 years after the creation, exclaimed, "O THAT MY WORDS WERE NOW WRITTEN! O that they were printed in a book! that they were graven with an iron pen, and hid in the rock forever!" Stung with the unjust accusation of his friends, he desires to record his words that the generations following might see the justice of his cause. The English translation has given the allusion to printing to the text, the original word signifying rather to engrave on a plate, which was doubtless the only printing known to Job. Montfaucon purchased at Rome in 1699 an ancient book entirely composed of lead. It was about four inches long and three inches wide; and not only were the two pieces that formed the cover, and the leaves, six in number, of lead, but also the stick inserted through the rings to hold the leaves together, as well as the hinges and nails. It contained figures of Egyptian idols, and unintelligible writing. China, our ancestor in invention, from remote ages had a kind of stereotyping or printing. It was not, however, as some have supposed, like our printing, phonetic, or the expression of sound, but, like the Egyptian, hieroglyphical; being purely of an artificial structure, denoting every idea by its appropriate sign without any relation to the utterance, and speaking to the eye like the numerical ciphers of the Europeans, which every one understands and utters in his own way. And like most other nations of antiquity, the Chinese were content to remain without alphabetical writing. It is, however, due to the Chinese to add, that they led the way in making good printing-paper. When they invented it does not appear, some affirming that they had the use of it from time immemorial; others that they first discovered it in the second century of the Christian era. Brass, as more durable, was used for inscriptions designed to last the longest, such as treaties, laws, and alliances. Seals, also, were used by the ancients for impressing soft substances. In the British Museum there is a stamp of metal with raised

ABCDEFGHIJKLMNPOQRSTUVWXYZ&

abcdefghijklmnopqrstuvwxyz

1 2 3 4 5 6 7 8 9 0

, . : ; ! ? (|) ' ' - ¢ ¢ ¢ ¢ ¢ ¢ ¢ ¢ ¢ £ \$

@ [] ¼ ½ ¾ ¼ ½ ¾ ¼ ½

8-POINT BOLD FACE NO. 1

[ONE-LETTER]

Lower case alphabet 15.38 cms

THE MOST ANCIENT MATERIALS employed for recording events were bricks, tiles, shells, and tables of stone. The modes of writing on these different substances were various. The tiles and brick were impressed with a stamp when in a soft state; the shells and tablets of stone were etched or graven, the figures or characters being cut in their surface, and in some cases also stained with various colors. It was by the ancient art of stamping that the walls, palaces, and towers of Babylon were covered with hieroglyphics, which have but recently been brought to light from under the immense mounds of Mesopotamia by Layard and other explorers. The patriarch Job, who is supposed to have lived about 2,300 years after the creation, exclaimed, "O THAT MY WORDS WERE NOW WRITTEN! O that they were printed in a book! that they were graven with an iron pen, and hid in the rock forever!" Stung with the unjust accusation of his friends, he desires to record his words that the generations following might see the justice of his cause. The English translation has given the allusion to printing to the text, the original word signifying rather to engrave on a plate, which was doubtless the only printing known to Job. Montfauçon purchased at Rome in 1699 an ancient book entirely composed of lead. It was about four inches long and three inches wide; and not only were the two pieces that formed the cover, and the leaves, six in number, of lead, but also the stick inserted through the rings to hold the leaves together, as well as the hinges and nails. It contained figures of Egyptian idols, and unintelligible writing. China, our ancestor in invention, from remote ages had a kind of stereotyping or printing. It was not, however, as some have supposed, like our printing, phonetic, or the expression of sound, but, like the Egyptian, hieroglyphical; being purely of an artificial structure, denoting every idea by its appropriate sign without any relation to the utterance, and speaking to the eye like the numerical ciphers of the Europeans, which every one understands and utters in his own way. And like most other nations of antiquity, the Chinese were content to remain with-

ABCDEFGHIJKLMNOPQRSTUVWXYZ&

abcdefghijklmnopqrstuvwxyz

1 2 3 4 5 6 7 8 9 0

, . : ; ? (|) * ' ' - . . . ñ ñ ñ ñ ñ ñ œ ð £ \$
 @ [] ½ ¼ ¾ ¼ ¾ ¾ ¾

7-POINT NO. 3 WITH ITALIC

[TWO-LETTER]

Lower case alphabet 14.56 ems

THE MOST ANCIENT MATERIALS employed for recording events were bricks, tiles, shells, and tables of stone. *The modes of writing on these different substances were various.* The tiles and brick were impressed with a stamp when in a soft state; the shells and tablets of stone were etched or graven, the figures or characters being cut in their surface, and in some cases also stained with various colors. It was by the ancient art of stamping that the walls, palaces, and towers of Babylon were covered with hieroglyphics, which have but recently been brought to light from under the immense mounds of Mesopotamia by Layard and other explorers. The patriarch Job, who is supposed to have lived about twenty-three hundred years after the creation, exclaimed, *O THAT MY WORDS WERE NOW WRITTEN! O that they were printed in a book! that they were graven with an iron pen, and hid in the rock forever!* Stung with the unjust accusation of his friends, he desires to record his words that the generations following might see the justice of his cause. The English translation has given the allusion to printing to the text, the original word signifying rather to engrave on a plate, which was doubtless the only printing known to Job. Montfaucon purchased at Rome in sixteen ninety-nine an ancient book entirely composed of lead. It was about four inches long and three inches wide; and not only were the two pieces that formed the cover, and the leaves, six in number, of lead, but also the stick inserted through the rings to hold the leaves together, as well as the hinges and nails. It contained figures of Egyptian idols, and unintelligible writing. China, our ancestor in invention, from remote ages had a kind of stereotyping or printing. It was not, however, as some have supposed, like our printing, phonetic, or the expression of sound, but, like the Egyptian, hieroglyphical; being purely of an artificial structure, denoting every idea by its appropriate sign without any relation to the utterance, and speaking to the eye like the numerical ciphers of the Europeans, which every one understands and utters in his own way. And like most other nations of antiquity, the Chinese were content to remain without alphabetical writing. It is, however, due to the Chinese to add, that they led the way in making good printing-paper. When they invented it does not appear, some affirming that they had the use of it from time immemorial; others that they first discovered it in the second century of the Christian era. Brass, as more durable, was used for inscriptions designed to last the longest, such as treaties, laws, and alliances. Seals, also, were used by the ancients for impressing soft substances. In the British Museum there is a stamp of metal with raised letters. On the back of it is a ring, enabling the owner to wear it as a signet; his name, Caius Julius Cæcilius

ABCDEF GHIJKL MNOPQRST UVWXYZ &
 ABCDEF GHIJKL MNOPQRST UVWXYZ &
 abcdefghijklmnopqrstuvwxyz
 abcdefghijklmnopqrstuvwxyz
 . . . ; ! ? - . . . ñ ñ ñ ñ ñ
 . . . ; ! ? - . . . ñ ñ ñ ñ ñ

6-POINT NO. 12 WITH GOTHIC NO. 8

[TWO-LETTER]

Lower case alphabet 14.7 ems

THE MOST ANCIENT MATERIALS used for recording events were bricks, tiles, shells, and tables of stone. The modes of writing on these different substances were various. The tiles and brick were impressed with a stamp when in a soft state, the shells and tablets of stone were etched or graven, the figures or characters being cut in their surface, and in some cases also stained with various colors. It was by the ancient art of stamping that the walls, palaces, and towers of Babylon were covered with hieroglyphics, which have but recently been brought to light from under the immense mounds of Mesopotamia by Layard and other explorers. The patriarch Job, who is supposed to have lived about 2,300 years after the creation, exclaimed, O THAT MY WORDS WERE NOW WRITTEN! O that they were printed in a book! that they were graven with an iron pen, and hid in the rock forever! Stung with the unjust accusation of his friends, he desires to record his words that the generations following might see the justice of his cause. The English translation has given the allusion to printing to the text, the original word signifying rather to engrave on a plate, which was doubtless the only printing known to Job. Montfaucon purchased at Rome in 1699 an ancient book entirely composed of lead. It was about four inches long and three inches wide, and not only were the two pieces that formed the cover, and the leaves, six in number, of lead, but also the stick inserted through the rings to hold the leaves together, as well as the hinges and nails. It contained figures of Egyptian idols, and unintelligible writing. China, our ancestor in invention, from remote ages had a kind of stereotyping or printing. It was not, however, as some have supposed, like our printing, phonetic, or the expression of sound, but, like the Egyptian, hieroglyphical, being purely of an artificial structure, denoting every idea by its appropriate sign without any relation to the utterance, and speaking to the eye like the numerical ciphers of the Europeans, which every one understands and utters in his own way. And like most other nations of antiquity, the Chinese were content to remain without alphabetical writing. It is, however, due to the Chinese to add, that they led the way in making good printing-paper. When they invented it does not appear, some affirming that they had the use of it from time immemorial, others that they first discovered it in the second century of the Christian era. Brass, as more durable, was used for inscriptions designed to last the longest, such as treaties, laws, and alliances. Seals, also, were used by the ancients for impressing soft substances. In the British Museum there is a stamp of metal with raised letters. On the back of it is a ring, enabling the owner to wear it as a signet. His name, Caius Julius Caecilius Hermias, being engraved in reversed letters upon it. This seal of Hermias was intended for stamping parchment with ink, as is shown by the fact that the roughness of the surface below the letters unfits it for stamping any soft substance into which it would sink, as into wax. If rubbed with printing ink and pressed upon paper, it prints very well. Thus the seed of this noble art was among the Romans. With a block of wood covered with raised letters, they might have printed a page, as well as a single name. But they were suffered to grope their way from age to age blindfolded to the art of which they had the clue. They almost grasped the great discovery, unconscious of the prize. Quintilian, speaking of the education of youth, says, When the boy has begun to trace the forms of the letters,

ABCDEF GHIJKLMNOPQRSTU VWXYZ&
ABCDEF GHIJKLMNOPQRSTU VWXYZ&
abc defghijklmnopqrstuvwxy z
abc defghijklmnopqrstuvwxy z
1 2 3 4 5 6 7 8 9 0
1 2 3 4 5 6 7 8 9 0
: : ! -
: : ! -

11-POINT NO. 9, PLAIN AND CANCELLED

[TWO-LETTER]

Lower case alphabet 11.96 ems

The most ancient materials employed for recording events were bricks, tiles, shells, and tables of stone. The modes of writing on these different substances were various. The tiles and brick were impressed with a stamp when in a soft state; the shells and tablets of stone were etched or graven, the figures or characters being cut in their surface, and in some cases also stained with various colors. It was by the ancient art of stamping that the walls, palaces, and towers of Babylon were covered with hieroglyphics, which have but recently been brought to light from under the immense mounds of Mesopotamia by Layard and other explorers. The patriarch Job, who is supposed to have lived about 2,300 years after the creation, exclaimed, "O THAT MY WORDS WERE NOW WRITTEN! O that they were printed in a book! that they were graven with an iron pen, and hid in the rock forever!" Stung with the unjust accusation of his friends, he desires to record his words that the generations following might see the justice of his cause. The English translation has given the allusion to printing to the text, the original word signifying rather to engrave on a plate, which was doubtless the only printing known to Job. Montfaucon purchased at Rome in 1699 an ancient book entirely composed of lead. It was about four inches long and three inches wide;

ABCDEFGHIJKLMN OPQRSTUVWXYZ

~~ABCDEFGHIJKLMN OPQRSTUVWXYZ~~

abcdefghijklmnopqrstuvwxy z

~~abcdefghijklmnopqrstuvwxy z~~

1 2 3 4 5 6 7 8 9 0

~~1 2 3 4 5 6 7 8 9 0~~

fi fl ff ffi ffl

~~fi fl ff ffi ffl~~

8-POINT (CORPS 8) EGYPTIENNE SERREE WITH NORMANDE

NO. 4

[TWO-LETTER]

WIDTH OF 8-POINT LOWER CASE ALPHABET

<i>Linotype System</i>	14.2	8-point ems
<i>French Didot System</i>	13.5	8-point ems
<i>French Didot System</i>	8.97	12-point ems

THE MOST ANCIENT MATERIALS employed for recording events were bricks, tiles, shells, and tables of stone. The modes of writing on these different substances were various. The tiles and brick were impressed with a stamp when in a soft state; the shells and tablets of stone were etched or graven, the figures or characters being cut in their surface, and in some cases also stained with various colors. It was by the ancient art of stamping that the walls, palaces, and towers of Babylon were covered with hieroglyphics, which have but recently been brought to light from under the immense mounds of Mesopotamia by Layard and other explorers. The patriarch Job, who is supposed to have lived about 2,300 years after the creation, exclaimed, "O THAT MY WORDS WERE NOW WRITTEN! O that they were printed in a book! that they were graven with an iron pen, and hid in the rock forever!" Stung with the unjust accusation of his friends, he desires to record his words that the generations following might see the justice of his cause. The English translation has given the allusion to printing to the text, the original word signifying rather to engrave on a plate, which was doubtless the only printing known to Job. Montfauçon purchased at Rome in 1699 an ancient book entirely composed of lead. It was about four inches long and three inches wide; and not only were the two pieces that formed the cover, and the leaves, six in number, of lead, but also the stick inserted through the rings to hold the leaves together, as well as the hinges and nails. It contained figures of Egyptian idols, and unintelligible writing. China, our ancestor in invention, from remote ages had a kind of stereotyping or printing. It was not, however, as some have supposed, like our printing, phonetic, or the

ABCDEFGHIJKLMN OPQRST UVWXYZ &
 ABCDEFGHIJKLMN OPQRST UVWXYZ &

abcdefghijklmnopqrstuvwxy
 abcdefghijklmnopqrstuvwxyz

1 2 3 4 5 6 7 8 9 0
 1 2 3 4 5 6 7 8 9 0

. . . ; ! ? (|) * - - - . . . ñ ñ ñ ñ ñ æ œ ð £ \$
 . . . ; ! ? (|) * - - - . . . ñ ñ ñ ñ ñ æ œ ð £ \$
 @ [] 1/8 1/4 3/8 1/2 5/8 3/4 7/8
 @ [] 3/8 1/2 5/8 3/4 7/8

7-POINT (CORPS 7) NO. 28 WITH ITALIC AND SMALL CAPS

[TWO-LETTER]

WIDTH OF 7-POINT LOWER CASE ALPHABET

<i>Linotype System</i>	16.11	7-point ems
<i>French Didot System</i>	15.21	7-point ems
<i>French Didot System</i>	8.88	12-point ems

THE MOST ANCIENT MATERIALS used for recording events were bricks, tiles, shells, and tables of stone. *The modes of writing on these different substances were various.* The tiles and brick were impressed with a stamp when in a soft state; the shells and tablets of stone were etched or graven, the figures or characters being cut in their surface, and in some cases also stained with various colors. It was by the ancient art of stamping that the walls, palaces, and towers of Babylon were covered with hieroglyphics, which have but recently been brought to light from under the immense mounds of Mesopotamia by Layard and other explorers. The patriarch Job, who is supposed to have lived about 2,300 years after the creation, exclaimed, "O THAT MY WORDS WERE NOW WRITTEN! *O that they were printed in a book! that they were graven with an iron pen, and hid in the rock forever!*" Stung with the unjust accusation of his friends, he desires to record his words that the generations following might see the justice of his cause. The English translation has given the allusion to printing to the text, the original word signifying rather to engrave on a plate, which was doubtless the only printing known to Job. Montfauçon purchased at Rome in 1699 an ancient book entirely composed of lead. It was about four inches long and three inches wide; and not only were the two pieces that formed the cover, and the leaves, six in number, of lead, but also the stick inserted through the rings to hold the leaves together, as well as the hinges and nails. It contained figures of Egyptian idols, and unintelligible writing. China, our ancestor in invention, from remote ages had a kind of stereotyping or printing. It was not, however, as some have supposed, like our printing, phonetic, or the expression of sound, but, like the Egyptian, hieroglyphical; being purely of an artificial structure, denoting every idea by its appropriate sign without any relation to the utterance, and speaking to the eye like the numerical ciphers of the Europeans, which every one understands and utters in his own way. And like most other nations of antiquity, the Chinese were content to remain without alphabetical writing. It is, however, due to the Chinese to add, that they led the way in making good printing-paper. When they invented it does not appear, some affirming that they had the use of it from time

ABCDEFGHIJKLMNOPQRSTUVWXYZ&
 ABCDEFGHIJKLMNOPQRSTUVWXYZ&
 ABCDEFGHIJKLMNOPQRSTUVWXYZ&
 abcdefghijklmnopqrstuvwxyz
 abcdefghijklmnopqrstuvwxyz
 1 2 3 4 5 6 7 8 9 0
 1 2 3 4 5 6 7 8 9 0
 ? () — — — — —
 ? () — — — — —
 @ [] ¼ ½ ¾ ¼ ½ ¾ ¼

8-POINT (CORPS 8) NO. 28 WITH ITALIC AND SMALL CAPS

[TWO-LETTER]

Lower case alphabet 15.52 ems

THE MOST ANCIENT MATERIALS employed for recording events were bricks, tiles, shells, and tables of stone. *The modes of writing on these different substances were various.* The tiles and bricks were impressed with a stamp when in a soft state; the shells and tablets of stone were etched or graven, the figures or characters being cut in their surface, and in some cases also stained with various colors. It was by the ancient art of stamping that the walls, palaces, and towers of Babylon were covered with hieroglyphics, which have but recently been brought to light from under the immense mounds of Mesopotamia by Layard and other explorers. The patriarch Job, who is supposed to have lived about 2,300 years after the creation, exclaimed, "O THAT MY WORDS WERE NOW WRITTEN! *O that they were printed in a book! that they were graven with an iron pen, and hid in the rock forever!*" Stung with the unjust accusation of his friends, he desires to record his words that the generations following might see the justice of his cause. The English translation has given the allusion to printing to the text, the original word signifying rather to engrave on a plate, which was doubtless the only printing known to Job. Montfaucon purchased at Rome in 1699 an ancient book entirely composed of lead. It was about four inches long and three inches wide; and not only were the two pieces that formed the cover, and the leaves, six in number, of lead, but also the stick inserted through the rings to hold the leaves together, as well as the hinges and nails. It contained figures of Egyptian idols, and unintelligible writing. China, our ancestor in invention, from remote ages had a kind of stereotyping or printing. It was not, however, as some have supposed, like our printing, phonetic, or the expression of sound, but, like the Egyptian, hieroglyphical; being purely of an artificial structure, denoting every idea by its appro-

ABCDEFGHIJKLMNPOQRSTUVWXYZ&

ABCDEFGHIJKLMNPOQRSTUVWXYZ&

ABCDEFGHIJKLMNPOQRSTUVWXYZ&

abcdefghijklmnpqrstuvwxyz

abcdefghijklmnpqrstuvwxyz

1 2 3 4 5 6 7 8 9 0

1 2 3 4 5 6 7 8 9 0

, . : ; ! ? (|) * ' ' - — . . . fi fl ff ml ml æ œ th £ \$

, . : ; ! ? (|) * ' ' - — . . . fl fl ff fl fl æ œ th £ \$

@ [] ¼ ½ ¾ ⅓ ⅔ ⅕ ⅖ ⅗

9-POINT (CORPS 9) NO. 28 WITH ITALIC AND SMALL CAPS
[TWO-LETTER]

WIDTH OF 9-POINT LOWER CASE ALPHABET

<i>Linotype System</i>	15.12	9-point ems
<i>French Didot System</i>	14.27	9-point ems
<i>French Didot System</i>	10.7	12-point ems

THE MOST ANCIENT MATERIALS employed for recording events were bricks, tiles, shells, and tables of stone. *The modes of writing on these different substances were various.* The tiles and brick were impressed with a stamp when in a soft state; the shells and tablets of stone were etched or graven, the figures or characters being cut in their surface, and in some cases also stained with various colors. It was by the ancient art of stamping that the walls, palaces, and towers of Babylon were covered with hieroglyphics, which have but recently been brought to light from under the immense mounds of Mesopotamia by Layard and other explorers. The patriarch Job, who is supposed to have lived about 2,300 years after the creation, exclaimed, "O THAT MY WORDS WERE NOW WRITTEN! *O that they were printed in a book! that they were graven with an iron pen, and hid in the rock forever!*" Stung with the unjust accusation of his friends, he desires to record his words that the generations following might see the justice of his cause. The English translation has given the allusion to printing to the text, the original word signifying rather to engrave on a plate, which was doubtless the only printing known to Job. Montfauçon purchased at Rome in 1699 an ancient book entirely composed of lead. It was about four inches long and three inches wide; and not only were the two pieces that formed the cover, and the leaves, six in number, of lead, but also the stick inserted through the rings to hold the leaves together, as well as the hinges and nails. It

ABCDEFGHIJKLMN OPQRSTUVWXYZ&
 ABCDEFGHIJKLMN OPQRSTUVWXYZ&

ABCDEFGHIJKLMN OPQRSTUVWXYZ&

abcdefghijklmnopqrstuvwxy z

abcdefghijklmnopqrstuvwxy z

1 2 3 4 5 6 7 8 9 0

1 2 3 4 5 6 7 8 9 0

.. : ; ? ! (|) ' " - - . . . fi ff m m \$ £
 .. : ; ? ! (|) ' " * - - . . . fi ff ff fi ff \$ £
 1/8 1/4 3/8 1/2 5/8 3/4 7/8 lb @ []

10-POINT (CORPS 10) NO. 28 WITH ITALIC AND SMALL CAPS

[TWO-LETTER]

WIDTH OF 10-POINT LOWER CASE ALPHABET

<i>Linotype System</i>	14.28	10-point ems
<i>French Didot System</i>	13.47	10-point ems
<i>French Didot System</i>	11.23	12-point ems

THE MOST ANCIENT MATERIALS used for recording events were bricks, tiles, shells, and tables of stone. *The modes of writing on these different substances were various.* The tiles and brick were impressed with a stamp when in a soft state; the shells and tablets of stone were etched or graven, the figures or characters being cut in their surface, and in some cases also stained with various colors. It was by the ancient art of stamping that the walls, palaces, and towers of Babylon were covered with hieroglyphics, which have but recently been brought to light from under the immense mounds of Mesopotamia by Layard and other explorers. The patriarch Job, who is supposed to have lived about 2,300 years after the creation, exclaimed, "O THAT MY WORDS WERE NOW WRITTEN! *O that they were printed in a book! that they were graven with an iron pen, and hid in the rock forever!*" Stung with the unjust accusation of his friends, he desires to record his words that the generations following might see the justice of his cause. The English translation has given the allusion to printing to the text, the original word signifying rather to engrave on a plate, doubtless the only printing known to Job. Montfauçon purchased at Rome in 1699 an ancient book entirely com-

ABCDEFGHIJKLMN OPQRSTUVWXYZ &
 ABCDEFGHIJKLMN OPQRSTUVWXYZ &

ABCDEFGHIJKLMN OPQRSTUVWXYZ &

abcdefghijklmn opqrstuvwxyz

abcdefghijklmn opqrstuvwxyz

1 2 3 4 5 6 7 8 9 0

1 2 3 4 5 6 7 8 9 0

, . : ; ? ! (|) ' ' * - — . . . fi fl ff m m lb £ \$

, . : ; ? ! (|) ' ' * - — . . . fi fl ff m m lb £ \$

@ æ œ [] 1 1/8 1/4 3/8 1/2 5/8 3/4 7/8

7-POINT (CORPS 7) NO. 28 WITH EGYPTIENNE SERREE

[TWO-LETTER]

WIDTH OF 7-POINT LOWER CASE ALPHABET

<i>Linotype System</i>	16.12	<i>7-point ems</i>
<i>French Didot System</i>	15.2	<i>7-point ems</i>
<i>French Didot System</i>	8.87	<i>12-point ems</i>

THE MOST ANCIENT MATERIALS employed for recording events were bricks, tiles, shells, and tables of stone. The modes of writing on these different substances were various. The tiles and brick were impressed with a stamp when in a soft state; the shells and tablets of stone were etched or graven, the figures or characters being cut in their surface, and in some cases also stained with various colors. It was by the ancient art of stamping that the walls, palaces, and towers of Babylon were covered with hieroglyphics, which have but recently been brought to light from under the immense mounds of Mesopotamia by Layard and other explorers. The patriarch Job, who is supposed to have lived about 2,300 years after the creation, exclaimed, "O THAT MY WORDS WERE NOW WRITTEN! O that they were printed in a book! that they were graven with an iron pen, and hid in the rock forever!" Stung with the unjust accusation of his friends, he desires to record his words that the generations following might see the justice of his cause. The English translation has given the allusion to printing to the text, the original word signifying rather to engrave on a plate, which was doubtless the only printing known to Job. Montfauçon purchased at Rome in 1699 an ancient book entirely composed of lead. It was about four inches long and three inches wide; and not only were the two pieces that formed the cover, and the leaves, six in number, of lead, but also the stick inserted through the rings to hold the leaves together, as well as the hinges and nails. It contained figures of Egyptian idols, and unintelligible writing. China, our ancestor in invention, from remote ages had a kind of stereotyping or printing. It was not, however, as some have supposed, like our printing, phonetic, or the expression of sound, but, like the Egyptian, hieroglyphical; being purely of an artificial structure, denoting every idea by its appropriate sign without any relation to the utterance, and speaking to the eye like the numerical ciphers of the Europeans, which every one understands and utters in his own way. And like most other nations of antiquity, the Chinese were content to remain without alphabetical writing. It is, however, due to the Chinese to add, that they led the way in making good printing-paper. When they invented it does not appear, some

ABCDEFGHIJKLMNORSTUVWXYZ&
 ABCDEFGHIJKLMNORSTUVWXYZ&
 abcdefghijklmnopqrstuvwxyz
 abcdefghijklmnopqrstuvwxyz

1	2	3	4	5	6	7	8	9	0	fl	fl	fl	fl	æ	œ	lb	£	§
1	2	3	4	5	6	7	8	9	0	fl	fl	fl	fl	æ	œ	lb	£	§
@	[]	¼	¼	¾	½	¾	¾	¾									
@	[]	¼	¼	¾	½	¾	¾	¾									

9-POINT (CORPS 9) NO. 28 WITH EGYPTIENNE SERREE

[TWO-LETTER]

WIDTH OF 9-POINT LOWER CASE ALPHABET

<i>Linotype System</i>	14.34	9-point ems
<i>French Didot System</i>	13.54	9-point ems
<i>French Didot System</i>	10.16	12-point ems

THE MOST ANCIENT MATERIALS employed for recording events were bricks, tiles, shells, and tables of stone. **The modes of writing on these different substances were various.** The tiles and brick were impressed with a stamp when in a soft state; the shells and tablets of stone were etched or graven, the figures or characters being cut in their surface, and in some cases also stained with various colors. It was by the ancient art of stamping that the walls, palaces, and towers of Babylon were covered with hieroglyphics, which have but recently been brought to light from under the immense mounds of Mesopotamia by Layard and other explorers. The patriarch Job, who is supposed to have lived about 2,300 years after the creation, exclaimed, **"O THAT MY WORDS WERE NOW WRITTEN! O that they were printed in a book! that they were graven with an iron pen, and hid in the rock forever!"** Stung with the unjust accusation of his friends, he desires to record his words that the generations following might see the justice of his cause. The English translation has given the allusion to printing to the text, the original word signifying rather to engrave on a plate, which was doubtless the only printing known to Job. Montfauçon purchased at Rome in 1699 an ancient book entirely composed of lead. It was about four inches long and three inches wide; and not only were the two pieces that formed the cover, and the leaves, six in number, of lead, but also the stick inserted through the rings to hold the leaves together, as well as the hinges and nails. It contained figures of Egyptian idols,

**ABCDEFGHIJKLMNOPQRSTUVWXYZ&
ABCDEFGHIJKLMNOPQRSTUVWXYZ&**

abcdefghijklmnopqrstuvwxyz

abcdefghijklmnopqrstuvwxyz

1 2 3 4 5 6 7 8 9 0

1 2 3 4 5 6 7 8 9 0

., : ; ? ! (|) ' ' * - — ñ ñ ñ ñ ñ \$ £
., : ; ? ! (|) ' ' * - — ñ ñ ñ ñ ñ \$ £

1/8 1/4 3/8 1/2 5/8 3/4 7/8 lb @ []

8-POINT (CORPS 8) NO. 24 WITH ITALIC AND SMALL CAPS

[TWO-LETTER]

WIDTH OF 8-POINT LOWER CASE ALPHABET		
<i>Linotype System</i>	13.9	8-point ems
<i>French Didot System</i>	14.9	8-point ems
<i>French Didot System</i>	9.2	12-point ems

THE MOST ANCIENT MATERIALS employed for recording events were bricks, tiles, shells, and tables of stone. *The modes of writing on these different substances were various.* The tiles and brick were impressed with a stamp when in a soft state; the shells and tablets of stone were etched or graven, the figures or characters being cut in their surface, and in some cases also stained with various colors. It was by the ancient art of stamping that the walls, palaces, and towers of Babylon were covered with hieroglyphics, which have but recently been brought to light from under the immense mounds of Mesopotamia by Layard and other explorers. The patriarch Job, who is supposed to have lived about 2,300 years after the creation, exclaimed, "O THAT MY WORDS WERE NOW WRITTEN! *O that they were printed in a book! that they were graven with an iron pen, and hid in the rock forever!*" Stung with the unjust accusation of his friends, he desires to record his words that the generations following might see the justice of his cause. The English translation has given the allusion to printing to the text, the original word signifying rather to engrave on a plate, which was doubtless the only printing known to Job. Montfauçon purchased at Rome in 1699 an ancient book entirely composed of lead. It was about four inches long and three inches wide; and not only were the two pieces that formed the cover, and the leaves, six in number, of lead, but also the stick inserted through the rings to hold the leaves together, as well as the hinges and nails. It contained figures of Egyptian idols, and unintelligible writing. China, our ancestor in invention, from remote ages had a kind of stereotyping or printing. It was not, however, as some have supposed, like our printing, phonetic, or the expression of sound, but, like the Egyptian, hieroglyphical; being purely of an artificial structure, denoting every idea by its appropriate sign

ABCDEFGHIJKLMN OPQRSTUVWXYZ&
 ABCDEFGHIJKLMN OPQRSTUVWXYZ&

ABCDEFGHIJKLMN OPQRSTUVWXYZ
 abcdefghijklmnopqrstuvwxyz
 abcdefghijklmnopqrstuvwxyz

1 2 3 4 5 6 7 8 9 0
 1 2 3 4 5 6 7 8 9 0

. . . ; ! ? (|) * ' ' ' - _ : :: Æ Æ Æ Æ Æ Æ æ œ ð £ \$
 . . . ; ! ? (|) * ' ' ' - _ : :: Æ Æ Æ Æ Æ Æ æ œ ð £ \$
 @ [] ¼ ½ ¾ ½ ¾ ¾ ¾



UNIVERSITY OF MICHIGAN

DEC 14 1908

UNIVERSITY OF MICHIGAN
3 9015 07790 0408

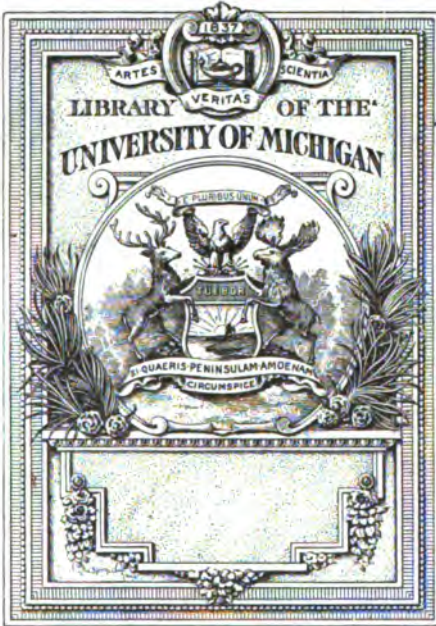

THE GIFT OF
W. C. Hollands

