This is a reproduction of a library book that was digitized by Google as part of an ongoing effort to preserve the information in books and make it universally accessible.

Google™ books

<http://books.google.com>



ISEN
BOOK
PES

UNIVERSITY OF
ILLINOIS LIBRARY
AT URBANA-CHAMPAIGN
FEB 19 1966

UNIVERSITY OF
ILLINOIS LIBRARY
AT URBANA-CHAMPAIGN
1974

A BOOK OF TYPES

BORDERS, ORNAMENTS
BRASS RULE, PRINTING MATERIALS AND
THE LIKE FOR PRINTERDOM

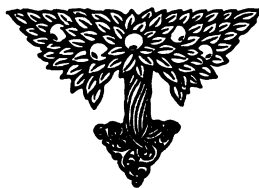

1909

HANSEN'S SUPERIOR QUALITY
ESTABLISHED 1872

THE
H. C. HANSEN TYPE FOUNDRY

190-192 CONGRESS STREET, BOSTON, MASS.

48 CENTRE STREET, NEW YORK CITY

Copyright, 1908, by H. C. Hansen



Congress Street

COMPLETE TYPE FOUNDRY
 Telephone 2703 Main
 Cable Address - Hansen Boston

- H. C. HANSEN, Proprietor and General Manager
- ALFRED HANSEN, Manager



NEW YORK BRANCH HOUSE
 48 Centre Street

9655.24
H196
1909

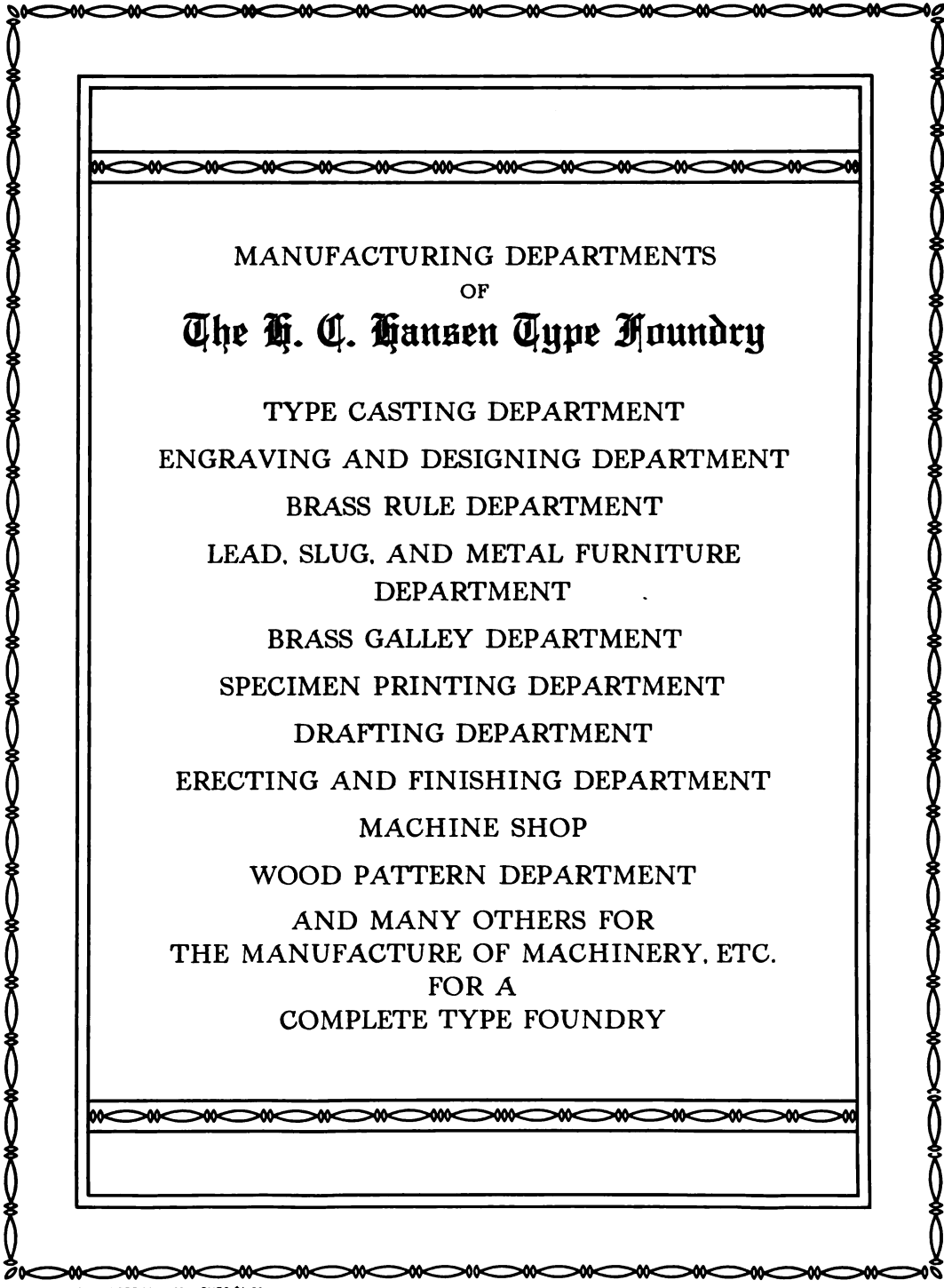

MANUFACTURING DEPARTMENTS
OF
The H. Q. Hansen Type Foundry

TYPE CASTING DEPARTMENT
ENGRAVING AND DESIGNING DEPARTMENT
BRASS RULE DEPARTMENT
LEAD, SLUG, AND METAL FURNITURE
DEPARTMENT
BRASS GALLEY DEPARTMENT
SPECIMEN PRINTING DEPARTMENT
DRAFTING DEPARTMENT
ERECTING AND FINISHING DEPARTMENT
MACHINE SHOP
WOOD PATTERN DEPARTMENT
AND MANY OTHERS FOR
THE MANUFACTURE OF MACHINERY, ETC.
FOR A
COMPLETE TYPE FOUNDRY

8-POINT ROYAL BORDER. 80 INCHES \$1.50

Handwritten notes on the left margin, including the word "Page" and other illegible characters.



HIGHEST AWARD TO H. C. HANSEN FOR THE MANUFACTURE OF
 PRINTERS' MATERIALS AND MACHINERY
 1887





Award a Silver Medal to
H. C. Hansen, *for improvements in casting type and various products.*

Alfred Bicknell



Henry ...
Walter T. Rockwell

HIGHEST AWARD TO H. C. HANSEN FOR EXCELLENCE OF TYPE PRODUCTS
 WELL CONFIRMING THE SUPERIOR QUALITY
 1895



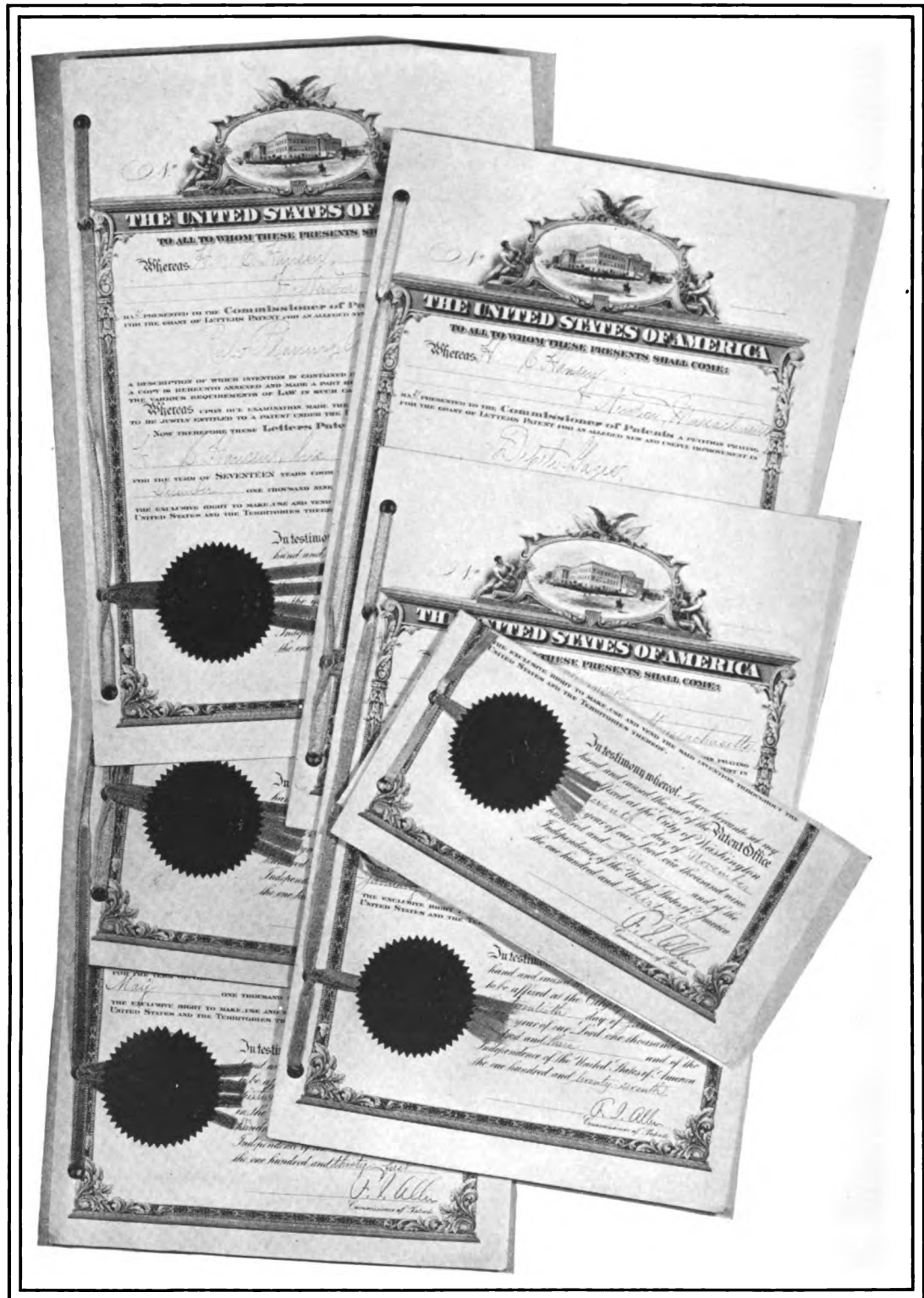

THE ABOVE IS A REPRODUCTION OF A FEW ORIGINAL COPIES OF U. S. PATENTS GRANTED TO MR. H. C. HANSEN. THEY REPRESENT INVENTIONS ON SPECIAL MACHINERY, SUCH AS TYPE CASTING MACHINES, BRASS RULE MACHINES, LEAD AND SLUG MACHINES, TYPE FACES, AND INTRICATE MACHINERY FOR THE ACCURATE MANUFACTURE OF TYPE

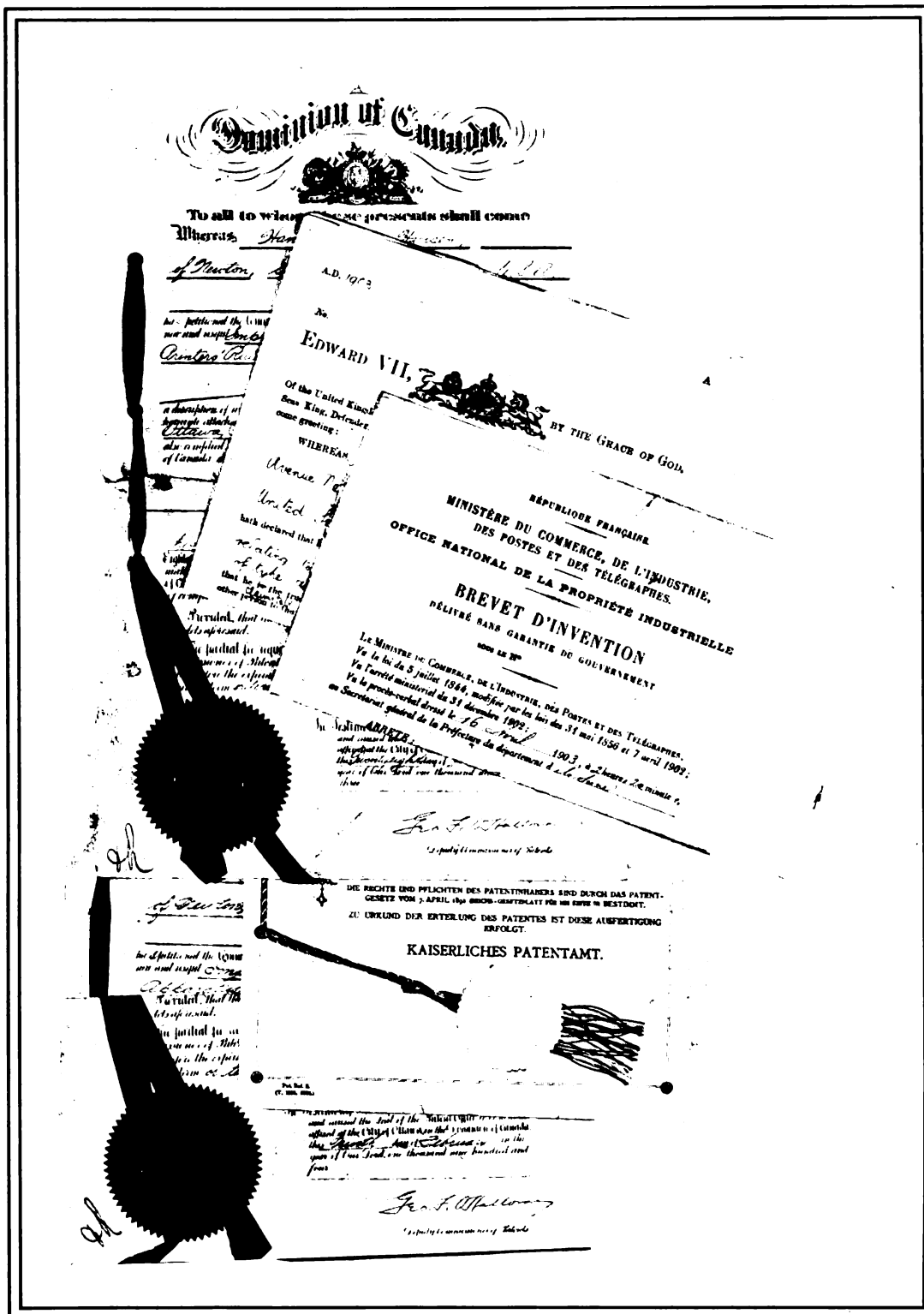

THE ABOVE IS A FAC-SIMILE OF ORIGINAL COPIES OF PATENTS GRANTED TO MR. H. C. HANSEN IN FOREIGN COUNTRIES. THEY REPRESENT INVENTIONS ON THE MOST IMPORTANT MACHINERY FOR THE TYPE INDUSTRY



H. C. HANSEN

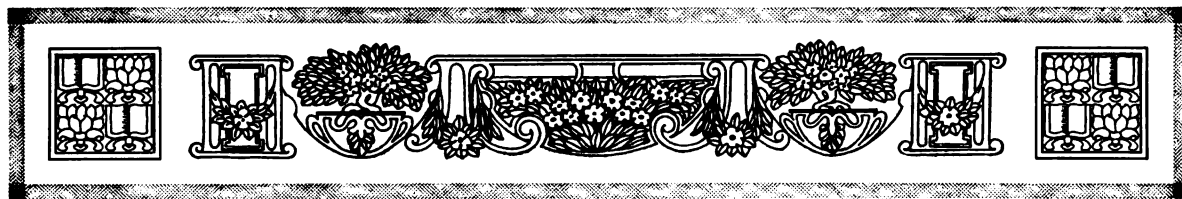

PREFACE AND HISTORY

THE equipment or "plant" of a type foundry consists of hundreds of thousands of moulds, machines, tools and appliances. Because of the utmost accuracy required in the products, it takes a long time, great skill and large capital to equip the plant, as only ordinary machinery, tools and appliances can be purchased, all those required for the finer work having to be designed and made especially for their various purposes. Producing the equipment of a type foundry has, invariably, been accomplished only by ardent and high skilled work, and, almost invariably, only through the succeeding skill of several generations, and through various stages and changes of ownership have type foundries become successful and first-class.

The histories of many well known type foundries in Europe and in this country make interesting reading for printers, type founders, and the public in general. They teach particularly that the type founding art is the basis for the typographical art, which, in turn, is essential to the growth and expansion of all other industries. The history of this, The H. C. Hansen Type Foundry, is in many respects different from that of any other, as its success has all been accomplished by one person without assistance of combinations, but through his persistent labor and skill. It can therefore, be best explained by giving a short description of his life and labors.

Mr. H. C. Hansen was born October sixteenth, 1845, in a small town in the southern part of Norway. His grandfather was the owner and operator of flour mills and farms. His grandfather on his mother's side was superintendent of iron works, and was in possession of the secret of producing wrought iron from cast iron (the well known Norway iron). He has been able to collect the history of his ancestors for about three hundred years back, and found them to have been of considerable prominence in the community in which they lived. His father purchased an estate, including river and waterfalls, and erected thereon, in the year 1851, mills operated by water power. Mr. Hansen, in his sixth year, got his first knowledge of mechanical engineering. It was especially interesting to him to learn that one piece of iron could be cut with another piece of iron in the shape of a cold chisel. During childhood he applied all his spare time to making miniature mills of various kinds and other articles for the amusement of himself and playmates. As a young man he became tolerably efficient in every trade known to him at that time, such as blacksmithing, carpentering, painting, wheelwright, tailoring, shoe-making, glazing, bridge building, stone and brick laying, lock and clock making and farming. His sports were mostly boating, fishing and gunning.

He graduated from the Technology at Horton, in 1866, and went abroad to gain further knowledge, remaining some time in each of the following countries, Denmark, Germany and England, engaging in various mechanical industries, such as engine and ship building, boiler making and the making of cylinder printing presses. Arriving in Boston, January 11, 1868, he entered

the employ of the Dickinson Type Foundry, through the medium of an advertisement in the Boston Herald. He remained in the employ of the Dickinson Type Foundry until after the big Boston fire, November 9, 1872, engaged principally in the making of type, brass rules, matrices, leads, slugs, metal furniture, etc. Whatever branch of type making he was directed to do was always executed to a perfection, and no salesman in the office or any of the customers ever found his work defective.

When in the employ of the Dickinson Type Foundry he made the column rules, head rules, dashes, etc., furnished for the first issue of the Boston Globe. The fire of November 9th consumed all of the Dickinson Type Foundry's plant with the exception of the punches, matrices and moulds which were kept in safes, but they were considerably damaged. The machinery, tools and other devices were destroyed, and it became necessary for the re-establishment of that foundry to purchase the best obtainable, but it was not up to the standard of construction to conform with Mr. Hansen's conception of what could and should be accomplished in the way of improved and labor saving machinery and devices. It was owing to these and similar circumstances that Mr. Hansen formed the bold resolution to establish a Type Foundry of his own, relying entirely on his own resources and ability. The only devices in his possession at that time were a two-foot measuring rule and a limited capital.

His first act in beginning was the designing, drafting and constructing of machinery, etc. for making brass rule, circles, ovals, leads, slugs, metal furniture and other articles which were not easily obtained from any manufacturer in Boston. By constant work from early in the morning until late at night, Mr. Hansen was able to fill orders by the end of the year 1872. His customers were so well pleased with his goods that at every opportunity when any of their printer friends wanted anything in his line they referred them to Mr. Hansen. To this date when inventive genius is needed, many manufacturers send their inquiries to The H. C. Hansen Type Foundry.

In the year 1875, for want of space, he moved his foundry from 24½ Exchange Street, to 26 Hawley Street, and added to his plant type machines, moulds and matrices for casting quads and spaces to the old standard of bodies, as each type foundry made type to their own irregular standards. The Marder-Luce Type Foundry, of Chicago, was the first to adopt the point system standards, and Mr. Hansen made spaces and quads to the point standards, and was the first one in New England adopting the point standard body sizes.

Among his first, largest and best constant customers may be mentioned Thomas Todd, Rand, Avery & Co., Rand-Avery Supply Co., Rockwell & Churchill Co., A. Mudge & Son, L. Barta, Wright & Potter Printing Co., Sampson, Murdock & Co., J. S. Cushing & Co., Frank Wood, F. H. Gilson, Ginn & Co., C. H. Simonds & Co., Perry, Mason & Co., C. H. Heintzman, E. B. Stillings, Samuel Usher, and the Boston Newspapers, as they, with many other first-class houses were seeking for new designs and new methods in printing, this afforded Mr. Hansen great opportunity to gain knowledge of the printers' wants and enabled him to furnish goods and articles that could not be obtained from any other firm.

Each department in the type foundry requires special expert help, such as designers and engravers in the punch cutting departments; fitters and battery men in the fitting departments; casters and adjusters in the type casting departments; dressers, kerners, setters, rubbers and pagers in the type finishing departments; dividers of fonts: labelers and packers of type in the fonting departments; mould makers, tool makers and machinists in the machine shops; casters and

finishers in the lead, slug and metal furniture departments; rule makers and finishers in the brass rule departments; compositors and pressmen in the specimen printing departments; draftsmen, pattern and cabinet makers in the drafting and wood-working departments; salesmen, shippers, bookkeepers, collectors, typewriters and stenographers in the warerooms and offices. Mr. Hansen is an expert in all the trades and professions with the exception of the last mentioned. He can execute or give directions, when occasion requires, in any or all of these branches. Whenever his customers have asked his advice in any mechanical difficulty he has been able and willing to impart the needed instructions, and many inventors have saved or made money by receiving his impartial opinion.

Experienced workmen in type making were for many years not to be hired except by taking them from some other type foundry, which was against Mr. Hansen's principles to do, and he never hired any men while they were in the employ of any other foundry. His method has been to select the most intelligent young men from other occupations, and, with his instruction, they have become the best workmen in type making. His employees have been most sought for by others, and many of the best type makers with his competitors are men who received their first and principal instructions from Mr. Hansen, but he has retained the choice men for his own foundry. Several of his men have been with him from twenty to more than thirty years, and he has the most expert help employed in any type foundry.

Among his first inventions for the benefit of the printing industry was making steel cutting dies for use on the printing press, round and square brass corners, the blocking of regular borders, circles, ovals and cutting dies in metal, the irregular waved and nicked line brass rule borders, and the making of music type from brass. Not the least important is the making of type metal. Mr. Hansen has made it a special study to compound the most durable metal from copper, tin, lead and antimony, these being the only metals of any practical value in the composition of type metal, and he has been successful in producing metal type of the highest grade.

Among his numerous inventions may be mentioned one of recent years most important to the type founding and typographical arts. It enables the type founder to produce fonts of type to perfect height and with less labor than by the old method of filing matrices to height by hand. It consists of very sensitive and accurately designed and constructed instruments and machines, which he patented, in the year 1903, in this country and Europe. Besides in his own foundry, the same are in use in the largest independent type foundry in the West, and also in one of the foremost type foundries in Paris, France, to whom he has furnished instruments and machines and granted license to operate. Mr. Hansen has designed and constructed his own type casting machines, type moulds, type finishing machinery, tools and devices, machinery, moulds, etc. for the making of leads, brass rules, and all other articles necessary for the manufacture of type in all its branches; he has improved and simplified everything; designed numerous faces for type and borders. Of his inventions in machines for the trade may be mentioned the Hansen Perforating Machine, Hansen Complete Mitering Machine, Rule Curving Machine and the Hansen Complete Lead and Rule Cutter, all of which have proved superior to all other makes.

Taking great interest in the advancement of all industries, he visited the Centennial Exposition at Philadelphia, 1876, Columbian Exposition at Chicago, 1893, and the Louisiana Purchase Exposition at St. Louis, 1904, and most of the various industrial and mechanical fairs in New England and New York. He has been a constant observer and student of the rebuilding of Boston, and no new enterprise, be it large or small, within his reach, escapes his notice.

Before the establishment of the Type Foundry Trust in 1892, there were many independent type foundries in this country of which only four are remaining. It was the pride of Boston that it had five, as follows: The Dickinson Type Foundry, The Boston Type Foundry, The New England Type Foundry, Curtis & Mitchell Type Foundry and The H. C. Hansen Type Foundry. The Dickinson and Boston Foundries were taken in the trust; the New England and Curtis & Mitchell Foundries dissolved, it is supposed, for lack of skill; the only one now remaining doing all its manufacturing in Boston is The H. C. Hansen Type Foundry.

When Mr. Hansen first entered a type foundry and began making type he started in that trade, not as beginners usually do, without any practical knowledge, but he began with theoretical and practical knowledge as a mechanical engineer, a great mathematician and a student of improvements and inventions, and, being blessed with good health and strength, he applied his energies and knowledge to the upbuilding of the type foundry and the making of type.

With forty-one years' practical experience in type making credited to Mr. H. C. Hansen, to which his well equipped, high standard type foundry bears evidence, may it not be justly claimed by The H. C. Hansen Type Foundry that it has the most expert type founder living as its general manager and proprietor?

In mentioning the above facts for the first time, in the biography of H. C. Hansen, we wish to conclude with the great importance of having such a head to build up this, The H. C. Hansen Type Foundry, so that it is now an undisputed fact that this Type Foundry has all possibilities to continue for generations to come, keeping its standard at the highest point.

In its manufacturing departments, Mr. Hansen has a son, L. A. Hansen, who has already served several years under his supervision. Another son, H. Alfred Hansen, now manager of The H. C. Hansen Type Foundry, after receiving a mechanical training, starting in the year 1897, began in the machine shop under Mr. H. C. Hansen's instruction, working as an apprentice in the blacksmith department, forging various tools and later building type moulds, type machines, and other machinery for the foundry. He also went through the general working of lead and slug, brass rule and matrix departments, and all other departments. Afterward he entered as a salesman, and later in the office in his present position. At this date he keeps in touch with all the manufacturing departments and many inventions have been brought about by his knowledge of mechanics and the training received from his father. He has brought about the establishment of a New York branch and agencies in many leading cities in the United States.

Complete printing offices have been shipped from our Boston office to San Francisco and Hansen Type is prevailing in the Northwest, being shipped from our St. Paul agency. Shipments of Hansen Type are now going broadcast to all parts of the world.

Previous to this there has been no opportunity to place before those interested in the printing office and publishers a fair representation of this type foundry, illustrated in the form of a catalog, and we hope that this book will be carefully preserved and referred to. There are many items of importance that could not be completed in time to be included in this book. Evidence of our position in the high rank of Type Founding is, we believe, well disclosed in this book. The patronage of our printer friends has made all this possible, and it is to them we acknowledge herein our gratitude. Their hearty support in the future will enable us to progress, which will be to our mutual advantage. This Type Foundry is absolutely independent and is not connected with, or controlled by, any combination or trust. Criticisms sent in to the Boston manager will be appreciated. Untrue reports have been made, by competitors and historians, relative to this foundry, but we believe we are now defended by the facts mentioned above as well as by this complete catalog.

INDEX TO TYPE, BORDERS, ORNAMENTS, BRASS RULE, Etc.

- ACCENTS, Job and Body Type 42-44
 Accents, Piece 44
 Ad. and Job Borders 184, 185, 189
 Ad. Corners, Hansen's 183
 Aladdin Ornaments 205
 Aleppo Borders and Ornaments 195
 Alfred Initials 215
 Antique No. 31 96, 161
 Arancio Borders 211
 Arrow Pointers 182
 Automobile Ornaments 208
- BALLOT SIGNS 167
 Barrister Italic 55
 Bean Pots 208
 Berkshire Ornaments 262-277, 375
 Beveled Quotations and Quads 256, 257, 378
 Bird Ornaments 205
 Black Text 98
 Boldface No. 16 99
 Boldface No. 150, Lining 98
- Borders and Bands
 Ad. and Job 184, 185, 189
 Aleppo 195
 Arancio 211
 Bellman 200
 Buffalo 190, 202
 Buffalo Outline 202
 Commercial 185
 Crinklesquare 188
 Croix 197
 Crystal 213
 Egg-and-Dart 213
 Fleur-de-lis 196
 Grapevine 206
 Holly 201
 Imperial Borders and Bands 209
 Laurel 193
 Maltese Cross 188
 Marguerite 192
 Multiplex 186, 187
 Nos. 502, 503 190
 No. 504 210
 No. 1450 375
 Panel 208
 Reliance 188
 Royal 3, 375
 Runion 203, 210
 Siam 210
 Square Unit 213
 Sylph 198, 199
 Sylph Outline 198, 199
 Sylph Stippled 200
 Twig 188
 Twin Buffalo 190
 Uneda 210
 University 212
 Waverley Bands 200
 Zion 168
- Boston Bean Pots 208
 Boston Gothic 118, 119
 Boston Italic 376
 Braces, Hansen's Handy 168
 Braces and Half Braces, Brass 240
 Brackets 167
 Brass and Copper Thin Spaces 261
 Brass Centre Pieces 254
 Brass Circles and Ovals 242-247
 Brass Clamps, Curved Lines 241
 Brass Corners
 Brazed 254
 Combination 253
 Dash 241
- Diagonal 252
 Mortised 253
 Slotted 255
 Solid 249-251
 Square 226
- Brass Dashes 231, 239
 Brass Flourishes 241
 Brass Fractional Marks 254
 Brass Leaders, Labor-saving 231
 Brass Leads and Slugs 237
 Brass Rule Border Designs 248
 Brass Rules 217-230
 Advertising 231
 Art 227
 Column 232
 Dash 231
 Halftone 228
 Head 232
 High Art 229, 230
 Initial 255
 Labor-saving 236, 237
 Linotype Column 232
 Mitered, Labor-saving 233-237
 New 225, 226
 New Designs 235
 Perforating 231
 Popular 234
 Scoring 231
 Brass Trade Signs 231
- Buffalo Series 76-78, 158, 159
 Buffalo Condensed 80, 81
 Buffalo Italic 79
 Buffalo Outline 82, 83, 155
- CALENDAR and Commercial Figures . 170-179
 Calendars, Perpetual 169
 Cambridge 126, 127, 164
 Campaign Ornaments 191
 Card Gothic 144
 Card Gothic No. 2 145
 Card Gothic No. 3 146, 147
 Card Pips 167
 Card Roman 148
 Card Text 143
 Caslon Fullface, Lining 32-45
 Caslon Fullface Italic, Lining 45
 Caslon O. S. No. 1 29, 37
 Caslon O. S. No. 2 30, 31, 46, 47
 Caslon O. S. Italic No. 2 48
 Circles and Ovals, Brass 242-247
 Commercial Borders 185
 Commercial Signs 166
 Commonwealth 136
 Congress 131
 Copperplate Roman 153
 Corner Quads, Brass 241
 Corner Quads, Metal 227
 Crawford 70-72
 Crawford Italic 73
 Crinklesquare Borders 188
 Croix Borders 197
 Crystal Borders 213
 Cursive Script 98
 Cutting Dies, Steel 238
 Cutting Rule, Steel 231
- DASHES, Brass 231, 239
 Dashes, Fancy 167
 Dashes, Lining Job 167
 Date Lines, Electrotyped 180
 De Vinne No. 3, Lining 84, 85, 156
 De Vinne Condensed No. 3, Lining 86, 157
 De Vinne Ext. Condensed No. 3, Lining 90, 91
 De Vinne Extended 88, 89
 De Vinne Italic No. 3, Lining 87
- EGG-AND-DART Borders 213
 Estimates for Job Offices 17
 Extended Lining Gothic 123
- FERNCROFT Initials 214
 Figures, Calendar and Commercial 170-179
 Figures, Tabular 178, 179
 Figures, Inferior 167
 Figures, Superior 167
 Fists 167
 Flags 191
 Fleur-de-lis Borders and Ornaments 196
 Floral Ornaments 206
 Florette Ornaments 206
 Fourteenth Century 36
- Fractions
 De Vinne 166
 Gothic 166
 Miscellaneous 166
 Modern 166
 Old Style 166
 Piece 167
- French Old Style Italic No. 3, Lining 52
 French Old Style No. 3, Lining 35, 52, 53
 Furniture, Metal 258, 260
- GERMAN Boldface 38
 German Text 39
 German, 10-Point 169
 Gothic No. 1 104
 Gothic Condensed No. 2 107
 Gothic Condensed No. 3 108, 109
 Gothic Condensed No. 4 125
 Gothic Condensed No. 5 124
 Gothic Condensed No. 400 110-112
 Gothic Extra Condensed 106
 Gothic No. 6 114, 115
 Gothic No. 18, Lining 122
 Gothic Italic 120, 121
 Grapevine Borders 206
- HALFTONE Shadowtype 380, 381
 Hampton 74
 Hansen O. S. No. 30, Lining 92, 93, 165
 Hansen O. S. Italic No. 30, Lining 94
 Hansen O. S. No. 40, Lining 97, 163
 Hansen Ornaments 195
 Hansen Vertical Script 149
 Heading 100
 Heading Outline 100
 Holly Borders 201
 Holly Ornaments 201, 283
 Howland 138
 Hub Ornaments 185
 Hunnewell Italic 58
 Hunnewell Series 34, 56-61
- IMPERIAL Borders and Bands 209
 Imprints 168
 Inclined Gothic 113
 Inferior Figures 167
 Initial Rules, Brass 255
 Initials
 Alfred 215
 Berkshire . 263, 267, 269, 274, 275, 276, 277, 375
 Ferncroft 214
 Hansen O. S. 214
 Sylph 216
- LABOR-SAVING Brass Rule 236, 237
 Lace Ornaments 211
 Lafayette Text 140-142
 Laurel Border 193

THE H. C. HANSEN TYPE FOUNDRY

INDEX TO TYPE, BORDERS, ORNAMENTS, BRASS RULE, Etc.—Continued

Leaders, Brass	231	Automobile	208	Roman No. 8	25
Leaders, Lining	40-41	Berkshire	262-277, 375	Roman No. 14	25
Leads and Slugs	261	Bird	205	Roman No. 40 Italic, Lining	28
Lining Boldface No. 150	98	Boston Bean Pots	208	Roman No. 40, Lining	22, 23, 28
Lining Caslon Fullface	32, 45	Buffalo and Buffalo Outline	192	Ronaldson No. 112, Lining	21
Lining Caslon Fullface Italic	45	Buffalo Italic	191	Ronaldson Extended No. 3, Lining	37
Lining De Vinne No. 3	84, 85, 156	Buffaloes	185	Round Corners, Metal	183
Lining De Vinne Condensed No. 3	86, 157	Campaign	191	Royal Border	3, 375
Lining De Vinne Extended	88, 89	Candlestick	167	Runion Borders	203, 210
Lining De Vinne Extra Condensed	90, 91	Flags	191	Russian Characters	168
Lining De Vinne Italic No. 3	87	Fleur-de-lis	196		
Lining French O. S. Italic No. 3	52	Floral	206	SANTA CLAUS Cuts	277
Lining French O. S. No. 3	35, 52, 53	Florette	206	Siam Border	210
Lining Gothic	105	Hansen	195	Slugs and Leads	261
Lining Gothic No. 18	122	Holly	201, 283	Society Emblems	284
Lining Hansen O. S. Italic No. 30	94	Hub	185	Spear Indicators	183
Lining Hansen O. S. No. 30	92, 93, 165	Lace	211	Square Unit Borders	213
Lining Hansen O. S. No. 40	97-163	Muller	208	Standard Type Measures	168
Lining Latin Antique No. 3	101, 162	Palisade	208	Stars, Black, Outline and Shaded	167
Lining Latin Condensed No. 3	95	Printers' Joys	207	Steel Cutting Dies	238
Lining Modern Antique No. 3	102, 103	Santa Claus	277	Steel Plate Gothic	139
Lining National Roman	26, 27	Stratford O. S.	191	Stenograf	54
Lining National Roman Italic	28	Studio	204	Stippled Gothic	132, 133
Lining Old Style Italic No. 110	28	Swastika and Swastika Outline	194	Stratford O. S.	66-69, 160
Lining Old Style Italic No. 112	28	Swastika Rimmed	213	Stratford O. S. Ornaments	191
Lining Old Style No. 110	20	Symphony	278-281	Studio Ornaments	204
Lining Roman No. 40	22, 23	Tailpiece	206	Superior and Inferior Figures	167
Lining Roman No. 40 Italic	28	Teddy Bear	196	Swastika and Swastika Outline Ornaments	194
Lining Ronaldson Extended No. 3	37	Word	195	Swastika Rimmed Ornaments	195
Lining Ronaldson O. S. No. 112	21	Ovals and Circles, Brass	242-247	Sylph and Sylph Outline Borders	198, 199
Lining Smith Premier No. 3	54	PALISADE Ornaments	208	Sylph Stippled Border	200
Lining Tudor Black No. 3	75	Panel Borders	208	Symphony Ornaments	278-281
Lining Viking O. S. Italic No. 3	49	Parenthesis	167	Sylph Initials	216
Lining Viking O. S. No. 3	33, 50, 51	Piece Accents	44		
Lino. Gothic, Special	169	Piece Fractions	167	TAILPIECE Ornaments	206
Lions	195	Perforating Rule, Brass	231	Teddy Bear Ornaments	196
Logotypes	166, 167	Perforating Rule, Steel	231	Thin Spaces, Brass and Copper	261
		Plate Roman	152	Title Condensed No. 75	73
MAILING Type	169	Pointers		Tokio	134, 135
Maltese Cross Borders	188	No. 1	182	Trade Signs	231
Marguerite Borders	192	Shaded	182	Tudor Black No. 3, Lining	75
Mastodon	128-130	Arrow	182	Twin Buffalo Borders	190
Medium Gothic No. 7	116, 117	Editorial	168	Typewriter Type	
Metal Furniture	258-260	Brass	242	Lining Smith Premier No. 3	54
Metal Rule	242	Post Card Headings	282	Stenograf	54
Miscellaneous Characters	166-168	Poster Antique No. 31	161	Typewriter No. 1	54
Miscellaneous Signs	166	Poster Buffalo	158-159		
Modern Antique No. 3, Lining	102, 103	Poster Buffalo Outline	155	UNEEDA Border	210
Moons	169	Poster Cambridge	164	University Border	212
Muller Ornaments	208	Poster Lining Hansen O. S. No. 30	165		
Multiplex Borders	186, 187	Poster Lining Hansen O. S. No. 40	163	VERTICAL Script	149
		Poster Lining De Vinne	156	Victoria Italic	154
NATIONAL ROMAN, Lining	26, 27	Poster Lining De Vinne Condensed	157	Viking O. S. Italic No. 3, Lining	49
National Roman Italic, Lining	28	Poster Lining Latin Antique	162	Viking O. S. No. 3, Lining	33, 50, 51
New Cambridge	376	Poster Stratford O. S.	160		
Newspaper Body Types	24	Printers' Joys	207	WAVERLEY Bands	200
Newspaper Headings, Electrotypes	181	Puritan Series	62-65	Weight Font Prices of Type	18
Newspaper Sub-Headings, Electrotypes	180			Winchendon	137
Newton Script	150, 151	QUOTATIONS, Metal	258, 259	Wood Borders and Ornaments	323-325
		Quotations, Beveled	256, 257, 378	Wood Indexes	324
OLD STYLE Italic No. 110, Lining	28	Quotations, High Metal	258	Word Ornaments	195
Old Style Italic No. 112, Lining	28			Wood Silhouettes and Catchwords	323
Old Style No. 110, Lining	20	RECIPE Signs	166	Wood Type	315-322
Ornaments		Reliance Borders	188		
Aladdin	205	Roman No. 2	25	ZION Border	168
Aleppo	195	Roman No. 3	25		

If the Type Face, Border or Ornament that you are looking for cannot be found in this index, be sure and write us for same.



INDEX TO MACHINERY AND MATERIALS—Continued

MAILING Galleys	334	Presses, Cylinder		Sectional Blocks, Metal	342
Mailing Machine Gum	384	Diamond	359	Sectional Blocks, Steel	342
Mailing Machine, Horton	333	Stonemetz	368	Shears, 30-Inch Iron Frame	367
Make-up and Composing Rules	328	Whitlock	354	Shoot-Board and Type-High Machine	351
Mallets and Planers	314	Presses, Hand	351, 352	Shooting Sticks	338
Masterman Composing Room Cabinet	296	Presses, Platen		Slauson Cylinder Press Locks	344
Mastodon Cabinet	305	Challenge	359	Slug Cutting Attachment for any Saw Table	360
Medora Lead and Slug Bank	309	Chandler & Price	355	Southworth Punching Machine	336
Mentges Folder	361	Colt's Armory	358, 374	Space and Quad Case, 30-Inch	294
Metal Gravers	336	Gally Universal	356, 374	Spaceless Job Case	289, 292
Metal Furniture Cases	291, 294	Golding	356	Space Rule Case	312
Metropolitan Imposing Stone Frame	313	Pearl	355	Spatulas and Ink Knives	352
Midget Safety Quoin	332	Peerless	355	Standard Job Stick	329
Miller Saw Trimmer	360	Prouty	357	Staple Binders	
Miter Boxes	328	Pressman's Knife	350	Acme	357, 378
MITERING MACHINE, HANSEN'S		Press Points	327	Boston	364
COMPLETE	326	Press Punches, Ejector	341	Lightning	357
Monitor Paging and Numbering Machine	359	Press Room Cabinet, Dorsey	309	Midget	357
Monitor Perforators	366	Printers' Saw Table	360	Steel Furniture	344
Monitor Wire Stitchers	364	Printing Inks	384	Stephen's Expansion Locks, Improved	332
Monotype Cabinet	306	Proof Presses		Stereotype Beating Brushes	368
Monotype Work Bench	306	Challenge	353	Stereotype Blocks, Patent	335
Morton Lock-up	332	Chandler & Price	353	Sterling Round Cornering Machine	345
Multiplex Punch, Monitor	369	Golding	353	Stonemetz Cylinder Press	368
Multiplex Punches	363	Herald	353		
		Web Self Feeding, Self Inking	353		
		Proof Reader's Desk	309	TABLET Knives	341
NATIONAL Paper Cutter	371	Punches, Half-tone Softening	336	Tablet Presses	330
New Departure Cabinets	303, 306	Punches, Multiplex	363	Tablet Presses, Cott's Improved	368
New Departure Cases	288-293	Punches, Unimatic	363	Take Slugs, Electrotyped and Brass	331
New Model Perforator	367	Punch Heads, Unimatic	363	Tape Couplers, Roberts	368
News Cases	288	Punching Machine, Southworth	336	Tape for Presses and Folding Machines	349
Newspaper File	338	Punch, Monitor Multiplex	369	Thin Space Cases	261
New York Case Stand	298			Tie-up Slugs, Challenge Metal	353
New York Drying Rack	299	QUADRUPLE Case	289	Tracy Steel Run Stands	295
Numbering Machines, Bates	339	Quarter Size Cabinets	308	Triple Cases	289
Numbering Machines, Hand	339	Quoin Keys	332	Tweezers	341
Numbering Machines, Wetter	340	Quoins and Locking Devices	337	Twentieth Century Unit Type Cases	302
		Quoins, Wood	338	Two Rivers Cap Case	288
				Two Rivers Lead and Slug Case	289
OFFICIAL Press	351			Typan Gauge Square	352
Oily Waste Cans	330	RACHETS for Stereotype Blocks	335	Type-High Gauge	343
Oswego Paper Cutters	371, 372	Reading Glasses	330	Type-High Machine, Challenge	351
Oswego Paper Cutters Bench	373	Redington Counting Machine	333	Type Measures, Hansen	331
Overhead Fixtures	350	Reducing Compound	384		
Overlay Knives	350	Reducing Glasses	330	UNIMATIC Punches	363
		Register Hooks		Unimatic Punch Heads	363
PAD Cement	384	Eureka	342	Union Composing Stick	329
Padding Composition	384	Kyle	342	Universal Duster and Bellows	338
Padding Glue, Burrage	383	Little Giant	342	Utility Bench Cutter	373
Paging and Numbering Machine, Monitor	359	Quickest	342	Utility Imposing Frames	308
Paper Counters	341	Swivel	342		
Paper Cutters		Brass Catches	342	VARNISHES	384
Brown & Carver	370	Register Quoins, "Rouse"	327	Vibrator, Ideal	327
Chandler & Price	368, 372	Reglet and Furniture, Wood	311	Vibrator for Chandler & Price Press	355
Morgans & Wilcox Bench	373	Reglet Cases	311		
National	371	Roller Brackets	300	WELLS Job Cases	289
Oswego	371, 372, 373	Roller Recasting	350	Wesel Linotype Galleys	334
Oswego Bench	373	Roller Supporters, Steel	352	Wetter Numbering Machines	340
Peerless Gem	372	Rosback Perforators	366, 367, 369	Wheeler Job Case	285
Utility Bench	373	Round Cornering Machine	345	Whitlock Cylinder Presses	354
Paper Cutter Sticks	373	Rouse Job Stick	329	Wickersham Perfected Quoins	332
Paper Jogger, Combination	343	Rule Cases		Wire Stitchers	
Paste, Sphinx	384	Hamilton	287	Boston	364
Perfect News Stick	329	Harris	295	Monitor	364
Perforating and Scoring Machine, Bates	339	Harris	286	Wisconsin Cabinets	301, 310
Perforating and Scoring Machine, Damon	349	Neshota	290	Wisconsin Lead Rack	312
Perforators		Ordinary	290	Wood Furniture and Reglet	311
HANSEN Improved Pinhole	365	Perfection	287	Wood Galleys	314
Monitor	366	Sanspareil	287	Wood Quoins	338
New Model	367	Space	312	Wood Type Cabinets	303
Rosback	366, 367, 369	Zenobia	291	Wood Type Cases	290, 291
Planers and Mallets	314	Rule Curving Machine, Hansen's	365	Wrought Iron Case Stands, Wesel	298
Pliers	350	Ruling Machine, Hickok	361		
Pocket Rule Case	328			Yankee Job Case	288, 292
Polhemus Cabinets	304	SAW TABLE, Printers'	360	Yankee Job Stick	329
Porter's Patent Extension Front Steel Run Cabinet	302	Saw Trimmer, Miller	360		
Poster Sticks, Wood	328	Screw Drivers	332		

We invite you to compare our specimen book with others. Take notice of the printing of our mitered rule sets—they are not soldered at the joints and are all printed direct from rule and type (not electrotypes)

THE H. C. HANSEN TYPE FOUNDRY



ESTIMATES FOR JOB OFFICES

All List Prices

\$1500 OUTFIT

1 8x12 Chandler & Price, complete	\$165.00
1 12x18 Golding Jobber, complete	420.00
1 30-inch Chandler & Price Lever Cutter	150.00
1 Imposing Stone and Frame, 48x60 inches	35.00
Job Type Faces, to be selected	about 225.00
25 Pounds 6-pt. Roman or Old Style	18.70
100 Pounds 8-pt. Roman or Old Style	60.30
100 Pounds 10-pt. Roman or Old Style	52.60
50 Pounds 12-pt. Roman or Old Style	24.30
1 Font 12-pt. Typewriter Type	7.00
Spaces and Quads	about 30.00
6 Pairs News Cases	9.60
1 No. 68 New Departure Cabinet with 50 California Job Cases	74.00
1 Steel Run Stand No. 21	20.00
4 Pair Case Brackets	5.00
20 California Job and Triple Cases	18.00
50 Pounds 2-pt. L. S. Leads	10.00
50 Pounds 6-pt. L. S. Slugs	10.00
2 Lead and Slug Cases	2.00
25 Pounds Improved L. S. Metal Furniture	6.25
1 Metal Furniture Case	1.50
1 Hansen Complete Lead and Rule Cutter	18.00
1 Hansen Complete Mitering Machine	18.50
10 Pounds 2-pt. Leads, in strips	1.60
5 Pounds 2-pt. L. S. Single Rule No. 109	7.25
3 Pounds 2-pt. Dotted Rule No. 113	4.50
3 Pounds L. S. Beveled Rule No. 508	4.50
5 Pounds 6-pt. L. S. Double Rule No. 186	6.50
5 Pounds 6-pt. L. S. Face Rule	6.50
1 Font Special Mitered 4-pt. Parallel Rule No. 521	19.75
1 Set (4) Harris Rule Cases No. 1 in Blank Case	4.65
1 Case each Brass and Copper Thin Spaces	5.00
100 Yards 6-pt. and 12-pt. Reglet	2.00
1 Font L. S. Wood Furniture and Case No. 12	10.00
4 Dozen Improved Hempel Quoins No. 1 and 2 Keys	11.00
1 All Brass Job Galley, 10x16 inches	3.25
1 All Brass Job Galley, 12x18 inches	4.00
2 Double Column All Brass Gallies	6.00
1 Mallet, Planer and Proof Planer	1.20
2 6-inch Yankee Sticks	1.40
1 10-inch Graduated Job Stick	2.25
1 12-inch Grover or Buckeye Stick	1.40
Assortment of Ink	about 10.00
Borders and Ornaments	about 15.00
1 Benzine Can and Brush and 1 Pair Bellows	2.25

1510.75

Above prices subject to discount

Figures cheerfully submitted on complete plants of any size

\$450 OUTFIT

1 8x12 Chandler & Price or Challenge Gordon, complete	\$165.00
1 23-inch Chandler & Price Lever Cutter	95.00
1 Imposing Stone 24x36 inches	6.00
50 Pounds 10-pt. Roman or Old Style	26.30
Job Type, to be selected	about 80.00
1 Pair News Cases	1.60
15 California Job Cases and 4 Triple Cases	17.10
Spaces and Quads	10.00
1 Double Stand No. 15, for 24 Full Size Cases	6.00
2 Pound Font 2-pt. L. S. Single Rule	3.20
2 Pound Font 2-pt. L. S. Beveled Rule No. 508	3.20
2 Compact Rule Cases	1.80
25 Pounds L. S. Leads and Slugs	5.00
1 Lead and Slug Case	1.00
10 Pounds 2-pt. Leads, long	1.60
1 Lead and Rule Cutter No. 1	6.00
1 Half Font L. S. Furniture in Case No. 10	6.00
1 Dozen Challenge Hempel Quoins No. 1 and Key	1.50
1 All Brass Job Galley, 8 1/2 x 13 inches	2.50
1 6-inch Yankee Job Stick	.70
1 12-inch Buckeye or Grover Stick	1.40
1 Mallet, Planer and Proof Planer	1.20
50 Yards 6-pt. and 12-pt. Reglet	1.00
1 Benzine Can and Brush	.95
1 Pair Bellows	1.00
1 Case Copper and Brass Thin Spaces	1.75
Assortment of Ink	about 5.00
Borders and Ornaments	about 6.00

\$457.80

A 7x11 Pearl Press No. 11 may be substituted for the press in this outfit. Price, complete, \$147.00

Above prices subject to discount

\$800 OUTFIT

1 10x15 Chandler & Price with long fountain and steam fix.	\$230.00
1 26-inch Chandler & Price Lever Cutter	115.00
1 Imposing Stone and Frame, 26x44 inches	16.00
50 Pounds 8-pt. Roman or Old Style	30.15
50 Pounds 10-pt. Roman or Old Style	26.30
25 Pounds 12-pt. Roman or Old Style	12.30
3 Pairs News Cases	4.80
Job Type, to be selected	about 150.00
Spaces and Quads	25.00
1 Double News Stand No. 15	6.00
20 California and Triple Cases	18.00
1 New Departure Cabinet No. 66, with 40 California Job Cases	59.25
2 Pair Case Brackets	2.50
25 Pounds L. S. Metal Furniture	6.25
50 Pounds L. S. Leads and Slugs	10.00
1 Lead and Slug Case	1.00
5 Pounds 2-pt. L. S. Single Rule No. 109	7.25
3 Pounds 2-pt. L. S. Beveled Rule No. 508	4.50
5 Pounds 2-pt. L. S. Dotted Rule No. 113	7.25
5 Pounds 6-pt. L. S. Double Rule	6.50
2 Harris Rule Cases No. 1	2.50
1 Case Copper and Brass Thin Spaces	1.75
1 Mallet, Planer and Proof Planer	1.20
1 Dozen Improved Hempel Quoins and 1 Key	3.00
1 All Brass Job Galley, 10x16 inches	3.25
2 All Brass Double Column Gallies	6.00
1 Font L. S. Furniture and Case No. 12	10.00
1 Hansen Complete Lead and Rule Cutter	18.00
1 Hansen Complete Mitering Machine	18.50
10 Pounds 2-pt. Leads, long	1.60
1 6-inch Yankee Stick and 1 12-inch Buckeye Stick	2.10
100 Yards 6-pt. and 12-pt. Reglet	2.00
Assortment of Ink	about 7.50
Borders and Ornaments	12.00
1 Benzine Can, Brush and 1 Pair of Bellows	2.25

\$829.70

Above prices subject to discount

The substitution of different classes of machinery and material such as Power Cutters, etc. will increase or decrease the above figures

\$650 OUTFIT

1 10x15 Chandler and Price Job Press	\$200.00
1 Set of Steam Fixtures for above press	10.00
1 Long Fountain	20.00
1 26-inch Chandler & Price Lever Paper Cutter	115.00
1 Hansen Complete Mitering Machine	18.50
1 Hansen Complete Lead and Rule Cutter	18.00
1 Cabinet, Flat Top, for 20 two-thirds size Job Cases	21.00
1 Double City Stand with racks for 30 full size Cases and 2 pairs News Cases	8.00
1 Marble Imposing Stone and Frame 24x36 inches	13.25
1 Dozen Challenge Hempel Quoins and Key	1.50
2 Pairs News Cases	3.20
1 Blank Case with two Compact Rule Cases	2.45
1 Eureka Lead and Slug Rack	2.50
20 California Job Cases, full size	18.00
5 Triple Cases, full size	4.50
1 10x16 Job Galley	3.25
1 Double Col. Brass Galley 6 1/2 x 23 1/2	3.00
1 12-inch Yankee Job Stick	1.10
1 6-inch Rouse Graduated Job Stick	1.75
Mallet, Planer, 1-qt. Benzine Can and Benzine Brush	1.75
20 Pounds Full Length 2-pt. Leads	3.20
50 Pounds L. S. Leads and Slugs	10.00
25 Pounds Metal Furniture	6.25
5 Pounds 2-pt. Rule No. 109	7.25
5 Pounds 2-pt. Rule No. 113	7.25
25 Pounds 8-pt. Body Type	15.25
50 Pounds 10-pt. Body Type	26.30
30 Fonts of Job Type	about 85.00
1 Half Case L. S. Wood Furniture	6.00
Yards each 6-pt. and 12-pt. Reglet	1.00
Borders, Ornaments, Dashes, etc.	15.00
Spaces and Quads	20.00

\$669.25

Above prices subject to discount

Superior Quality, Prompt Service and Fair Prices

The estimates given above are approximate and are subject to variations called for by the individual conditions

INFORMATION

HOW TO ORDER *Credit*—If you have not had any previous account with us and are not rated in any Mercantile books, please supply us with references. If you need immediate shipment and you are unknown to us or have not supplied references, then send a remittance with order or request us to ship C. O. D.

Do Not Mutilate Book. When ordering, be as explicit as possible and mention by name and number. If you believe there is then a question, mention page of book on which such articles are shown. By no means cut out any part of the leaves.

Send Samples. If you are to match a type face you already have and are not positive of the name, send us a Cap "H" and i.c. "m" or refer to some previous invoice.

Check Goods Received. Be sure to check up your bill on receipt of same and if any complaints, prompt notice should be given.

Proofs of Fonts. If there is any question of a missing letter proofs of fonts should be taken and sent with your written letter.

Sorts. Minimum order for sorts is four ounces of each character. Minimum sort charge, 60 cents.

SHIPMENTS When shipping instructions are omitted, we will use our best judgment as to the way of making shipments. Customers should bear in mind that shipment of a small article or single font of type by freight is generally more expensive than express.

We advise sending weight of twenty-five pounds or less by express.

The law holds that after goods have been properly dispatched such shipments are at purchasers' risk, so please use judgment when requesting to send by mail.

Postage is charged in case order goes by mail.

If an order cannot be filled complete on receipt of same, it generally held for complete shipment; so in case you wish certain articles in a rush or any part that is ready immediately, please mention this with order. This delay may happen on account of weight orders, as such goods are not always in stock.

OLD METAL We take in exchange or make allowance for new type old metal such as foundry type, brass, plates, stereotypes, leads, slugs and metal furniture, delivered at the foundry, current prices.

Metal run together in pigs or zinc plates will not be taken at price.

Metal must not be mixed, but kept separate, otherwise it will be credited at lowest metal rate.

Plates or bases made by Press Associations, being the property of the manufacturers and only leased, will not be taken at any price.

OLD STANDARD QUADS For the convenience of many printing offices still having the old Boston or Dickinson standard bodies we can cast to order quads of the following sizes: Pearl, Nonpareil, Minion, Brevier, Bourgeois, Long Primer, Small Pica, Pica, and Great Primer.

GUARD LINES Finished Metal Guard Lines or Bearers for Electrotyping, full length or cut, 25 cents per pound.

BRASS TYPE Can furnish Brass Type for use of bookbinders, badge printers and box makers, in the following faces: Gothic Condensed No. 4, Modern Antique, Gothic No. 18, Latin Condensed, Gothic No. 3, Hansen O. S. No. 40, Card Roman, Lining Gothic Extended, French Old Style, Latin Antique, Howland and De Vinne. Prices on request.

WEIGHT FONT PRICES. (Subject to Discount)
FIRST CLASS PRICES

PRICES OF WEIGHT FONTS						
JOB and BODY TYPE						
Subject to change without notice. March 2, 1911						
Weight up to next quantity	20 lbs.	100 lbs.	500 lbs.	1000 lbs.	2000 lbs.	
Pt. Size	Per lb.	Per lb.	Per lb.	Per lb.	Per lb.	
*5	\$1.05	\$0.97	\$0.95	\$0.94	\$0.92	
*5½	.92	.90	.88	.86	.84	
6	.79	.78	.77	.76	.74	
7	.69	.68	.66	.64	.63	
8	.64	.63	.62	.60	.58	
9	.60	.59	.58	.56	.55	
10	.56	.55	.54	.53	.52	
11	.55	.53	.52	.51	.50	
12	.52	.51	.49	.48	.47	
14	.50	.49	.48	.47	.46	
16	.50	.49	.48	.47	.46	
18	.50	.49	.48	.47	.46	
20 to 66	.49	.49	.48	.47	.46	
72	.48	.48	.47	.46	.45	

Write for Special Rates on Larger Quantities

NOTE—Fonts ordered at one time to regular scheme of one body, face and line.
 *5-Pt. and 5½-Pt. in 10 lbs. or multiples
 6-Pt. to 18-Pt. in 20 lbs. or multiples
 20-Pt. to 36-Pt. in 25 lbs. or multiples
 42-Pt. to 72-Pt. in 50 lbs. or multiples
 *50 lbs. 5-Pt., per lb. \$1.00 50 lbs. 5½-Pt., per lb. \$0.91

All our Job and Body Faces sold in Weight Fonts at these Prices excepting Scripts, Shaded and special faces

THE H. C. HANSEN TYPE FOUNDRY

6-PT. UNION BORDER. 60 INCHES \$1.50

Pt.	Approx. Wt.	Price Job Fonts	Price 5-lb. Fonts	Pt.	Approx. Wt.	Price Job Fonts	Price 5-lb. Fonts
	lbs. oz.				lbs. oz.		
5	1 0	\$1.20	\$6.00	24	1 14	\$1.00	\$2.35
5½	1 0½	.85	4.00	26	1 14	1.00	2.35
6	0 15	.70	3.50	28	1 14	1.00	2.35
7	1 11	.80	3.20	30	1 14	1.00	2.35
8	1 1	.75	3.00	32	1 14	1.00	2.35
9	1 2½	.75	2.80	36	2 2	1.15	2.35
10	1 3½	.75	2.65	40	2 6	1.30	
11	1 2½	.65	2.50	42	2 6	1.30	
12	1 3½	.65	2.40	44	2 6	1.30	
14	1 6	.75	2.35	48	2 12	1.50	
15	1 10	.90	2.35	54	3 2	1.70	
16	1 14	1.00	2.35	60	3 6	1.80	
18	1 14	1.00	2.35	66	3 12	2.00	
20	1 14	1.00	2.35	72	4 0	2.15	
22	1 14	1.00	2.35				

40-Pt. and larger not sold in 5-lb. fonts.

These prices apply to Spaces and Quads in Job Fonts. Fonts of Spaces and Quads contain one-half Spaces and one-half Quads.
 *Prices and Discounts Subject to Change Without Notice

THE H. C. HANSEN TYPE FOUNDRY

STANDARD LINE

WE call attention to the fact that all the leading type faces shown in this specimen book are cast on **Standard Line**. Standard Line is the principle by which all faces of one body line automatically at the foot without justification, and different bodies can be lined together by the use of point leads or point slugs in justification.

In a few cases, certain type faces, such as the Gothic No. 1, Gothic Cond. No. 5, etc., are cast on Point Line, which indicates that different bodies of the same series can be made to line with each other by justification of point leads and slugs.

A few faces, such as Typewriter Type, Caslon Old Style No. 1 and Gothic Cond. No. 4, are left on the original line to preserve the special features of the design, also to allow use of more words in a given space, as it avoids placing a small face on a larger body. Certain such faces can be cast to order, in weight fonts, on the Standard Lining System.

48-PT. 'PHONE ORNAMENT
200. EACH



Our Two Telephones
2737 Main
2738 Main

LINING OLD STYLE No. 110

JOB FONTS

6-Point 28A \$0.90 56a \$1.10 \$2.00 20A \$0.50

A COMPARISON OF IDEAS IS ALWAYS educational, and as such instructs the brain and hand of man. Friendly rivalry follows, which is THE SPUR TO INDUSTRIAL IMPROVEMENTS

8-Point 23A \$1.10 46a \$1.15 \$2.25 14A \$0.50

IF PERCHANCE SOME OF OUR tariffs are no longer needed for revenue or to encourage and protect our home INADEQUATE STEAMSHIP SERVICE

10-Point 20A \$1.15 40a \$1.35 \$2.50 14A \$0.50

A COMPARISON OF IDEAS is always educational, and as such instructs the brain and hand of THE MAN AT THE CASE

12-Point 16A \$1.30 32a \$1.45 \$2.75 9A \$0.50

BEFORE YOU ORDER your new type and printing material, carefully consider FINEST QUALITIES

18-Point 12A \$1.65 24a \$1.60 \$3.25 6A \$0.50

FINE PRINTING obtained by the use of Hansen's superior BOOK AND JOB TYPE

25 pounds and multiples 47c. per lb.

25 pounds and multiples 6-Point 76c. per lb.

A REPUTATION for promptness is one of the things that a job printer should strive for. He will have gained a great advantage when it comes to be said of him that he always gets work out on time, and it will pay him to endeavor to secure such a reputation by every means in his power. We know how prone is the ordinary business man to wait until he is clean out of stationery, or whatever he wants, before ordering more, or to postpone until the latest possible moment the order for circulars, handbills, or any bit of commercial work: and then, when he does give you the order, he acts as though he thought

Leaded with 2-Point leads Lower case a to z 14½ ems

25 pounds and multiples 8-Point 62c. per lb.

A REPUTATION for promptness is one of the things that a job printer should strive for. He will have gained a great advantage when it comes to be said of him that he always gets work out on time, and it will pay him to endeavor to secure such a reputation by every means in his power. We know how prone is the ordinary business man to wait until he is clean out of stationery or whatever he wants, before ordering more, or to postpone until the last

Leaded with 2-Point leads Lower case a to z 13½ ems

25 pounds and multiples 10-Point 54c. per lb.

A REPUTATION for promptness is one of the things that a job printer should strive for. He will have gained a great advantage when it comes to be said of him that he always gets work out on time, and it will pay him to endeavor to secure such a reputation by every means in his power. We know how prone is the ordinary business man to wait until he is clean

Set solid Lower case a to z 12½ ems

25 pounds and multiples 11-Point 52c. per lb.

A REPUTATION for promptness is one of the things that a job printer should strive for. He will have gained a great advantage when it comes to be said of him that he always gets work out on time, and it will pay him to endeavor to secure such a reputation by every means in his power. We know how prone is

Set solid Lower case a to z 12 ems

25 pounds and multiples 12-Point 50c. per lb.

A REPUTATION for promptness is one of the things that a job printer should strive for. He will have gained a great advantage when it comes to be said of him that he always gets work out on time, and it will pay him to endeavor to secure

Set solid Lower case a to z 12½ ems

When ordering to match type in case, send Cap "H" and l.c. "m"

THE H. C. HANSEN TYPE FOUNDRY

LINING RONALDSON OLD STYLE No. 112

25 pounds and multiples 6-Point 76c. per lb.

A REPUTATION for promptness is one of the things that a job printer should strive for. He will have gained a great advantage when it comes to be said of him that he always gets work out on time, and it will pay him to endeavor to secure such a reputation by every means in his power. We know how prone is the ordinary business man to wait until he is clean out of stationery, or whatever he wants, before ordering more, or to postpone until the latest possible moment the order for circulars, handbills, or any other bit of

Leaded with 2-Point leads Lower case a to z 17½ ems

25 pounds and multiples 8-Point 62c. per lb.

A REPUTATION for promptness is one of the things that a job printer should strive for. He will have gained a great advantage when it comes to be said of him that he always gets work out on time, and it will pay him to endeavor to secure such a reputation by every means in his power. We know how prone is the ordinary business man to wait until he is clean out of stationery, or whatever he wants

Leaded with 2-Point leads Lower case a to z 14½ ems

25 pounds and multiples 10-Point 54c. per lb.

A REPUTATION for promptness is one of the things that a job printer should strive for. He will have gained a great advantage when it comes to be said of him that he always gets work out on time, and it will pay him to endeavor to secure such a reputation by every means in his power. We know how prone is the ordinary business man to wait

Set solid Lower case a to z 14 ems

25 pounds and multiples 11-Point 52c. per lb.

A REPUTATION for promptness is one of the things that a job printer should strive for. He will have gained a great advantage when it comes to be said of him that he always gets work out on time, and it will pay him to endeavor to secure such a reputation by every means in his power.

Set solid Lower case a to z 13½ ems

25 pounds and multiples 12-Point 50c. per lb.

A REPUTATION for promptness is one of the things that a job printer should strive for. He will have gained a great advantage when it comes to be said of him that he always gets work out on time, and it will pay him to

Set solid Lower case a to z 13½ ems

JOB FONTS

6-Point 24A \$0.85 48a \$1.15 \$2.00 20A \$0.50

A COMPARISON OF IDEAS IS ALWAYS educational, and as such instructs the brain and hand of man. Friendly rivalry
THE SPUR TO IMPROVEMENTS

8-Point 20A \$1.05 40a \$1.20 \$2.25 15A \$0.50

WHEN PERFECT TYPE IS CAST there is no excuse for poor printing if the details of presswork are carried
FINEST SELECTION OF TYPES

10-Point 20A \$1.20 40a \$1.30 \$2.50 13A \$0.50

COMPARISON OF IDEAS is always educational, and as such instructs the brain and
HAND OF MECHANICS

12-Point 18A \$1.45 36a \$1.30 \$2.75 10A \$0.50

PRACTICE ECONOMY in your business when it is necessary but remember
THE TYPE THAT WEARS

18-Point 10A \$1.55 21a \$1.70 \$3.25

ASK FOR TYPE with the Diamond Nick, and you will get the very finest

25 pounds and multiples 47c. per lb.

When ordering to match type in case, send Cap "H" and l.c. "m"

THE H. C. HANSEN TYPE FOUNDRY



LINING ROMAN No. 40

STANDARD LINE

25 pounds and multiples

6-Point

76c. per lb.

EVEN IN THE ART OF PRINTING, PROGRESS, THOUGH CONTINUOUS, WAS EXCEEDINGLY SLOW FOR THREE HUNDRED AND FIFTY YEARS, and although the volume of printed matter has increased much more rapidly during the last half century, responsive to the conditions of our age, the use of printing is still largely a matter of habit and education, varying widely in different nations, and even among the various states of our own Republic. This fact is illustrated by the expenditures of state governments for official printing, which show differences so great as to be explainable only by the habit of the sparing or of the liberal use of printed matter. The state of New York, for example, has long been foremost among all the states in the production of printing; in 1900 the state government expended \$654,330.53 for official printing, while the state officials of Tennessee, a state in which printing is a minor industry and much less a factor in daily life, expended in the same year but \$8,136.38. The proportion, therefore, of official printing was twenty times as great in New York as in Tennessee. On the whole, however, the advance of the United States during the last fifty years, which may be set as the period of greatest industrial activity, has been so great and far reaching as to place the industry among the leaders, and to arouse some curiosity concerning the part which the printer has played in this half century competition among the great industries.—*The Printing Art*

ABCDEF GHIJKLMNOPQRSTUVWXYZ& ABCDEF GHIJKLMNOPQRSTUVWXYZ&
 Lower case a to z 16½ ems
 \$12345 abcdefghijklmnopqrstuvwxyz 67890

25 pounds and multiples

5-Point

\$1.20 per lb.

EVEN IN THE ART OF PRINTING, THE PROGRESS, THOUGH CONTINUOUS, WAS EXCEEDINGLY SLOW FOR THREE HUNDRED AND FIFTY YEARS, and although the volume of printed matter has increased much more rapidly during the last half century, responsive to the conditions of our age, the use of printing is still largely a matter of habit and education, varying widely in different nations, and even among the various states of our own Republic. This fact is illustrated by the expenditures of state governments for official printing, which show differences so great as to be explainable only by the habit of the sparing or of the liberal use of printed matter. The state of New York, for example, has long been foremost among all the states in the production of printing; in 1900 the state government expended \$654,330.53 for official printing, while the state officials of Tennessee, a state in which printing is a minor industry and much less a factor in daily life, expended in the same year but \$8,136.38. The proportion, therefore, of official printing was twenty times as great in New York as in Tennessee. On the whole, however, the advance of the United States during

ABCDEF GHIJKLMNOPQRSTUVWXYZ&
 Lower case a to z 16 ems
 \$12345 abcdefghijklmnopqrstuvwxyz 67890

25 pounds and multiples

5½-Point

88c. per lb.

IN THE ART OF PRINTING, PROGRESS, THOUGH CONTINUOUS, WAS EXCEEDINGLY SLOW FOR THREE HUNDRED AND FIFTY YEARS, and although the volume of printed matter has increased much more rapidly during the last half century, responsive to the conditions of our age, the use of printing is still very largely a matter of habit and education, varying widely in different nations, and even among the various states of our own Republic. This fact is illustrated by the expenditures of state governments for official printing, which show differences so great as to be explainable only by the habit of the sparing or of the liberal use of printed matter. The state of New York, for example, has long been foremost among all the states in the production of printing; in 1900 the state government expended \$654,330.53 for official printing, while the state officials of Tennessee, a state in which printing is a minor industry . . . The Printing Art

ABCDEF GHIJKLMNOPQRSTUVWXYZ&
 Lower case a to z 16½ ems
 \$12345 abcdefghijklmnopqrstuvwxyz 67890

25 pounds and multiples

7-Point

66c. per lb.

EVEN IN THE ART OF PRINTING, THE PROGRESS, THOUGH CONTINUOUS, WAS EXCEEDINGLY SLOW FOR three hundred and fifty years, and although the volume of printed matter has increased much more rapidly during the last half century, responsive to the conditions of our age, the use of printing is still largely a matter of habit and education, varying widely in different nations, and even among the various states of our own Republic. This fact is illustrated by the expenditures of state governments for official printing, which show differences so great as to be explainable only by the habit of the sparing or of the liberal use of printed matter. The state of New York, for example, has long been foremost among all the states in the production of printing; in 1900 the state government expended \$654,330.53 for official printing, while the state officials of Tennessee, a state in which printing is a minor industry and much less a factor in daily life, expended in the same year but \$8,136.38. The proportion, therefore, of official printing, to population, was twenty times as great in New York as in Tennessee. On the whole, however, the advance of the United States during the last fifty years, which may be set as the period of greatest industrial activity, has been so great and far reaching as to place the industry among the 213

ABCDEF GHIJKLMNOPQRSTUVWXYZ& ABCDEF GHIJKLMNOPQRSTUVWXYZ&
 Lower case a to z 16 ems
 \$12345 abcdefghijklmnopqrstuvwxyz 67890

25 pounds and multiples

8-Point

62c. per lb.

EVEN IN THE ART OF PRINTING, THE PROGRESS, THOUGH CONTINUOUS, WAS EXCEEDINGLY SLOW FOR three hundred and fifty years, and although the volume of printed matter has increased much more rapidly during the last half century, responsive to the conditions of our age, the use of printing is still very largely a matter of habit and education, varying widely in different nations and even among the different states of our own Republic. This fact is illustrated by the expenditures of state governments for official printing, which show differences so great as to be explainable only by the habit of the sparing or of the liberal use of printed matter. The state of New York, for example, has long been foremost among all the states in the production of printing; in 1900 the state government expended \$654,330.53 for official printing, while the state officials of Tennessee, a state in which printing is a minor industry and much less a factor in daily life, expended in the same year but \$8,136.38. The proportion, therefore, of official printing to population was twenty times as great in New York as in Tennessee. On the whole, however, the advance of the United States during the last fifty years, which may be set as the period of greatest industrial

ABCDEF GHIJKLMNOPQRSTUVWXYZ& ABCDEF GHIJKLMNOPQRSTUVWXYZ&
 Lower case a to z 14½ ems
 \$12345 abcdefghijklmnopqrstuvwxyz 67890

THE H. C. HANSEN TYPE FOUNDRY



LINING ROMAN No. 40

STANDARD LINE

25 pounds and multiples 10-Point 54c. per lb. 25 pounds and multiples 12-Point 50c. per lb.

EVEN IN THE ART OF PRINTING, THE Progress, though continuous, was exceedingly slow for three hundred and fifty years, and although the volume of printed matter has increased much more rapidly during the last half century, responsive to the conditions of our age, the use of printing is still very largely a matter of habit and education, varying widely in different nations, and even among the various states of our own Republic. This fact is illustrated by the expenditures of state governments for official printing, which show differences so great as to be explainable only by the habit of the sparing or of the liberal use of printed matter. The state of New York, for example, has long been foremost among all the states in the production of printing; in 1900 the state government expended \$654,330.53 for official printing, while the state officials of Tennessee, a state in which printing is** —*The Printing Art*

EVEN IN THE ART OF PRINTING, THE Progress, though continuous, was exceedingly slow for three hundred and fifty years, and although the volume of printed matter has increased much more rapidly during the last half century, responsive to the conditions of our age, the use of printing is still largely a matter of habit and education, varying widely in different nations, and even among the various states of our own Republic. This fact is illustrated by the expenditures of state governments for their official printing, which show differences so great as to be explainable only by the habit of the sparing or of the liberal use of printed matter. *The state of New York, for ex-*

ABCDEFGHIJKLMN OPQRSTUVWXYZ&

ABCDEFGHIJKLMN OPQRSTUVWXYZ&

Lower case a to z 13 ems

‡12345 abcdefghijklmnopqrstuvwxyz 67890

ABCDEFGHIJKLMN OPQRSTUVWXYZ&

ABCDEFGHIJKLMN OPQRSTUVWXYZ&

Lower case a to z 13½ ems

‡123 abcdefghijklmnopqrstuvwxyz 4567

25 pounds and multiples 24-Point 47c. per lb.

EVEN IN THE ART OF PRINTING,
The progress, though continuous, was slow for three hundred and fifty years, and although the volume of printed matter has increased much more rapidly during the last half century, responsive to the conditions of our age, the use of printing is still very largely a habit and education vary-

ABCDEFGHIJKLMN OPQRSTUVWXYZ

Lower case a to z 13½ ems

123 abcdefghijklmnopqrstuvwxyz 456

When ordering to match type in case, send Cap "H" and l. c. "m"

For job fonts see page 28

SPECIMENS OF NEWSPAPER BODY TYPE

Manufactured from Superior Copper Amalgam Metal by The H. C. Hansen Typé Foundry, Boston

JUMPS RAIL IN ALLSTON

Many Passengers Cut by Glass as Two of
Cars Toppie Into Ditch

ONE PASSENGER SERIOUSLY INJURED

A train inbound from Worcester over the Boston & Albany, and running express from Riverside, jumped the rail about 25 yards west of a switch tower in Allston at 6:46 last evening and bumped along the sleepers, smashing them into fine bits, a distance of 100 yards. It came to a stop within 15 feet of the Cottage Farm bridge.

There were about 100 passengers aboard the train, yet all escaped without serious hurt except C. W. Harvey, of the R. G. Binford Electric Agency of this city. He was seriously injured about the back and was taken from the wrecked car overcome.

SETTLE THEIR DIFFERENCES

Universities of Chicago and Wisconsin Will Renew
Football Next Fall

CHICAGO, Feb. 18—Chicago and Wisconsin will meet in football next November at Marshall field. The Maroons and Cardinals, who have been estranged on the gridiron for the past two years, will renew their acquaintance in the final game of the 1908 season, according to word received today from coach A. A. Staggs.

The Chicago-Wisconsin arrangement consummates the long hoped for "big three" intercollegiate plan, by which Chicago, Wisconsin and Minnesota will participate in championship games as the western leaders.

Coach Staggs is looking to the east for one of the big games, and the Carlisle Indian team is thought to be an eastern possibility.

10, 12, 18 and 30-Pt. Gothic No. 400 and 6-Pt. Roman No. 40. Standard Line

NAME NOT WRIGHT

Mr. Quick Not Slow in Informing the Judge
of the Rights of the Matter Without Resort-
ing to Writing

A man who answered to the name of Jacob Quick appeared before Judge Burke in the municipal court yesterday morning charged with drunkenness. He said he lived in Cambridge.

"Why did you not give your right name?" demanded the judge.

"I did," replied the prisoner.

"The probation officer went to your home and reported that your name was Wright," said the judge.

"O, that's the name of the landlady who keeps the house," the defendant answered. "My name is Jacob Quick."

He was placed on probation under what he said was his right name, Quick, without reference to the other name, Wright, which he declared was wrong.

DISCUSS INTANGIBLE PROPERTY

The discussion before the Economic Club of that feature of the report of the recess commission on taxation which recommends to the Legislature a reduction of the tax on personal property showed a general approval of the plan.

Mr. Lucius Tuttle declared, with great truth, that the present system causes men with "intangible property" either to perjure themselves or to move away.

"The tax on intangible property—stocks and bonds—in all our large cities is simply farcical."

Very likely a reasonable rate upon such property would encourage full and fair returns and by so much add to the local revenues. It is an experiment

10, 12 and 24-Pt. Latin Condensed and 8-Pt. Roman No. 40. Standard Line

RESUME WORK

One Hundred Men Put at Work
More Likely to Follow

ON SHORT TIME SCHEDULE

More than 100 men went back to work at the navy yard yesterday morning, and 100 more will be put back at work within a day or two. They return under the recent order to reinstate all men laid off since Dec. 1 for lack of work or funds, whose discharge cards are satisfactory as to conduct and workmanship.

When the reinstated men have all reported the entire force of 2,400 men at the yard will go on short time, or a furlough, so as to give all an equal share.

LINCOLN SHRINE

Congress Asked to Add \$100,000 to Fund
for Memorial Building on Kentucky
Birthplace

Washington, Feb. 17—Mr. Maddison of Illinois today introduced a bill appropriating \$100,000 to be paid to the Lincoln Farm Association to build on Lincoln birthplace farm in Kentucky, a national patriotic shrine, which shall consist of a memorial hall costing not more than \$250,000, of which \$150,000 shall be paid by the association. According to the terms of the bill, the hall is to protect the humble weather-worn log cabin in which

10, 12, 18 and 24-Pt. De Vinne Condensed and 8-Pt. Roman No. 14. Standard Line

DEDICATE NEW CLUB BUILDING

Judge Lindsey and Many Other Notable
Guests Among Those Present

MARCH THE INTERESTING FEATURE

Fall River, Feb. 18—The new Boys' club building on Pocasset street was dedicated tonight in the presence of a gathering of twelve hundred people.

From 6 to 7:30 dinner was served to the invited guests and friends of the club, and from 7 to 8 o'clock the high school band gave a concert. This was followed by the dedicatory exercises. The addresses were interesting and were appreciated by the audience as shown by frequent applause.

One of the features of the exercises was the marching of nearly 500 boys before the assembled guests, each boy holding aloft a sign bearing the name of the country or state which he came from.

The building is three stories high, built of granite and pressed brick, and is 121 feet long and 60 feet wide and is the gift of M. C. D. Borden.

NO ROOM LARGE ENOUGH

So many men and women attended the hearing set for yesterday morning on the bills relative to the medical practitioners and registration in medicine that no committee room could be found at the state house that would contain them, and the hearing was postponed until March 3, when room 240, one of the largest in the state

12, 18 and 24-Pt. De Vinne Extra Condensed and 8-Pt. National Roman. Standard Line



LINING ROMAN No. 14

25 pounds and multiples

8-Point

62c. per lb.

EVEN IN THE ART OF PRINTING, THE PROGRESS, THOUGH CONTINUOUS, WAS VERY Slow for three hundred and fifty years, and, although the volume of printed matter has increased much more rapidly during the last half century, responsive to the conditions of our age, the use of printing is still very largely a matter of habit and education, varying widely in different nations, and even among the states of our own Republic. This fact is illustrated by the expenditures of state governments for official printing which show differences so great as to be explainable only by the habit of the sparing or of the liberal use of printed matter. The state of New York, for example, has long been foremost among all the states in the production of printing; in 1900 the state government expended \$654,330.53 for official printing, while the state officials of Tennessee, a state in which printing is a minor industry and much less a factor in daily life, expended in the same year but \$8,136.38. The proportion, therefore, of official printing to population was twenty times as great in New York as in Tennessee. On the whole, however, the * * * *—Printing Art

ABCDEFGHIJKLMN^oPQRSTU^vVWXY^z& \$1234567890 ABCDEFGHIJKLMN^oPQRSTU^vVWXY^z
 Lower case a to z 13½ ems
 abcdefghijklmnopqrstu^vvwx^yyz

LINING ROMAN No. 3

25 pounds and multiples

8-Point

62c. per lb.

EVEN IN THE ART OF PRINTING, PROGRESS Though continuous, was exceedingly slow for three hundred and fifty years, and, although the volume of printed matter has increased much more rapidly during the last half century, responsive to the conditions of our age, the use of printing is still very largely a matter of habit and education, varying in different nations, and even among the various states of our own Republic. This fact is illustrated by the expenditures of state governments for official printing, which show differences so great as to be explainable only by the habit of the sparing or of the liberal use of printed matter. The state of New York, for 1234

ABCDEFGHIJKLMN^oPQRSTU^vVWXY^z&
 ABCDEFGHIJKLMN^oPQRSTU^vVWXY^z
 Lower case a to z 13½ ems
 \$12345 abcdefghijklmnopqrstu^vvwx^yyz 67890

LINING ROMAN No. 2

25 pounds and multiples

10-Point

54c. per lb.

EVEN IN THE ART OF PRINTING, THE Progress, though continuous, was exceedingly slow for three hundred and fifty years, and, although the volume of printed matter has increased much more rapidly during the last half century, responsive to the conditions of our age, the use of printing is still largely a matter of habit and education, varying widely in different nations, and even among the various states of our own Republic. This fact is illustrated by the 12345

ABCDEFGHIJKLMN^oPQRSTU^vVWXY^z
 ABCDEFGHIJKLMN^oPQRSTU^vVWXY^z
 Lower case a to z 13½ ems
 \$12345 abcdefghijklmnopqrstu^vvwx^yyz 67890

ROMAN No. 8

25 pounds and multiples

USED EXTENSIVELY FOR LAW WORK
 11-Point

52c. per lb.

EVEN IN THE ART OF PRINTING, THE PROGRESS, THOUGH CONTINUOUS, Was exceedingly slow for three hundred and fifty years, and, although the volume of printed matter has increased much more rapidly during the last half century, responsive to the conditions of our age, the use of printing is still largely a matter of habit and education, varying widely in different nations, and even among the various states of our own Republic. This fact is illustrated by the expenditures of state governments for official printing, which show differences so great as to be explainable only by the habit of the sparing or of the liberal use of printed matter. The state of New York, for example, has

ABCDEFGHIJKLMN^oPQRSTU^vVWXY^z& ABCDEFGHIJKLMN^oPQRSTU^vVWXY^z
 Lower case a to z 13½ ems
 \$12345 abcdefghijklmnopqrstu^vvwx^yyz 67890



LINING NATIONAL ROMAN
STANDARD LINE

25 pounds and multiples 6-Point 76c. per lb.

EVEN IN THE ART OF PRINTING, THE PROGRESS, THOUGH Continuous, was exceedingly slow for three hundred and fifty years, and although the volume of printed matter has increased much more rapidly during the last half century, responsive to the conditions of our age, the use of printing is still very largely a matter of habit and education, varying widely in different nations, and even among the various states of our own Republic. This fact is illustrated by the expenditures of state governments for official printing, which show differences so great as to be explainable only by the habit of the sparing or of the liberal use of printed matter. The state of New York, for example, has long been foremost among all the states in the production of printing; in 1900 the state government expended \$654,330.53 for official printing, while the state officials of Tennessee, a state in which printing is a minor industry and much less a factor in daily life, expended in the same year but \$8,136.38. The proportion, therefore, of official printing to population was twenty times as great in New York as in Tennessee. On the whole, however, the advance of the United States during the last fifty years, which may be set as the period of greatest industrial activity, has been so great and far reaching as to place the industry among the leaders, and to arouse some curiosity concerning the part which the printer has played in this half century competition among the great industries. Fortunately it is possible to measure, approximately at least, the progress which the principal industries in the United States have made since 1850, for the federal census taken in that year, and commonly regarded as the first modern census, included statistics of manufactures. The results, however, cannot be regarded as entirely accurate. Invention, expansion and progress have wrought so mightily in the half century since 1850 that a statistical bottom firm enough to hold anchor would be especially welcome, but methods of enumeration and form of inquiry have so completely changed that even the least affected item, value of products, can be regarded only as a fair approximation. Yet with proper caution against too implicit confidence the figures of 1850 may be regarded as a valuable statistical base or starting point for many of the older or standard industries. In that 3

ABCDEFGHIJKLMN**OP**QRSTUVWXYZ&
\$12345 abcdefghijklmnopqrstuvwxy **z** £67890
ABCDEFGHIJKLMN**OP**QRSTUVWXYZ

25 pounds and multiples 10-Point 54c. per lb.

EVEN IN THE ART OF PRINTING The progress, though continuous, was exceedingly slow for three hundred and fifty years, and, although the volume of printed matter has increased much more rapidly during the last half century, responsive to the conditions of our age, the use of printing is still largely a matter of habit and education, varying widely in different nations, and even among the various states of our own Republic. This fact is illustrated by the expenditures of state governments for official printing, which show differences so great as to be explainable only by the habit of the sparing or of the liberal use of printed matter. The state of New York, for example, has long been foremost among all the states in the production of printing; in 1900 the state government expended \$654,330.53 for official printing, while the state of Tennessee, a state in which printing is a minor industry and much less a factor in daily life, expended in the same year but \$8,135.38. The proportion, therefore, of official printing to population was twenty times as great in New York as in Tennessee. On the whole however, the advance of the printing industry of the United

ABCDEFGHIJKLMN**OP**QRSTUVWXYZ&
\$12345 abcdefghijklmnopqrstuvwxy **z** £67890
ABCDEFGHIJKLMN**OP**QRSTUVWXYZ

25 pounds and multiples 8-Point 62c. per lb.

EVEN IN THE ART OF PRINTING, THE PROGRESS Though continuous, was exceedingly slow for three hundred and fifty years, and, although the volume of printed matter has increased much more rapidly during the last half century, responsive to the conditions of our age, the use of printing is still largely a matter of habit and education, varying widely in different nations, and even among the various states of our own Republic. This fact is illustrated by the expenditures of state governments for official printing, which show differences so great as to be explainable only by the habit of the sparing or of the liberal use of printed matter. The state of New York, for example, has long been foremost among all the states in the production of printing; in 1900 the state government expended \$654,330.53 for official printing, while the state of Tennessee, a state in which printing is a minor industry and much less a factor in daily life, expended in the same year but \$8,136.38. The proportion, therefore, of official printing to population was twenty times as great in New York as in Tennessee. On the whole, however, the advance of the printing industry in the United States during the last fifty years, which may be set as the period of greatest industrial activity, has been so great and far reaching as to place the industry among the leaders, and to arouse some curiosity concerning the part which the printer has played in this half century competition among the great industries. Fortunately it is possible to measure, approximately at least, the progress which the principal industries in the United States have made since 1850, for the

ABCDEFGHIJKLMN**OP**QRSTUVWXYZ&
\$12345 abcdefghijklmnopqrstuvwxy **z** £67890
ABCDEFGHIJKLMN**OP**QRSTUVWXYZ

25 pounds and multiples 11-Point 52c. per lb.

EVEN IN THE ART OF PRINTING The progress, though continuous, was exceedingly slow for three hundred and fifty years, and, although the volume of printed matter has increased much more rapidly during the last half century, responsive to the conditions of our age, the use of printing is still largely a matter of habit and education, varying widely in different nations, and even among the various states of our own Republic. This fact is illustrated by the expenditures of state governments for official printing, which show differences so great as to be explainable only by the habit of the sparing or of the liberal use of printed matter. The state of New York, for example, has long been foremost among all the states in the production of printing; in 1900 the state government expended \$654,330.53 for official printing, while the state officials of Tennessee, a state in which printing is a minor industry and much less a factor in daily life, expended in the same year but \$8,136.38. The proportion, therefore, of 1234

ABCDEFGHIJKLMN**OP**QRSTUVWXYZ&
\$12345 abcdefghijklmnopqrstuvwxy **z** £67890

JOB FONTS			
6-Point			
22A	\$0.90	44a	\$1.10 \$2.00
8-Point			
20A	\$1.10	40a	\$1.15 \$2.25
10-Point			
18A	\$1.20	40a	\$1.30 \$2.50
11-Point			
18A	\$1.30	40a	\$1.45 \$2.75
12-Point			
18A	\$1.35	30a	\$1.40 \$2.75
14-Point			
12A	\$1.40	20a	\$1.60 \$3.00
18-Point			
9A	\$1.50	18a	\$1.75 \$3.25
Small Caps sold separately			
Any body, 50c per font			

THE H. C. HANSEN TYPE FOUNDRY



LINING NATIONAL ROMAN

STANDARD LINE

25 pounds and multiples 12-Point 50c. per lb.
EVEN IN THE ART OF PRINTING
 Progress, though continuous, was exceedingly slow for three hundred and fifty years, and although the volume of printed matter has increased much more rapidly during the last half century, responsive to conditions of our age, the use of printing is still largely a matter of habit and education, varying widely in different nations, and even among the various states of our own Republic. This fact is illustrated by the expenditures of the state governments for official printing, which show differences so great as to be explainable only by the habit of sparing or of the liberal use of printed matter. The state of New York, for example, has long been foremost among all the states in the production of printing; in 1900 the state government 12
 ABCDEFGHIJKLMNOPQRSTUVWXYZ
 1235 abcdefghijklmnopqrstuvwxyz 6789

25 pounds and multiples 14-Point 47c. per lb.
EVEN IN ART OF PRINTING
 Progress, though continuous, was exceedingly slow for three hundred and fifty years, and, although the volume of printed matter has increased much more rapidly during the last half century, responsive to the conditions of our age, the use of printing is still largely a matter of habit and education, varying widely in different countries and among the various states of our own Republic. This fact is illustrated by the expenditures of the state governments for official printing, which show differences so great as to be explainable
 ABCDEFGHIJKLMNOPQRSTV
 12 abcdefghijklmnopqrstuvwxyz 35

All roman fonts contain 20 per cent. spaces and quads

25 pounds and multiples 18-Point 47c. per lb.
EVEN IN THE ART OF PRINTING, PROGRESS,
 Though continuous, was exceedingly slow for three hundred and fifty years, and, although the volume of printed matter has increased much more rapidly during the last half century responsive to the conditions of our age, the use of printing is still largely a matter of habit and education, varying widely in different countries and even among the various states of our own Republic. This fact is illustrated by the expenditures of the state governments for official printing, which show differences so great as to be explainable only by the habit of sparing or of the liberal use of printed matter. The
 ABCDEFGHIJKLMNOPQRSTUVWXYZ&
 \$12345 abcdefghijklmnopqrstuvwxyz 67890

THE H. C. HANSEN TYPE FOUNDRY



Lining O. S. Italic No. 110

STANDARD LINE

JOB FONTS

6-Point 20A \$0.90 50a \$1.10 \$2.00
A REPUTATION FOR PROMPTNESS
 Is one of the things that a job printer should strive for. He will have gained a great advantage when it comes to be said of him that he always get work out on time, and it will

8-Point 18A \$1.10 40a \$1.15 \$2.25
A REPUTATION FOR PROMPTNESS
 is one of the things that a job printer should strive for. He will have gained a great advantage when it comes

10-Point 16A \$1.15 40a \$1.35 \$2.50
THE REPUTATION FOR Promptness
 is one of the things that a job printer should strive for. He will have gained a great

11-Point 16A \$1.35 36a \$1.40 \$2.75
THE REPUTATION FOR Promptness
 is the one thing that job printers should strive for. They will have gained

12-Point 14A \$1.35 30a \$1.40 \$2.75
THE REPUTATION For promptness
 is one of the things that a job printer \$160

FOR ROMAN TO MATCH THIS TYPE SEE PAGE 20

Lining O. S. Italic No. 112

STANDARD LINE

JOB FONTS

6-Point 20A \$1.00 50a \$1.00 \$2.00
A REPUTATION FOR PROMPTNESS
 Is one of the things that a job printer should strive for. He will have gained a great advantage when it comes to be said of him that he always gets work out on time, and it will

8-Point 18A \$1.10 40a \$1.15 \$2.25
REPUTATION FOR PROMPTNESS
 is one of the things that a job printer should strive for. He will have gained a great advantage \$123

10-Point 16A \$1.10 40a \$1.40 \$2.50
THE REPUTATION FOR Promptness
 is one of the things that a job printer should strive for. He will have gained (\$2)

11-Point 16A \$1.25 30a \$1.50 \$2.75
A REPUTATION FOR Promptness
 is the one thing job printers should strive for. They will have gained a 12

12-Point 14A \$1.35 30a \$1.40 \$2.75
A REPUTATION FOR Promptness
 is one of the things that a job printer 2

FOR ROMAN TO MATCH THIS TYPE SEE PAGE 21

Lining National Roman Italic

STANDARD LINE

JOB FONTS

6-Point 22A \$0.90 40a \$1.10 \$2.00
A REPUTATION FOR PROMPTNESS
 Is one of the things that a job printer always should strive for. He has gained a great advantage when it comes to be said of him that he always gets work out on

8-Point 18A \$0.95 40a \$1.30 \$2.25
A REPUTATION FOR PROMPTNESS
 is one of the things that a job printer should strive for. He will have gained a great advantage when it \$6

10-Point 16A \$1.15 40a \$1.35 \$2.50
THE REPUTATION FOR \$2 Promptness
 is one of the things that a job printer should strive for. He has gained a great advantage in 2

11-Point 16A \$1.25 40a \$1.50 \$2.75
THE REPUTATION FOR Promptness
 is one of the things that a job printer should strive for. He will have gained 72

12-Point 12A \$1.25 34a \$1.50 \$2.75
THE REPUTATION For promptness
 is one of the things that a job print

FOR ROMANS TO MATCH THIS TYPE SEE PP. 26 AND 27

Lining Roman No. 40. Job Fonts

STANDARD LINE

5-Point 25A \$0.90 50a \$1.10 \$2.00
THE MARINER, SAILING IN THE BALTIC, AS HE
 Skirts the shores of Gotland, sees on a promontory of the island several large cairns and mounds overlooking the sea and the country that surrounds them. This promontory was the burial-place of a family of great Vikings and rulers who

5½-Point 26A \$0.85 52a \$1.15 \$2.00 20A \$0.50
THE PRINTERS OF THE EARLY CENTURIES
 strove to imitate the hand lettering of the scribes of their time which accounts for the imperfections in ALIGNMENT OF LETTERS WHICH APPEAR IN THE

6-Point 22A \$0.90 44a \$1.10 \$2.00 20A \$0.50
THE DAY RETURNS AND WITH IT COMES
 the glorious sunrise in the east, which, for an hour or more has been heralded by an exultant OUTBURST OF MUSIC FROM THE BIRDS AT 430

7-Point 20A \$1.10 40a \$1.15 \$2.25 18A \$0.50
JACK THE GIANT-KILLER, A HERO
 who did mighty deeds of valor overcoming wicked giants which grievously oppressed FROM TALES FOR THE CHILDREN 1234567890

24-Point

A WHISPER gently spoken
 by unexpected **DISTURBANCE**

When ordering to match type in case, send Cap "H" and l. c. "m"

8-Point 20A \$1.10 40a \$1.15 \$2.25 15A \$0.50
EXTRAORDINARY RESULTS EASILY
 obtained with Hansen's beveled quads avoiding use of Plaster Paris or paper FIVE DIFFERENT ANGLES 45 54 60 72 78

10-Point 18A \$1.20 40a \$1.30 \$2.50 14A \$0.50
AMBITIOUS PRINTERS FIND
 many attractive faces of type and labor-saving devices of great merit **BEST FOR THE PRINTER MAN 1230**

12-Point 18A \$1.35 36a \$1.40 \$2.75 10A \$0.50
ACQUIRE KNOWLEDGE AS
 you travel life's journey for it is not a heavy burden and will **PROVE OF GREAT VALUE 1234**

6A \$1.75 12a \$1.75 \$3.50 10A \$1.25

Lining Roman No. 40 Italic

STANDARD LINE

JOB FONTS

6-Point 20A \$0.85 50a \$1.15 \$2.00
A ZEPHYR FROM THE SYLVAN
 Glade found its way to the heated city where it was joyfully welcomed by rich and poor alike. #1234567

8-Point 16A \$0.95 44a \$1.30 \$2.25
CONSIDER THE POSTAGE
 Stamp. Its usefulness consists of the ability to stick to one thing until it gets there. My son 12

10-Point 16A \$1.15 40a \$1.35 \$2.50
THE TYPOGRAPHIC
 Displays by leading printers educates their customers and increases sales 12

12-Point 14A \$1.25 32a \$1.50 \$2.75
HANSENCASTS ALL
 Quads and spaces without any nicks. Great improvement over the 21



CASLON OLD STYLE No. 1

This face is the original light face Caslon with regular descenders. Put on special line to preserve style of face.

25 pounds and multiples 14-Point 47c. per lb.

THE PLANTIN MUSEUM IS THE RESIDENCE AND PRINTING-OFFICE
Of one of the early typographers, a gentleman named Plantin, who was the personal
friend of Reubens. Some two hundred years ago Moretus, one of Plantin's successors,
made over the establishment to the municipality, who have since preserved it in its
original state. There is the printing office to be seen as it existed a couple of centuries ago. The
ABCDEFGHIJKLMN^{OP}QRSTU^{VW}XYZ& abcdefghijklmnopqrstu^{vw}xyz

Lower case a to z 11½ ems

25 pounds and multiples 6-Point 76c. per lb.

THE PLANTIN MUSEUM IS THE RESIDENCE AND PRINTING-OFFICE
of one of the early typographers, a gentleman named Plantin, who was the personal
friend of Reubens. Some two hundred years ago Moretus, one of Plantin's suc-
cessors, made over the establishment to the municipality, who have since preserved
it in its original state. There is to be seen the printing-office as it existed a couple
of centuries ago. The most surprising feature is the modern look of the portions of
the building devoted to the setting of type and the imposition and printing. The
caseroom looks as if the compositors had just laid down their "sticks" and gone to
dinner. The slips of copy are to be seen, and certain well-marked proofs, ready
for correction, attest that the old-day typographer was no more free from error than
is the printer of today. In connection with the house there is a delightful court-
yard, two old libraries, and some furniture, so old and beautiful as to defy descrip-
tion. In certain of the rooms are priceless manuscripts and prints, numerous wood-
cut blocks, designs for title pages, and a great array of other interesting things, not
forgetting some fine portraits by Reubens. A week could be spent profitably in the

ABCDEFGHIJKLMN^{OP}QRSTU^{VW}XYZ&

Lower case a to z 13½ ems

abcdefghijklmnopqrstu^{vw}xyz

12345 67890

25 pounds and multiples 8-Point 62c. per lb.

THE PLANTIN MUSEUM IS THE PRINTING-OFFICE AND
Residence of one of the early typographers, a gentleman named Plantin, who
was the personal friend of Reubens. Some two hundred years ago Moretus,
one of Plantin's successors, made over the establishment to the municipality,
which has since preserved it in its original state. There is the printing-office
to be seen as it existed a couple of centuries ago. The most surprising fea-
ture is the modern look of the portions of the building devoted to the setting
of type and the imposing and printing. The caseroom looks as if the com-
positors had just laid down their "sticks" and gone to dinner. The slips of
*copy are to be seen, and certain well marked proofs, ready for correction, attest
that the old-day typographer was no more free from error than is the printer*

ABCDEFGHIJKLMN^{OP}QRSTU^{VW}XYZ&

Lower case a to z 10½ ems

abcdefghijklmnopqrstu^{vw}xyz

12345 67890

25 pounds and multiples 10-Point 54c. per lb.

THE PLANTIN MUSEUM IN ANTWERP IS THE
Printing-office and residence of one of the early typographers,
a gentleman named Plantin, who was the personal friend of
Reubens. Some two hundred years ago Moretus, one of
Plantin's successors, made over the establishment to the mu-
nicipality, who have preserved it in its original state. There is
to be seen the printing-office as it existed a couple of centuries
*ago. The most surprising feature is the modern look of the
portions of the building devoted to the setting of type and im-*

ABCDEFGHIJKLMN^{OP}QRSTU^{VW}XYZ&

Lower case a to z 10½ ems

abcdefghijklmnopqrstu^{vw}xyz

12345 67890

25 pounds and multiples 12-Point 50c. per lb.

THE PLANTIN MUSEUM IS THE
Residence and printing-office of one of the early
typographers, a gentleman named Plantin, who
was the personal friend of Reubens. Some two
hundred years ago Moretus, who was one of
Plantin's successors, made over the establishment
to the municipality, who have since preserved it in

ABCDEFGHIJKLMN^{OP}QRSTU^{VW}XY

Lower case a to z 11½ ems

12345 abcdefghijklmnopqrstu^{vw}xyz 67890

25 pounds and multiples 16-Point 47c. per lb.

THE PLANTIN MUSEUM IS THE PRINTING-OFFICE AND
Residence of one of the early typographers, a gentleman named Plantin,
who was the personal friend of Reubens. Some two hundred years ago
Moretus, one of Plantin's successors, made over the establishment to the
municipality, who have since preserved it in its original state. There is
to be seen the printing-office as it existed a couple of centuries ago. The most

ABCDEFGHIJKLMN^{OP}QRSTU^{VW}XYZ&

Lower case a to z 12 ems

12345 abcdefghijklmnopqrstu^{vw}xyz 67890

THE H. C. HANSEN TYPE FOUNDRY



CASLON OLD STYLE NO. 2

STANDARD LINE

25 pounds and multiples

6-Point

76c. per lb.

25 pounds and multiples

8-Point

62c. per lb.

SUGGESTIONS FOR THE JOB COMPOSITOR

The practice that is in vogue in many job printing offices of having jobs designed and laid out before placing in the hands of the job compositor, thus depriving him of his most glorious labor, is suggestive that there may be something wrong with the working methods of job compositors as a whole, though some contend that it is a step forward in the onward march of progress in printerdom. Observation warrants the assertion, however, that it is practiced merely on account of the economy of the method. A gigantic effort is being made to reduce operating expenses in the composing room.

The job compositor who has a thought for his employer's profits will, in the absence of definite instructions, set a job as simply and effectively as possible. Note how simple in design and construction are many of the best and most up-to-date specimens of job printing. Compare these with those upon which a wealth of labor has been expended, and it will, no doubt, dawn upon you how unnecessary and costly much of the latter is. Do away with the idea that a job in order to be artistic must be laborious. In the general run of work the less labored the job the more artistic and pleasing, providing it displays the handwork of a student of his art, and the more profitable it is to the employer. If, after you have designed a job, you find that it is more or less complicated and much time would be consumed in the composition, try some plan whereby as pleasing effects can be obtained by simpler methods to save time. The compositor who plans to save time rather than to expend it in an unnecessary manner is the man most appreciated and the man whose position is permanent. The composing room is the one place in printing offices where time savers are urgently needed.

You can sketch out an elaborate design with comparative ease, which, to put in type, would mean an amount of labor which the average customer is much opposed to paying for. The compositor who thinks quickest, who is practical as well as artistic, who hits the bull's-eye oftentimes with the least labor is the most successful.

The most artistic printing is of simple design, but simplicity does not necessarily mean severe plainness, but the effective arrangement of types, borders, etc., so as to avoid the expenditure of an unnecessary amount of time in

ABCDEFGHIJKLMNQRSTUUVWXYZ&

Lower case a to z 13 1/4 ems

12345

abcdefghijklmnopqrstuvwxyz

67890

25 pounds and multiples

10-Point

64c. per lb.

SUGGESTIONS FOR JOB COMPOSITORS

The practice that is in vogue in many job printing offices of having jobs designed and laid out before placing in the hands of the job compositor, thus depriving him of his most glorious labor, is suggestive that there may be something wrong with the working methods of job compositors as a whole, though some contend that it is a step forward in the onward march of progress in printerdom. Observation warrants the assertion, however, that it is practiced merely on account of the economy of the method. A gigantic effort is being made to reduce operating expenses in the composing room.

The job compositor who has a thought for his employer's profits will, in the absence of definite instructions, set a job as simply and effectively as possible. Notice how simple in design and construction are many of the best and most up-to-date specimens of job printing. Compare these with those upon which a wealth of labor has been expended, and it will

ABCDEFGHIJKLMNQRSTUUVWXYZ

Lower case a to z 12 1/2 ems

12345

abcdefghijklmnopqrstuvwxyz

67890

SUGGESTIONS FOR JOB COMPOSITORS

The practice that is in vogue in many job printing offices of having jobs designed and laid out before placing in the hands of the job compositor, thus depriving him of his most glorious labor, is suggestive that there may be something wrong with the working methods of job compositors as a whole, though some contend that it is but a step forward in the onward march of progress in printerdom. Observation warrants the assertion, however, that it is practiced merely on account of the economy of the method. A gigantic effort is being made to reduce operating expenses in the composing room.

The job compositor who has a thought for his employer's profits will, in the absence of definite instructions, set a job as simply and effectively as possible. Note how simple in design and construction are many of the best and most up-to-date specimens of job printing. Compare these with those upon which a wealth of labor has been expended and it will, no doubt, dawn upon you how unnecessary and costly much of the latter is. Do away with the idea that a job in order to be artistic must be laborious. In the general run of work the less labored the job the more artistic and pleasing, providing it displays the handwork of a student of his art, and the more profitable it is to the employer. If, after you have designed a job, you find that it is more or less complicated and much time would be consumed in the composition, try some plan whereby as pleasing effects can

ABCDEFGHIJKLMNQRSTUUVWXYZ&

Lower case a to z 13 ems

12345

abcdefghijklmnopqrstuvwxyz

67890

25 pounds and multiples

12-Point

50c. per lb.

PRACTICAL SUGGESTIONS

The practice that is in vogue in many job printing offices of having jobs designed and laid out before placing in the hands of the job compositor, thus depriving him of his most glorious labor, is suggestive that there may be something wrong with the working methods of job compositors as a whole, though some contend that it is a step forward in the onward march of printerdom. Observation warrants the assertion, however, that it is practiced merely on account of the economy of the method.

A job compositor who has a thought for his employer's profits will, in the absence of definite instructions, set a job as simply and

ABCDEFGHIJKLMNQRSTUW

Lower case a to z 13 ems

123

abcdefghijklmnopqrstuvwxyz

456

THE H. C. HANSEN TYPE FOUNDRY

CASLON OLD STYLE No. 2

STANDARD LINE

25 pounds and multiples

14-Point

47c. per lb.

25 pounds and multiples

18-Point

47c. per lb.

A PRACTICAL SUGGESTION

The practice that is in vogue in many job printing offices of having jobs designed and laid out before placing in the hands of the job compositor, depriving him of his most glorious labor, is suggestive that there is something wrong with the working methods of job compositors as a whole, though some contend that it is a step forward in the onward march of printerdom. Observation warrants the assertion, *however, that it is practiced merely on account of the economy of the method.* 68

ABCDEFGHIJKLMNQRST

Lower case a to z 13 ems

3 abcdefghijklmnopqrstuvwxyz 5

TIMELY SUGGESTION

The practice now in vogue in many job printing offices of having jobs designed and laid out before placing in the hands of the job compositor, thus depriving him of his most glorious labor, is suggestive that there may *be something wrong with the working methods of compositors*

ABCDEFGHIJKLMNOST

Lower case a to z 12½ ems

abcdefghijklmnopqrstuvw

25 pounds and multiples

24-Point

47c. per lb.

SUGGESTIONS FOR COMPOSITORS

The practice that is in vogue in many job printing offices of having jobs designed and laid out before placing in the hands of the job compositor, thus depriving him of his most glorious labor, is suggestive that there may be something wrong with the working methods of compositors as a whole, though *some contend that it is a step forward in the*

Lower case a to z 13 ems

1234 abcdefghijklmnopqrstuvwxyz 5678

THE H. C. HANSEN TYPE FOUNDRY



LINING CASLON FULL FACE

Standard Line

25 pounds and multiples 6-Point 76c. per lb.

EVEN IN THE ART OF PRINTING, PROGRESS THOUGH Continuous, was exceedingly slow for three hundred and fifty years, and although the volume of printed matter has increased much more rapidly during the last half century, responsive to the conditions of our age, the use of printing is still very largely a matter of habit and education, varying widely in different nations, and even among the states of our own Republic. This fact is illustrated by the expenditures of state governments for official printing, which show differences so great as to be explainable only by the habit of the sparing or of the liberal use of printed matter. The state of New York, for example, has long been foremost among all the states in the production of printing; in 1900 the state government expended \$654,330.53 for official printing, while the state officials of Tennessee, a state in which printing is a minor industry and much less a factor in daily life, expended in the same year but \$8,136.38. The proportion, therefore, of official printing to population was twenty times as great in New York as in Tennessee. On the whole, however, the advance of the United States during the last fifty years, which may be set as the period of greatest industrial activity, has been so great and far reaching as to place the industry among the leaders, and to arouse some curiosity concerning the part which the printer has played in this half century competition among the great industries. Fortunately it is possible to measure, approximately at least, the progress which the principal industries in the United States have made since 1850, for the federal census, taken in that year, and commonly regarded as the first modern census, included statistics of manufacturers. The results,

ABCDEFGHIJKLMN**OPQRST**UVWXYZ&
\$12345 abcdefghijklmnopqrstuvwx**yz** 67890

25 pounds and multiples 10-Point 54c. per lb.

EVEN IN ART OF PRINTING, Progress, though continuous was slow for three hundred and fifty years, and although the volume of printed matter has increased much more rapidly during the last half century, responsive to the conditions of our age, the use of printing is still largely a matter of habit and education varying widely in different nations and even among the states of our Republic. This fact is illustrated by the expenditures of state governments for official printing, which show differences so great as to be explainable only by the habit of the sparing or of the liberal use of printed matter. The state of New York, for example, has long been foremost among all the states in the production of printing; in 1900 the state

ABCDEFGHIJKLMN**OPQRST**UVWXYZ
\$123 abcdefghijklmnopqrstuvwx**yz** 5780

ALL HANSEN TYPE CAST FROM SUPERIOR COPPER ALLOY METAL

25 pounds and multiples 8-Point 62c. per lb.

EVEN IN THE ART OF PRINTING, PROGRESS Though continuous, was exceedingly slow for three hundred and fifty years, and, although the volume of printed matter has increased much more rapidly during the last half century, responsive to the conditions of our age, the use of printing is still largely a matter of habit and education, varying widely in different nations, and even among the states of our own Republic. This fact is illustrated by the expenditures of the state governments for official printing, which show differences so great as to be explainable only by the habit of the sparing or of the liberal use of printed matter. The state of New York, for example, has long been foremost among all the states in the production of printing; in 1900 the state government expended \$654,330.53 for official printing, while the state of Tennessee, a state in which printing is a minor industry and much less a factor in daily life, expended in the same year but \$8,136.38. The proportion there-

fore, of official printing to population was twenty times as great in New York as in Tennessee. On the whole, however, the ad-

ABCDEFGHIJKLMN**OPQRST**UVWX
\$12 abcdefghijklmnopqrstuvwx**yz** 467

25 pounds and multiples 12-Point 50c. per lb.

EVEN IN THE ART OF Printing, progress, though continuous, was slow for three hundred and fifty years, and although the volume of printed matter has increased much more rapidly during the last half century, responsive to the conditions of our age, the use of printing is still largely a matter of habit and education, varying widely in different nations and among the various states of our own Republic. This fact is illustrated by the expenditures of the state governments for official printing which show differences so great as to be explainable

ABCDEFGHIJKLMN**OPQRST**UW
12 abcdefghijklmnopqrstuvwx**yz** 89

ALL HANSEN TYPE IS CUT EXTRA DEEP INSURING LONG LIFE AND DURABILITY

JOB FONTS

6-Point		
22A \$0.95	44a \$1.05	\$2.00
8-Point		
19A \$1.10	38a \$1.15	\$2.25
10-Point		
16A \$1.20	32a \$1.30	\$2.50
12-Point		
16A \$1.30	32a \$1.45	\$2.75
Cast to 48-PT. See p. 45		



LINING VIKING OLD STYLE No. 3

Standard Line

25 pounds and multiples 6-Point 76c. per lb.

A REPUTATION FOR PROMPTNESS IS ONE OF THE THINGS That a printer should strive for. He will have gained a great advantage when it comes to be said of him that he always gets work out on time, and it will pay him to endeavor to secure such a reputation by every means in his power. I know how prone is the ordinary business man to wait until he is clean out of stationery, or whatever he wants, before ordering more, or to postpone until the latest possible moment the order for circulars, handbills or any bit of commercial work; and then, when he does give you the order, he acts as though he thought his was the only work you had in your shop, that you should give him immediate precedence over everybody else.

If your office is run systematically, you can tell after a moment's reflection just how the work is getting on, and what chances there are for getting a new job started in. Then you can tell your customer when he can have his work, within an hour or two, unless it is a job of considerable magnitude. Then if he says that is too late, tell him you are sorry, but you would rather lose the order than disappoint him in the delivery of it. Explain the situation fully to him, and it is ten chances to one he will leave the order.

If he does so, you must have that work ready when it is promised. One failure to keep your word in this respect will do you incalculable harm. Don't promise it a minute earlier than you have it ready, but never let the appointed hour go by without delivering the work.

So much for building up reputation. You will have to help spread that reputation yourself by telling about it in your advertising. The adoption of a "catch line" or "trade motto" is just as good for a printer's advertising as for that of any other man. "Ready when you want it," or "If it isn't done when promised, don't take it," or "Done on time and done right." Such a phrase, if adopted, should be used on every piece of advertising the office uses,

ABCDEFGHIJKLMN OPQRSTUVWXYZ&

12345 abcdefghijklmnopqrstuvwxyz 67890

25 pounds and multiples 10-Point 54c. per lb.

A REPUTATION FOR PROMPTNESS IS One thing that a job printer should strive for. He will have gained a great advantage when it comes to be said of him that he always gets work out on time, and it will pay him to endeavor to secure such a reputation by every means in his power. I know how prone is the ordinary business man to wait until he is clean out of stationery, or whatever he wants, before ordering more, or to postpone until the last possible moment the order for circulars, or handbills, or any other bit of commercial work; and then, when he does give you the order, he acts as though he thought his was the only work you had in your shop—that you should immediately give him precedence over everybody else.

If your office is run systematically, you can tell, after a moment's reflection just how the work is getting on, and what chances there are

ABCDEFGHIJKLMN OPQRSTUVWXYZ&

12345 abcdefghijklmnopqrstuvwxyz 67890

25 pounds and multiples 8-Point 62c. per lb.

A REPUTATION FOR PROMPTNESS IS ONE OF THE Things that a job printer should strive for. He will have gained a great advantage when it comes to be said of him that he always gets work out on time, and it will pay him to endeavor to secure such a reputation by every means in his power. I know how prone is the ordinary business man to wait until he is clean out of stationery, or whatever he wants, before ordering more, or to postpone until the latest possible moment the order for circulars, or handbills, or any other bit of commercial work; and then, when he does give you the order, he acts as though he thought his was the only work you had in your shop—that you should immediately give him precedence over everybody else.

If your office is run systematically, you can tell after a moment's reflection just how the work is getting on, and what chances there are for getting a new job started in. Then you can tell your customer when he can have his work, within an hour or two, unless it is a job of considerable magnitude. Then if he says that is too late, tell him you are sorry, but you would rather lose the order than disappoint him in the delivery of it. Explain the situation fully to him, and it is ten chances to one he will leave the order. If he does so, you must have that work ready

ABCDEFGHIJKLMN OPQRSTUVWXYZ&

12345 abcdefghijklmnopqrstuvwxyz 67890

25 pounds and multiples 12-Point 60c. per lb.

REPUTATION FOR PROMPTNESS Is the one thing that a job printer should strive for. He will have gained a great advantage when it comes to be said of him that he invariably gets work out on time, and it will pay him to endeavor to secure such a reputation by every means in his power. I know how prone the ordinary business man is to wait until he is clean out of stationery, or whatever he wants, before ordering more, or to postpone until the latest possible moment the order for circulars, or handbills, or any other bit of commercial work; and then, when he does give you the order he acts as though

ABCDEFGHIJKLMN OPQRSTUVWXYZ

123 abcdefghijklmnopqrstuvwxyz 890



THE HUNNEWELL SERIES

Standard Line

25 pounds and multiples

6-Point

76c. per lb.

EVEN IN THE ART OF PRINTING, PROGRESS THOUGH Continuous, was exceedingly slow for three hundred and fifty years, and although the volume of printed matter has increased much more rapidly during the last half century, responsive to the conditions of our age, the use of printing is still very largely a matter of habit and education, varying widely in different nations, and even among the various states of our own Republic. This fact is illustrated by the expenditures of state governments for official printing, which show differences so great as to be explainable only by the habit of the sparing or of the liberal use of printed matter. The state of New York, for example, has long been foremost among all the states in the production of printing; in 1900 the state government expended \$654,330.53 for official printing, while state officials of Tennessee, a state in which printing is a minor industry and much less a factor in daily life, expended in the same year but \$8,136.38. The proportion, therefore, of official printing to population was twenty times as great in New York as in Tennessee. On the whole, however, the advance of the United States during the last fifty years, which may be set as the period of greatest industrial activity, has been so great and far reaching as to place the industry among the leaders, and to arouse some curiosity concerning the part which the printer has played in this half century competition among the great industries. Fortunately it is possible to measure, approximately at least, the progress which the principal industries in the United States have made since 1850, for the federal census taken in that year, and commonly regarded as the first modern census, included statistics of manufacturers. The results, however, cannot be regarded as entirely accurate. Invention, expansion, and progress have wrought so mightily in the half century since 1860 that a statistical bottom firm enough to hold anchor would be especially welcome, but methods of enumeration and form*** The Printing Art

ABCDEFGHIJKLMNPOQRSTUVWXYZ&

\$12345

abcdefghijklmnpqrstuvwxy

67890

25 pounds and multiples

8-Point

62c. per lb.

EVEN IN THE ART OF PRINTING, PROGRESS Though continuous, was exceedingly slow for three hundred and fifty years, and, although the volume of printed matter has increased much more rapidly during the last half century, responsive to the conditions of our age, the use of printing is still largely a matter of habit and education, varying widely in different nations, and even among the various states of our own Republic. This fact is illustrated by the expenditures of state governments for official printing, which show differences so great as to be explainable only by the habit of the sparing or of the liberal use of printed matter. The state of New York, for example, has long been foremost among all the states in the production of printing; in 1900 the state government expended \$654,330.53 for official printing, while the state of Tennessee, a state in which printing is a minor industry and much less a factor in daily life, expended in the same year but \$8,136.38. The proportion, therefore, of official printing to population was twenty times as great in New York as in Tennessee. On the whole, however, the advance of the printing industry in the United States during the last fifty years, which may be set as the period of greatest industrial activity, has been so great as to place the industry among the leaders, and to arouse some curiosity 4567

ABCDEFGHIJKLMNPOQRSTUVWXYZ&

\$12345

abcdefghijklmnpqrstuvwxy

67890

Wood Goods and Machinery Section of this Specimen Book set in Hunnewell

25 pounds and multiples

10-Point

54c. per lb.

EVEN IN THE ART OF PRINTING, Progress, though continuous, was very slow for three hundred and fifty years, and, although the volume of printed matter has increased much more rapidly during the last half century, responsive to the conditions of our age, the use of printing is still largely a matter of habit and education, varying widely in different nations, and even among the various states of our own Republic. This fact is illustrated by the expenditures of the state governments for official printing, which show differences so great as to be explainable only by the habit of the sparing or of the liberal use of printed matter. The state of New York, for example, has long been foremost among all the states in the production of printing; in 1900 the state government expended \$654,330.53 for official printing, while the state of Tennessee, a state in which 123

ABCDEFGHIJKLMNPOQRSTUVWXYZ
\$12345 abcdefghijklmnpqrstuvwxy 57890

25 pounds and multiples

12-Point

50c. per lb.

EVEN IN THE ART OF PRINTING The progress, though continuous, was exceedingly slow for three hundred and fifty years, and, although the volume of printed matter has increased much more rapidly during the last half century, responsive to the conditions of our age, the use of printing is still largely a matter of habit and education, varying widely in different nations, and even among the states of our own Republic. This fact is illustrated by the expenditures of the state governments for official printing, which show differences so great as to be explainable only by the habit of the sparing or of the liberal use of printed matter. The state of 12

ABCDEFGHIJKLMNPOQRSTUVWXYZ
12345 abcdefghijklmnpqrstuvwxy 67890

Opened with 2-Point Leads

THE H. C. HANSEN TYPE FOUNDRY



LINING FRENCH OLD STYLE No. 3

Standard Line

25 pounds and multiples 6-Point 76c. per lb.

EVEN IN THE ART OF PRINTING, THE PROGRESS, THOUGH Continuous, was exceedingly slow for three hundred and fifty years, and although the volume of printed matter has increased much more rapidly during the last half century, responsive to the conditions of our age, the use of printing is still very largely a matter of habit and education, varying widely in different nations, and even among the various states of our own Republic. This fact is illustrated by the expenditures of state governments for official printing, which show differences so great as to be explainable only by the habit of the sparing or of the liberal use of printed matter. The state of New York, for example, has long been foremost among all the states in the production of printing; in 1900 the state government expended \$654,330.53 for official printing, while the state officials of Tennessee, a state in which printing is a minor industry and much less a factor in daily life, expended in the same year but \$5,136.38. The proportion, therefore, of official printing to population was twenty times as great in New York as in Tennessee. On the whole, however, the advance of the United States during the last fifty years, which may be set as the period of greatest industrial activity, has been so great and far reaching as to place the industry among the leaders, and to arouse some curiosity concerning the part which the printer has played in this half century competition among the great industries. Fortunately it is possible to measure, approximately at least, the progress which the principal industries in the United States have made since 1850, for the federal census taken in that year, and commonly regarded as the first modern census, included statistics of manufactures. The results, however, cannot be regarded as entirely accurate. Invention, expansion and progress have wrought so mightily in the half century since 1850 that a statistical bottom firm enough to hold anchor would be especially welcome, but methods of enumeration and form of inquiry have ***—The Printing Art

ABCDEFGHIJKLMN OPQRSTUVWXYZ &
 abcdefghijklmnopqrstuvwxyz

25 pounds and multiples 8-Point 62c. per lb.

EVEN IN THE ART OF PRINTING, PROGRESS Though continuous, was exceedingly slow for three hundred and fifty years, and, although the volume of printed matter has increased much more rapidly during the last half century, responsive to the conditions of our age, the use of printing is still largely a matter of habit and education, varying widely in different nations, and even among the different states of our own Republic. This fact is illustrated by the expenditures of state governments for official printing, which show differences so great as to be explainable only by the habit of the sparing or of the liberal use of printed matter. The state of New York, for example, has long been foremost among all the states in the production of printing; in 1900 the state government expended \$654,330.53 for official printing, while the state of Tennessee, a state in which printing is a minor industry and much less a factor in daily life, expended in the same year but \$8,136.38. The proportion, therefore, of official printing to population was twenty times as great in New York as in Tennessee. On the whole, however, the advance of the printing industry in the United States during the last fifty years, which may be set as the period of greatest industrial activity, has been so great as to place

ABCDEFGHIJKLMN OPQRSTUVWXYZ &
 abcdefghijklmnopqrstuvwxyz

25 pounds and multiples 10-Point 54c. per lb.

EVEN IN THE ART OF PRINTING, PROGRESS Though continuous, was exceedingly slow for three hundred and fifty years, and although the volume of printed matter has increased much more rapidly during the last half century, responsive to the conditions of our age, the use of printing is still largely a matter of habit and education, varying widely in different nations, and even among the various states of our own Republic. This fact is illustrated by the expenditures of state governments for official printing, which show differences so great as to be explainable only by the habit of the sparing or of the liberal use of printed matter. The state of New York, for example, has long been foremost among all the states in the production of printing; in 1900 the state government expended \$654,330.53 for official printing, while the state of Tennessee, a state in which printing is a minor industry and much less a factor in daily life, expended in the same

ABCDEFGHIJKLMN OPQRSTUVWXYZ &
 abcdefghijklmnopqrstuvwxyz

25 pounds and multiples 12-point 50c. per lb.

EVEN IN THE ART OF PRINTING, The progress, though continuous, was exceedingly slow for three hundred and fifty years, and, although the volume of printed matter has increased much more rapidly during the last half century, responsive to the conditions of our age, the use of printing is still largely a matter of habit and education, varying widely in different nations, and even among the various states of our own Republic. This fact is illustrated by the expenditures of the state governments for official printing which show differences so great as to be explainable only by the habit of the sparing or of the liberal use of printed matter.

ABCDEFGHIJKLMN OPQRSTUVWXYZ &
 abcdefghijklmnopqrstuvwxyz

Opened with 2-Point Leads

THE H. C. HANSEN TYPE FOUNDRY



CHINESE PHILOSOPHY

A conjurer and a tailor once happened to converse together. "Alas!" cries the tailor, "what an unhappy poor creature am I; if people should ever take it in their heads to live without clothes I am undone; I have no other trade to have recourse to." "Indeed, friend, I pity you sincerely," replies the conjurer; "but, thank Heaven, things are not quite so bad with me; for if one trick should fail, I have an hundred tricks more for them yet. However, if at any time you are reduced to beggary, apply to me, and I will relieve you." A famine overspread the land; the tailor made a shift to live, because his customers could not buy clothes; but the poor conjurer, with all his tricks, could find none that had money to buy them; it was in vain that he promised to eat figs and fig-pins; no single creature would relieve him; he was obliged to beg from the very tailor whom he had formerly despised.

There are no obstructions more fatal to a man's pride and repentment. If you must repent, all, at least suppress your indignation until you come rich, and then shew away: the repentance of a poor man is like the efforts of a harmless insect; it may get him crushed, but cannot hurt him. Who values that anger which is consumed by empty menaces.

Once upon a time, a goose fed its young on the side; and a goose, in such circumstances

15 A \$1.50 30a \$1.75 \$3.25 Small Caps, 10A \$0.60
Poster Font, approx. 25 lbs., \$16.50

6-Pt. Swastika Border No. 1 60 inches \$1.50

Originated and cast by
THE H. C. HANSEN TYPE FOUNDRY
190-192 Congress Street, Boston
43 Centre Street, New York

FOURTEENTH CENTURY

12-POINT

ABCDEFGHIJK
LMNOPQRSTU
VWXYZV

\$1234567890

ABCDEFGHIJKLMN
OPQRSTUVWXYZ

abcdefghijklmnop
qrstuvwxyz

ff fi fl ct th si fl st

Superior Letters

H d e h r s t

Y^c TRUE NARRATIVE
of
SIR ALGERNON STANHOPE'S
ADVENTURES

How y^c ladd^e of tender years
did battle with y^c bold^e
highwayman

By EDWARD WELLER



Printers' Joy No 11 10c

3rd Edition

DAN'L HOWLAND & SON
LONDON

12-Pt. Border No. 155 54 inches \$1.50



CASLON OLD STYLE No. 1. JOB FONTS

ORIGINAL CASLON WITH REGULAR DESCENDERS

PUT ON SPECIAL LINE TO PRESERVE STYLE OF FACE

6-Point 25A \$0.80 70a \$1.20 \$2.00
 "WELL! WHY SHOULDN'T HE DO GOOD WORK WHEN HE HAS All the latest type faces to work with!" Thus spoke Morpheus Grumble of his more successful fellow workman employed by a rival firm, Doitt, Wright & Co., whose work bore the reputation of being the very best that could be produced

8-Point 20A \$1.00 50a \$1.25 \$2.25
 NOW, THE TRUTH BE KNOWN, THE FIRM BY WHOM Morpheus was employed was well equipped to produce good printing, but Morpheus followed the line of least resistance and performed his work in a half-hearted, indolent manner, studying the face of the clock, while his

10-Point 18A \$1.10 45a \$1.40 \$2.50
 FRIEND AT DOITT, WRIGHT & CO.'S STUDIED the possibilities of each border, ornament, and face of type in the office and carefully perused the various trade journals, not omitting the advertisements, gleaning therefrom many helpful

12-Point 16A \$1.25 35a \$1.50 \$2.75
 IDEAS WHICH HE STORED AWAY In the recesses of his brain to be brought forth and put to practical use when the proper job

14-Point 12A \$1.40 90a \$1.60 \$3.00
 THE PRIEST WAS SINGING AND The organ sounded, and then anon the great cathedral bell. It was the elevation

16-Point 12A \$1.75 22a \$1.50 \$3.25
 MANY COMPOSITORS SAY "I can't" when confronted with a difficult bit of copy. Buck up!

THOMAS J. GRAYLE
President
 E. FRANK WILKINS
Vice-President
 DAVID W. GRAYLE
Sec'y-Treas.

GRAYLE BOOK COMPANY
 SCHOOL AND COLLEGE TEXT-BOOKS
 SCIENTIFIC WORKS - BIOGRAPHIES

BRANCH OFFICES
 NEW YORK
 BOSTON ATLANTA
 PHILADELPHIA
 SAN FRANCISCO
 CHICAGO



Cambridge, Mass.

Lining Ronaldson Extended No. 3

STANDARD LINE

6-Point 17A \$0.90 34a \$1.10 \$2.00
 STRATFORD-ON-AVON HAS THE PROUD Distinction of being the birthplace of William Shakespeare, and the house in which the great poet was born and spent his earlier years still stands on Henley street. As years passed by it underwent many changes, but its appearance now is doubtless not materially different from what it was in the latter part of the sixteenth century, since it has been carefully preserved as a national memorial to the poet. There are

8-Point 14A \$1.00 28a \$1.25 \$2.25
 STRATFORD-ON-AVON HAS THE Proud distinction of being the birthplace of William Shakespeare, and the house in which the great poet was born still stands on Henley street. As years passed by it doubtless underwent changes but its appearance now is doubtless not materially different from what it was in the latter part of

10-Point 18A \$1.10 26a \$1.40 \$2.50
 STRATFORD-ON-AVON HAS The proud distinction of being the birthplace of William Shakespeare, and the house in which the great poet was born is still standing on Henley street. As years passed it doubtless under-

12-Point 11A \$1.20 23a \$1.55 \$2.75
 STRATFORD-ON-AVON IS The birthplace of William Shakespeare, and the house in which he was born still stands on Henley street. It underwent many changes as the years passed by, the

THE H. C. HANSEN TYPE FOUNDRY



German Boldface

6-Point

12A \$0.85 36a \$1.15 \$2.00

Die Schrift, die Uebertragung des Gedankens und des Wortes, ist zugleich die wichtigste Trägerin aller Kultur und Wissenschaft; sie ist das geistige Band, welches schon in den ältesten Zeiten die großen Geister mit den Menschen in enge Beziehung brachte, bis Johann Gutenberg durch die segensreiche Erfindung der Druckschrift jene hellstrahlende Lichtquelle geschaffen hat, unter deren Einfluß sich das geistige Leben des Mittelalters zu so ungeahuter Höhe emporhob; jene Lichtquelle, die noch heute in stets zunehmender Fülle allen Gebieten menschlichen Schaffens und dem internationalen Betriebe der Nationen zuguthommt. Es giebt in den Kreisen der gebildeten Welt keine Lebensstellung, die nicht zur Schrift in naher Beziehung stände

8-Point

13A \$1.05 32a \$1.20 \$2.25

Die Schrift, die Uebertragung des Gedankens und des Wortes, ist zugleich die wichtigste Trägerin aller Kultur und Wissenschaft; sie ist das geistige Band, welches schon in den ältesten Zeiten die großen Geister mit den Menschen in enge Beziehung brachte, bis Johann Gutenberg durch die segensreiche Erfindung der Druckschrift jene hellstrahlende Lichtquelle, geschaffen hat, unter deren Einfluß sich das geistige Leben des Mittelalters zu so

**Programm
der Fachklasse für
Typographen**



**Der 1. Handwerkerschule
Berlin, Lindenstraße**



9-Point

12A \$1.10 34a \$1.40 \$2.50

Die Schrift, die Uebertragung des Gedankens und des Wortes, ist zugleich die wichtigste Trägerin aller Kultur und Wissenschaft; sie ist das geistige Band, welches schon in den ältesten Zeiten die großen Geister mit den Menschen in enge Beziehung brachte, bis Johann Gutenberg durch die segensreiche Erfindung der Druckschrift jene hellstrahlende Lichtquelle geschaffen hat, unter deren Einfluß sich das geistige Leben des

10-Point

10A \$1.00 30a \$1.50 \$2.50

Die Schrift, die Uebertragung des Gedankens und des Wortes, ist zugleich die wichtigste Trägerin aller Kultur und Wissenschaft; sie ist das geistige Band, welches schon in den ältesten Zeiten die großen Geister mit den Menschen in enge Beziehung brachte, bis Johann Gutenberg durch die segensreiche Erfindung der Druckschrift jene hel-

Characters in founts of all sizes

ABCDEFGHIJKLMN O PQRSTU VW
 12345 X Y Z 67890
 abcdefghijklmnopqrzstuvwxyz
 & A B C ä ö ü ç & U ff fi fl fi ft B b

12-Point

10A \$1.25 28a \$1.70 \$2.75

Die Schrift, die Uebertragung des Gedankens und des Wortes, ist zugleich die wichtigste Trägerin aller Kultur und Wissenschaft; sie ist das geistige Band, welches schon von ältester Zeit die großen Geister mit den Menschen in enge Beziehung gebracht hat, bis Johann Gutenberg durch 7

18-Point

6A \$1.25 15a \$2.00 \$3.25

Die Schrift, die Uebertragung des Gedankens und des Wortes, ist zugleich die wichtigste Trägerin aller Kultur und Wissenschaft; sie ist das geistige Band, welches schon in den

THE H. C. HANSEN TYPE FOUNDRY



German Text

6-Point 14A \$0.85 42a \$1.15 \$2.00

Der Erste, welcher die Malerei und Poesie mit einander verglich, war ein Mann von feinem Gefühle, der von beiden Künsten eine ähnliche Wirkung auf sich verspürte. Beide, empfand er, stellen uns abwesende Dinge als gegenwärtig, den Schein als Wirklichkeit vor; beide täuschen, und beider Täuschung gefällt. Ein Zweiter suchte in das Innere dieses Gefallens einzudringen und entdeckte, daß es bei beiden aus einerlei Quelle fließe. Die Schönheit, deren Begriff wir zuerst von körperlichen Dingen abziehen, hat allgemeine Regeln, die sich auf mehrere Dinge anwenden lassen; auf Handlungen, auf Gedanken sowohl als auf Formen. Ein Dritter, welcher über den Werth und die Vertheilung dieser allgemeinen Regeln nachdachte, bemerkte, daß einige mehr in der Malerei, andere mehr in der Poesie herrschten; daß also bei diesen die Poesie der Malerei, bei jenen die Malerei der Poesie mit Erläuterungen und Beispielen ausbessern könne. Das erste war der Liebhaber, das zweite der Philosoph, das dritte der Kunsttrichter. Sene beiden konnten nicht leicht, weder von ihrem Gefühl, noch von ihren Schlüssen einen unredhten Gebrauch machen. Bei den Bemerkungen des Kunsttrichters dagegen beruht das Meiste in der Richtigkeit der Anwendung auf den einzelnen

ABCDEFGHIJKLMNOPQRSTUVWXYZ

12345 abcdefghijklmnopqrstuvwxyz 67890

& A D U ä ö ü ç k ll ff fi fl ff si ft ß ð

8-Point 14A \$1.00 40a \$1.25 \$2.25

Der Erste, welcher die Malerei und Poesie mit einander verglich, war ein Mann von feinem Gefühle, welcher von beiden Künsten eine ähnliche Wirkung auf sich verspürte. Beide, empfand er, stellen uns abwesende Dinge als gegenwärtig, den Schein als Wirklichkeit vor; beide täuschen, und beider Täuschung gefällt. Ein Zweiter suchte in das Innere dieses Gefallens einzudringen und entdeckte, daß es bei beiden aus einerlei Quelle fließe. Die Schönheit, deren Begriff wir zuerst von körperlichen Dingen abziehen, hat allgemeine Regeln, die sich auf mehrere Dinge anwenden lassen; auf Handlungen, auf Gedanken sowohl als auf Formen. Ein Dritter, welcher über den Werth und die Vertheilung dieser allgemeinen Regeln nachdachte, bemerkte, daß

ABCDEFGHIJKLMNOPQRSTUVWXYZ

12345 abcdefghijklmnopqrstuvwxyz 67890

& A D U ä ö ü ç k ll ff fi fl ff si ft ß ð

12-Point 10A \$1.10 32a \$1.65 \$2.75

Der Erste, welcher die Malerei und Poesie mit einander verglich, war ein Mann von feinem Gefühle, der von beiden Künsten eine ähnliche Wirkung auf sich verspürte. Beide, empfand er, stellen uns abwesende Dinge als gegenwärtig, den Schein als Wirklichkeit vor; beide täuschen, und beider Täuschung gefällt. Ein Zweiter suchte in das Innere dieses Gefallens einzudringen und entdeckte, daß es bei beiden aus einerlei Quelle fließe. Die Schönheit, deren Begriff wir zuerst von körperlichen Dingen abziehen, hat allgemeine Regeln, die sich auf mehrere Dinge anwenden lassen; auf Handlungen, auf Gedanken sowohl als auf Formen. Ein Dritter, welcher über den Werth und die Vertheilung dieser allgemeinen Regeln nachdachte, bemerkte, daß einige mehr in der Malerei

ABCDEFGHIJKLMNOPQRSTUVWXYZ

12345 abcdefghijklmnopqrstuvwxyz 67890

& A D U ä ö ü ç k ll ff fi fl ff si ft ß ð

9-Point 14A \$1.15 40a \$1.35 \$2.50

Der Erste, welcher die Malerei und Poesie mit einander verglich, war ein Mann von feinem Gefühle, der von beiden Künsten eine ähnliche Wirkung auf sich verspürte. Beide, empfand er, stellen uns abwesende Dinge als gegenwärtig, den Schein als Wirklichkeit vor; beide täuschen, und beider Täuschung gefällt. Ein Zweiter suchte in das Innere dieses Gefallens einzudringen und entdeckte, daß es bei beiden aus einerlei Quelle fließe. Die Schönheit, deren Begriff wir zuerst von körperlichen Dingen abziehen, hat allgemeine Regeln, die sich auf mehrere Dinge anwenden lassen; auf Gedanken sowohl als auf Formen. Ein Dritter, welcher über den Werth und die Vertheilung dieser allgemeinen

ABCDEFGHIJKLMNOPQRSTUVWXYZ

12345 abcdefghijklmnopqrstuvwxyz 67890

& A D U ä ö ü ç k ll ff fi fl ff si ft ß ð

10-Point 10A \$1.00 36a \$1.50 \$2.50

Der Erste, welcher die Malerei und Poesie mit einander verglich, war ein Mann von feinem Gefühle, der von beiden Künsten eine ähnliche Wirkung auf sich verspürte. Beide, empfand er, stellen uns abwesende Dinge als gegenwärtig, den Schein als Wirklichkeit vor; beide täuschen, und beider Täuschung gefällt. Ein Zweiter suchte in das Innere dieses Gefallens einzudringen und entdeckte, daß es bei beiden aus einerlei Quelle fließe. Die Schönheit, deren Begriff wir zuerst von körperlichen Dingen abziehen, hat allgemeine Regeln, die sich auf mehrere Dinge

ABCDEFGHIJKLMNOPQRSTUVWXYZ

12345 abcdefghijklmnopqrstuvwxyz 67890

& A D U ä ö ü ç k ll ff fi fl ff si ft ß ð

Sold also at regular body rates

Other 10-Pt. German Face shown on page 169

THE H. C. HANSEN TYPE FOUNDRY



HANSEN'S NEW IMPROVED LINING LEADERS

STANDARD LINE

Cast to line with all point bodies of lining type from 5-point to 18-point, with a variety of faces, they are the most complete assortment of leaders ever brought out

One Dot to the Em		PER POUND	Three Dots to the Em		PER POUND
5-Point	\$1.20	5-Point	\$1.20
5½-Point	88 cents	5½-Point	88 cents
6-Point	76 cents	6-Point	76 cents
7-Point	66 cents	7-Point	66 cents
8-Point	62 cents	8-Point	62 cents
9-Point	58 cents	9-Point	58 cents
10-Point	54 cents	10-Point	54 cents
11-Point	52 cents	11-Point	52 cents
12-Point	50 cents	12-Point	50 cents
14-Point	47 cents	14-Point	47 cents
16-Point	47 cents	16-Point	47 cents
18-Point	47 cents	18-Point	47 cents
Two Dots to the Em		PER POUND	Fine Round Dot		PER POUND
5-Point	\$1.20	5-Point	\$1.20
5½-Point	88 cents	5½-Point	88 cents
6-Point	76 cents	6-Point	76 cents
7-Point	66 cents	7-Point	66 cents
8-Point	62 cents	8-Point	62 cents
9-Point	58 cents	9-Point	58 cents
10-Point	54 cents	10-Point	54 cents
11-Point	52 cents	11-Point	52 cents
12-Point	50 cents	12-Point	50 cents
14-Point	47 cents	 		
16-Point	47 cents	Characters of One Dot to the Em Lining Leaders		
18-Point	47 cents	All characters shown on 8-Point body		
 			Characters of Two Dots to the Em Lining Leaders		
 			Characters of Three Dots to the Em Lining Leaders		
 			Characters of Fine Round Dot Lining Leaders		

In matching leaders in case be sure and send sample leader. All sizes and faces put up in 3 and 5 pound job fonts at regular body rates as above.

THE H. C. HANSEN TYPE FOUNDRY



HANSEN'S NEW IMPROVED LINING LEADERS

STANDARD LINE

	Hyphen Face	PER POUND
6-Point		76 cents
7-Point		66 cents
8-Point		62 cents
9-Point		58 cents
10-Point		54 cents
11-Point		52 cents
12-Point		50 cents

Characters of Hyphen Face Lining Leaders
Shown on 8-Point body

	Fine Hyphen Face	PER POUND
6-Point		76 cents
7-Point		66 cents
8-Point		62 cents
9-Point		58 cents
10-Point		54 cents
11-Point		52 cents
12-Point		50 cents

Characters of Fine Hyphen Face Lining Leaders
Shown on 8-Point body

Specimen of 12-Point Hyphen Face Lining Leaders aligned with 18-Point and 30-Point Newton Script

\$ _____ *Boston, Mass.,* _____ 190_____

Received of _____

_____ *Dollars*
100

Being the _____ *semi-annual payment on Certificate No.* _____

_____ *Sgt. for the Great Guns Mining Co.*

Specimen of 6-Point Two Dots to the Em Lining Leaders used with Hansen's 6-Point Lining Crawford

Boston in 1776.....	James Byron Masters
The Trial Trip of the Dolphin.....	Charles Seaman
The Resolution of Sammy.....	George Custer
Explorations in Southern Mexico.....	Allan Miner
A Battle in Mid Air.....	Boswick Paine

Specimen of 10-Point Three Dots to the Em Lining Leaders used with Hansen's 10-Point Lining Stratford Old Style

Evening Bells.....	George Irving
The Whispering Waves.....	Adams
Rose of My Heart.....	Mattures
Reverie.....	Otto Kirkmann
An Old Garden.....	Hope Temple

Specimen of 8-Point One Dot to the Em Lining Leaders used with Hansen's Lining Caslon Old Style No. 2

Coming Home from the Fields	25
Hunting the Partridge	37
A Good Shot on the Wing	53
Fishing for Speckled Trout	69
A Camp in the Mountains	81

Specimen of 12-Point Fine Round Dot Lining Leaders used with Hansen's Lining Caslon Old Style No. 2

Wedding March.....	Wagner
In After Years.....	Blake
Blue Danube Waltzes.....	Strauss
After the Ball.....	Harris
Just for Fun.....	Von Tilzer

THE H. C. HANSEN TYPE FOUNDRY



JOB AND BODY TYPE ACCENTS

The accents that we make are divided into different languages as follows

French
à á â ç é è ê ë ì í î ï ò ù ü ú
À Ç É Ê Ë Ì Í Î Ï Ò Ó

Portuguese
á â ç é ê í ñ ò ó ô ú ü
Á Â Ç É Ê Í Ñ Ò Ó Ô Û Ü

Swedish
å ä ö Å Ä Ö A Ä Ö

Danish and Norwegian
ø ö Ø Ö

Bohemian
á ě é í ó ř s ú ŷ z Á Ě É Í Ó Ř
Š Ů Ÿ Ž

German
ä ö ü Ä Ö Ü

Italian
à è ì ù Ì È Ì Ò Ù

Hungarian
á é í ó ö ü Á É Í Ó Ö Ü

Polish
ą ę ł ń ó ś ź z Ą Ć Ę Ł Ń Ó Ś Ź Ż

Spanish
á é í ó ú ü ñ Á É Í Ó Ú Ñ
À É Í Ó Ú Ñ

Below is a complete list of accents made in the different sizes of body and job type as specified and shown in this specimen book:

BODY TYPE ACCENTS

OLD STYLE No. 110

6-Point—à á â ç é è ê ë ì í î ï ò ó ô ú ü
ù û ŷ z Ä Å Ö

8-Point—à á â ç é è ê ë ì í î ï ò ó ô ú ü
ù û ŷ z Ä Å Ö
È Ê É Í Ó Ô Û Ü Ñ Ç
À Á Ä È É Í Ó Ô Û Ü Ç

10-Point—à á â ç é è ê ë ì í î ï ò ó ô ú ü
ù û ŷ z Ä Å Ö
È Ê É Í Ó Ô Û Ü Ñ Ç
À Á Ä È É Í Ó Ô Û Ü Ç

11-Point—à á â ç é è ê ë ì í î ï ò ó ô ú ü
ù û ŷ z Ä Å Ö

12-Point—à á â ç é è ê ë ì í î ï ò ó ô ú ü
ù û ŷ z Ä Å É Í Ó Ñ
Û Ñ Á É Í Ó Ñ

OLD STYLE No. 110 ITALIC

8-Point—à á â ç é è ê ë ì í î ï ò
ó ô ú û ŷ z Ä Å É È È

OLD STYLE No. 110 ITALIC. Continued

10-Point—à á â ç é è ê ë ì í î ï ò
ó ô ú û ŷ z Ä Å É È È

11-Point—à

CASLON OLD STYLE No. 2

6-Point—à á â ç é è ê ë ì í î ï ò
ó ô ú û ŷ z Ä Å É È È É Í Ó Ô Û Ü Ñ Ç

8-Point—à á â ç é è ê ë ì í î ï ò
ó ô ú û ŷ z Ä Å É È È É Í Ó Ô Û Ü Ñ Ç

10-Point—à á â ç é è ê ë ì í î ï ò
ó ô ú û ŷ z Ä Å É È È É Í Ó Ô Û Ü Ñ Ç

12-Point—à á â ç é è ê ë ì í î ï ò
ó ô ú û ŷ z Ä Å É È È É Í Ó Ô Û Ü Ñ Ç

18-Point—à á â ç é è ê ë ì í î ï ò
ó ô ú û ŷ z Ä Å É È È É Í Ó Ô Û Ü Ñ Ç

24-Point—à á â ç é è ê ë ì í î ï ò
ó ô ú û ŷ z Ä Å É È È É Í Ó Ô Û Ü Ñ Ç

CASLON O. S. ITALIC No. 2

6-Point—à á â ç é è ê ë ì í î ï ò
ó ô ú û ŷ z Ä Å Ö

8-Point—à á â ç é è ê ë ì í î ï ò
ó ô ú û ŷ z Ä Å Ö

10-Point—à á â ç é è ê ë ì í î ï ò
ó ô ú û ŷ z Ä Å Ö

12-Point—à á â ç é è ê ë ì í î ï ò
ó ô ú û ŷ z Ä Å Ö

OLD STYLE No. 112

6-Point—à á â ç é è ê ë ì í î ï ò
ó ô ú û ŷ z Ä Å Ä É È È É Í Ó Ô Û Ü Ñ Ç
À Á Ä È É Í Ó Ô Û Ü Ç

8-Point—à á â ç é è ê ë ì í î ï ò
ó ô ú û ŷ z Ä Å Ä É È È É Í Ó
Ô Û Ü Ñ Ç À Á Ä È È É Í Ó Ô Û Ü Ç

10-Point—à á â ç é è ê ë ì í î ï ò
ó ô ú û ŷ z Ä Å Ä É È È É Í Ó Ô Û Ü Ñ Ç
À Á Ä È È É Í Ó Ô Û Ü Ç

12-Point—à á â ç é è ê ë ì í î ï ò
ó ô ú û ŷ z Ä Å Ä È È É Í Ó Ô Û Ü Ñ Ç

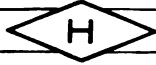

JOB TYPE ACCENTS. Continued

LINING GOTHIC No. 18

6-Point—á à å ä ç é è ê í î ñ
ó ô ó ú ü ú

8-Point—á à å ä ç é è ê í î ñ
ó ô ó ú ü ú

10-Point—á à å ä ç é è ê í î ñ
ó ô ó ú ü ú

12-Point—á à å ä ç é è ê í î ñ
ó ô ó ú ü ú

14-Point—á à å ä ç é è ê í î ñ
ó ô ó ú ü ú

18-Point—á à å ä ç é è ê í î ñ
ó ô ó ú ü ú

24-Point—á à å ä ç é è ê í î ñ
ó ô ó ú ü ú

30-Point—á à å ä ç é è ê í î ñ
ó ô ó ú ü ú

36-Point—á à å ä ç é è ê í î ñ
ó ô ó ú ü ú

42-Point—á à å ä ç é è ê í î ñ
ó ô ó ú ü ú

48-Point—á à å ä ç é è ê í î ñ
ó ô ó ú ü ú

54-Point—á à å ä ç é è ê í î ñ
ó ô ó ú ü ú

BUFFALO ITALIC

12-Point—á à å ä ç é è ê í î ñ
ó ô ó ú ü ú

18-Point—á à å ä ç é è ê í î ñ
ó ô ó ú ü ú

DE VINNE CONDENSED

24-Point—ó ç é í ñ s z z ó ç é ñ
š ž ž

GERMAN

10-Point—á à å ä ç é è ê í î ñ
Ä Ö Ü

BOLDFACE No. 15

6-Point—á à å ä ç é è ê í î ñ
ó ô ó ú ü ú

8-Point—á à å ä ç é è ê í î ñ
ó ô ó ú ü ú

STRATFORD OLD STYLE

6-Point—á à å ä ç é è ê í î ñ
ó ô ó ú ü ú

8-Point—á à å ä ç é è ê í î ñ
ó ô ó ú ü ú

10-Point—á à å ä ç é è ê í î ñ
ó ô ó ú ü ú

12-Point—á à å ä ç é è ê í î ñ
ó ô ó ú ü ú

HUNNEWELL

6-Point—á à å ä ç é è ê í î ñ
ó ô ó ú ü ú Ä Å Ä È
É Ê Í Ö Ö Ü Ñ Ç

8-Point—á à å ä ç é è ê í î ñ
ó ô ó ú ü ú Ä Å Ä È
É Ê Í Ö Ö Ü Ñ Ç

10-Point—á à å ä ç é è ê í î ñ
ó ô ó ú ü ú Ä Å Ä È
É Ê Í Ö Ö Ü Ñ Ç

12-Point—á à å ä ç é è ê í î ñ
ó ô ó ú ü ú Ä Å Ä È
É Ê Í Ö Ö Ü Ñ Ç

LATIN CONDENSED

10-Point—á à å ä ç é è ê í î ñ
ó ô ó ú ü ú

12-Point—á à å ä ç é è ê í î ñ
ó ô ó ú ü ú

18-Point—á à å ä ç é è ê í î ñ
ó ô ó ú ü ú

24-Point—á à å ä ç é è ê í î ñ
ó ô ó ú ü ú

36-Point—á à å ä ç é è ê í î ñ
ó ô ó ú ü ú

48-Point—á à å ä ç é è ê í î ñ
ó ô ó ú ü ú

GOthic CONDENSED No. 4

6-Point—á à å ä ç é è ê í î ñ
ó ô ó ú ü ú

8-Point—á à å ä ç é è ê í î ñ
ó ô ó ú ü ú

10-Point—á à å ä ç é è ê í î ñ
ó ô ó ú ü ú

12-Point—á à å ä ç é è ê í î ñ
ó ô ó ú ü ú

18-Point—á à å ä ç é è ê í î ñ
ó ô ó ú ü ú

20-Point—á à å ä ç é è ê í î ñ
ó ô ó ú ü ú

24-Point—á à å ä ç é è ê í î ñ
ó ô ó ú ü ú

42-Point—á à å ä ç é è ê í î ñ
ó ô ó ú ü ú

BUFFALO

6-Point—á à å ä ç é è ê í î ñ
ó ô ó ú ü ú ñ ç Ä Å Ä È
É Ê Í Ö Ö Ü Ñ Ç

8-Point—á à å ä ç é è ê í î ñ
ó ô ó ú ü ú ñ ç Ä Å Ä
È É Ê Í Ö Ö Ü Ñ Ç

10-Point—á à å ä ç é è ê í î ñ
ó ô ó ú ü ú ñ ç Ä Å Ä
È É Ê Í Ö Ö Ü Ñ Ç

12-Point—á à å ä ç é è ê í î ñ
ó ô ó ú ü ú ñ ç Ä Å Ä
È É Ê Í Ö Ö Ü Ñ Ç

18-Point—á à å ä ç é è ê í î ñ
ó ô ó ú ü ú ñ ç Ä Å Ä
È É Ê Í Ö Ö Ü Ñ Ç

48-Point—á à å ä ç é è ê í î ñ
ó ô ó ú ü ú

GOthic CONDENSED No. 400

*6-Point—á à å ä ç é è ê í î ñ
ó ô ó ú ü ú

8-Point—á à å ä ç é è ê í î ñ
ó ô ó ú ü ú

10-Point—á à å ä ç é è ê í î ñ
ó ô ó ú ü ú

12-Point—á à å ä ç é è ê í î ñ
ó ô ó ú ü ú

18-Point—á à å ä ç é è ê í î ñ
ó ô ó ú ü ú

24-Point—á à å ä ç é è ê í î ñ
ó ô ó ú ü ú

36-Point—á à å ä ç é è ê í î ñ
ó ô ó ú ü ú

48-Point—á à å ä ç é è ê í î ñ
ó ô ó ú ü ú

*Also made in 14, 30 and 54-Point

PIECE ACCENTS

2-Point Piece Accents										Per Font, \$0.50					6-Point Piece Accents										Per Font, \$1.00				
1	2	3	4	5	6	7	8	9	10	11	12	13	14	15	1	2	3	4	5	6	7	8	9	10	11	12	13	14	15
ˆ	˜	˘	˙	˚	˛	˜	˘	˙	˚	ˆ	˜	˘	˙	˚	ˆ	˜	˘	˙	˚	˛	˜	˘	˙	˚	˛	˜	˘	˙	˚

PRICE LIST OF ACCENTS

Body and job type accents are put up in fonts according to languages listed at 35¢ per font in sizes from 6 to 12-Point and at 50¢ per font for sizes larger than 12-Point. Any accent cast to order in quantities of no less than 4 ounces each at a minimum charge of 60¢. In quantities at second class rates per pound unless ordered with weight fonts at same time. Special characters cut to order at special prices.

**THE LINING
CASLON
FULLFACE**

ESTABLISHED 1872

**THE H. C. HANSEN TYPE
FOUNDRY**

**190-192 CONGRESS STREET, BOSTON
43 CENTRE STREET, NEW YORK**

BORDER: BRASS RULF NOS. 623, 316, 106, AND 6-PT. BORDER NO. 9. BERKSHIRE ORN. 62

LINING CASLON FULLFACE

STANDARD LINE

6-Point 22A \$0.95 44a \$1.05 \$2.00

BALANCE OF COMPOSING AND PRESS ROOMS MOST Essential to profitable operation of printing offices. That the composing room is considered the unprofitable department by many printers is due, in many instances, to their failure to keep the growth of the composing room equivalent to that of the press room. That more type and material is required for the operation of several cylinder presses than for the operation of one press is obvious, yet many printers lose sight of this fact. 398

8-Point 19A \$1.10 38a \$1.15 \$2.25

FONTS OF LIBERAL SIZE MOST IMPORTANT Printers believe, and tell their customers, that advertising should be judged by results and not by price paid. The same argument holds good as to equipment. An investment in sufficient material to avoid expensive delays in hunting sorts and hold-ups of the presses is most conducive to a fat pocket book

10-Point 16A \$1.20 32a \$1.30 \$2.50

JOB TYPE IS SOLD AT BODY PRICES Never have printers been able to secure type and supplies at such favorable prices and discounts as at the present time. The printer who is continually out of sorts has only himself to blame. Hansen Type Best

12-Point 16A \$1.30 32a \$1.45 \$2.75

BEST TYPE FOR THE PRINTER The best to use because it is the most accurate and durable. The best to buy, being all made under one roof prompt shipment is assured and orders for sorts can be quickly filled 5

14-Point 12A \$1.40 24a \$1.60 \$3.00

IT'S EASY ENOUGH TO BE Pleasant when life flows by like a song; But the man worth while is the man with a smile when everything goes wrong

18-Point

8A \$1.50 16a \$1.75 \$3.25

TO THE ADMIRERS OF CASLON OLD STYLE This series will appeal strongly. Having all desirable characteristics of the Caslon but with a heavier face

THE H. C. HANSEN TYPE FOUNDRY

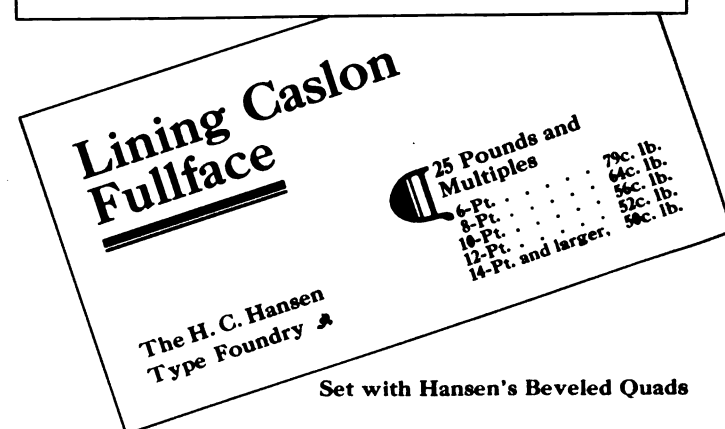
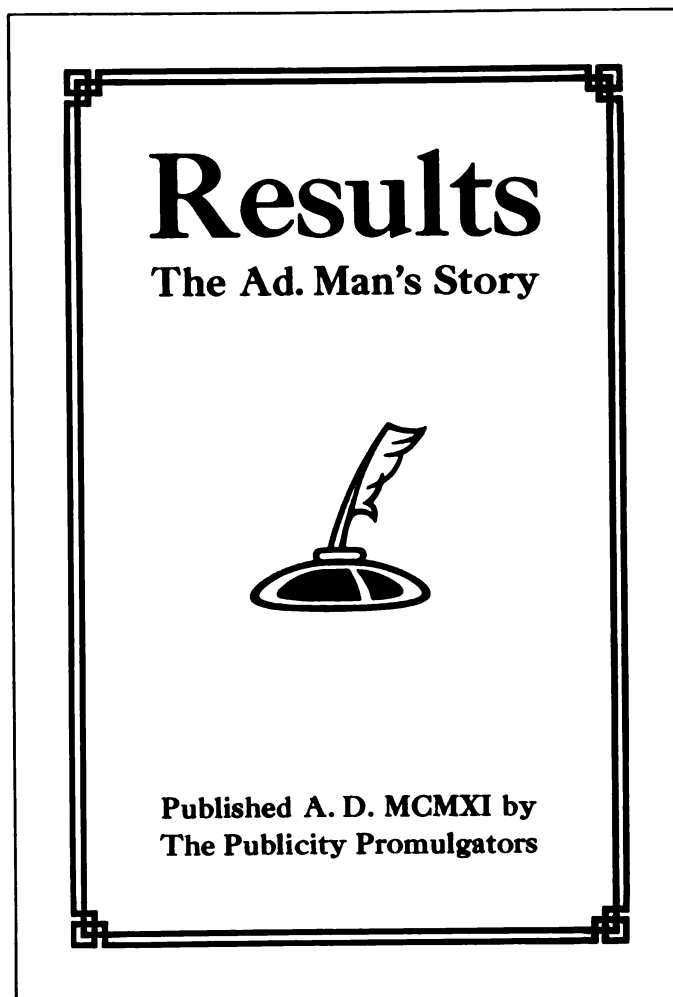

LINING CASLON FULLFACE
STANDARD LINE

36-Point

3A \$2.55 6a \$2.45 \$5.00

OBTAIN BEST QUALITY
Hansen Products Desirable

24-Point

5A \$1.55 12a \$1.95 \$3.50

30-Point

4A \$2.00 9a \$2.25 \$4.25

FINE TYPE FACE **PROFIT SURE**
Progressive Method **Striking Effects**

42-Point

3A \$3.20 6a \$3.05 \$6.25

STRENGTH NOTED
Many Sales Promoted 5

48-Point

3A \$4.25 5a \$3.25 \$7.50

Bindings RICHEST

60-Point

3A \$6.75 4a \$4.00 \$10.75

COINS Elusive

72-Point

3A \$8.50 4a \$5.00 \$13.50

Extra PRIZE

THE H. C. HANSEN TYPE FOUNDRY

The University Literary Society

*In an Elaborate Dramatic Production
of Shakespeare's*

HAMLET

In DENSMORE HALL
TUESDAY EVENING
MARCH FIFTEENTH
NINETEEN HUNDRED TWELVE

Tickets, Thirty-five Cents

**Reserved Seats, Seventy-five Cents, will be on sale at
Clarke's Book Shop after March First**

10-PT. EDUCATORS NO. 4 PRINTERS' JOBS NO. 8 AND 9

CASLON FULLFACE ITALIC

STANDARD LINE

6-Point 20A \$0.80 60a \$1.20 \$2.00

**PRINTING TRADE RECOGNIZED AS COMMERCIAL BAROMETER
CONDITIONS INDICATE THE RISE AND FALL OF PROSPERITY**
Considered as an indicator of the rise or fall of prosperity in the country, the printing and publishing business can almost invariably be relied upon, in that it deals with every calling and is closely identified with the prosperity of each. A manufacturer of shoes has but an academic interest in the piano industry; but both the shoe-maker and the piano man are interested in advertising and printing.

8-Point 19A \$1.00 50a \$1.25 \$2.25

**INTELLIGENT USE OF PRINTING ESSENTIAL TO THE
CONDUCT AND GROWTH OF EVERY INDUSTRY 4358**
There are but few callings, indeed, in which the intelligent or the careless use of printing does not mean the difference between success and failure. The printing and publishing business is thus extremely sensitive to the general prosperity or depression of the entire commercial world. Many gigantic enterprises 75

10-Point 15A \$1.05 45a \$1.45 \$2.50

**PRODUCERS ADVERTISE EXTENSIVELY
IN THE NEWSPAPERS AND MAGAZINES**
If the country prospers, producers advertise in the newspapers and magazines in liberal fashion, and the public subscribe liberally to the various classes of periodicals. Indicating and aiding prosperity

12-Point 14A \$1.15 38a \$1.60 \$2.75

**ORDERS COMMERCIAL PRINTING
QUICK DELIVERY IS REQUIRED 3**
As business booms, the man who has something to promote or sell prints circulars and pamphlets in immense quantities, and with a large degree of elegance and at great expense

18-Point

8A \$1.35 23a \$1.90 \$3.25

FINEST TYPE FACES FOR PRACTICAL PRINTERS
Hansen type is designed with a view to practical utility in the various branches of printing. Not fads, but money earners 26

NOTE—The 14-Pt., 30-Pt., 36-Pt. and 48-Pt. sizes are in preparation

24-Point

6A \$1.75 12a \$1.75 \$3.50

THIS IS A VERY DESIRABLE SERIES
A companion face to our Lining Caslon Fullface that should be found in every printing office \$815

THE H. C. HANSEN TYPE FOUNDRY

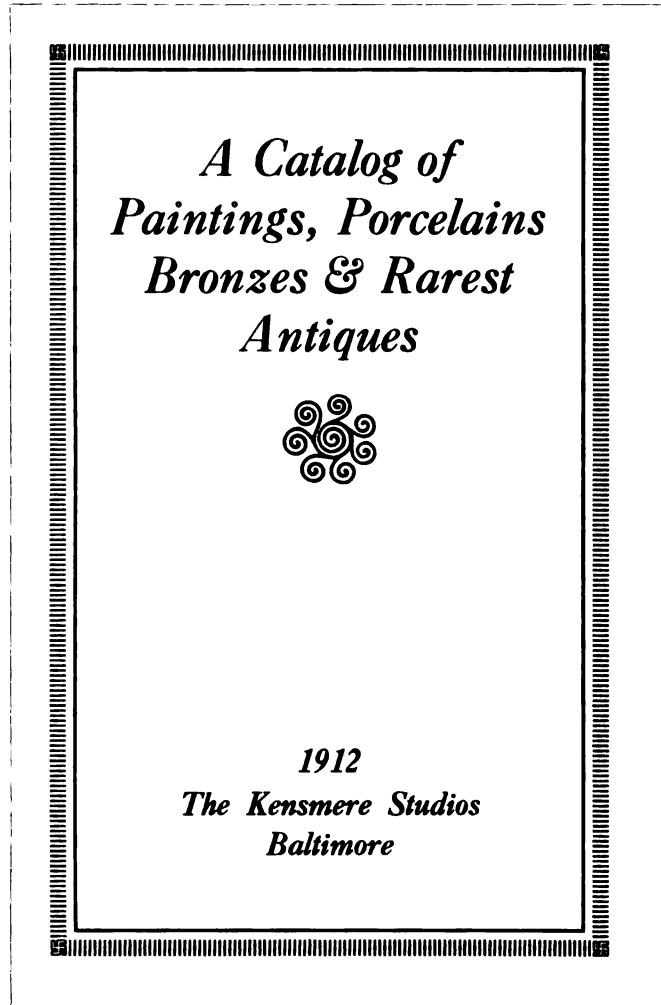

H

Distinctive Printing

Printing that is characterized by neatness and good taste is the kind that attracts attention—the kind that builds a printing business on a foundation that will withstand the fierce storms of competition—the kind that every printer should strive to produce, is facilitated by use of products of New England's only Independent Type Foundry

The H. C. Hansen Type Foundry

Designers and Makers of Sensible Type Styles

12-PT. BORDER NO. 508 SET WITH BEVELED QUADS. JOINTS NOT SOLDERED

**CASLON
FULLFACE
ITALIC**

*SUPERIOR QUALITY
STANDARD LINE*

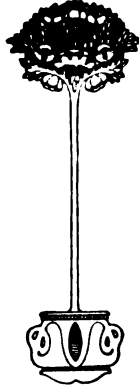

SYMPHONY ORN. 342

**THE H. C. HANSEN
TYPE FOUNDRY**

Established 1872
190-192 CONGRESS ST., BOSTON
43 CENTRE ST., NEW YORK

BOSTON ST. LOUIS SAN FRANCISCO DALLAS ATLANTA

Agricola Manufacturing Company
GUARANTEE

*The AGRICOLA MANUFACTURING COMPANY hereby guarantees
Machine, No. _____, Series _____, to be in perfect working condition and free from all
defects of manufacture, and the above named company agrees to replace, without further charge,
any part thereof that may prove defective, upon receipt of same accompanied by this guarantee,
properly countersigned, within One Year from the date herein set forth.*

(Signed), EARLE D. MARCHANT, President

Date, _____ 19____

Void unless countersigned and dated by agent or dealer Agent or Dealer

8-POINT UNIQUE BORDER. 60 INCHES \$1.50

Lining Caslon Full Face

STANDARD LINE

Complete series of this face from 6 to 48-Point are in preparation.

Specimen sheets sent on request.

24-Point

5A \$1.55 12a \$1.95 \$3.50

**A REPUTATION FOR PROMPT-
ness is one of the things that a job
printer should strive for. He will
have gained a great advantage when
it can be said of him that he always
gets work out on time, and it will
pay him to endeavor to secure 129**

6, 8, 10 and 12-Point sizes shown on page 32

Lining Caslon Full Face Italic

STANDARD LINE

Series of this face from 6 to 24-Point are in preparation.

Specimen sheets sent on request.

24-Point

6A \$1.75 12a \$1.75 \$3.50

*A REPUTATION FOR PROMPT-
ness is one of the things that a job printer
should strive for. He will have gained a
great advantage when it can be said of him
that he always gets work out on time, and
it will pay him to endeavor to secure such
a reputation by every means in his \$4679*

CASLON OLD STYLE No. 2

STANDARD LINE

Caslon Old Style Number Two

is one of the prettiest faces ever cut of this ever popular type. It is cast in fourteen sizes on the standard line from superior copper alloy metal

6-Point

22A \$0.85 60a \$1.15 \$2.00

IN SETTING DISPLAY LINES a compositor can waste the time and energy not only of himself, but also that of his fellow workmen, if he is careless in handling the material, especially in offices where there is not an overabundant supply of the various fonts. It is often necessary to set up a number of "try" lines before a compositor will find the type suitable to his purpose. When he finds that a line of type which he has set is either too small or too large, too heavy or too light, such line should immediately be replaced in the case from which it was taken, and not dumped on a galley or frame. Some other compositor may wish to use the same type, and, not finding it in the case, he will either have to turn sorts, which must later be replaced, or hunt for it on the dead stone or perhaps pull out numberless boards on which dead matter is kept before he finally finds the sorts needed, this is time and exertion which could have been saved if the lines had been replaced in the case after finding it did not answer his purpose. It is the same in regard to

8-Point

20A \$1.00 48a \$1.25 \$2.25

IN SETTING DISPLAY LINES a compositor can waste the time and energy not only of himself, but also that of his fellow workmen, if he is careless in the handling of material, especially in offices where there is not an overabundant supply of the various fonts. It is often necessary to set up a number of "try" lines before a compositor will find the type suitable to his purpose. When he finds that a line of type which he has set is either too small or too large, too heavy or too light, such a line should immediately be replaced in the case from which it was taken, and not dumped on a galley or frame. Some other compositor may

10-Point

18A \$1.15 40a \$1.35 \$2.50

IN SETTING DISPLAY LINES a man can waste the time and energy not only of himself, but also that of his fellow workmen, if he is careless in the handling of material, especially in offices where there is not an overabundant supply of the various fonts. It is often necessary to set up a number of "try" lines before a compositor will find the type suitable to his purpose.

12-Point

15A \$1.30 32a \$1.45 \$2.75

IN SETTING DISPLAY LINES a compositor can waste the time and energy not only of himself, but also that of his fellow workmen, if he is careless in the handling of material, especially in offices where the supply of the fonts is not overabundant

14-Point

14A \$1.50 28a \$1.50 \$3.00

IN SETTING DISPLAY LINES a man can waste the time and energy not only of himself, but also that of his fellow workmen, if he is careless in the handling of material, especially

16-Point

10A \$1.50 20a \$1.50 \$3.00

IN SETTING display lines a compositor can waste the time and energy not only of himself, but also that of his

18-Point

10A \$1.55 20a \$1.70 \$3.25

IN SETTING display lines a man can waste the time and energy not only of himself but

20-Point

8A \$1.60 16a \$1.65 \$3.25

IN SETTING DISPLAY lines a man can waste the time and energy not only

24-Point

6A \$1.75 12a \$1.75 \$3.50

LINING TYPE ALWAYS IN DEMAND
Durable Metal used in Caslon Old Style No. 2

1234567890

MODERN

1234567890

OLD STYLE

Modern and O. S. Figures are both cast for this type. Modern Figures come with font. Small Caps of 6, 8, 10 and 12-Pt. in separate fonts, 50c each

THE H. C. HANSEN TYPE FOUNDRY

CASLON OLD STYLE No. 2

STANDARD LINE

72-Point

3A \$7.75 4a \$4.75 \$12.50

BEST of Faces

64-Point

3A \$5.30 4a \$3.45 \$8.75

STONE Quality

42-Point

3A \$3.25 6a \$2.75 \$6.00

CASLON Old Style is Popular

36-Point

4A \$2.75 6a \$2.00 \$4.75

MATRICE of this type newly made

30-Point

5A \$2.00 10a \$2.25 \$4.25

CASLON TYPES MUCH USED In Fourteen Carefully Graded Sizes

THE H. C. HANSEN TYPE FOUNDRY

LINCOLN
MILITARY
ACADEMY

SALEM, MASSACHUSETTS



A REVISED CATALOGUE OF STUDIES
DRILLS & EXERCISES, WITH WHICH
IS GIVEN A LIST OF THE STUDENTS

CASLON OLD STYLE ITALIC No. 2

Standard Line

42-Point

4A \$3.50 7a \$2.75 \$6.25

OLD STYLE Printing 375

24-Point

6A \$1.70 12a \$1.80 \$3.50

PRINTSHOPS
Demand this letter

20-Point

7A \$1.50 16a \$1.75 \$3.25

FLOWER GIRLS
Elegantly Dressed 68

18-Point

9A \$1.30 25a \$1.95 \$3.25

SUMMER SPORTS
In the Shade of the Pines

16-Point

9A \$1.40 22a \$1.60 \$3.00

SECOND THOUGHTS
Reveal unto us a true insight

14-Point

12A \$1.35 34a \$1.65 \$3.00

MUCH HAS BEEN SPOKEN
Concerning the correct use of Italics

12-Point

14A \$1.20 42a \$1.55 \$2.75

CHANGING OF TYPE DESIGNS
Requires time and labor and very often

10-Point

16A \$1.00 50a \$1.50 \$2.50

MORE THAN TWO HUNDRED YEARS
Have Caslon types been in use and today they are more popular than ever, which goes to prove it

8-Point

18A \$1.00 55a \$1.25 \$2.25

PRINTING MATERIAL SUPPLIED QUICKLY
Promptness in supplying the wants of printers has always been a feature of The Hansen Type Foundry at Boston, Mass.

6-Point

22A \$0.85 68a \$1.15 \$2.00

TYPES OF EXCELLENCE ARE EAGERLY SOUGHT
Buyers of printing seek for striking typographical effects, resulting from the harmonious assembling of Caslon Old Style Italic No. 2

ILLUSTRATED PRICE LIST

Colt's Armory Presses

DESIGNED & PATENTED BY JOHN THOMSON, C. E.
BUILT AT COLT'S ARMORY BY COLT'S PATENT
FIREARM MANUFACTURING COMPANY
HARTFORD, CONNECTICUT, U. S. A.



JOHN THOMSON PRESS CO.

253 Broadway, New York City

36-Point

4A \$2.70 8a \$2.50 \$5.20

RULES & Leads

30-Point

4A \$2.10 9a \$2.15 \$4.25

Attractive PRINT

THE H. C. HANSEN TYPE FOUNDRY

Sterling Coated. See page 377

48



LINING VIKING OLD STYLE ITALIC No. 3

STANDARD LINE

6-Point

28A \$1.00 50a \$1.00 \$2.00

THE SAME DAY AS VIKING LANDED AT THE ISLAND, HE WENT ashore to amuse himself. He turned his steps to a forest and then grew very hot. Having come to an open place in the forest, he sat down, and saw a woman of exquisite beauty walking along. She came up to him, greeted him very courteously, and he received her very kindly. They talked together a long time, and their conversation was very friendly. He asked her name and she said it was Solbjort (sun-bright). She then asked him if he was not thirsty, as he walked so far, but Viking said he was not. She then took a horn, which she had kept under her cloak, offered him a drink from it, and he accepting it, and drinking therefrom, became sleepy, and bending his body into the lap of Solbjort, he fell asleep. But when he woke up again she had entirely disappeared. The drink had made somewhat strange, and his whole body was weather was gusty and cold, and he had for

8-Point

25A \$1.25 40a \$1.00 \$2.25

THE SAME DAY AS VIKING LANDED AT THE ISLAND he went ashore to amuse himself. He turned his steps toward a forest and then grew very hot. Coming to an open place in the forest, he sat down, and saw a woman of exquisite beauty walking along. She came up to him, greeted him very courteously, and he received her very kindly. They talked together a long time, and their conversation was very friendly. She then took a horn, which she had kept under her cloak, offered him a drink from it, and he accepting it, and drinking therefrom, became his body into the lap of Solbjort, he But when he woke up she had entirely

12-Point

15A \$1.25 36a \$1.50 \$2.75

AS VIKING LANDED island he went ashore to himself. Having come place in the forest he saw woman of exquisite beauty. She came up to him, greeted her very kindly. They talked together a long time and conversation was friendly. She then asked him if he thirsty, as he had walked

10-Point

20A \$1.25 36a \$1.25 \$2.50

AS THE VIKING LANDED land, he went ashore to amuse He turned his steps to a forest grew very hot. Having come open place in the forest, he sat and saw a woman of exquisite beauty walking along. She came to him, greeted him very courteously and he received her very kindly. They talked together a long time and conversation was very friendly her name and she said it was She then asked him if he was as he had walked so far, but

16-Point

12A \$1.40 20a \$1.35 \$2.75

A VIKING OF OLD brave and fearless a dragon ships which out of water and was Halfdan was a large strong-looking man he learned of the fact he went on board his they found him very weak. And thus it was agreed that they should

18-Point

10A \$1.50 20a \$1.75 \$3.25

A SON OF ULF One day he saw ships passing the at the meeting of they asked each said his name was and was a son of Ulf. Halfdan was a large and strong-looking man, and when

VIRGINIA DARE WINE

Light, moderately sweet, the pure and wholesome essence of the *Scuppernon*, the Queen Grape of America.

Rich in the health-giving qualities that make wine the great nerve nourisher — an indispensable element of your daily food.

The flavor and bouquet of "Virginia Dare" are unrivalled by Hungary's rarest Tokays, making it not only the accepted wine for daily use, but ideal for all occasions and ceremonies sacred to the home.

Mention your dealer's name and write for our interesting book, *sent free* —

"The Art of Serving Wine"

Tells when, where and how to correctly serve wines; describes Garrett's "Virginia Dare" and other pure, wholesome wines.
We insist upon refunding your money if you are not satisfied, whether you buy from us or your dealer. Write to-day.

GARRETT & COMPANY
502 Berkley Avenue, Norfolk, Va.

24-Point

6A \$1.70 13a \$1.80 \$3.50

THE NEW AND ORIGINAL VIKING ITALIC Exclusive design by The Hansen Type Foundry

THE H. C. HANSEN TYPE FOUNDRY

LINING VIKING OLD STYLE No. 3

Patented

Standard Line

8-Point

25A \$1.25 35a \$1.00 \$2.25

THE MARINER SAILING IN THE BALTIC, as he skirts the shores of Gotland, sees on a promontory of the island several large cairns and mounds overlooking the sea, and the country that surrounds them. This promontory was the burial-place of a family of great Vikings and rulers who held sway over the whole island a few centuries before and after our era. Among the most conspicuous cairns two are pointed out to the stranger, those of Hjorvard and his son Ivar, the hero of the present narrative. The events of which I am going to speak to you relate to them, and to what happened during their lives, toward the latter end of the third and the beginning of the fourth century, between the years A. D. 270 and 320, or about sixteen hundred years ago. Hjorvard, "the wide spreading," so called on account of the widely extended maritime expeditions he

12-Point

18A \$1.30 30a \$1.20 \$2.50

THE MARINER SAILING IN THE BALTIC, as he skirts the shores of Gotland, sees on a promontory of the island several large cairns and mounds overlooking the sea, and the country that surrounds them. This promontory was the burial-place of a family of great Vikings and rulers who held sway over the whole island a few centuries before and after our era. Among the most conspicuous cairns two are pointed out to ch I am going to speak to you relate to them ned during their lives, toward the latter end

VIKING TALES

THE same day as Viking landed at the island, he went ashore to amuse himself. He turned his steps to a forest and then grew very hot. Having come to an open place in the forest, he sat down, and saw a woman of exquisite beauty walking along. She came up to him, greeted him very courteously, and he received her very kindly. They talked together a long time, and their conversation was very friendly. He asked her name and she said it was Solbjort (sun-bright). She then asked him if he was not thirsty, as he had walked so far, but Viking said he was not. She then took a horn, which she had kept under her cloak, offered him a drink from it, and he accepting it, and drinking therefrom, became sleepy, and bending his body into the lap of Solbjort, he fell asleep. But when he woke up again she had entirely disappeared. The drink had made him feel somewhat strange, and his whole body was shivering; the weather was gusty and cold, and he had forgotten nearly everything of the past, and least of all did he recollect Hunver. He then went to his ship and departed from that place. One day sailing to land, they saw three ships passing the harbor, and at the meeting they asked for each others' names. Viking told his name, but the other chieftain said his name was Halfdan, and that he was a son of Ulf. Halfdan was a large and strong-looking man, and when he learned of the condition of Viking he went on board his ship, where they found him very weak. And thus it was agreed that they should become foster-brothers. Halfdan had a great dragon, called Ironram; all of his ship that stood out of water was iron bound; it rose high out of the sea and was a very costly treasure. Having spent a short time there they left the place and went home to Svafe. The mariner sailing in the Baltic, as he skirts the shores of Gotland, sees on a promontory of the island several large cairns and mounds overlooking the sea and the country that surrounds them. This promontory was the burial-place of a family of great Vikings and rulers who held sway over the whole island a few centuries before and after our era. Among the most conspicuous cairns two are pointed out to the stranger, those of Hjorvard and his son Ivar, the hero of the present narrative. The events of which I am going

6-Point

25A \$1.00 50a \$1.00 \$2.00

18-Point

12A \$1.75 20a \$1.50 \$3.25

GREAT VIKINGS RULED the island of Gotland years ago and their burial-place can still be seen on a promontory of the island which overlooks the 27

36-Point

5A \$2.75 8a \$2.25 \$5.00

VIKING TYPE Popular Designs Figures Plain 65

42-Point

4A \$3.30 6a \$2.50 \$5.80

BATTLES 49 Won and Lost

THE H. C. HANSEN TYPE FOUNDRY

LINING VIKING OLD STYLE No. 3

Patented

Standard Line

10-Point

21A \$1.20 22a \$1.30 \$2.50

THE MARINER SAILING IN THE BALTIC, as he skirts the shores of Gotland, sees on a promontory of the island several large cairns and mounds overlooking the sea, and the country that surrounds them. This promontory was the burial-place of a family of great Vikings and rulers who held sway over the whole island a few centuries before and after our era. Among the most conspicuous cairns two are pointed out to the stranger, those of Hjorvard and his son Ivar, the hero of the present narrative. The events of which I am going to speak to you relate to them, and to what happened during their lives, toward the latter end of the third and the beginning of the fourth century

16-Point

15A \$1.65 25a \$1.35 \$3.00

THE MARINER SAILING IN THE BALTIC, as he skirts the shores of Gotland, sees on a promontory of the island several large cairns and mounds overlooking the sea, and the country that surrounds them. This promontory was the burial-place of a family of great Vikings and rulers who held conspicuous cairns two are pointed

24-Point

8A \$1.95 14a \$1.80 \$3.75

THE ROMAN FLEET never dared to attack the Vikings as they sailed on their various expeditions

30-Point

6A \$2.50 10a \$2.00 \$4.50

BRAVE VIKINGS Sailed and Rowed their Dragon Ships

48-Point

4A \$4.00 7a \$3.50 \$7.50

ISLANDS 8
in the Ocean

VIKINGS

A STORY OF THE
NORTH COUNTRY
TRANSLATED FROM
THE ICELANDIC BY
RASMUS ANDERSON



NEW YORK AND LONDON
FISKE & ANDERSON CO.

THE H. C. HANSEN TYPE FOUNDRY

51

U. OF ILL. LIB.



LINING FRENCH OLD STYLE No. 3

48-Point

STANDARD LINE

4A \$4.06 7a \$3.65 \$7.70

MASTER of French 7

ABOUT
BIRDS

A LITTLE BOOKLET
WHICH GIVES A DESCRIPTION
OF EVERY KNOWN SPECIES
IN EXISTENCE

BY
JAMES MONTGOMERY

Author of "The Baltimore Oriole,"
"Birds of a Feather," etc.

ILLUSTRATED

BOSTON
THOMAS FISKE & SONS
1905

TWELFTH SEMI-ANNUAL
BANQUET

UNDER AUSPICES OF THE
OWL CLUB



WAYSIDE INN, SUDBURY
FRIDAY EVENING, MAY FIRST

24-Point

7A \$1.85 12a \$1.75 \$3.60

HAPPY DAYS OF AUTUMN RETURN
And with them come news of Old Boreas

36-Point

4A \$2.50 8a \$2.50 \$5.00

MODESTY is very pleasing

When ordering to match type in case, send Cap "H" and lower case "m."

THE H. C. HANSEN TYPE FOUNDRY



12-POINT LINING SMITH PREMIER TYPEWRITER NO. 3

Circular font, 20A \$1.85 100a \$5.40 \$7.25 STANDARD LINE
 Extra justifiers at 50c per pound Job font, 10A \$1.00 50a \$2.75 \$3.75

We take great pleasure in calling the attention of the printing craft to this TYPEWRITER No. 2. It matches exactly the writing executed on the Smith-Premier Machine. It is especially desirable for use in printing through silk or other mediums for the production of imitation type-written letters, etc. Inks to match accurately any ribbon can be supplied. In printing through silk the best results are

ABCDEFGHIJKLMNOPQRSTUVWXYZ abcdefghijklmnopqrstuvwxyz
 1234567890 /&%\$#@() .,;:-'!"?!

12-POINT STENOGRAP

Circular font, 20A \$1.80 60a \$2.70 \$4.50 Extra justifiers at 50c per pound Job font, 10A \$1.00 35a \$1.75 \$2.75

We wish to call the attention of every printer to the HANSEN COMPLETE MITERER, a time and money saver in mitering rules. The rule holder has an angle of 90 degrees, so when placed in a central position you can miter square sets a life time without changing its position. It is easily set by a pin for any desired angle having no lines to guess at, thereby

ABCDEFGHIJKLMNOPQRSTUVWXYZ abcdefghijklmnopqrstuvwxyz
 1234567890 æœ/&£%#_*() .,;:-'?!

12-POINT TYPEWRITER No. 1

Circular font, 20A \$2.00 100a \$5.00 \$7.00 Extra justifiers at 50c per pound Job font, 10A \$1.00 50a \$2.75 \$3.75

In regard to the Hansen Complete Mitering Machine purchased some time ago from you would say same is very satisfactory and it has been a source of great saving, having paid for itself many times over, and, in our estimation, stands alone in its line as a time saver and producer of accurate work.

We trust you will keep us posted from time to time on any

ABCDEFGHIJKLMNOPQRSTUVWXYZ abcdefghijklmnopqrstuvwxyz
 1234567890 ()&£_thead#% .,;:-'?!

THE H. C. HANSEN TYPE FOUNDRY

TWO NEW TYPEWRITER FACES

NEW MODEL UNDERWOOD

and

OLIVER PRINTYPE.

*
* *
*

THE H. C. HANSEN TYPE FOUNDRY

Established 1872

190-192 Congress St., Boston

535 Pearl St., New York

TYPEWRITER NO. 2

6-Point

20A \$1.15 80a \$2.35 \$3.50

PERMIT US TO CALL YOUR ATTENTION TO THE TYPE FACES HERE SHOWN For the fac simile reproduction of typewriter work. For advertising circulars and follow-up letters their value is recognized by all the great mail order houses and collection agencies, as their use gives the impression of individual attention to the recipient. For reduced reproduction of testimonial letters the smaller sizes will prove their worth.

ABCDEFGHIJKLMNOPQRSTUVWXYZ& abcdefghijklmnopqrstuvwxyz
\$1234567890 ()'"/%#

8-Point

18A \$1.15 65a \$2.35 \$3.50

NEARLY EVERY PRINTER IS CALLED UPON AT TIMES TO PRINT Fac simile typewriter work. This line of printing is one of the most profitable, and every printer should be equipped with the typewriter type faces made by The H. C. Hansen Type Foundry. The cost is small and the character of the face and the superior metal from which they are cast makes them very durable and desirable.

ABCDEFGHIJKLMNOPQRSTUVWXYZ& abcdefghijklmnopqrstuvwxyz
\$1234567890 ()'"/%#

10-Point

15A \$1.20 55a \$2.30 \$3.50

TO PRINTERS, PUBLISHERS, ADVERTISERS AND ALL Interested in products of the press, our many meritorious type faces, ornaments and our large, attractive assortment of brass rules will prove of great value and are adaptable to requirements of every class of printing.

ABCDEFGHIJKLMNOPQRSTUVWXYZ& \$1234567890
()'"/%# abcdefghijklmnopqrstuvwxyz

THE H. C. HANSEN TYPE FOUNDRY
Boston New York



BARRISTER ITALIC

This italic is the recognized face for legal and law notices. The four sizes are regularly cast on 6, 8, 10 and 12-point bodies. Cast on Standard Line to order in fonts of 25 pounds and multiples on 8, 10, 12 and 14-point bodies.

10-Point

20A \$1.60 60a \$2.00 \$3.60

KNOW ALL MEN BY THESE PRESENTS, that I, Fred E. Dubois, of Derby, County of Norfolk, State of Utah, of the first part, for and in consideration of the sum of one hundred dollars, in lawful money of the United States, to me in hand paid, at, or before the delivery of these presents, by Charles A. Wilcox, of the second part, the receipt of which is hereby acknowledged, have bargained, sold, granted and conveyed, and by these presents do bargain, sell, grant and convey unto the said party of the second part, his executors, administrators and assigns, one pump, three hundred milk bottles, and one covered wagon, to have and to hold the same unto the said party of the second part, his executors, administrators and assigns, forever. And I do for myself, my heirs, administrators and executors, covenant and agree to and with the said party of the second part

6-Point

20A \$1.00 40a \$1.00 \$2.00

KNOW ALL MEN BY THESE PRESENTS, that I, Fred E. Dubois, of the town of Derby, County of Norfolk, State of Utah, of the first part, for and in consideration of the sum of one hundred dollars, in lawful money of the United States, to me in hand paid, at, or before the delivery of these presents, by Charles A. Wilcox, of the second part, the receipt of which is hereby acknowledged, have bargained, sold, granted and conveyed, and by these presents do bargain, sell, grant and convey unto the said party of the second part, his executors, administrators and assigns, one pump, three hundred milk bottles, and one covered milk wagon, to have and to hold the same unto the said party of the second part, his executors, administrators, and assigns, forever. And I do for myself, my heirs, administrators and executors, covenant and agree to and with the said party of the second part, to warrant and defend the said described goods hereby sold unto the said party of the second part, his executors administrators and assigns, against all and every person and persons whatsoever.

In witness whereof, I have hereunto set my hand and seal this twenty third day of July, 1923

Seal []

CHARLES E. DUBOIS.

8-Point

20A \$1.25 40a \$1.25 \$2.50

KNOW ALL MEN BY THESE PRESENTS, that I, Fred E. Dubois, of the town of Derby, County of Norfolk, State of Utah, of the first part, for and in consideration of the sum of one hundred dollars, in lawful money of the United States, to me in hand paid, at, or before the delivery of these presents, by Charles A. Wilcox, of the second part, the receipt of which is hereby acknowledged, have bargained, sold, granted and conveyed, and by these presents do bargain, sell, grant, and convey unto the said party of the second part, his executors, administrators and assigns, one pump, three hundred milk bottles, and one covered milk wagon, to have and to hold the same unto the said party of the second part, his executors, administrators and assigns, forever. And I do for myself, my heirs, administrators and executors, covenant and agree to and with the

12-Point

12A \$1.25 40a \$2.00 \$3.25

KNOW ALL MEN BY THESE PRESENTS, that I, Fred E. Dubois, of the town of Derby, County of Norfolk, State of Utah, of the first part, for and in consideration of the sum of one hundred dollars, in lawful money of the United States, to me in hand paid, at, or before the delivery of these presents, by Charles A. Wilcox, of the second part, the receipt of which is hereby acknowledged, have bargained, sold, granted and conveyed, and by these presents do bargain, sell, grant, and convey unto the said party of the second part, his executors, administrators and assigns, one pump, three hundred milk bottles, and one covered milk wagon, to have and to hold the same unto the said party of the second part, his executors, administrators and assigns forever. And I do for myself, my heirs, administrators and executors, covenant and agree to and with the said party of the second part, to warrant and defend the

THE H. C. HANSEN TYPE FOUNDRY

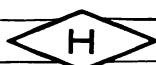

THE HUNNEWELL SERIES

STANDARD LINE

48-Point

4A \$4.75 5a \$3.00 \$7.75

ART EXHIBITION Of Decorative Printing Monday, November 13

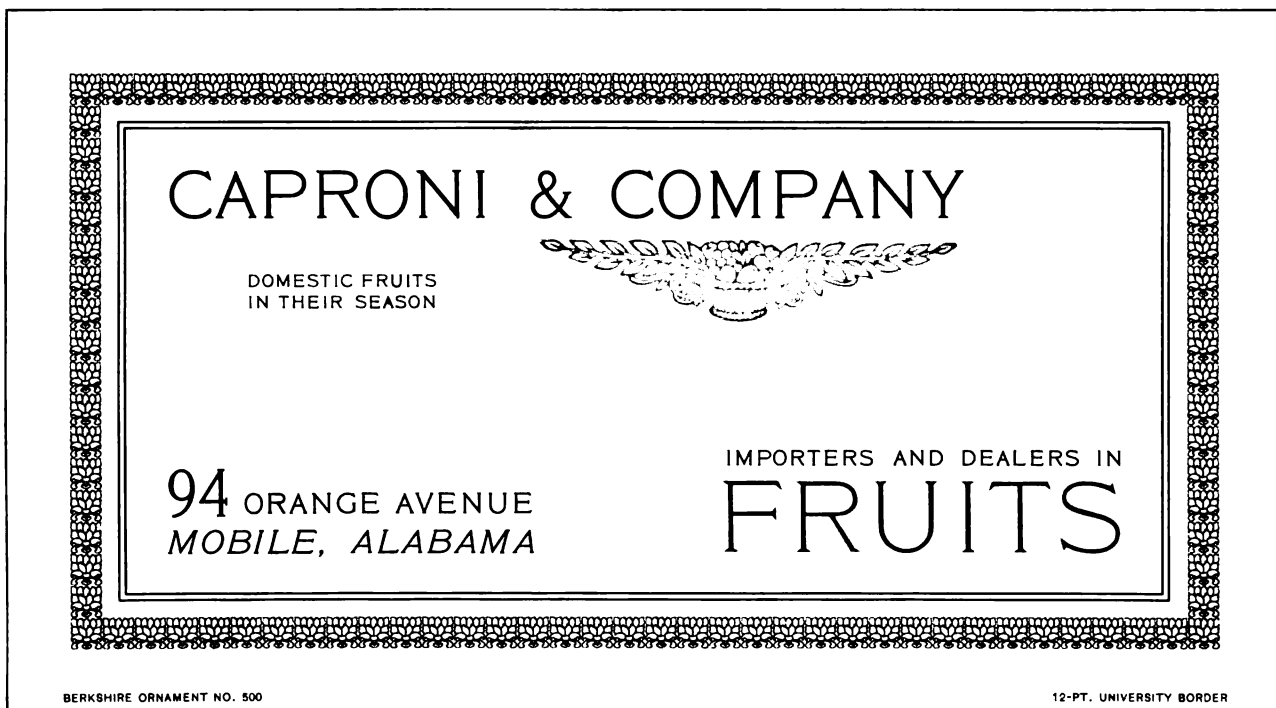

36-Point

4A \$3.00 7a \$2.10 \$5.10

POPULAR TYPE FACES Clever Results Obtained by the Progressive Type Manipulators

THE H. C. HANSEN TYPE FOUNDRY



THE HUNNEWELL SERIES
STANDARD LINE

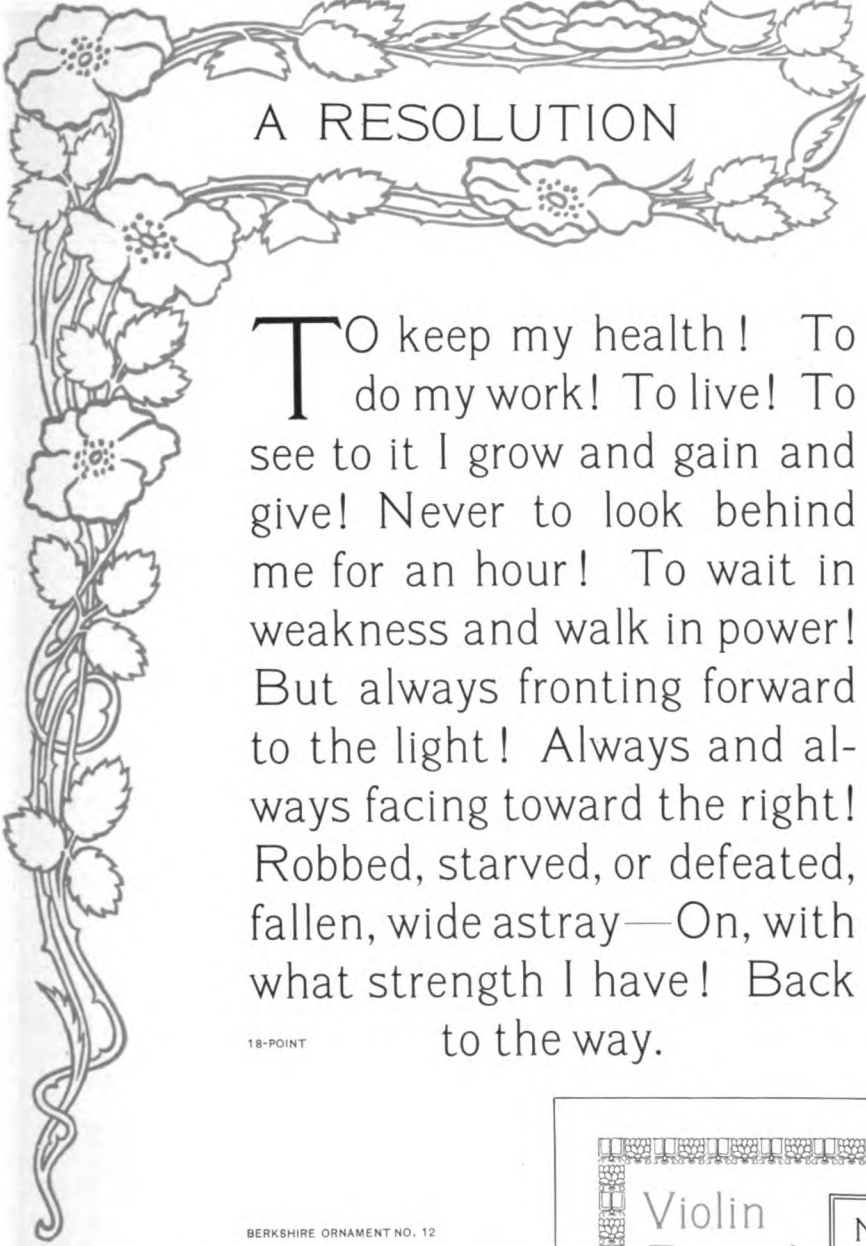

A RESOLUTION

TO keep my health! To do my work! To live! To see to it I grow and gain and give! Never to look behind me for an hour! To wait in weakness and walk in power! But always fronting forward to the light! Always and always facing toward the right! Robbed, starved, or defeated, fallen, wide astray—On, with what strength I have! Back to the way.

18-POINT

BERKSHIRE ORNAMENT NO. 12

Trees

And their Foliage



Published by
The Forest Club
Chicago

BERKSHIRE ORNAMENT NO. 103

HUNNEWELL

SOLD IN BODY FONTS

All sizes of the Hunnewell Type will be sold at body type rates in fonts of twenty-five pounds and its multiples

Violin Recital

NEW ENGLAND CONSERVATORY

Wednesday, April the fifteenth at 8 o'clock. Jordan Hall, Essex Street

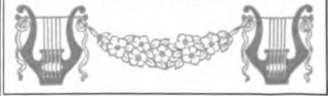

Admit Bearer

BERKSHIRE ORNAMENT NO. 87

10-POINT UNIVERSITY BORDER

THE H. C. HANSEN TYPE FOUNDRY

THE HUNNEWELL SERIES

STANDARD LINE

24-Point

6A \$1.90 12a \$1.70 \$3.50

PRACTICAL PRINTERS EMPHASIZE
The importance of the accurate and unvarying
size of the body of metal types. The continued

18-Point

10A \$1.75 18a \$1.50 \$3.25

USE OF A FEW LETTERS
Varying from the others in size of
body, in a direction of right angles
to the line, even to the smallest
degree, will in the course of a few

12-Point

16A \$1.30 36a \$1.45 \$2.75

LINES CAUSE SUCH CONFUSION AND
JUMBLE OF THE TYPES AS TO MAKE
All further composition impossible. This nicety and
accuracy of size could not be secured by means of
wooden types, nor of metal types the body of which
was fashioned by cutting. It was only to be secured
by casting them in a mould. This, in addition to the

10-Point

20A \$1.25 40a \$1.25 \$2.50

MOVABILITY OF THE LETTERS, WAS WHAT
GUTENBERG INVENTED. THOSE "FORMS"
Which he was so anxious might be discovered in place,
put together, at the time of the trial in 1439, were, most
probably, the three pieces of his adjustable type-mould and
the matrix with it. Of Gutenberg's life or work after the
Fust lawsuit we know very little. Despoiled of his plant

8-Point

22A \$1.15 40a \$1.10 \$2.25

AND AGAIN THROWN UPON HIS OWN RESOURCES, AND
WITHOUT MONEY OR STOCK OR TOOLS, BUT NOT WITH-
Out friends, he continued the work to which he had consecrated his life.
It is some consolation to know that the last years of Gutenberg were passed
in comfort. It appears that in 1465 he was received by Adolf 99, Arch-
bishop of Mainz, as a servant and courtier for life in his residence. The
reason for his appointment is not specified, but it may be regarded as an

6-Point

24A \$1.00 45a \$1.00 \$2.00

APPRECIATION OF THE BENEFITS WHICH THE NEW ART HAD CON-
FERRED UPON THE CHURCH AND THE WORLD AT LARGE. AT THIS
Time Gutenberg, probably enfeebled by the many years of unremunerative and unap-
preciative toil, by the burdens of debt and the trials of disappointment, was not long to
enjoy the ease and comfort of a life at court. On February 26, 1468, Doctor Hummery,
Syndic of Mainz, acknowledges the receipt from the Archbishop of all the "formen, char-
acters and other instruments connected with printing which John Gutenberg left to

HUNNEWELL ITALIC

18-Point

6A \$1.25 22a \$2.00 \$3.25

FORM OF PAGES
Determining the form
of a page of an oblong
shape, irrespective of
its size, a certain pro-

12-Point

12A \$1.10 40a \$1.65 \$2.75

PORTION OUGHT TO BE
MAINTAINED. HAVING A
Page measure diagonally from
corner to corner just twice the
width of the page is in conform-
ity to the law of proportion, es-
tablishing the line of beauty, and

10-Point

15A \$0.95 48a \$1.55 \$2.50

APPLIES EQUALLY TO ALL
SIMILAR SHAPED OBJECTS.
A long brick shaped page however
nicely it is printed does not look well.
When we come to a square page the
true proportion of the diagonal to the
width will be as 10 1-2:6 1-4 the size

8-Point

16A \$0.85 56a \$1.40 \$2.25

OF A GOOD-SIZED QUARTO, INSTEAD
OF 2:1, AS IN THE OBLONG FORM.
And this shape also proves as satisfactory
to the eye as the former one. However large or
small the book may be these proportions should
always be maintained. Before the make-up is
begun a gage should be cut to mark the length

6-Point

16A \$0.70 60a \$1.30 \$2.00

OF THE PAGE. THEN THE MATTER SHOULD
BE ROUGHLY MEASURED OFF TO SEE HOW
The divisions come. There are certain laws in regard to
this that should never be violated. The last line of a para-
graph should never be turned on to the top of a page, nor
must one line of a paragraph be allowed to stand at the foot

THE H. C. HANSEN TYPE FOUNDRY

THE HUNNEWELL SERIES

STANDARD LINE

vi HENRY WADSWORTH LONGFELLOW

IN THOSE days he was described as slight and erect in his figure, with a light, delicate complexion like a maiden's, a slight bloom upon his cheeks, "his nose rather prominent, his eyes clear and blue, and his well-formed head covered with a profusion of brown hair waving loosely." The class to which he belonged had several memorable names, not the least memorable of which was that of Hawthorne. Longfellow held high rank. He was regular and studious in his habits, though he cared more about general reading than the regular curriculum. It is interesting to find him at that early day taking the side of the Indians against the prejudices that have always followed "that reviled and persecuted race." He was greatly delighted with Gray's poems, and regarded Dr. Johnson's criticisms upon them as very unjust. In the winter of 1823 he had some thought of teaching a school, but was on the whole glad that he had failed to obtain one. His chief exercise was walking. When the snow was deep he cut wood, and he found it rather irksome. As a makeshift for either, he wrote his father: "I have marked out an image upon the closet door about my own size; and whenever I feel the need of exercise I strip off my coat and, considering this image as in a posture of defence, make my motions as though in actual combat. This is a very classick amusement.

6-POINT

HENRY WADSWORTH LONGFELLOW viii

SO FAR not a ray of originality, nor one of those graceful, if not always accurate, comparisons or metaphors which peculiarly mark Longfellow's fancy. The Yankee "woodman" is not a singing being, nor have we "larks" under New England skies. It is interesting to know that the *Gazette* then paid its contributors a dollar a column for prose, and got its poetry for nothing. The editor regarded Longfellow's, however, as so full of promise — and any flower in the desert has a smiling aspect — that he had proposed that the poet should receive some compensation

for his regular contributions. This, small as it was, seems to have been enough to excite his ambition toward a literary career. He brought up various objections against the profession of a physician — there were quite enough in the world without him! In another letter to his father he said, "I hardly think Nature designed me for

8-POINT



LONGFELLOW

HIS COMPLETE WORKS

THE ILLUSTRATED DE LUXE EDITION

Boston and Philadelphia
THE MUSEOLA PUBLISHING CO.
MCMVII

BERKSHIRE ORNAMENT NO. 65, 50C.

xv HENRY WADSWORTH

THE following few months in Spain were among the happiest and most romantic of his life, and he never cared to go to Spain again lest the illusion should be destroyed. Longfellow spent a month at Dresden; but social advantages and amusements prevented more serious studies, and as his friend Preble was at Gottingen, he determined to follow and study as much of a year as possible. In the Spring of 1829 he went to England and spent a few days in London, returning through Holland. The Rhine he thought a noble river, but "not so fine as Hudson." The old castle of Vautsberg, near Bingen,

10-POINT

WORTH LONGFELLOW vii

When in Copenhagen he took lessons in the Danish, and he was made a life member of the Royal Society of Northern Antiquities. During a month's enforced stay in Amsterdam he studied Dutch, which he found "in sound the most disagreeable" he remembered having heard except the Russian. His wife was in failing health: she died on the twenty-ninth of November, 1835. Longfellow travelled sadly to Heidelberg, where he found charming companionship, and, as he says of the hero of "Hyperion," "buried himself in old

12-POINT

THE H. C. HANSEN TYPE FOUNDRY



THE HUNNEWELL SERIES

STANDARD LINE

The Particular
Printer

Makes no mistake in ordering a complete series of the Hunnewell type. It prints exceptionally sharp and clear and makes an excellent letter for all classes of commercial printing. There is a refinement and dignity obtained by its use, and will prove itself a paying investment in that it requires but a simple treatment to give pleasing results



BERKSHIRE ORNAMENT NO. 307, 35C.

12-PT SWASTIKA ORNAMENTS, 54 INCHES \$1.50

NEW EDITION of
BOOKS



L. WALLACE
AUTOBIOGRAPHY

THE famous author of "Ben Hur" the book that millions have read, devoted his last few years to the preparation of this remarkable life-story. A man who has won distinction on the diverse fields of arms, letters, politics, and diplomacy must have that in him which compels attention; but this is more than the mere record of a very remarkable career: it is the presentation of the man himself, an intensely individualistic and many sided character, and one of the most picturesque and forceful personalities of our times. His Autobiography must be considered an important human document. It is rich in detail of personal reminiscence, and, although deep where it touches large subjects it is never tedious nor formally historical. Makes a fine present



Two Volumes Crown
8vo. Gift Toss \$5.00



HARPER & SON
NEW YORK

8-PT. BORDER NO. 502, 60 INCHES \$1.50

High Grade **Job Printing**
"THE BETTER KIND"



White, The Printer

Knight Building, Essex Street

ALADDIN ORNAMENTS NO. 12, 15C.

REMEMBER OUR
ANNUAL OFFER

All persons ordering from us direct, during November and December, work amounting to \$10 or more will be given absolutely free, a year's subscription to any of the dollar magazines or papers published

THE H. C. HANSEN TYPE FOUNDRY



THE HUNNEWELL SERIES

STANDARD LINE

WE PRODUCE PROFITABLE ADVERTISING FOR THE LIVE MERCHANT AND MANUFACTURER

WE ARE PREPARED TO
PLAN AND CONDUCT
SYSTEMATIC ADVERTISING
CAMPAIGNS :: :: ::

THE DOAN-WALKER CO.
ADVERTISING SPECIALISTS



PLANNING, WRITING, ILLUSTRATING, ENGRAVING AND PRINTING OF
HIGH-GRADE ADVERTISEMENTS, CATALOGS, BROCHURES, BLOTTERS
JOURNAL BUILDING, NORTH STREET, PITTSBURGH

TELEPHONE, BEACON 437

Dated [] 190

BERKSHIRE ORNAMENT NO. 86. 25C

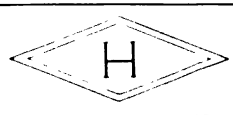

GASPAR BECERRA

By his evening fire the artist
Pondered o'er his secret shame;
Baffled, weary, and disheartened,
Still he mused, and dreamed of fame.

'T was an image of the Virgin
That had tasked his utmost skill;
But alas! his fair ideal
Vanished and escaped him still.

From a distant Eastern island
Had the precious wood been brought;
Day and night the anxious master
At his toil untiring wrought;

Till discouraged and desponding,
Sat he now in shadows deep,
And the day's humiliation
Found oblivion in sleep.

Then a voice cried, "Rise, O master!
From the burning brand of oak
Shape the thought that stirs within thee!"
And the startled artist woke,—

Woke, and from the smoking embers
Seized and quenched the glowing wood;
And therefrom he carved an image,
And he saw that it was good.

O thou sculptor, painter, poet!
Take this lesson to thy heart:
That is best which lieth nearest:
Shape from that thy work of art.

—Longfellow

SYMPHONY ORNAMENT NO. 28. 60C

SPECIAL HUNNEWELL
CHARACTERS

Mr. Dr. Cr. Co. Messrs.

Put up in separate fonts from 6 to 18 point

6-Point, 35 cents 8-Point, 35 cents 10-Point, 35 cents
12-Point, 50 cents 18-Point, 50 cents

THE EVENING STAR

H. W. LONGFELLOW

*Just above yon sandy bar,
As the day grows fainter and dimmer,
Lonely and lovely, a single star
Lights the air with a dusky glimmer.*

*Into the ocean faint and far
Falls the trail of its golden splendor,
And the gleam of that single star
Is ever refulgent, soft, and tender.*

*Chrysaor rising out of the sea,
Showed thus glorious and emulous,
Leaving the arms of Callirrhoe
Forever tender, soft and tremulous.*

*Thus o'er the ocean faint and far
Trail gleams of his falchion brightly;
Is it a God, or is it a star
That entranced I gaze on nightly.*

THE H. C. HANSEN TYPE FOUNDRY

THE PURITAN SERIES

Standard Line

12-Point

18A \$1.40 36a \$1.35 \$2.75

PRINTERS WILL FIND THE PURITAN A TYPE HAVING A WIDE RANGE Of usefulness in the better class of work. For de luxe catalogs and dainty summer resort booklets it is unsurpassed, and it is an ideal letter for announcements, circulars, cards, stationery, dance orders, etc. Bright type faces from Hansen's worked into bright designs by bright printers for intelligent customers

8-Point

25A \$1.05 52a \$1.20 \$2.25

THOSE THINGS ARE CHEAPEST WHICH BRING The largest returns for money invested. The Puritan Series is one that will be profitable for the printer because of its range of usefulness which will enable him to please a large number of customers with a great variety of work. The Puritan type has a pleasing tone and that graceful freedom of design hitherto found only in hand lettered work. Like all Hansen Superior Quality Productions it will prove a money earner for printers

10-Point

21A \$1.25 42a \$1.25 \$2.50

DOES YOUR COMPOSING ROOM SHOW A profit? In many offices the time lost by compositors hunting for sorts in a single year would more than pay for the necessary material to produce work economically and enable them to avoid the delays which are so irritating when encountered on rush jobs. Puritan in large fonts will pay

Special Characters: ch sh fh ct st ft in all fonts

18-Point

10A \$1.75 20a \$1.50 \$3.25

HEIGHTS BY GREAT MEN GAINED AND KEPT
Were not attained by sudden flight, but they, while their companions slept, were struggling upward in the night.—Henry W. Longfellow

24-Point

6A \$1.80 13a \$1.80 \$3.60

REFINED, DIGNIFIED AND ARTISTIC
Puritan, a type for metropolitan and country printers
For body and display work it is very distinctive 457

30-Point

6A \$2.40 12a \$2.40 \$4.80

LANDING OF THE GOOD SHIP
Mayflower at Plymouth Rock in the year of
our Lord sixteen hundred and twenty 1620

THE H. C. HANSEN TYPE FOUNDRY



THE PURITAN SERIES

Standard Line

36-Point

4A \$2.60 8a \$2.40 \$5.00

BERKSHIRE ORNAMENTS Cannot fail to please your customers

MY WORK

Let me but do my work from day to day,
 In field or forest, at the desk or loom,
 In roaring market place or tranquil room:
 Let me but find it in my heart to say,
 When vagrant wishes beckon me astray—
 "This is my work; my blessing, not my doom.
 Of all who live I am the one by whom
 This work can best be done in the right way."
 Then shall I find it not too great nor small,
 To suit my spirit and to prove my powers;
 Then shall I cheerful greet the laboring hours,
 And cheerful turn, when the long shadows fall,
 At eventide to play and love and rest,
 Because I know for me my work is best.
 —Henry Van Dyke

Percival Macbeth

Algernon Launcelot

MACBETH & LAUNCELOT
 WHOLESALE JEWELERS

197 Lauriat Avenue
 Norwalk, Ohio

Presented by
 J. A. MAHN

SET WITH HANSEN'S
 BEVELED QUADS



The Sign of
Hansen Superior
Quality

Marshall Manufacturing Co.
 Fine Wall Papers
 179-181 Commonwealth Street
 Boston, Mass.

12-PT. BORDER NO. 182, 48 INCHES 64 INCHES \$1.50

<p style="font-size: 2em; font-weight: bold;">The Puritan Series</p> <p>Is of Hansen's Superior Quality which is a guarantee of its accuracy and durability</p>	<p style="font-size: 2em; font-weight: bold;">A</p> <p>Series of Type that will prove profitable and popular because of its pleasing tone and graceful freedom of design found hitherto only in hand lettered work of artist-engravers</p>
--	---

4-PT. HALF TONE RULE NO. 868, 26C. PER FT.

48-Point

3A \$4.15 6a \$3.35 \$7.50

HALFTONE RULE Is attractive and original 4

THE H. C. HANSEN TYPE FOUNDRY



THE PURITAN SERIES

Standard Line



SONG RECITAL

BY PUPILS OF
MISS EVA MURIEL BROWN

Assisted by
MISS MAE DOW, Reader

Program

- | | |
|----------------------------|-----------------|
| Flowers of Springtime | Busch |
| Miss Caroline Mortimer | |
| When I Look Into Your Eyes | Grey |
| Miss Gwendolyn DeLight | |
| Reading | Selected |
| Miss Mae Dow | |
| Nature's Melodies | Frost |
| Master Ellsworth Piper | |
| Loch Lomond | Old Scotch Song |
| Miss Margaret Cameron | |

March 31
1908

Symphony Ornament No. 68, 60c

Johnston & Kinsman
JEWELERS
and Silversmiths

Offer the finest line of Gold and Silver Jewelry, Precious Stones, Watches, Cut Glass, and Hand Painted China in great variety at prices that are within reach of all Gold and Silver Loving Cups and Presentation Gifts from Original Designs a Specialty

269-271 Massachusetts Avenue
Providence, Rhode Island

12-Pt. Croix Border No. 313, 54 inches \$1.50

In Beautiful New England

A Series of Four Lectures Given under Auspices of
Illustrated by Stereopticon The Appalachian Club

Paul Revere Hall, Boston, Massachusetts
October 1, 8, 16 and 22

Card of Admission to Entire Series, Two Dollars

For Good Printers, Everywhere

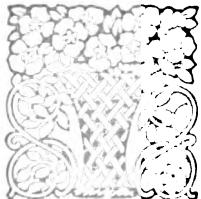

This Foundry manufactures an assortment of distinctive Type Faces, Brass Rule, Borders and Ornaments that are unexcelled and that will facilitate the production, in an economical manner, of printing of quality—the kind that escapes the waste basket and is profitable for both the printer and his customer. 'Tis quality that counts

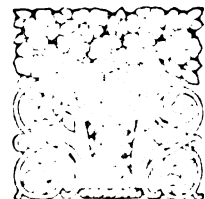

The H. C. Hansen Type Foundry, & Boston

12-Pt. Swastika Outline Border, 54 inches \$1.50

Berkshire Ornaments No. 251, each, 40c

THE H. C. HANSEN TYPE FOUNDRY



THE PURITAN SERIES

Standard Line

8-Point

CHEAPEST LABOR. SAY THE PRUDENT

Is the dearest labor. What we buy in a broom, a mat, a wagon, a knife, is some application of good sense to a common want. It is best to pay in your land a skilful gardener, or to buy good sense applied to gardening; in your sailor good sense applied to navigation; in the house, good sense applied to cooking, sewing, serving; in your agent, good sense applied to accounts and affairs. So do you multiply your presence, or spread yourself throughout your estate. But because of the dual constitution of things, in labor as in life, there can be no cheating. The thief steals from himself. The swindler swindles himself. For the real price of labor is knowledge and virtue, whereof wealth and credit are signs.—Ralph Waldo Emerson

10-Point

CHEAPEST LABOR. SAYS THE

Prudent, is the dearest labor. What we buy in a broom, a mat, a wagon, a knife, is some application of good sense to a common want. It is best to pay in your land a skilful gardener, or to buy good sense applied to gardening; in your sailor, good sense applied to navigation; in the house, good sense applied to cooking, sewing, serving; in your agent, good sense applied to accounts and affairs. So do you multiply your presence, or spread yourself through

12-Point

THE PURITAN
IS UNEXCELLED
FOR DAINTY
CATALOGS
AND
BOOKLETS



For Job Font Schemes and
Prices see pages 62 and 63

THE MT. DOWAKEUP HOUSE

THE Mt. Dowakeup House, the most delightful of summer resorts in New England, is situated on the slope of Mt. Dowakeup in the delightful little Vermont town of Berryvale, in the heart of the world-renowned Green Mountain Range. The hotel is on the eastern slope of the mountain where the invigorating rays of the morning sun, the cool shadows of the afternoon, the merry voices of song-birds, the soft murmur of the wind among the branches of the surrounding forest trees, and the landscape presenting to the vision a panorama with the soft, rich coloring of Nature, forming a picture of sublime magnificence which words are inadequate to describe, combine to make this the ideal place for rest and recreation for young and old. AMUSE- In the matter of amusements, this MENTS place offers a variety of attractions which are seldom to be found at any one resort. The golf links are as perfect as human skill and natural advantages can produce; free use of boats on the lake at the base

THE IDEAL
LETTER FOR THE
BETTER GRADE
OF
COMMERCIAL
WORK



Another of the Hansen's
Quality Productions

12-Pt. University Border. 54 inches \$1.50

THE H. C. HANSEN TYPE FOUNDRY

STRATFORD OLD STYLE

Standard Line

6-Point

24A \$1.00 48a \$1.00 \$2.00

STRATFORD-ON-AVON has the proud distinction of being the birthplace of William Shakespeare, and the house in which the great poet was born and spent his earlier years is still standing in Henley street. As years passed by it underwent many changes, but its appearance now is doubtless not materially different from what it was in the latter part of the sixteenth century, since it has been carefully and reverently preserved as a national memorial to the poet. There are a few houses of the same period and the same class still standing in Stratford and its vicinity. Stratford is a very ancient town, its name showing that it was situated at a ford on a Roman street or highway between London and Birmingham. It stands on the western bank of the Avon, called "The Poet's River." To-day the most imposing buildings in Stratford are the Shakespeare Memorial Theatre and the Church of the Holy Trinity. In this church lie the remains of William Shakespeare. But the most enduring monument to his greatness are his works, which are read in all portions of the civilized globe. Quotations from them abound in wisdom:

"If to do were as easy as to know what were good to do, chapels had been churches and poor men's cottages princes' palaces. It is a good divine that follows his own instructions: I can easier teach twenty what were good to be done, than be one of the twen

10-Point

18A \$1.20 36a \$1.50 \$2.50

STRATFORD-ON-AVON has the distinction of being the birthplace of William Shakespeare, and the house in which the great poet was born and spent

his earlier years is still standing in Henley street. As years passed it underwent many changes, but its appearance now is doubtless not materially different from what it was in the latter part of the sixteenth century, since it has been carefully and reverently preserved as a national memorial to the poet. There are a few houses of the same period and the same class still standing in Stratford and its vicinity. Stratford is a very ancient town, its name showing that it was situated at a ford on a Roman street or highway between Lon-

8-Point

20A \$1.10 40a \$1.15 \$2.25

STRATFORD-ON-AVON has the proud distinction of being the birthplace of William Shakespeare, and the house in which the great poet was born and spent his earlier years is still standing in Henley street. As the years passed it underwent many changes, but its appearance now is not materially different from what it was in the latter part of the sixteenth century, since it has been carefully and reverently preserved as a national memorial to the poet. There are a few houses of the same period and the same class still standing in Stratford and its vicinity. Stratford is a very ancient town, its name showing that it was situated at a ford on a Roman street or highway between London and Birmingham. It stands on the western bank of the Avon, called "The Poet's River." To-day the most imposing buildings in Stratford are the Shakespeare Memorial Theatre and the Church of the Holy Trinity. In this church lie



BIRTHPLACE OF SHAKESPEARE AT STRATFORD

12-Point

15A \$1.35 32a \$1.40 \$2.75

STRATFORD-ON-AVON has the proud distinction of being the birthplace of Shakespeare, and the house

in which the great poet was born and spent his earlier years is still standing in Henley street. As years passed by it underwent many changes, but its appearance now is doubtless not materially changed from what it was in the latter part of the sixteenth century, since it has been carefully and reverently preserved as a national memorial to the poet. An

18-Point

9A \$1.50 18a \$1.75 \$3.25

WHICH, MELLOW'D BY THE STEALING HOURS of time, will well become the seat of majesty and make us, no doubt, happy by his reign. The right and fortune of his happy stars; which God defend that I should wring

THE H. C. HANSEN TYPE FOUNDRY



STRATFORD OLD STYLE

Standard Line

24-Point

5A \$1.50 12a \$2.00 \$3.50

WHERE THE MUSIC CHARMS US
And the zephyrs woo us to repose, in the
shady nooks beside the rippling stream 16

30-Point

5A \$2.25 8a \$2.00 \$4.25

HEARING LOUD APPLAUSE
Reminds us of the time when the
political rally was held in Ward 3

36-Point

4A \$2.80 6a \$2.20 \$5.00

STRATFORD-ON-AVON
Birthplace of Shakespeare 8

48-Point

4A \$4.25 6a \$3.25 \$7.50

GOOD JUDGMENT
Stratford Old Style 47

Stratford Paragraph Marks, \$1.00 per font

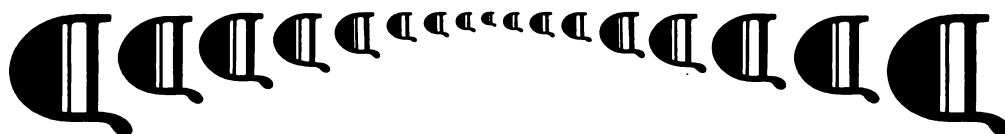

Special characters not in job fonts. See page 69.

Old Style figures furnished if desired

THE H. C. HANSEN TYPE FOUNDRY

STRATFORD OLD STYLE

Standard Line

The Chandler & Price Gordon Press

Absolutely parallel seats for paper and type reinforced by masses of metal. Time in make-ready saved & building up against springing unnecessary.

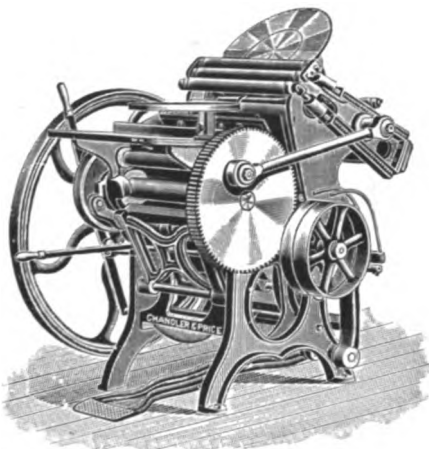

Heavy squeeze possible. Extra ink not demanded. Type has perfect back. Even impression, no undue wear. Nicely adjusted parts and Platen dwell. Increase feeder's speed. Save stock.

Carried in stock and sold by *The* H. C. Hansen
Type Foundry, 190-192 Congress Street, Boston

12-Pt. Border No. 222. 54 in. Font \$1.50

WILLIAM SHAKESPEARE

THE greatest of English poets, it is often said, is but a name. "No letter of his writing, no record of his conversation, no character of him drawn with any fulness by a contemporary," have been extracted by antiquaries from the piles of rubbish which they have sifted. Yet of no person is there a clearer picture in the popular fancy. You seem to know Shakespeare — to have seen Shakespeare — to have been friends with Shakespeare. We would attempt a slight delineation of the popular idea which has been formed, not from loose tradition or remote research, not from what some one says some one else said that the poet said, but from data which are at least undoubted, from the sure testimony of his certain works. Some extreme sceptics, we know, doubt whether it is possible to deduce anything as to the author's character from his works. Yet surely people do not keep a tame steam engine to write their books; and if those books were really written by a man, he must have been a man who could write them; he must have had the thoughts which they express,

8-Pt. Stratford O. S. shown as body letter

WILLIAM SHAKESPEARE

THE greatest of English poets, it is often said, is but a name. "No letter of his writing, no record of his conversation, no character of him drawn with any fulness by a contemporary," have been extracted by antiquaries from the piles of rubbish which they have sifted. Yet of no person is there a clearer picture in the popular fancy. You seem to know Shakespeare — to have seen Shakespeare — to have been friends with Shakespeare. We would attempt a slight delineation of the popular idea which has been formed, not from loose tradition or remote research, not from what some one says some one else said that the poet said, but from data which are at least undoubted, from the sure testimony of

10-Pt. Stratford O. S. shown as body letter

THE H. C. HANSEN TYPE FOUNDRY



STRATFORD OLD STYLE

Standard Line

The H. C. HANSEN TYPE FOUNDRY

B BORDERS, ORNA-
MENTS, LEADS
SLUGS, BRASS RULE

Type

P PRESSES, PAPER
CUTTERS, INKS
CASES, STANDS, ETC.

190-192 Congress Street
Boston, Massachusetts

The Very Best for the Man Who Prints
New York Branch, 43 Centre St.

Sold to _____

Date _____

H. G. WASHBURN

M. A. BROWNE

Eastman's Hand-Made Furniture

Eastman's Hand-Made Furniture is built to last for generations. Every detail of construction inside and outside is made by master artisans whose workmanship has stood the test of time.

Its exclusive elegance of pattern and beauty of finish fulfil the most exacting demands and give an individuality to the home not obtained with ordinary furniture.

Other furniture may be had which will give good service but there is none which combines the splendid cabinet work, the artistic design and the richness of grain and finish that characterize the Eastman productions.

Send for our booklet,
"Eastman Hand-Made Furniture."

COBB-EASTMAN COMP'Y
WASHINGTON STREET

H. G. WASHBURN & Co.

MANUFACTURERS' AGENTS FOR THE
Scenic Cameras

686 AMARYNTH STREET
Maplewood

Special Characters

To enable the printer to liven up his page and give his work that sketchy appearance that is always so desirable, we have designed special characters to be used with our Stratford Old Style. These characters are put up in suitable fonts, each size separately, from 6 to 48-point inclusive.

A M N R & 
r y The and of

6, 8, 10-point, 35 cents each. 12, 18-point, 50 cents.
24-point, 60 cents. 30, 36-point, 75 cents. 48-point,
\$1.00. "There is no need of being homlier than we
have to be," therefore get these characters at once.
They will add individuality to your work.

THE H. C. HANSEN TYPE FOUNDRY

CRAWFORD

Standard Line

6-Point

25A \$1.00 50a \$1.00 \$2.00

LIBERTY IN SOME COUNTRIES IS A KIND OF CHARADE WORD
An anagram, a symbol representing an imaginary quantity, a password invented by unhappy men to express all that they do not possess; a term meaning in the mind of slaves a conglomerate of conditions so absurd, of aspirations so futile, of imaginary delights so fantastically unreasonable, that if the ideal state of which the chained dreamers rave were realized but for one moment, humanity would start in amazement at the first glimpse of so much monstrosity, and by and by would hold its sides with laughter at the folly of its deluded fellows. In most countries where liberty is talked of it is but a dream, and such a dream as could only occur to the sickened fancy of 1234

8-Point

18A \$1.10 36a \$1.15 \$2.25

THE ENLARGED ROTUNDA SPACE HAS MADE IT
possible to provide another plate-glass view window facing the Notch. Fine Tennis Court, Ball Ground and Golf Links on the hotel grounds. The hotel itself is conducted upon the most liberal scale. The cuisine is of the best and accommodations up-to-date in every respect. Homelike and comfortable is the atmosphere of this popular house. Contains three hundred rooms with modern improvements. All 45

10-Point

18A \$1.10 36a \$1.40 \$2.50

THE CRAWFORD HOUSE IS SITUATED
Almost two thousand feet above the sea level, at the entrance to Crawford Notch, and boasts a position unequalled. Saco Lake in front, and Ammonoosuc Lake in the rear, mark the rise of the two famous rivers bearing these names. Here starts the original "Bridle Path" over the Presidential Range to the summit of Mt. Washington and only a mile and a half away is the Summit

12-Point

15A \$1.35 32a \$1.40 \$2.75

TO SUMMIT OF MT. WASHINGTON
By carriage road through various windings and picturesque scenery is a beautiful trip for summer tourists, and when taken once, it is never to be forgotten, and every succeeding year adds more and more to this great summer trip. Automobiles and 375

The
**Crawford
House**



OPEN FOR SUMMER
SEASON OF 1909

**Kimball, Anderson
& Young Company**

6-1/2" Border No. 361. 60 in. Font, \$1.50
Ornament No. 708. 35 cts. each

14-Point

12A \$1.50 24a \$1.50 \$3.00

TWIN MOUNTAIN HOUSE
Is located in the most picturesque part of New Hampshire, near the Crawford Notch, with exquisite views of surrounding scenery 36

18-Point

10A \$1.75 20a \$1.50 \$3.25

TRAINS LEAVE DAILY
For the Crawford Notch and all points in New Hampshire where the tourist can revel in scenes of beauty and pass 47

20-Point

8A \$1.75 16a \$1.50 \$3.25

SUMMER VISITORS
to the White Mountains increasing every year and the Crawford House 125

THE H. C. HANSEN TYPE FOUNDRY



CRAWFORD

Standard Line

48-Point

4A \$4.35 5a \$2.90 \$7.25

THE CRAWFORD Is the Leading Face

42-Point

3A \$3.15 6a \$2.85 \$6.00

THE HOTEL SUITES Have Many Guests 175

36-Point

4A \$2.75 6a \$2.25 \$5.00

PERFECT RULE DESIGN Everything for the Printer 237

30-Point

4A \$2.00 9a \$2.25 \$4.25

IDEAL TYPES FOR PRINTERS Found at Hansen's, 190 Congress St.

24-Point

6A \$1.75 12a \$1.75 \$3.50

DISPLAY LINE SET IN CRAWFORD

Best all around letter for every day use and
12345 may be used for booklets 67890

THE H. C. HANSEN TYPE FOUNDRY



FRANK V. HENDERSON

CRAWFORD LETTER IN DISPLAY

GEORGE CRAWFORD

James Henderson & Sons Red Lion House

University Press Warehouse
York House, Portugal Street

RIDGEWAY-THAYER CO.
UNION SQUARE
NEW YORK

THE H. C. HANSEN TYPE
190-192 CON
BOSTON

M

HOUGHTON, MIFFLIN

THE RIVERSIDE PRESS

Special and Limited
Editions of Books

Salesroom, 4 Park Street
Boston, Massachusetts

Balzac

WE want you to see the Library Edition of Balzac. You can't come to our store very well, unless you live in New York, and even then you would have no time for adequate examination. You cannot get acquainted with Balzac by a cursory glance over a few of his books in a store. You can have no idea of the scope of the Comedie Humane—that unparalleled and complete panorama of life—without reading some of the inimitable stories that compose it. Humor and pathos, romance and serious study, problem novel and “Canterbury” tale—all are there. You can prove Balzac's ability to entertain you, and at the same time satisfy yourself regarding the merits of the Library Edition by filling in and mailing coupon. As an extra inducement for you to send in your order at once, we will present you with a beautiful copy of the English edition of Balzac's story, “A Street of Paris and Its Inhabitant.” This is the only English edition, published in de luxe form, with the original 32 superb color

SIEGEL-COOPER
NEW YORK BOSTON



CRAWFORD ITALIC

Standard Line

36-Point

4A \$2.40 9a \$2.60 \$5.00

*EVEN IN THE ART OF
Printing progress, though it
was continuous, was slow
for three hundred and fifty
years, and, though the vol-
ume of printed matter 259*

Complete sizes of this series in preparation. 6 to 48-Point. Send for specimen sheets

TITLE CONDENSED No. 75

Standard Line

24-Point

9A \$1.70 16a \$1.80 \$3.50

THE ART OF PRINTING, THE PROGRESS
though continuous, was slow for three hundred
and fifty years, and, though the volume of prin-
ted matter has increased much more rapidly
during the last half century, responsive to the
conditions of our age, the use of printing is
still very largely a matter of habit and educa-

ABCDEFGHIJKLMN OPQRSTUVWXYZ&

12345 abcdefghijklmnopqrstuvwxyz 67890

THE H. C. HANSEN TYPE FOUNDRY

THE HAMPTON SERIES**Standard Line**

6-Point 22A \$0.90 44a \$1.10 \$2.00

**LIBERTY IN SOME COUNTRIES IS A KIND OF CHARADE WORD, REPRESENTING AN IMAGINARY QUANTITY, INVENTED
By unhappy men to express all that they do not possess, a term meaning in the mind of slaves
a conglomerate of conditions so absurd, of aspirations so futile, of imaginary**

8-Point 18A \$1.00 36a \$1.25 \$2.25

THE NEW HAMPTON SERIES should have the attention of every up-to-date printer

10-Point 16A \$1.10 32a \$1.40 \$2.50

**HAMILTON WOOD GOODS
carried in stock by The H. C. Hansen
Type Foundry**

12-Point 15A \$1.20 30a \$1.55 \$2.75

**METAL QUOTATIONS
cast on a type machine are the
kind that Hansen makes**

14-Point 12A \$1.90 24a \$1.70 \$3.00

FACES AND ORNAMENTS that are always new and original

18-Point 9A \$1.50 17a \$1.75 \$3.25

**THE H. C. HANSEN TYPE FOUNDRY excel in all their
products**

24-Point 6A \$1.50 12a \$2.00 \$3.50

PROMPTNESS and reliability pays

30-Point 5A \$2.10 8a \$2.15 \$4.25

ADVERTISE with good printing

36-Point 4A \$2.50 6a \$2.50 \$5.00

SUPERIOR values given

42-Point 3A \$2.90 6a \$3.35 \$6.25

A STRONG type face 2

48-Point 3A \$4.00 5a \$3.50 \$7.50

GREAT display 854

THE H. C. HANSEN TYPE FOUNDRY

THE HAMPTON SERIES



BERKSHIRE ORN. NO. 259

THE H. C. HANSEN TYPE FOUNDRY
ESTABLISHED 1872
190-192 CONGRESS STREET, BOSTON
43 CENTRE STREET NEW YORK

6-Point 22A \$0.90 44a \$1.10 \$2.00

GOOD PRINTING IS OFTEN MARRED BY IMPERFECT JOINING OF RULES AT CORNERS. NO MATTER HOW Well mitered the rules may be, it seems that failure to secure perfect join is the rule rather than the exception. A simple and inexpensive method of obtaining perfect joints is by use of corner quads made by this foundry from both solid brass and type metal. The use of Hansen's Complete Mitering Machine in cutting miters will eliminate all trouble in securing perfect miters, which, locked with corner quads give perfect

8-Point 18A \$1.00 36a \$1.25 \$2.25

HAMPTON COURT PALACE, THE BIRTHPLACE Of Edward VI, was the principal residence of English sovereigns for many years. It is now occupied by persons of rank, but its picture gallery, state apartments and the gardens are open to the public free of charge. Included among the pictures in the gallery are many fine specimens of the work of old masters 6

10-Point 16A \$1.10 32a \$1.40 \$2.50

AMONG THE MANY FINE RESIDENCES IN THE VICINITY OF Garrick Villa, formerly, under the name of Hampton House, the residence of Garrick the famous actor. In the neighborhood are a number of large pumping works for supplying London with water. Abounding in places of historic \$2480

12-Point 15A \$1.20 30a \$1.55 \$2.75

HAMPTON COURT PALACE, CLOSE BY THE RIVER, IS One of the finest extant specimens of the Tudor style of architecture, and was formerly a royal residence. It was erected by Cardinal Wolsey, who, in 1515, received a lease of the old mansion and grounds for 99 years. 47

14-Point 12A \$1.30 24a \$1.70 \$3.00

THE SPLENDOR OF THE BUILDING SEEMED TO Awaken the cupidity of Henry VIII to such an extent that Wolsey, in 1525, thought it prudent to make him a present of it. It became Henry's favorite residence, and he made additions 1527

18-Point 9A \$1.50 17a \$1.75 \$3.25

FINE GARDENS WERE LAID OUT DUTCH STYLE With elevated terraces, long, shady walks, and a labyrinth called "Maze" which is a source of great amusement to the throngs of visitors 8653

Bold and

Much has been advertising expense trade journals on lower case lettering. With have produced a

Hampton

A type face in which the lower case are strong and readable. The figures and designed with a this a most proof in durability and

Fine Type

ton Series

STANDARD LINE

**The H. C. Hansen
Type Foundry**
Boston New York

42-Point

3A \$2.90 6a \$3.35 \$6.25

INCREASE IN SALES Result of Publicity 98

1 Legible

recently said by
arts in the leading
n the value of the
rs in display ad-
this in mind we
ad now offer the
n Series

hich the letters of
re of particularly
ble proportions.
capital letters are
view to making
table letter both
value in display
for Display

24-Point

6A \$1.50 12a \$2.00 \$3.50

SILK AND LINEN IMPORTERS Gather at Hotel Victor, Salem

30-Point

5A \$2.10 8a \$2.15 \$4.25

PRACTICAL TYPE FACE Printers and advertisers

36-Point

4A \$2.50 6a \$2.50 \$5.00

INDUSTRIOUS MAN Acquires the coin 59

48-Point

3A \$4.00 6a \$3.50 \$7.50

QUAINT CUSTOM Peculiar to Orient

Great Red Tag Sale

Lot No. 18753

Central Dry
Goods Co.

~~\$6.00~~

Red Tag Sale
Price

\$3.98

A Money-Saving Opportunity

For One Week Only

We offer at greatly reduced prices, a fine line of goods which a backward season has left on our shelves. We lose, you gain. Watch for the prices

OPEN EVENINGS DURING THIS SALE

Money saved is money earned

Central Dry Goods Company



Sail Away

From cares and worry
Spend your vacation at

The
Pontiac House
Northport, Me.

Boating, Bathing
Fishing, Driving
Golf and Tennis

Cuisine and Service
Unexcelled

MacDonald & Andrews
Proprietors

Write for Booklet

**"Thistle Brand"
Collars**

4-PLY LINEN



GUARANTEED

Size _____

Style _____

Lot _____

ALEPPO ORN. NO. 7
SET WITH HANSEN'S BEVELED QUADS

**THE H. C. HANSEN
TYPE FOUNDRY**

ESTABLISHED 1872

BOSTON

NEW YORK

The Hampton Series

Display set in Hampton Series
 Body type: National Roman
 72-Pt. Aladdin Ornament No 7, 55c.
 48-Pt. Phone Ornament, 20c.
 10-Pt. Halftone Brass Rule, No. 675
 18-Pt. Halftone Brass Rule No. 661

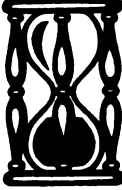

COLT'S SUPERIOR FURNITURE

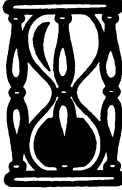

**Hand-made
Mission and Colonial
Designs**

COLT MANUFACTURING CO.
BOSTON DETROIT CHICAGO



The Twentieth Century Necessity Acme Telephones

The Acme Telephone is an automatic system which is invaluable in hotels, factories and in every place where a private telephone system is desirable. The instruments are neat and compact and are easily installed. Their use will save time and money and will enable superintendents and managers to keep in touch with every department without leaving their desks. They are inexpensive

Write To-day for Descriptive Catalog "B"

The Wilkie Electric Mfg. Co.
 1295 Heatherwood Avenue, Manchester, New Jersey



The H. C. Hansen Type Foundry

Boston, Mass.
New York City

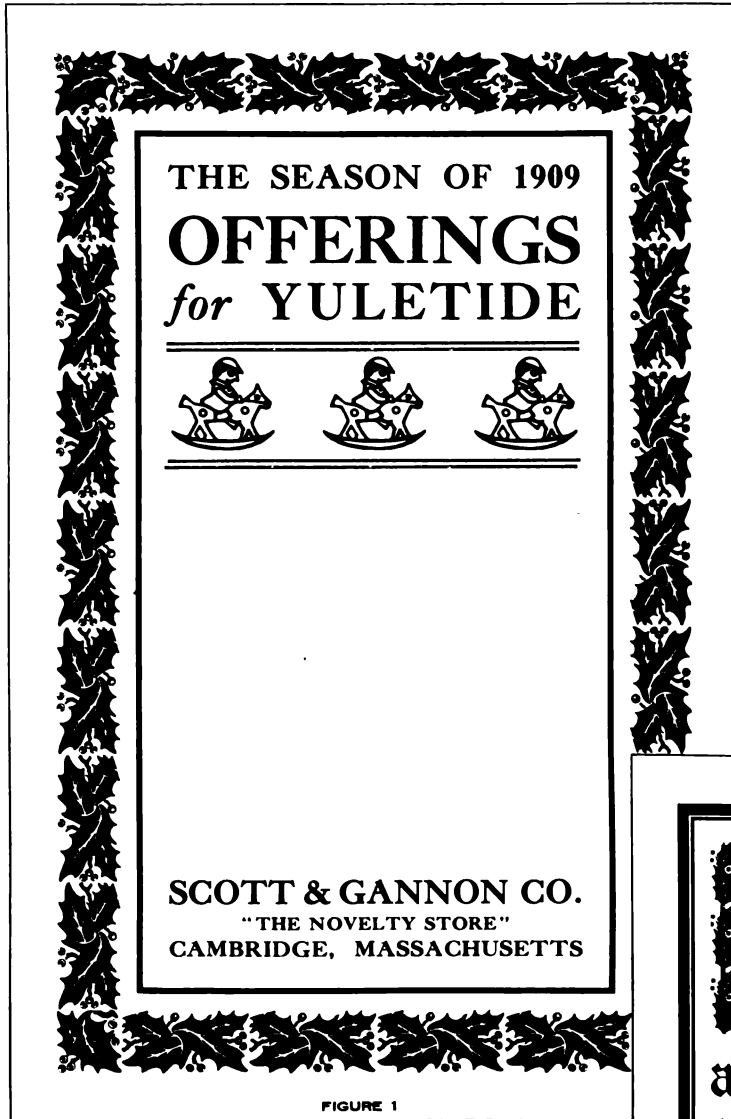

FIGURE 1

FIGURE 1
 SET IN CASLON FULLFACE
 24-PT. HOLLY BORDER NO. 2, ONE COLOR, 36 INCHES, \$2.50
 TWO COLORS, 18 INCHES EACH COLOR, \$2.50
 PRINTERS' JOYS NO. 11, 10C. EACH

FIGURE 2
 SET IN LAFAYETTE TEXT, SYLPH INITIALS
 12-PT. HOLLY BORDER ONE COLOR, 54 INCHES, \$1.50
 TWO COLORS, 27 INCHES EACH COLOR, \$1.50
 36-POINT HOLLY BORDER NO. 1, ONE COLOR, 36 INCHES, \$3.00
 TWO COLORS, 18 INCHES EACH COLOR, \$3.00
 24-PT. SWASTIKA ORNAMENT NO. 10, 36 INCHES, \$1.85
 24-PT. SWASTIKA OUTLINE ORNAMENT NO. 11, 36 INCHES, \$1.85



HOLLY WREATH NO. 1
 ONE COLOR, 40C. TWO COLORS, 80C.

For the Holidays

And for every day of the year
 our Borders and Ornaments are
 attractive and appropriate

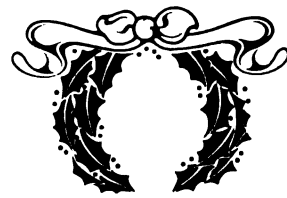

HOLLY WREATH NO. 2
 ONE COLOR, 45C. TWO COLORS, 90C.

A Greeting
 Time changes
 and we with time
 but good friendship
 changes only by in-
 creasing in value
 This is my thought
 as I now send you
 best wishes for a
 very, very Merry
 Christmas

FIGURE 2



Lining Tudor Black No. 3

Standard Line

48-Point

3A \$4.20 6a \$3.50 \$7.70

Every Devoted Gift 23

42-Point

4A \$3.60 6a \$2.80 \$6.40

Beautiful Paintings Sold

36-Point

4A \$2.70 7a \$2.30 \$5.00

Handsomely Decorated Ceilings

30-Point

4A \$2.00 10a \$2.30 \$4.30

Artistic Designs

24-Point

5A \$1.65 13a \$1.85 \$3.50

King Tudor Receives

18-Point

7A \$1.50 18a \$1.75 \$3.25

Resolutions Written and 8 Finely Printed 9

12-Point

10A \$1.15 30a \$1.60 \$2.75

Tudor Black is Very Easy to Read 35 Graceful in Design 48

10-Point

10A \$0.95 36a \$1.55 \$2.50

This Foundry Makes Many Specialties 45 New Beveled Quotations 60

8-Point

15A \$0.95 40a \$1.30 \$2.25

At the Grand Opera House This Week Appear 34 World's Famous Skirt Dancers 78

6-Point

16A \$0.85 50a \$1.15 \$2.00

The Contemporaries of Great Artists Seek to Obtain Mastery 12 and Fame by Devoted Study and Hard Work 34

24-Point Tudor Black Ornaments, 60 cents per font



When ordering to match type in case, send Cap "H" and l.c. "m"

Recital

Given by Pupils of the

Bannertown High School

Assisted by

Miss Ethel Beaudet, Soprano
Miss Evelyn Lee, Reader
Mr. Geo. Grant, Tenor

Glen Academy Hall

Wednesday Evening
November the Tenth

THE H. C. HANSEN TYPE FOUNDRY

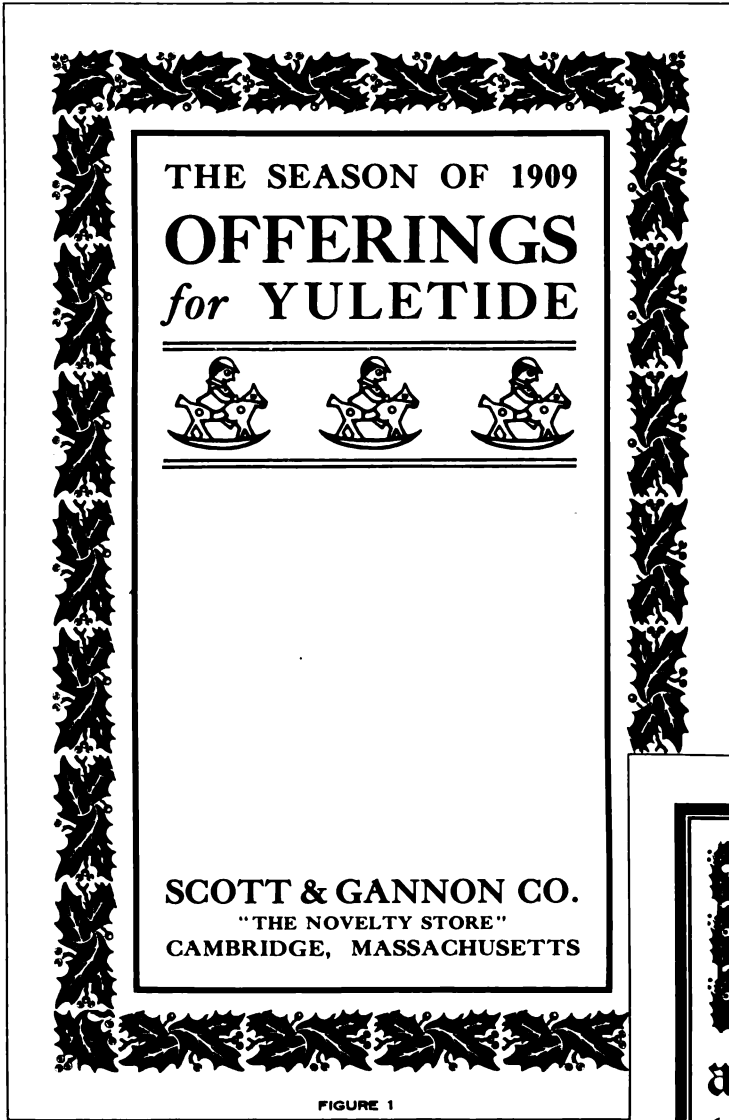

FIGURE 1

FIGURE 1
 SET IN CASLON FULLFACE
 24-PT. HOLLY BORDER NO. 2, ONE COLOR, 36 INCHES, \$2.50
 TWO COLORS, 18 INCHES EACH COLOR, \$2.50
 PRINTERS' JOYS NO. 11, 10C. EACH

FIGURE 2
 SET IN LAFAYETTE TEXT, SYLPH INITIALS
 12-PT. HOLLY BORDER ONE COLOR, 54 INCHES, \$1.50
 TWO COLORS, 27 INCHES EACH COLOR, \$1.50
 36-POINT HOLLY BORDER NO. 1, ONE COLOR, 36 INCHES, \$3.00
 TWO COLORS, 18 INCHES EACH COLOR, \$3.00
 24-PT. SWASTIKA ORNAMENT NO. 10, 36 INCHES, \$1.05
 24-PT. SWASTIKA OUTLINE ORNAMENT NO. 11, 36 INCHES, \$1.05



HOLLY WREATH NO. 1
 ONE COLOR, 40C. TWO COLORS, 80C.

For the Holidays

And for every day of the year
 our Borders and Ornaments are
 attractive and appropriate

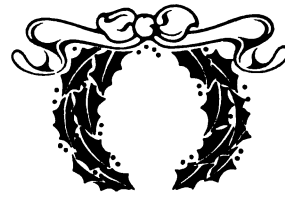

HOLLY WREATH NO. 2
 ONE COLOR, 45C. TWO COLORS, 90C.

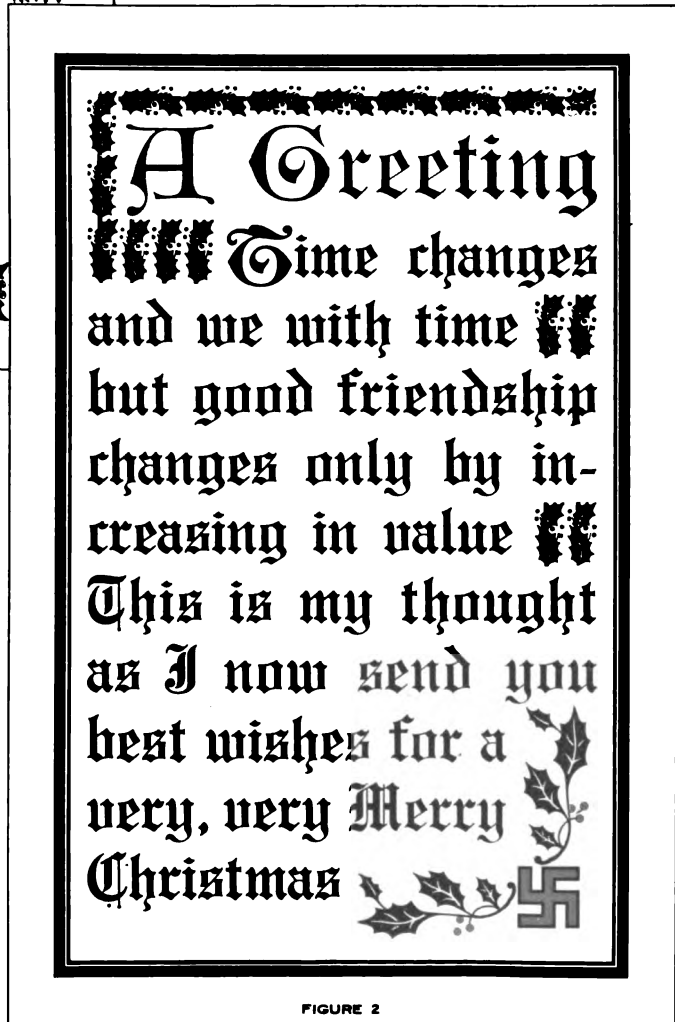

FIGURE 2

Lining Tudor Black No. 3

Standard Line

48-Point

3A \$4.20 6a \$3.50 \$7.70

Every Devoted Gift 23

42-Point

4A \$3.60 6a \$2.80 \$6.40

Beautiful Paintings Sold

36-Point

4A \$2.70 7a \$2.30 \$5.00

Handsomely Decorated Ceilings

30-Point

4A \$2.00 10a \$2.30 \$4.30

Artistic Designs

24-Point

5A \$1.65 13a \$1.85 \$3.50

King Tudor Receives

18-Point

7A \$1.50 18a \$1.75 \$3.25

Resolutions Written and
8 Finely Printed 9

12-Point

10A \$1.15 30a \$1.60 \$2.75

Tudor Black is Very Easy to Read
35 Graceful in Design 48

10-Point

10A \$0.95 36a \$1.55 \$2.50

This Foundry Makes Many Specialties
45 New Beveled Quotations 60

8-Point

15A \$0.95 40a \$1.30 \$2.25

At the Grand Opera House This Week Appear
34 World's Famous Skirt Dancers 78

6-Point

16A \$0.85 50a \$1.15 \$2.00

The Contemporaries of Great Artists Seek to Obtain Mastery
12 and Fame by Devoted Study and Hard Work 34

24-Point Tudor Black Ornaments, 60 cents per font



When ordering to match type in case, send Cap "H" and l.c. "m"

Recital

Given by Pupils of the

Bannertown High School

Assisted by

Miss Ethel Beaudet, Soprano
Miss Evelyn Lee, Reader
Mr. Geo. Grant, Tenor

Glen Academy Hall

Wednesday Evening
November the Tenth

THE H. C. HANSEN TYPE FOUNDRY

The Buffalo Series

Standard Line

36-Point

4A \$3.00 6a \$2.50 \$5.50

TYPE LEADS SLUGS

The Highest Standard 6

6-Point 19A \$1.00 38a \$1.00 \$2.00

INTELLIGENCE AND INDUSTRY
THE GREAT COMBINATIONS
Our capacity to produce has developed so enormously and our products have so multiplied that the problem of more markets requires urgent and immediate attention. Only broad and enlightened policy will keep trade on a basis whereby all countries will compete on the same footing, and all countries will then have the system that is used in the United States 24

8-Point 20A \$1.25 34a \$1.00 \$2.25

ENCOURAGE INDUSTRY
A System which provides mutual exchange of commodities is manifestly essential to continued, healthful growth of our export trade. We must not repose in security that we can forever sell everything and buy nothing. If such were the case then all the products coming from Foreign

6-Pt. Buffalo Border No. 4. 60 inches, \$1.50

10-Point

15A \$1.25 30a \$1.25 \$2.50

MACHINERY OF ALL KINDS ON HAND
Presses, Paper Cutters, Rule Curvers, and Mitering Machines. Type, Leads, Quotations, Slugs, Brass Rule, Cabinets, Stands, Frames, Racks, and in fact everything for the Printer who keeps Up-to-date. Orders receive our prompt and careful attention

12-Point

15A \$1.50 22a \$1.25 \$2.75

HARD & EXTRA-TOUGH METAL
used in productions of this foundry and great care is taken to insure accuracy. All Type made from this metal gives perfect satisfaction to printers in all branches of work. 2

14-Point

12A \$1.60 20a \$1.40 \$3.00

PRINTING OFFICE FURNISHINGS of every Description Supplied promptly at current prices Call at 190-192 Congress Street when you intend to buy goods and receive quick service on all

48-Point

3A \$4.75 4a \$3.25 \$8.00

RULE & Designs

Are Submitted 8

THE H. C. HANSEN TYPE FOUNDRY

The Buffalo Series

Standard Line

60-Point

3A \$8.20 4a \$4.80 \$13.00

TYPE Faces

18-Point

9A \$1.80 15a \$1.50 \$3.30

The HANSEN COMPLETE MITERING Machine. No office is complete without one. Saves time and money. **\$18.50**

24-Point

5A \$1.80 9a \$1.70 \$3.50

JUST SET BY A MERE PIN
There are no lines to guess at
Handle strikes a rubber tube

30-Point

5A \$2.50 8a \$2.00 \$4.50

GREAT ADVANTAGES
The rule holder has an
angle of ninety degrees

12-Point Twin Buffalo Border No. 6. 54 inches, \$1.50

72-Point

3A \$9.00 4a \$6.70 \$14.70

BIG display

THE H. C. HANSEN TYPE FOUNDRY

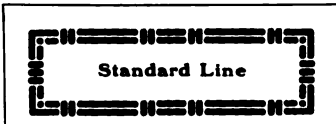

The Buffalo Series

Shown in Display

<p>Geo. Hill Chas. Hill</p>  <p>All Orders Receive Prompt Attention</p>	<h1>HILL BROTHERS</h1>
	<h2>HAND RAKE MANUFACTURERS</h2>
	<p>WEST PETERBORO & & MAINE</p>

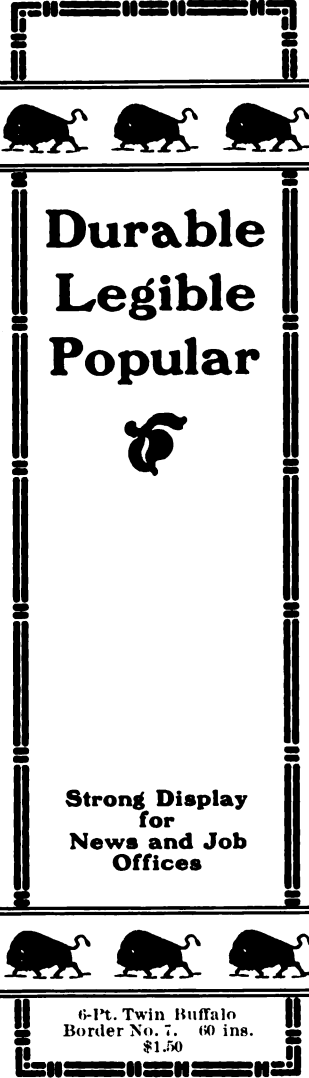

**Durable
Legible
Popular**



**Strong Display
for
News and Job
Offices**

6-Pt. Twin Buffalo
Border No. 7. 60 ins.
\$1.50

The
Sultan Shoe
 For Men and Women

For style and comfort the Sultan Shoe is unequalled. Made of best materials by skilled workmen in one of the best appointed and largest factories in this country. Made in the latest popular styles and sold direct to consumer for

\$3.50 to \$5.00

The Little Sultan Shoe
 For children. The best shoe in the world for comfort and protection of growing feet. Prices \$1.50 to \$2.75

Guaranteed and Sold by
Sultan Shoe Stores
 In All the Large Cities

Buffalo Italic

Standard Line

6-Point

20A \$1.00 40a \$1.00 \$2.00

HOW DEAR TO OUR HEARTS IS THE OLD SILVER Dollar, when some kind subscriber presents it to view—The liberty head without necktie or collar, and all the strange things that to us seem so new; the wide spreading eagle, the arrows below it, the stars and the words with the queer things they tell, the coin of our fathers! We're glad that we know it, for some time or other 'twill come in right well. The sentiment of the foregoing is shared by many men in many trades beside the editors of the rural districts \$14

10-Point

8-Point

18A \$1.15 36a \$1.10 \$2.25

GOOD PRINTING IS OFTEN MARRED BY THE Imperfect joining of rules at corners. No matter how well mitered the rules may be, it would seem that failure to secure perfect join is the rule rather than the exception. The use of corner quads, made by this foundry, is a simple and inexpensive method of obtaining perfect joints 18

14A \$1.25 32a \$1.25 \$2.50

**H. C. HANSEN TYPE FOUNDRY
A complete foundry manufacturing and selling type and printers' supplies of superior quality, at right prices 8**

12-Point

14A \$1.50 26a \$1.25 \$2.75

IN DAYS OF OLD, PRINTERS Made their own type and ink, their presses were crude and slow, and modern inking rollers were not so much as dreamed of. The use of

14-Point

10A \$1.60 20a \$1.40 \$3.00

UNDER THE SPREADING Chestnut tree is the forge of the village blacksmith. The aforesaid blacksmith is a 8

30-Point

4A \$2.25 8a \$2.00 \$4.25

**EARLY BIRD GETS WORM
Thus the old proverb reads 58**

18-Point

7A \$1.50 16a \$1.75 \$3.25

**MEMOIRS OF JANE
A thrilling tale of woe published in Germany in '52, now out of print**

24-Point

5A \$1.70 10a \$1.80 \$3.50

**DAYS OF REST
Down on the farm among the pines 7**

36-Point

4A \$3.00 5a \$2.00 \$5.00

**RARE DAYS IN JUNE
Anticipate yearly return**

48-Point

3A \$4.75 4a \$3.00 \$7.75

WHEAT Fields 5

THE H. C. HANSEN TYPE FOUNDRY

Buffalo Condensed

Standard Line

36-Point

5A \$2.60 8a \$2.40 \$5.00

**CANOES ARE ON THE RIVERS
Between Waltham and Riverside**

6-Point

26A \$0.90 60a \$1.10 \$2.00

THE SNOW HAD BEGUN IN THE EVENING AND BUSILY ALL THE NIGHT, HAD
Been heaping field and forest with a silence deep and white. I thought of the mound
at Mount Auburn where a little headstone stood, how the snowflakes were covering
gently, as did the robins, the Babes in the Wood. The fire was made to brighten
all; the cinders on the hearth cast no reflections on the earth where violets grow.
And under the sod and the dew, waiting the judgment day, under the laurel the 26

8-Point

25A \$1.00 50a \$1.25 \$2.25

THE MILL WILL NEVER GRIND WITH THE WATERS THAT HAVE
Passed. Listen to the water-mill the whole livelong day; how the
clanking of its wheels wears the hours away, and a proverb haunts
my mind, as a spell is cast, the mill will never grind again with the
waters that have passed. Languidly the Autumn wind stirs the

10-Point

20A \$1.20 40a \$1.30 \$2.50

THE PRETTY PICTURES OF THE GIBSON GIRLS
Are published all over the world, and in England
they sell as fast as hot muffins. No shop is com-
plete without the series of Gibson Pictures. 35689

12-Point

18A \$1.30 32a \$1.45 \$2.75

IN THE CLIME OF SUMMER TIME, WHEN
Lights were dim and low, and breezes stirred
the Autumn leaves when the evening sun
was low, and harvesters coming through the

14-Point

16A \$1.35 32a \$1.65 \$3.00

IN MY OLD NEW HAMPSHIRE HOME
Amid its pleasant surroundings, I seem
to be with old friends once again 482
The Old Home Week is held every year

48-Point

4A \$3.85 6a \$3.40 \$7.25

**MADE BY H·C·HANSEN
Independent Type 480**

THE H. C. HANSEN TYPE FOUNDRY

80

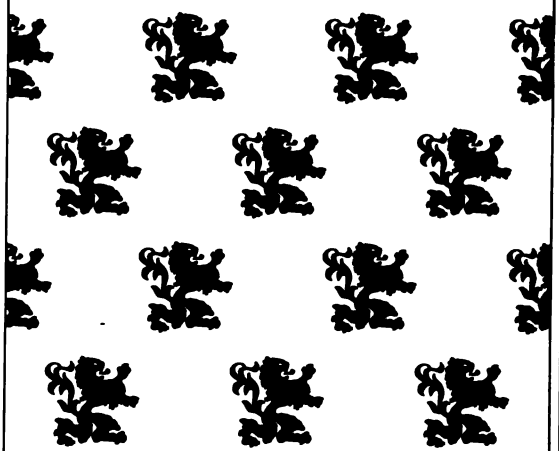
**The Story of a
Modern Griffin**

Published at Birmingham by
The Medieval Architectural
League and intended for the
use of Students and others



Buffalo Condensed

Standard Line

72-Point

3A \$6.10 4a \$4.15 \$10.25

Our own BAND

30-Point

5A \$1.85 11a \$2.40 \$4.25

**THE PINE GROVE PICNIC GROUND
Engaged for the Annual Outing 98
Appreciated by the leading Artists**

18-Point

10A \$1.45 22a \$1.80 \$3.25

24-Point

7A \$1.70 13a \$1.80 \$3.50

**A PLEASANT TRIP TO
the grounds on the com-
modious Steamer Violet
passing several points of
historical interest. One
of the most beautiful trips
along the coast. 1234589**

**DINNER IS SERVED
The Hotel Vere, near
the Picnic Grounds.
Round Trip Tickets,
One Dollar Bill \$1.00**

12-Point Buffalo Border No. 3, 54-inch font, \$1.50

60-Point

3A \$5.50 5a \$4.00 \$9.50

GRAND OUTINGS Come and Enjoy

THE H. C. HANSEN TYPE FOUNDRY

Buffalo Outline

Standard Line

48-Point

3A \$4.75 4a \$3.25 \$8.00

Brass RULES 2

12-Point

15A \$1.50 22a \$1.25 \$2.75

ACME OF PERFECTION
Attained only after years
of experience. All expert
workmen are employed
in the different branches
of the Hansen Foundry.



14-Point

12A \$1.60 18a \$1.40 \$3.00

THE PLAIN RULES
Will beautify and also
strengthen all kinds
typographical work
The Fancy Rules for
special purposes 126

18-Point

9A \$1.80 15a \$1.50 \$3.30

IN THE FRONT RANK
Let all others follow. The
finest ever. The Buffalo
Outline Registers exact in
all the sizes. Made in the
Hansen Type Foundry 68

24-Point

5A \$1.80 8a \$1.70 \$3.50

A FINE OUTLINE
for a light, delicate
effect is very neat.
Look for the results
on specimen sheet

30-Point

5A \$2.50 8a \$2.00 \$4.50

BORDERS & ORNAMENTS
of very many designs 14580

36-Point

4A \$3.00 6a \$2.50 \$5.50

A SECTIONAL CASE
Rules for Printers use

THE H. C. HANSEN TYPE FOUNDRY

PARSIFAL

A·MYSTICAL·DRAMA·BY·RICHARD·WAGNER·RETOLD·IN·THE·SPIRIT·OF·THE·BAYREUTH·INTERPRETATION·BY·HUCKEL

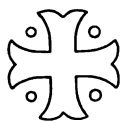

CROWELL·BAYNARD·CO
PUBLISHERS·NEW·YORK

s & Pond ianos.

catalogue will be sent to all
gining. It contains beautiful
res of new grands especially
esigned for the trade. Their
y case designs are a thing of
auty, grace and elegance and
artistic musical pianos more
d nearly approach perfection
never been equalled. While
he first cost is hardly greater
instruments, Ivers and Pond
ultimately proves economical
stand as long as the average
here we have no dealers we
t from the Boston warerooms
old pianos taken in exchange

MOND PIANO CO.,
ton St., Boston, Mass.

HENRY

only about a year since the
drollest and most mirth-provoking stories of South and Central American life began
to appear in McClure's Magazine. At once the author was hailed as the new American
humorist worthy of comparison with Bill Nye and Mark Twain. These sketches
have now been brought together by Mr. Henry, and woven into a novel entitled

Cabbages and Kings

This is the most amusing book of the season and will be bought by everyone who
enjoys a long succession of hearty laughs. Mr. Henry has opened a wholly new vein
and his stories have been the event of the month when they have appeared in McClures

McClure-Phillips Company, New York City

Buffalo Outline in Display

Body Type set in 10-Point Viking

THE H. C. HANSEN TYPE FOUNDRY

Lining De Vinne No. 3

Standard Line

48-Point

4A 5a \$7.75

Caps \$4.60 l.c. \$3.15

MODERN LETTER

Used for Programs

Books

Three Special Bargains

Tennyson's Poems, elegantly bound volumes, never before sold for less than \$2.50 a volume, now going at **\$1.75**

History of the World, in three volumes, a complete and concise history, with many valuable references **\$2.98**

Quo Vadis, a marvellous book, only twenty copies left. This book has been read by over twenty thousand **\$1.15**

Bacon & Smythe

134 Hunnewell Street, Holyoke, Mass.

6-Point 22A 44a \$2.00 Caps \$0.95 l.c. \$1.05

AMAZING RESULTS OBTAINED WITH THIS SERIES De Vinne types have proven their worth. No job office can be considered complete without a series of this type, and it is a standard display face in nearly every news office in the country. Finely proportioned letters with pleasing lines combine to carry strength and beauty 8

8-Point 21A 43a \$2.25 Caps \$1.00 l.c. \$1.25

ARTISTIC SHOWING, MUSLIN DRAPERIES and lace curtains in great variety, also large and varied assortment of parlor tables, in all the fancy colorings, may be seen at Wright's department store, the largest store of 3560

10-Point 20A 40a \$2.50 Caps \$1.15 l.c. \$1.35

THE CHARACTERISTIC ENTERPRISE of American people is shown in many ways. Railway and steamship lines to all parts of the inhabited globe 12478

12-Point 16A 30a \$2.75 Caps \$1.30 l.c. \$1.45

METAL QUOTATIONS CAST in Steel Moulds on a Machine which also casts Type, thereby ensuring accuracy to points 12

36-Point

4A 7a \$5.25

Caps \$2.65 l.c. \$2.60

EXTRA EDITION ISSUED

By the Evening Reporter 2

When ordering to match type in case, send Cap "H" and l.c. "m"

THE H. C. HANSEN TYPE FOUNDRY



Lining De Vinne No. 3

Standard Line

60-Point

3A 4a \$9.25

Caps \$5.60 l.c. \$3.65

OLDS Mobile 5

30-Point

5A 9a \$4.25

Caps \$2.10 l.c. \$2.15

EXTREMELY POPULAR FACES The De Vinne Type Always in Use

24-Point

6A 11a \$3.50

Caps \$1.65 l.c. \$1.85

FAST RACING BEHIND THE MOTORS Maidens Admitted With Chaperons 234

18-Point

9A 18a \$3.25

Caps \$1.50 l.c. \$1.75

BARGAINS TO ALL PURCHASERS AT THE STORE Of Messrs. Soaks & Company, Bingville, Pennsylvania Goods retailed at 309 cents on the dollar. Come early

14-Point

14A 24a \$3.00

Caps \$1.45 l.c. \$1.55

A CATCHY ADVERTISING DEVICE, HANDSOMELY DESIGNED and well printed will carry conviction to the readers and an increase of trade is bound to result; therefore use printers' ink liberally 24

42-Point

4A 6a \$6.45

Caps \$3.45 l.c. \$3.00

THE BEST READING Is Found in Libraries 7

When ordering to match type in case, send Cap "H" and l.c. "m"

THE H. C. HANSEN TYPE FOUNDRY

Lining De Vinne Condensed No. 3

Standard Line

48-Point

3A 6a \$6.25

Caps \$3.15 l.c. \$3.10

ORIGINAL Rule Design 7

42-Point

4A 7a \$5.40

Caps \$2.70 l.c. \$2.70

Money out on INTEREST \$5

36-Point

4A 8a \$4.25

Caps \$2.05 l.c. \$2.20

REMARKABLE Group of Men 23

30-Point

6A 11a \$4.00

Caps \$1.90 l.c. \$2.10

**PRINTING TYPES
Made by Hansen 8**

24-Point

8A \$14a 3.50

Caps \$1.70 l.c. \$1.80

**SPECIAL REPORTERS
Detailed for night work**

18-Point

12A 24a \$3.25

Caps \$1.50 l.c. \$1.75

**CLEVER SCARE HEADLINES
When an exclusive news item
is secured it is given the top**

14-Point

16A 30a \$3.00

Caps \$1.50 l.c. \$1.50

**AN ACCURATE COMPOSING STICK
Is by all means the only one to buy.
This is also true of any other kind
of Printers' Tools. Buy the best 38**

12-Point

21A 40a \$2.75

Caps \$1.25 l.c. \$1.50

**HARD AND EXTRA TOUGH METAL USED
In the manufacture of all Type made by The
Hansen Type Foundry, Boston, Mass. 123456**

10-Point

25A 50a \$2.50

Caps \$1.15 l.c. \$1.35

**INK AND ROLLER CABINETS NECESSARY ARTICLES
A place for everything and everything in its place is a
good maxim for printers to follow. By keeping rollers
and ink in cabinets specially designed for them saves 5**

8-Point

28A 52a \$2.25

Caps \$1.05 l.c. \$1.20

**INTELLIGENCE AND INDUSTRY ARE ESSENTIAL FACTORS
In the rapid development of any business there is always good
and sufficient reason for the deserved success it has attained**

6-Point

28A 58a \$2.00

Caps \$0.90 l.c. \$1.10

**A REPUTATION FOR PROMPTNESS IS ONE OF THE NECESSARY THINGS
that a job printer should strive for. He will have gained a great advantage
when it comes to be said of him that he always gets work out on time, and
it will pay him to endeavor to secure such a reputation by every means 24**

When ordering to match type in case, send Cap "H" and l.c. "m"

THE H. C. HANSEN TYPE FOUNDRY

Lining De Vinne Italic No. 3*Standard Line*

48-Point

3A 6a \$7.75

Caps \$3.90 l.c. \$3.85

ROUND Corners 12

42-Point

4A 6a \$6.55

Caps \$3.35 l.c. \$3.20

Song of the VIOLET 8

36-Point

4A 7a \$5.00

Caps \$2.50 l.c. \$2.50

RELIABLE Type and Rule

30-Point

5A 8a \$4.25

Caps \$2.25 l.c. \$2.00

**TRUTH READ
Great Thought**

24-Point

6A 10a \$3.50

Caps \$1.80 l.c. \$1.70

**STOP CYLINDER
Prints Halftones 6**

18-Point

9A 18a \$3.25

Caps \$1.45 l.c. \$1.80

**NOTE THE GRACEFUL
Lines of De Vinne Italic
It is always a favorite 62**

14-Point

12A 21a \$3.00

Caps \$1.50 l.c. \$1.50

**PERFORATING MACHINES
Built very strong and durable
having advantages over other
machines of similar nature 7**

12-Point

14A 28a \$2.75

Caps \$1.25 l.c. \$1.50

**MODERN TYPOGRAPHIC EFFECT
Attained by constant study and hard
work, is a great source of pride 35**

10-Point

20A 38a \$2.50

Caps \$1.20 l.c. \$1.30

**TYPE, BORDERS, ORNAMENTS AND RULE
All made by the H. C. Hansen Type Foundry
under one roof. This is a decided advantage
to printers who have many rush orders 378**

8-Point

18A 36a \$2.25

Caps \$1.10 l.c. \$1.15

**AUTOMOBILES ALONG THE STATE HIGHWAYS
Among the sports of the good old summer time there
are probably none which ranks with automobiling 24**

6-Point

24A 46a \$2.00

Caps \$0.95 l.c. \$1.05

**A REPUTATION FOR PROMPTNESS IS ALWAYS NECESSARY
If your office is run systematically, you can tell after a moment's
reflection just how the work is getting along, and what chances
there are for getting a new job started in. Then you know 456**

When ordering to match type in case, send Cap "H" and l.c. "m"

THE H. C. HANSEN TYPE FOUNDRY

LINING DE VINNE EXTENDED

Standard Line

30-Point

4A 6a \$4.55

Caps \$2.45 l.c. \$2.10

MAGNIFICENT ROADS Along the Boulevards 24

6-Point

16A 32a \$2.00

Caps \$0.85 l.c. \$1.15

WHEN YOU ARE ALL READY TO SET TYPE you will first have to set your stick to a given measure. Be very careful about this and do not guess at the measure; neither use leads nor slugs, but always twelve-point quads. The stick should be closed upon these quads to make them as tight as you will space your matter later on. As you know, every letter has a nick, which must be placed in your stick, facing outward. There is a special nick by which you can distinguish Hansen's type from any other, it is called the diamond nick. Type with this nick is reliable and 273

8-Point

13A 26a \$2.25

Caps \$1.00 l.c. \$1.25

IN DISTRIBUTING DISPLAY LINES great care should be exercised. Be sure you have the right case, both as to size and face of type to be distributed. If you should distribute a ten-point size in a twelve-point case you are not only wasting your own time but also that of others as well who should be so unfortunate as to find type in cases where it does not

10-Point

13A 26a \$2.50

Caps \$1.15 l.c. \$1.35

BRASS RULE IS VERY USEFUL but if it is not cut to labor-saving sizes it is a source of great loss of both time and money. After you have ascertained the length of rule you need, set your stick to the size required, cut your rule of equal length at one time, about four points longer than the size required. This allows enough 13

12-Point

10A 20a \$2.75

Caps \$1.35 l.c. \$1.40

ARTISTIC COMPOSITORS are always striving to get out of the rut, or to speak more plainly, to produce work that is far above the average; to harmoniously assemble type, borders, ornaments and brass rule

14-Point

9A 16a \$3.00

Caps \$1.50 l.c. \$1.50

HUSTLING AROUND and trying to set a job up in the quickest time possible, compositors are often handicapped by the limited amount of leads, quads, etc. 48

18-Point

7A 12a \$3.25

Caps \$1.60 l.c. \$1.65

UNREASONABLE as it may seem to have a friend enter your printing office and demand his job before the type is 9

24-Point

5A 8a \$3.65

Caps \$1.95 l.c. \$1.70

LONG LINES SET QUICKLY With De Vinne Extended 236

THE H. C. HANSEN TYPE FOUNDRY



LINING DE VINNE EXTENDED

Standard Line

42-Point

3A 4a \$6.80

Caps \$4.05 l.c. \$2.75

STRONG LINES Produce Results

GREAT BARGAINS!

Just to give an impetus to trade we are offering some phenomenally low values in our boot and shoe department. These are not shop-worn goods, but are all right in every way. As a leader we offer

OXFORDS

AT **\$2.98** PAIR

The hot summer days will soon be here. Be prepared to keep your feet nice and cool and make a saving in your purchase besides.

Bootem, Shoem & Company

25 Lowcut St., Delaware, Md.

Rule No. 12 530 60 cts. ft. Body letter is Hansen's 10-point Caslon Old Style No. 2

48-Point

3A 4a \$9.35

Caps \$5.70 l.c. \$3.65

USEFUL Type

36-Point

3A 4a \$5.20

Caps \$3.15 l.c. \$2.05

POSTER EXHIBIT Mechanics Pavilion

THE H. C. HANSEN TYPE FOUNDRY

LINING DE VINNE EXTRA CONDENSED No. 3

Standard Line

72-Point

3A \$4.10 6a \$4.65 \$8.75

USEFUL TYPE SERIES

Finely Graded Sizes 134

12-Point

25A \$1.20 50a \$1.55 \$2.75

THE NUMBER AND VARIETY OF SIGNS USED IN PRINTING ARE MUCH GREATER THAN THE CASUAL OBSERVER WOULD Expect. Besides those used in ordinary work there are many which are only needed in special cases. But a compositor needs to know them all, not only their names but also their uses. And yet how few have ever cared to study them or even make themselves acquainted with their names. A great many men are puzzled when they come across medicinal, astronomical or algebraical sign in their copy, and not

14-Point

22A \$1.40 40a \$1.60 \$3.00

THE NUMBER AND VARIETY OF SIGNS USED IN PRINTING ARE MUCH GREATER THAN CASUAL Observer would expect. Besides those used in ordinary work there are many which are only needed in special cases. But a compositor needs to know them all, not only their names but also their uses. And yet how few have ever cared to study them or even make themselves acquainted with their

**IMPORTED FRANCONIAN
AUTOMOBILE**

The new models of these world famous machines have arrived and ready for inspection. We give away with every sale a full grown good looking Chauffeur, warranted to be free from bad habits and guaranteed kind and gentle. Call for catalog

LAFAYETE COMPANY
GARAGE CHAMBERS

60-Point

4A \$3.50 6a \$3.50 \$7.00

RAILROAD TRANSPORTS

Established Quick Service

THE H. C. HANSEN TYPE FOUNDRY

LINING DE VINNE EXTRA CONDENSED No. 3

Standard Line

48-Point

5A \$2.90 9a \$3.35 \$6.25

ORIENTAL RUGS, EMBROIDERIES And Fancy Perfumes at low price

30-Point

9A \$1.80 16a \$2.20 \$4.00

THE NUMBER AND VARIETY OF SIGNS USED BY THE
Printer are very much greater than the casual observer

18-Point

16A \$1.45 31a \$1.80 \$3.25

24-Point

11A \$1.65 20a \$1.85 \$3.50

THE NUMBER AND VARIETY OF SIGNS IN
PRINTING ARE MUCH GREATER THAN THE
Casual observer would expect. Besides
those used in ordinary work there are
many which are only needed in special
cases. A compositor needs to know them
all, not only their names but also their
uses. And yet how few have ever cared

THE NUMBER AND VARIETY OF
SIGNS USED IN PRINTING ARE
Much greater than the casual ob-
server would imagine. Besides
those used in ordinary work there
are many which are only needed

36-Point

6A \$2.05 10a \$2.20 \$4.25

THE NUMBER AND VARIETY OF SIGNS USED
In Printing are very much greater than \$2.83

42-Point

5A \$2.40 10a \$2.95 \$5.35

BEAUTIFUL DISPLAY OF IRON WORK
By American and European Artists. 90

THE H. C. HANSEN TYPE FOUNDRY

LINING HANSEN OLD STYLE No. 30

Standard Line

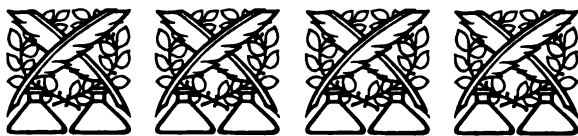

Berkshire Ornament No. 36. 25 cents each

IN these days of advanced ideas, advertising is one of the most profitable vocations connected with the printing business. The man who is anxious to stimulate public interest in his wares is usually on the lookout for a printer who has the happy faculty of expressing things in an interesting manner, and, having said it, is able to print it in the most attractive style. How does he know this printer? Chiefly by the "proof of the pudding." If a printer sets forth the quality of his wares in an uninteresting way, with hackneyed and carelessly worded literature, how can he ever hope to arouse any interest among an up-to-date patronage? This question of properly advertising a printing business is of great moment, and it is true that the popularity of the most successful printers can be traced to the one great fountain head—originality. The small job printer or the large concern who would acquire fame, must have original ideas.

10-Point

20A \$1.30 38a \$1.20 \$2.50

6-Point 25A \$1.00 50a \$1.00 \$2.00

TRY AND DO A LITTLE MORE WORK THAN YOU ARE PAID FOR

It is perfectly amazing how blind to their own interests are the workers in shop, office and factory. To do a little more than you are paid for, to look after your employer's interests and thus save him material or time, these aberrations of mind upon the part of some ambitious employee are the cause of criticism and ridicule from fellow employees. Then, when the busy, earnest, ambitious employee is promoted, it is said to be a case of "favoritism." We have seen a foreman of a printing office sneak into a corner and read the paper when the employer was absent. We have seen him fool away time when work was rushing, just to show the employees under him that he didn't have to hurry. We have seen the same man madder than a hornet when his request for a "raise" was met with a refusal. So it goes. Employees throw away their own chances of winning advancement and the favor of their employers, and then complain of the treatment they receive from this cold, cruel world. ❀ ❀ ❀ ❀

8-Point 22A \$1.25 44a \$1.00 \$2.25

A LITTLE TREATISE ON USING THE HYPHEN

For some occult reason, aversion to the use of the hyphen is very common. Certainly some people do say that frequent hyphens spoil the appearance of print, but many others find nothing worse-looking in them than any other character or mark. Very likely the underlying fact is that the use of hyphens is thought to be too troublesome. Whatever may be the preference of any one, undoubtedly all practical printers will say that it is comfortable and economical to have in the printing office a practice that all the workers can apply with like effect, and this is nearly all that is possible of attainment. Even so, much can be done only in one way, namely that of having at hand a record of all forms chosen for use. ❀ ❀ ❀ ❀ ❀ ❀

12-Point

17A \$1.45 34a \$1.30 \$2.75

PRODUCTS OF THE H. C. HANSEN TYPE FOUNDRY ARE SOUGHT

By the printers who desire to increase their business by the addition of new labor-saving devices, combined with type faces, borders and ornaments par excellence and metal furniture

14-Point

13A \$1.60 26a \$1.40 \$3.00

SPECIAL COMPOSING ROOM EQUIPMENTS DESIGNED 2345

Anything needed for the composing room, which is not carried in stock, will be made to order very quickly. Cabinets of special size and design ❀ ❀ ❀

When ordering to match type in case, send Cap "H" and l.c. "m"

THE H. C. HANSEN TYPE FOUNDRY



LINING HANSEN OLD STYLE No. 30

Standard Line

48-Point

4A \$3.95 9a \$3.70 \$7.65

STUDY PHILOSOPHY
Act quickly  Aim high 8

42-Point

4A \$3.25 9a \$3.00 \$6.25

AROUND THE TRACK
Buzzing Automobiles Fly  5

36-Point

5A \$2.80 9a \$2.20 \$5.00

QUIET SPOT
In the Summer

30-Point

6A \$2.40 10a \$1.90 \$4.30

FISHING RODS
Catch Shiny Trout

24-Point

7A \$2.00 13a \$1.50 \$3.50

DOUBLE NUMBER
Of the Metropolitan 

18-Point

11A \$1.65 22a \$1.60 \$3.25

HANSEN OLD STYLE 
A good letter for commercial
and high art booklet printing

When ordering to match type in case, send Cap "H" and l.c. "m"

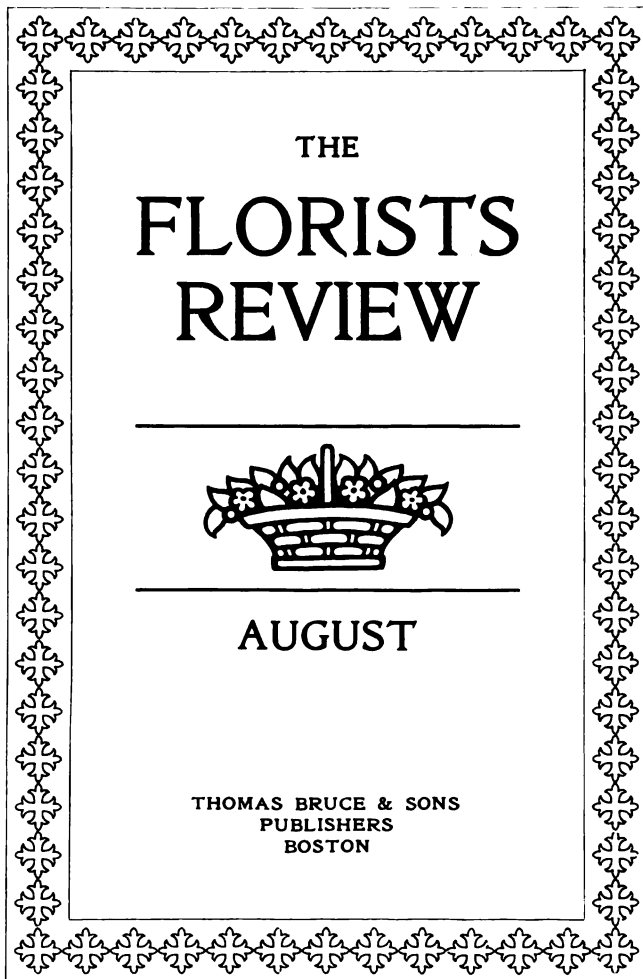

18-Pt. Croix Border No. 314, 36 inches \$1.30

THE H. C. HANSEN TYPE FOUNDRY

Lining Hansen Old Style Italic No. 30

NEW ITALIC FACE

24-Point

7A \$1.95 12a \$1.55 \$3.50

This is the companion face to the type shown on pages 92-93. It is cast on Standard Line, Point Body and Unit Set Specimen sheets of the complete series from 6 to 48 point are in preparation and will be sent to all interested parties

HIGH ART BRASS RULE NO. 12 860. PER FOOT, \$0.75

THE RULES ON THIS PAGE SHOW TWO OF OUR NEW HALF TONE RULES. MADE OF SOLID BRASS THEY PRESENT A WEARING SURFACE FAR MORE DURABLE THAN PLATES. ORIGINATED BY THE H. C. HANSEN TYPE FOUNDRY. SEE PAGE 228. PRINTED DIRECT FROM RULES. CORNERS ARE NOT SOLDERED

HIGH ART BRASS RULE NO. 6 857. PER FOOT, \$0.40

THE H. C. HANSEN TYPE FOUNDRY



*THE HANSEN
OLD STYLE
ITALIC No. 30*

ESTABLISHED 1872

*THE H. C. HANSEN TYPE
FOUNDRY* 190-192 CONGRESS ST., BOSTON
535 PEARL ST., NEW YORK

Hansen Old Style Italic No. 30

STANDARD LINE

6-Point 26A \$1.00 52a \$1.00 \$2.00

THE EQUIPMENT OR "PLANT" OF A TYPE FOUNDRY CONSISTS OF hundreds of thousands of moulds, machines, tools and appliances. Because of great accuracy required in the products, it takes a long time, great skill and large capital to equip the plant, as only ordinary machinery and tools can be purchased, all those required for the finer work having to be designed and made especially for their various purposes. \$12345678

8-Point 23A \$1.10 46a \$1.15 \$2.25

PRODUCING THE EQUIPMENT FOR A SUCCESSFUL Type Foundry has, invariably, been accomplished only by ardent and high skilled work, and, almost invariably, only through succeeding skill of several generations, and through various stages and changes of ownership have they reached the stage where they can be called successful and first-class

10-Point 20A \$1.25 40a \$1.25 \$2.50

THE H. C. HANSEN TYPE FOUNDRY HAS The distinction of being the only Type Foundry in this country to become successful and first-class through the persistent labor and skill of one person, unaided by combinations, and in face of exceedingly sharp competition. An Independent Type Foundry

**Hansen Old Style
Italic No. 30**

An attractive italic type series which we produce in response to a constant demand for an italic face to use in conjunction with the popular Hansen Old Style No. 30. Pages 92-93 of our catalog

A Very Useful Series

The Order of Dances

✻

- 1 *Waltz*

- 2 *Two-Step*

- 3 *Schottische*

- 4 *Portland Fancy*

- 5 *Waltz*

- 6 *Two-Step*

- 7 *Waltz*

- 8 *Lancers*

- 9 *Two-Step*

- 10 *Waltz*

INTERMISSION

8-PT. ROYAL BORDER, 60 INS. \$1.80

12-Point 16A \$1.30 36a \$1.45 \$2.75

TYPE FOUNDRY ART IS THE BASIS Of the art of typography, which, in turn is very essential to the growth and expansion of every other line of industry. The history of European type foundries clearly demonstrates the above

18-Point 11A \$1.70 20a \$1.55 \$3.25

NOT A PASSING FAD BUT A dividend paying type face that is of practical use 52 weeks per year in any live office in city or country

THE H. C. HANSEN TYPE FOUNDRY

Hansen Old Style Italic No. 30

STANDARD LINE

36-Point

4A \$2.70 9a \$2.30 \$5.00

*THE PROMPT AND RELIABLE
Printers kept busy at all seasons 52*

24-Point

7A \$1.95 12a \$1.55 \$3.50

*PROPER EQUIPMENT
Fonts of generous size are
an economy, saving waste
of time in sort hunting 35*

30-Point

6A \$2.30 10a \$1.95 \$4.25

*WHAT YOU PAY
For type is investment
What you pay for the
merry sort hunt is loss*



48-Point

3A \$4.60 6a \$3.15 \$7.75

*MACHINES IN STOCK
Print-shop Equipment Here*

THE H. C. HANSEN TYPE FOUNDRY



FRED B. ROYAL takes pleasure in announcing that he has purchased the plant and good will of Wellington & Martin, which will now be conducted as

The Royal Press

The office will be equipped throughout with Hansen Superior Quality Products which, with a thorough knowledge of the business and the employment of only expert workmen, will insure quality and accuracy of production that will satisfy the requirements of the most exacting.

May we do Your Printing?

EDUCATOR SQUARES

Hansen
Old Style
Italic

No. 30



Standard
Line

REGISTERED TRADE MARK



Far Above
Others

Is the Superior Quality of Type, Borders, Brass Rule, Cast and Electrotyped Ornaments made by the Hansen Foundry

The Quality

above referred to, is obtained by use of specially constructed machinery operated by experienced workmen. The metal used in Hansen Type is best for durability and fine printing quality.

The H. C. Hansen
Type Foundry

Established 1872

Boston and New York

MISS RHODA WILSON

MISS FRANCES BRIGHAM

A JOINT RECITAL
OF PIANO AND VOCAL MUSIC
AT HARMONY HALL AT EIGHT O'CLOCK
ON THE EVENING OF THURSDAY
SEPTEMBER THE NINTH

SYMPHONY OPEN 134, 150

TICKETS, 35 CENTS

This Paper is a sample of Wheelwright's Best Plate Finish 25 x 38—90

LINING LATIN CONDENSED No. 3

Standard Line

48-Point

6A \$3.25 10a \$3.00 \$6.25

HERE WE SERVE YOU THE BEST 25 Printing Types, Borders and Ornaments

10-Point

30A \$1.25 50a \$1.25 \$2.50

WHO EVER KNEW OF A COUNTRY PRINTING OFFICE THAT WAS Not haunted by some quaint urchin eager to learn the mysteries of the case? Sometimes he is awkward and uncouth. Oftentimes he is barefooted. Occasionally he has a freckled face and red hair. Again he develops a peculiar reticence that betokens restlessness and ambition. You will find him picking type from the sweepings of the office while on his way to school. You will see him forcing an imprint from the type upon the blank pages of his school books. The country editor is, in his eyes, a greater man than the rural parson. The boy has longing looks as he gazes at the office. It is indicative of the one desire of his heart, that of presiding over the hell-box and reaching the mighty and exalted

12-Point

26A \$1.40 44a \$1.35 \$2.75

WHO EVER KNEW OF A COUNTRY PRINTING OFFICE THAT Was not haunted by some quaint urchin eager to learn the mysteries of the case? Sometimes he is awkward and uncouth. Oftentimes he is barefooted. Occasionally he has a freckled face and red hair. Again he develops a peculiar reticence that betokens restlessness and ambition. You will find him picking type from the sweepings of the office while on his way to school. You will see him forcing an imprint from the type upon the blank pages of his school books. The country editor is, in his eyes, a greater man

18-Point

18A \$1.60 32a \$1.65 \$3.25

WHO EVER KNEW OF A COUNTRY PRINT-Ing office that was not haunted by some quaint urchin eager to learn the mysteries of the case? Sometimes he is awkward. Oftentimes he is barefooted. Occasionally he has a freckled face and red hair. Again he develops a peculiar reticence that be-tokens restlessness and ambition. You will

24-Point

12A \$1.80 20a \$1.70 \$3.50

WHO EVER KNEW A COUNTRY Printing office that was not haunt-ed by some quaint urchin eager to learn the mysteries of the case? Sometimes he is awkward and un-couth. Oftentimes he is \$26.30

36-Point

6A \$2.05 12a \$2.20 \$4.25

LATIN COND. FOR FINE LABEL PRINTING 4

Found in an office well planned with judgment

When ordering to match type in case, send Cap "H" and l.c. "m"

THE H. C. HANSEN TYPE FOUNDRY

Antique No. 31

36-Point

3A \$2.50 6a \$2.50 \$5.00

WORTHY MATRONS

Perform acts of charity

8-Point

18A \$1.00 36a \$1.25 \$2.25

THERE ARE CERTAIN CASES WHERE Exact bids must be submitted. It is not always the lowest bid that gets the order. In placing an order for printing, a business man seldom binds himself to accept the lowest bid and he will be influenced by many considerations besides mere price. He knows that the lowest bid often indicates inferior goods or poor service. 35

10-Point

15A \$1.20 30a \$1.30 \$2.50

ACCORDING TO TURKISH LAW All printing establishments may each have only one door, and that opening to the street. Windows must all be covered with close-meshed wire netting, so that no papers can be handed through.

12-Point

15A \$1.25 30a \$1.50 \$2.75

NEWSPAPER PUBLICATION AND JOB DEPARTMENTS Are more closely allied in smaller towns. There are many instances where this is absolutely necessary. The force on

12-Point Buffalo Outline Border No. 3. 54 inches, \$1.50

18-Point

7A \$1.50 15a \$1.75 \$3.25

DAVENPORT CAMERA CLUB'S EXHIBIT

Souvenirs of pleasant days in Oneida, Maine

24-Point

5A \$1.65 10a \$1.85 \$3.50

SPHINX OF ANCIENT EGYPT

Famous pyramid built by Cheops

48-Point

3A \$4.50 4a \$3.00 \$7.50

BRAINSTORMS

Great arguments

THE H. C. HANSEN TYPE FOUNDRY

LINING HANSEN OLD STYLE No. 40

STANDARD LINE

18-Point

10A \$1.85 20a \$1.40 \$3.25

PRINTING KNOWN IN CHINA IN SIXTH CENTURY

Modern devices for elimination of superfluous labor then unknown

6-Point

25A \$1.00 50a \$1.00 \$2.00

THE GREAT DURATION OF WOOD WHEN KEPT VERY DRY
Beams still exist which are known to be over eleven hundred years old. Piles driven by the Romans prior to the Christian era have been examined of late, and found to be perfectly sound after an immersion of nearly two thousand years. The wood of some tools will last longer than the metals, as in spades, hoes and plows. In other tools the wood is first gone, as in wagons, wheelbarrows and machines. Such wood should be painted or oiled; the paint not only looks well

8-Point

22A \$1.25 44a \$1.00 \$2.25

PLANETS ALIKE IN BROAD GENERAL FEATURES
The ball or globe-like form is peculiar to all of them, they are all dark bodies, deriving light and heat from the sun, and consequently they all reflect the same borrowed light. In common, they all perform two motions, one a spinning or rotary motion on an axis, the other a motion of translation, which whirls them

10 Point

20A \$1.30 38a \$1.20 \$2.50

PLUCK WINS! IT ALWAYS WINS, THOUGH
Days be slow and nights be dark 'twixt days that come and go. Still pluck will win—Its average is sure—He gains the prize who can the most endure; who faces issues, he who never shirks, who waits

12-Point

17A \$1.45 34a \$1.30 \$2.75

SINCE THE DAYS OF GUTENBERG
The use of printing has increased rapidly until today it has become a necessity in the world of business. It is the media through which the news of the day is transmitted to the 456

24-Point

7A \$2.00 13a \$1.50 \$3.50

PRODUCT OF THE HOUSE OF HANSEN

Is most satisfactory and is noted for superior quality

36-Point

5A \$2.80 9a \$2.20 \$5.00

PLEASE YOUR CUSTOMERS

Large return from small investment

Sold in weight fonts of 25 lbs. and multiples

THE H. C. HANSEN TYPE FOUNDRY

97

CANDLE LIGHT
THE MOST PROMISING COPPER
MINE IN THE RICHEST MINING
DISTRICT OF SOUTHERN UTAH

PROSPECTUS



ALWIN, WILSON & McDUFFY CO.
Fiscal Agents
CONTINENTAL BUILDING, NEW YORK

8-Pt. Swastika Outline Border No. 4. 54 inches, \$1.35

Curvive Script

18-Point 5A \$1.10 20a \$1.50 \$2.60

*Fifth Annual Exhibition
of imported
Japanese Water Color Paintings
and Tapestries
March 28 to April 3, 1908
The Rothemore Studio
Birmingham*

Black Text

10-Point 16A \$1.30 40a \$1.50 \$2.80

There is no more honorable calling than that of the printer. He is the conservator of the world's learning. He is responsible for the preservation and the passing down from the one generation to another of the accumulated knowledge and wisdom of the ages. Education, entertainment, culture and commerce rest upon the shoulders of the printer. He should be a prince among men. But to occupy the position that he should, he must "put money in his purse." This he can not do if he does not ask and get for his work what it is worth.

Lining Boldface No. 150

(Standard Newspaper Letter)

Standard Line

*5½-Point 20A \$0.90 40a \$1.10 \$2.00

A REPUTATION FOR PROMPTNESS

It is one of the things that a job printer should strive for. He will have gained a great advantage when it comes to be said of him that he always gets work out on time 12
*Special Line

6-Point 22A \$0.90 44a \$1.10 \$2.00

ALL TYPE DISPLAYED BY H. C. HANSEN

is made in this Type Foundry, and made under one roof. All type faces shown in this Specimen Book are made by H. C. HANSEN. Thousands of special rules are made to order. Rule sold in two-foot strips. All orders receive prompt and careful attention. No order too large, and

8-Point 17A \$1.05 35a \$1.20 \$2.25

ANCIENTS AND HONORABLES

Coming to visit Boston and friends in June
An elegant parade and sumptuous banquet
in the Cadet Armory, Boston.

10-Point 16A \$1.15 32a \$1.35 \$2.50

EIGHT NEW BATTLESHIPS

To be the most powerful in the world
United States Navy increasing
Protecting Commerce and Harbors

When ordering to match type in case, send Cap "H" and Lc. "m"

7-Point 22A \$1.05 44a \$1.20 \$2.25

SPECIAL HANDY BRACES (METAL)

Hansen's Handy Braces are made to save time and do away with piece braces, thus doing the work quickly and with better satisfaction for the printers that have to use a number of braces
A GREAT LABOR-SAVER

9-Point 20A \$1.15 40a \$1.35 \$2.50

**THE BOARD OF TRADE MEETING
held at the Comma Building**

The "Waste Basket" furnished the Board
with amusement for the ensuing year 1903
NEXT MEETING FOR ARCHITECTS

12-Point 13A \$1.25 26a \$1.50 \$2.75

LATEST FOREIGN NEWS

The Philippines under the
U. S. Government
Complete control accepted

Sold in weight fonts of 25 lbs. and multiples

THE H. C. HANSEN TYPE FOUNDRY

Boldface No. 16

36-Point

3A 5a \$6.50

Caps \$3.25 l.c. \$3.25

RACES BEGUN
on the Hour 12

24-Point

4A 7a \$4.40

Caps \$2.20 l.c. \$2.20

PRINTERS USE
Hansen's Type 3

18-Point

5A 10a \$3.25

Caps \$1.50 l.c. \$1.75

METAL FURNITURE CAST
Accurately to Point System
as well as Leads and Slugs

12-Point

8A 16a \$2.75

Caps \$1.30 l.c. \$1.45

USEFUL EXTENDED FACES 8
Are constantly in great demand
for Setting Long Lines Quickly

10-Point

9A 18a \$2.50

Caps \$1.10 l.c. \$1.40

DOUBLE COLUMN ADVERTISEMENTS INSERTED
in Newspapers and Magazines at Current Rates \$2
Our Experts Will do Your Ad.-Writing Free Gratis

8-Point

10A 22a \$2.25

Caps \$1.00 l.c. \$1.25

ORNAMENTATION IN TITLE PAGES OF ART
Depends wholly on the character of the book
and compositors should exercise judgment 5

6-Point

12A 22a \$2.00

Caps \$0.90 l.c. \$1.10

SYSTEMS WHICH PROVIDE MUTUAL EXCHANGE OF COMMODITIES
are manifestly essential to the continued and healthful growth
of our export trade. We cannot expect that we can forever sell 6

THE H. C. HANSEN TYPE FOUNDRY



HEADING SERIES

POINT LINE

18-Point

12A \$1.35 24a \$1.90 \$3.25

THE STERLING ROUND CORNERING CUTTER, REASONABLE IN PRICE AND RAPID
Designed to meet the requirements of Printers and Bookbinders. Price \$15.00

24-Point

9A \$1.40 18a \$2.10 \$3.50

36-Point

5A \$2.10 9a \$2.15 \$4.25

THE FULL ADVANTAGE THAT
Will be realized from using
time slips is not secured if
they are simply utilized for

GREAT ADVANTAGE
All material used by
printers made on the

42-Point

4A \$2.40 7a \$2.85 \$5.25

BRASS RULES, Borders and 23.98



HEADING OUTLINE

POINT LINE

18-Point

12A \$1.35 24a \$1.90 \$3.25

THE STERLING ROUND CORNERING CUTTER, REASONABLE IN PRICE AND RAPID
Designed to meet the requirements of Printers and Bookbinders. Price \$15.00

24-Point

9A \$1.40 18a \$2.10 \$3.50

36-Point

5A \$2.10 9a \$2.15 \$4.25

THE FULL ADVANTAGE THAT
Will be realized from using
time slips is not secured if
they are simply utilized for

GREAT ADVANTAGE
All material used by
printers made on the

42-Point

4A \$2.40 7a \$2.85 \$5.25

BRASS RULES, Borders and 23.98

THE H. C. HANSEN TYPE FOUNDRY



LINING LATIN ANTIQUE No. 3

Standard Line

48-Point

3A \$4.40 5a \$3.10 \$7.50

SEND FIFTY \$50 For Public Needs

36-Point

3A \$2.50 6a \$2.50 \$5.00

WISE MEN Determine

30-Point

4A \$1.90 9a \$2.35 \$4.25

PRINTING TYPE At Hansen's

24-Point

5A \$1.50 12a \$2.00 \$3.50

THE VERY BEST 7 Quick Shipment

18-Point

8A \$1.50 18a \$1.75 \$3.25

LARGE ORDERS DELIVER Direct from Boston or New York

*12-Point

14A \$1.25 30a \$1.50 \$2.75

GOOD OLD LATIN ANTIQUE Never Out of Style 123

8-Point

16A \$1.00 35a \$1.25 \$2.25

MAY BE RELIED UPON IN EVERY CASE Plain letter, clean cut, easily read

When ordering to match type in case, send Cap "H" and l.c. "m"

10-Point

15A \$1.10 30a \$1.40 \$2.50

EXHIBIT OF PRINTED MATTER Containing process work 3

6-Point

18A \$0.90 37a \$1.10 \$2.00

SOMETHING NEW IN TYPE AND ORNAMENTS Is constantly emanating from Hansen's

*On Point Line; too large for Standard Line

The
Sterling
Round Cornering
Machine



Booklet
for the
Asking

In Stock and For Sale by
The H. C. Hansen
Type Foundry
Boston, Mass.

THE H. C. HANSEN TYPE FOUNDRY

Lining Modern Antique No. 3

18-Point

Standard Line

10A \$1.45 22a \$1.80 \$3.25

WHEN A MAN STARTS OUT IN BUSINESS HIS ADVERTISING Starts with him. If a man so advertise himself as to create a prejudice against his work it were better had he never begun

6-Point

20A \$0.90 40a \$1.10 \$2.00

8-Point

18A \$1.00 36a \$1.25 \$2.25

THE GOLDEN GLOW HAS FADED, THE FIRE OF AUTUMN FLED, AND WINTER, DARKLY SHADED, IS ROUND US NOW INSTEAD. But where hearthfires burn brightest, where happy voices flow, where love is ever present, ne'er fades the golden glow. 1234567 How dear to our hearts is the old silver dollar, when some kind subscriber presents it to view—The liberty head without necktie

NO SANE MAN TODAY DOUBTS THE INFLUENCE OF THE JOURNALIST, AND NONE BUT POLITICIANS OR Fools belittle it. The voice of the minister, orator and politician dies out in faint echoes from a very narrow horizon, unless it is reverberated by the 12

BLACKSTONE VALLEY POULTRY YARDS

A 30 DAY SPECIAL OFFER

Offer for sale a limited number of well-built, able-bodied



Handsome Game Cockerels

The ancestors of these birds are prize winners and have moved in the most aristocratic poultry circles for many generations. These cockerels have inherited the sporting instincts of their sires and will furnish much excitement

Price, each, \$24.98

FREE! FREE! FREE!

With each bird sold in the next 30 days we will give free, a beautiful hand illumined certificate giving its full pedigree together with its photograph done in genuine sepia by Gustafson & Vincent, the celebrated Metropolitan photograffers

**Address BLACKSTONE VALLEY POULTRY YARDS
MIANTONOMI ROAD, SKOWHEGAN CENTRE, NEW HAMPSHIRE**

6-Point Border No. 502. 60 inches, \$1.50

10-Point

17A \$1.05 34a \$1.45 \$2.50

12-Point

15A \$1.20 32a \$1.55 \$2.75

WHAT THE LEAVES ARE TO THE FOREST, WITH LIGHT AND AIR FOR FOOD, ERE THEIR SWEET And tender juices become hardened into wood,— That to the world are children; through them it feels the glow of a brighter and sunnier 178

CERTAIN PHENOMENA IN THE AIR AND PECULIARITIES OF THE BIRDS Have long been known to indicate a change in the weather. Many years

24-Point

7A \$1.70 12a \$1.80 \$3.50

JUSTICE IN THE WORKSHOP IS THAT RULE By which bosses and workingmen can prosper withal. The common law cannot exist where the

When ordering to match type in case, send Cap "H" and L.C. "m"

THE H. C. HANSEN TYPE FOUNDRY



Lining Modern Antique No. 3

Standard Line

42-Point

4A \$3.00 8a \$3.25 \$6.25

**DESIGNS IN TYPE BY AN
Artist with stick and rule**

30-Point

6A \$2.40 12a \$1.85 \$4.25

STRONG MIND AND HEALTHY BODY
Result of physical culture and dieting
prescribed by reputable physicians 32

36-Point

4A \$2.40 8a \$2.00 \$5.00

SOLDIER MET FAIR CYNTHIA
Face powder on his uniform blue
Indulge in osculatory exhibit 23

48-Point

3A \$4.00 6a \$3.50 \$7.50

ONLY QUIET HOTELS
For old ladies or cranks

When ordering to match type in case, send Cap "H" and Lc. "m"

THE H. C. HANSEN TYPE FOUNDRY

Gothic No. 1

POINT LINE

18-Point

12A \$1.60 20a \$1.65 \$3.25

DEFTLY MANIPULATING TYPE, BORDERS AND BRASS Rule, the skilled compositor produces pleasing conceptions for the benefit and edification of intelligent advertisers 12345

6-Point No 1 (A) 37A \$1.00
CONSIDER THE GREAT ADVANTAGE OF POINT SYSTEM OVER THE METHODS PREVIOUSLY EXISTING IN THE REALM OF PRINTERROOM. THE OLD SYSTEM, OR RATHER, LACK OF SYSTEM, WHICH CHARACTERIZED THE EQUIPMENTS OF COMPOSING ROOMS AND CAUSED THE DOWNFALL OF MANY WEARY 4567 THIS SIZE ESPECIALLY ADAPTED FOR IMPRINTS

6-Point 30A \$1.00 50a \$1.00 \$2.00
TYPE WITH LARGE FACE ON SMALL BODY NEEDS LEADS Between lines and wider space between words. The readers want leaded type because it is easy to read; publishers order it, because the books so treated find readier sale. It is not in the power of

8-Point 25A \$1.05 50a \$1.20 \$2.25
ANY ONE MAN, HOWEVER HIGH HIS RATING AS An artist, to reverse this judgment. Indeed there is high authority for it. Ruskin has wisely said that the eye is not saddened by quantity of white, but 4

10-Point 22A \$1.20 44a \$1.30 \$2.50
A RESUMPTION OF THE GOLD EXPORT Movement to Germany showed the manifold demands for banking reserves. Another break in the price of copper was an unsettling 2345

12-Point 20A \$1.35 40a \$1.40 \$2.75
THE RAMPHORHYNCUS, WAS A Curious intermediate link between a bird and a reptile. Its remains have been found in some German quarries

HHHHHHH HHHHHH

**AUTOMOBILE
SUNDRIES**



MEADE MANUFACTURING COMPANY
Montreal ROXBURY, MASS. Chicago

6-PT. MULTIPLEX BORDER NO. 2 AUTOMOBILE ORNAMENT NO. 708

24-Point

7A \$1.90 10a \$1.60 \$3.50

LONG TALK TO PRACTICAL WORKMEN
By an eminent printer of international fame
The aim is to make this talk helpful and 78

THE H. C. HANSEN TYPE FOUNDRY

LINING GOTHIC

11A 18-Pt. No. 27 \$2.00
STEAMSHIPS CROSSING THE ATLANTIC 1234

9A 18-Pt. No. 28 \$2.00
ELECTRIC MOTORS FOR PRESSES 678

36A 6-Pt. No. 19 \$1.00
 VERY OFTEN PRINTERS NEED A SMALL GOTHIC LETTER TO MEET CERTAIN REQUIREMENTS; THIS SIZE IS PERFECTLY READABLE AND WILL MEET THE DEMAND MADE UPON IT FOR COMMERCIAL WORK AS WELL AS THE OTHER SIZES SHOWN ON THIS PAGE. THEY ARE TYPE FACES DESIGNED TO BE USED EVERY DAY IN THE WEEK AND WILL SURPRISE 123456

32A 6-Pt. No. 20 \$1.00
 THE H. C. HANSEN TYPE FOUNDRY AT 190-192 CONGRESS ST., BOSTON FURNISH COMPLETE PRINTING OUTFITS AT SHORT NOTICE, EVERYTHING BEING MADE UNDER ONE ROOF BY COMPETENT WORKMEN. HANSEN'S COMPLETE MITERING MACHINE, THE BEST IN THE WORLD, IS MADE HERE

26A 6-Pt. No. 21 \$1.00
 METAL QUOTATIONS CAST BY THIS FOUNDRY ARE ACCURATE TO POINT SYSTEM AND ARE VERY USEFUL TO PRINTERS ON ACCOUNT OF THE AMOUNT OF LABOR SAVED BY THEIR USE. CALL AND SEE HANSEN'S NEW MAMMOTH METAL FURNITURE

22A 6-Pt. No. 22 \$1.00
 SEND FOR SPECIMENS OF HANSEN'S BRASS RULES, SHOWING MANY ARTISTIC DESIGNS IN STIPPLED AND SHADED RULES, SUITABLE TO BE USED WITH ALMOST ANY FACE OF TYPE AND 6

THE
STERLING
 AND WHAT IT WILL DO

IS THE TITLE OF A
 BOOKLET TELLING
 ABOUT THE MERITS
 OF THIS MACHINE
 AND ITS USEFUL-
 NESS TO PRINTERS.
 ASK US ABOUT IT.



**THE H. C. HANSEN
 TYPE FOUNDRY**
 190-192 CONGRESS ST., BOSTON

22A 6-Pt. No. 23 \$1.00
 HANSEN'S TYPE IS THE STANDARD; FOR OVER A THIRD OF A CENTURY THE HANSEN SUPERIOR QUALITY HAS STOOD 89

18A 12-Pt. No. 24 \$1.50
 WHEN SEEKING A PRESS FOR HIGHEST QUALITIES OF PRINTING TAKE A LOOK AT COLT'S ARMORY PRESS 4

14A 12-Pt. No. 25 \$1.50
 REGARDING IT FROM A POINT OF VALUE WE CAN BUT SAY A TRIAL WILL

12A 12-Pt. No. 26 \$1.50
 WONDERFUL AS IT SEEMS THAT TRUTH IS MORE 246

8A 24-Pt. No. 29 \$2.50
COMPLETE PRINTING OUTFIT 6

6A 24-Pt. No. 30 \$2.50
A USEFUL JOB LETTER 28

THE H. C. HANSEN TYPE FOUNDRY



GOTHIC EXTRA CONDENSED

Standard Line

CHAMPIONS AGAIN SHUT OUT ST. LOUIS, SCORE 4-0

By Brilliant Pitching Tannehill Doesn't Let a Man Reach Third Base

ST. LOUIS, Aug. 30.—Again today the Boston champions not only defeated St. Louis, but did so without allowing St. Louis a run, 4 to 0 being the score.

Jesse Tannehill got back into his winning stride again and pitched brilliant ball. Not a St. Louis man saw third base and only two saw second. Never

once did St. Louis have a chance to win or to even score, and the home runs of Grimshaw and Freeman made it easy for the champions to land the jackpot.

NOW OUT FOR FIRST DIVISION

The two home runs took all interest out of the battle, as far as St. Louis was

WOMEN WANT CLEAN STREETS

Ella Wheeler Wilcox to Lead Aristocratic White Wing's Parade

NEW HAVEN, Aug. 31.—Mrs. Ella Wheeler Wilcox tomorrow will lead the women of Short Beach on a street cleaning parade. Armed with brooms, rakes, shovels and hoes, the women of the aristocratic summer resort will go from one end of the colony to the other, raking up waste paper and refuse or any kind that may mar the beauty of the thoroughfares.

Behind them will come a string of boys with wheelbarrows, who will remove the waste raked up by the female white wings. And the third detachment of the street cleaning army, made up of women armed with lead pencils and paper, will take note of the private residences that need attention.

ELECTRIC MOTORS FOR PRINTING PRESSES



YOUR ATTENTION, PLEASE

We are agents for Electric Motors—the best and cheapest power for printers. They are inexpensive, durable, always ready, cost little to operate and great time savers.

Actual demonstration shown in our foundry of the capabilities of these motors. We will be glad to tell you more about them.

The H. C. HANSEN TYPE FOUNDRY

190-192 Congress St., Boston

10-Point 30A \$1.15 55a \$1.35 \$2.50

THIS LETTER CAN BE USED IN VERY NARROW MEASURES
A useful display letter, very condensed, but easily read
is clean cut and adaptable where others cannot fit 123

12-Point 30A \$1.25 60a \$1.50 \$2.75

GREAT FAVORS CONFERRED UPON OUR ARTISTS
Who have achieved fame at home and abroad

14-Point 22A \$1.40 44a \$1.60 \$3.00

COMMOTION ARISING FROM MONOPOLIES
Controlling Commodities of the West 49

18-Point 15A \$1.50 30a \$1.75 \$3.25

BASE BALL ENTHUSIASTS 246
Make time pass quickly on Monday

24-Point 16A \$2.10 20a \$1.40 \$3.50

UNALTERABLE IN PURPOSE
And Unwavering in Manner 25

30-Point 10A \$1.90 18a \$2.10 \$4.00

GREATEST EMPORIUM
In the United States 72

36-Point 8A \$2.20 12a \$2.05 \$4.25

GOTHIC LETTER 8
Proper Display Line

48-Point 6A \$3.50 9a \$2.75 \$6.25

EXTENSIVELY
Purchased Goods

THE H. C. HANSEN TYPE FOUNDRY



GOTHIC CONDENSED No. 2

POINT LINE

24-Point

9A \$1.60 18a \$1.90 \$3.50

POWER IMPROVED PIN-HOLE PERFORATOR
 For durability, strength and general adaptability
 stands second to no other 123

18-Point

14A \$1.60 24a \$1.65 \$3.25

NEW BRASS RULE CORNERS MORTISED SQUARE
 To match any face of rule shown in any Specimen Book
 at regular rates and guaranteed 456

12-Point

18A \$1.25 36a \$1.50 \$2.75

BE SURE THAT ALL THE LEADS AND SLUGS USED IN YOUR
 OFFICE ARE MADE BY THE H. C. HANSEN TYPE FOUNDRY, BOSTON
 You will then always have them of equal height, thickness and
 perfectly square and smooth, which saves \$789

10-Point

20A \$1.20 40a \$1.30 \$2.50

PRINTING OFFICES MAKE MONEY WHOSE EMPLOYEES ARE ZEALOUS IN
 THE PERFORMANCE OF EVERY TASK AND NOT ALLOW JEALOUSY TO INTERFERE
 There is a certain class of compositors who feel that they ought not to be
 asked to set anything but the very highest grade of work 2

8-Point

24A \$1.10 48a \$1.15 \$2.25

THE HARRIS PERFECTION RULE CASE WILL HOLD ABOUT TWENTY POUNDS OF BRASS
 RULE CUT TO LABOR-SAVING LENGTHS. FOUR OF THEM FIT IN A BLANK CASE PERFECTLY 1234
 Printers are requested to call and examine this rule case as it is very compact, portable
 and a great improvement over other cases. Specify Hansen's Rule

HHHHHHHHHH

THE H. C. HANSEN TYPE FOUNDRY

GOTHIC CONDENSED No. 3

48-Point

4A \$3.15 7a \$3.10 \$6.25

ELOQUENT'S CLUB RECITALS

Make melody at twilight hour

18-Point

12A \$1.45 25a \$1.80 \$3.25

THE UNIVERSITY OF RHODE ISLAND
Reunion of graduates at Hotel Eclair

6-Point

25A \$1.00 50a \$1.00 \$2.00

THE FIRST THING FOR AN ADVERTISER TO DECIDE IS THE MEDIUMS WHICH REACH THE DESIRED CLASS OF Customers. Cheap mediums do not, as a rule, bring very good returns, neither does it follow that a periodical claiming a large circulation takes precedence over one with a smaller circulation.

24-Point

8A \$1.50 16a \$2.00 \$3.50

DESIGNED GREAT CATHEDRAL
Architects of renown in Portugal

8-Point

24A \$1.10 48a \$1.15 \$2.25

THE TONE OF A PUBLICATION AND CHARACTER OF ITS READERS DETERMINE MUCH. A FIRST-Class periodical with a bona fide paid circulation is far more desirable than a much larger sample copy circulation. People who buy a publication are very

30-Point

6A \$1.90 10a \$2.10 \$4.00

PROFITS MAY EVAPORATE
Like dew on July mornings

10-Point

20A \$1.15 40a \$1.35 \$2.50

MAKE ADVERTISEMENTS ATTRACTIVE, AND, IF LASTING RESULTS BE DESIRED, The goods must be as represented, and the advertisement honestly worded. Success in advertising depends largely in keeping

36-Point

5A \$2.00 9a \$2.25 \$4.25

POSITIVELY SUPERIOR
Quality our watchword

12-Point

16A \$1.20 32a \$1.55 \$2.75

YOUR NAME AND GOODS CONSTANTLY BEFORE THE EYE OF The public. Printer's ink is very beneficial to any business, but the use of good judgment and sense

42-Point

5A \$2.60 8a \$2.65 \$5.25

BAD EQUIPMENT IS INEXCUSABLE

Take your choice of a large variety

THE H. C. HANSEN TYPE FOUNDRY



GOTHIC CONDENSED No. 3 IN DISPLAY

ALLERTON'S CURIOSITY SHOP

The original Curiosity shop of Richfield, established in 1820 by Charles Allerton, where may be found a most complete line of beautiful and unique jewelry, gems of rare beauty and from places of historic interest, cuckoo and eight-day clocks, ancient Egyptian pottery, and fine Delft-ware from the famous shops of Holland.

CHARLES ALLERTON'S SON & CO.
Main and Duquesne Streets, Richfield, Illinois

12-Pt. Border No. 136

One Week Only

We have just received a fine lot of Delft Tea Sets worth \$45. A bargain at
\$21.98

THE H. C. HANSEN TYPE FOUNDRY
Type Wood Goods, Paper Cutters
Presses, Brass Rule, Etc.
Complete Printing Office Equipments
190-192 CONGRESS ST., BOSTON, MASS.

**Most Complete Line of
Wood Goods**

Wood Type
Rule and Type Cases
Cabinets
Stands, Etc.

**The H. C. Hansen
Type Foundry**
Boston New York

BONHAM NATIONAL BANK
Accumulation, Thrift and Wealth Streets
BONHAM, PENNSYLVANIA

Capital	\$375,000.00
Surplus and Undivided Profits	661,537.94
Deposits, June 29	976,643.21

Solicits deposits and business of all kinds, large and small. Citizens of Bonham and visitors are invited to call and inspect our banking rooms and facilities for doing business. Banking hours, 9 a. m. to 2 p. m.

THE H. C. HANSEN TYPE FOUNDRY

Gothic Condensed No. 400

STANDARD LINE

72-Point

3A \$3.70 5a \$3.00 \$6.70

HOUSE FURNISHING DAY

Bargains in all Departments

6-Point

35A \$0.85 70a \$1.15 \$2.00

THE DIMENSIONS OF BOOKS WHEN THEY WERE ALL PRINTED UPON THE HAND PRESS Were very well defined by the terms folio, quarto, etc. They were generally printed upon what is termed medium paper, 19x24 inches in dimensions. A sheet of this size, folded once, makes a folio; again, a quarto; still again, an octavo; then, a square 16mo; again, 32mo; and so on to 64mo, and even 128mo. Besides these sizes there are two intermediate, the 12mo and 18mo. The oblong 18mo was printed on a different sized sheet of paper, 18x28 inches in dimensions. The different sizes of books, therefore, measure

8-Point

35A \$0.95 70a \$1.30 \$2.25

THE DIMENSIONS OF BOOKS WHEN THEY WERE ALL PRINTED UPON THE HAND Press were very well defined by the terms folio, quarto, etc. They were generally printed upon what is termed medium paper, 19x24 inches in dimensions. A sheet of this size, folded once, makes a folio; again, a quarto; still again, an octavo; then, a square 16mo; again, 32mo; and so on to 64mo, and even 128mo. Besides these sizes, there are two intermediate, the 12mo and 18mo. The ob-

36-Point

6A \$1.95 12a \$2.30 \$4.25

THE SUBTERRANEAN DETONATIONS INCREASING

Peculiar phenomena noticed in connection with \$23

10-Point

31A \$1.10 65a \$1.40 \$2.50

THE DIMENSIONS OF BOOKS WHEN THEY WERE ALL PRINTED UPON The hand press were very well defined by the terms folio, quarto, etc. They were generally printed upon what is termed medium paper, 19x24 inches in dimensions. A sheet of this size, folded once, makes a folio; again, a quarto; still again, an octavo; then, a square 16mo; again, 32mo; and so on to 64mo, and even 128mo. Besides these

12-Point

28A \$1.25 56a \$1.50 \$2.75

THE DIMENSIONS OF BOOKS WHEN THEY WERE ALL Printed upon the hand press were very well defined by the terms folio, quarto, etc. They were generally printed upon what is termed medium paper, 19x24 inches in dimensions. A sheet of this size, folded once, makes a folio; again, a

48-Point

6A \$3.35 10a \$3.05 \$6.40

TREMENDOUS VOLCANIC ERUPTIONS

Important Communication Delayed 1369

THE H. C. HANSEN TYPE FOUNDRY

Gothic Condensed No. 400

STANDARD LINE

54-Point

3A \$3.50 5a \$2.50 \$6.00

UNEARNED FORTUNE ACQUIRED Old Liberty Enlightening the World

30-Point

9A \$1.90 17a \$2.10 \$4.00

**THE DIMENSIONS OF BOOKS
When They Were all Printed**

24-Point

12A \$1.65 26a \$1.85 \$3.50

**THE DIMENSIONS OF BOOKS WHEN
They were all printed upon the hand
press were very well defined by terms**

18-Point

17A \$1.45 36a \$1.85 \$3.30

**THE DIMENSIONS OF BOOKS WHEN THEY WERE
All printed upon the hand press were very well
defined by the terms folio, quarto, etc. They**

14-Point

22A \$1.40 46a \$1.60 \$3.00

**THE DIMENSIONS OF BOOKS WHEN THEY WERE ALL
Printed upon the hand press were very well defined
by the terms folio, quarto, etc. They were generally**

42-Point

6A \$2.60 11a \$2.65 \$5.25

HANSEN IMPROVED MITERING MACHINE

No Office Complete Without One. \$18.50

THE H. C. HANSEN TYPE FOUNDRY

111

Sterling Coated. See page 377

SHAKESPEARE'S COMEDY, THE

Merchant of Venice

Will be given by the members
of the

AMATEUR DRAMATIC ASSOCIATION

Wednesday, January 13, 1908
at 8 o'clock

OPERA HOUSE - GREENVILLE AVENUE



ALL SEATS RESERVED SECURE SEATS EARLY

Tickets, admitting Two, \$1.00

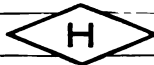

CONDENSED GOTHIC No. 400 IN DISPLAY

CLEARANCE SALE OF POPULAR BOOKS

BREAKING INTO SOCIETY

By **GEORGE ADE**. A bright series of fables in that crisp style which has made all his former works of this character so popular

Illustrated, Cloth **\$1.50**

MRS. RAFFLES

By **JOHN KENDRICK BANGS**. Mr. Bangs has most amusingly recounted the burglaries and adventures in which Mrs. Raffles leads

Illustrated, Cloth **\$1.00**

KATE: A COMEDY

By **BRONSON HOWARD**. Whether love or worldly advantage shall influence marriage is the general theme of this delightful play

Cloth, Untrimmed Edges **\$2.50**

SPECIAL BARGAIN

Les Miserables

We have been fortunate in securing from a well known publishing house a limited number of sets of Victor Hugo's masterpiece. They come in two volumes, handsomely printed on hand-made deckle edge paper, with rubricated initials. The illustrations are the finest duo half-tones from the drawings by Christy. Bound in limp leather with stamped sides and back

Per Set **\$4.29**

6-PT. O. S. 112

THE WONDERS OF LIFE

By **ERNST HAECKEL**. A new, supplementary volume to *The Riddle of the Universe*, a popular study of the mysteries of life. Illustrated

Half Leather, net **\$0.98**

CAMP LIFE IN THE WOODS

By **W. N. GIBSON**. Comprehensive hints on building camps, canoes, traps of all kinds together with all the professional tricks

Illustrated, Cloth **\$0.95**

BEN HUR: A Tale of the Christ

By **LEW WALLACE**. An elaborate edition, for which a demand has been created by the long runs of the play "Ben Hur." Cloth

Illustrated, Two Volumes **\$3.98**

JORDAN-SEIGEL CO., Broadway and Ninth Streets

THE STERLING ROUND CORNERING MACHINE

PRICE, \$150

TELEPHONE MAIN 1224

M

FOR SALE
H. C. HANSEN TYPE
BOSTON AND NE

THE H. C. HANSEN TYPE FOUNDRY

MANUFACTURERS

Type, Borders and Ornaments
Hansen Complete Miterer and
Rule Curver; Hansen Improved
Pin Hole Perforator; All-Brass
Riveted Galleys, Brass Rule

190 - 192 CONGRESS STREET
BOSTON, MASS.

Type

To THE W. C. WILLIAMS CO., Dr.
THE "W. C. W. BRAND" STEEL TOOLS

Wholesale and Retail

No. 66 FANEUIL HALL SQUARE

THE H. C. HANSEN TYPE FOUNDRY

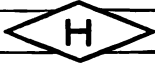
**INCLINED GOTHIC**

POINT LINE

26A 6-Pt. No. 40 \$1.00
**PRESCRIPTIONS CAREFULLY COMPOUNDED FROM LEAD
 TIN, COPPER AND THE FINEST ANTIMONY
 PRODUCE GOOD WEARING TYPE**

24A 6-Pt. No. 41 \$1.00
**FIGURES ARE CAST BY THIS FOUNDRY ON POINT SET
 FOR EASY JUSTIFICATION ON CALENDAR
 AND TABULAR COMPOSITION**

21A 6-Pt. No. 42 \$1.00
**MODERN IMPROVEMENTS IN MANUFACTURING
 TYPE OF THE HIGHEST STANDARD
 SECURE SURE RESULTS**

18A 6-Pt. No. 43 \$1.00
**LARGE SALARIES PAID TO SUPERVISORS
 AND FOREMEN OF PRINTSHOPS
 WITH BRAINS AND PUSH**

18A 12-Pt. No. 44 \$1.50
**FIRST GRAND ENTERTAINMENT OF
 THE DARKTOWN SOCIETY
 HELD IN BINGVILLE**

17A 12-Pt. No. 45 \$1.50
**OLD ORCHARD BEACH PIER
 MASCONOMA HOUSE
 OPEN IN JUNE**

11A 12-Pt. No. 46 \$1.50
**EIGHTEENTH SEASON
 GRAND OPERA
 BOSTON**

250 ROOMS WITH BATH
 AND ELECTRIC LIGHTS



SPECIAL RATES TO
 LARGE PARTIES

RED LION HOUSE

NORTH ADAMS, MASS.

GEO. TRAVIS, PROPRIETOR

10A 18-Pt. No. 47 \$2.00
**A SWEET LINGERING MUSICAL SOUND
 MANDOLIN AND GUITAR 45**

8A 18-Pt. No. 48 \$2.00
**THE SEVENTH GRAND RECITAL
 BY TWELVE MUSICIANS 12**

6A 24-Pt. No. 49 \$2.50
BREEZES TURN TIDES 4

THE H. C. HANSEN TYPE FOUNDRY



GOTHIC No. 6

POINT LINE

18-Point

8A 16a \$3.25

Caps \$1.60 l.c. \$1.65

SPECIAL FIGURES FOR TIME TABLES
 The H. C. Hansen Type Foundry has ever been
 foremost in providing for printers labor-saving 12

6-Point No. 6 (A) 24A 50a \$2.00 Caps \$0.90 l.c. \$1.10

**SYSTEMS WHICH PROVIDE A MUTUAL EXCHANGE OF COMMODITIES
 ARE MANIFESTLY ESSENTIAL TO CONTINUED GROWTH OF TRADE**

We must not repose in fancied security that we can forever sell every
 thing and buy little or nothing. If such a thing were possible it would
 not be best for us or those with whom we deal. We should take from
 our customers such of their products as we can readily use 3456789

6-Point No. 6 (B) 24A 50a \$2.00 Caps \$0.90 l.c. \$1.10

**REMEMBER THAT WHATEVER IS WORTH DOING AT ALL
 IS WORTH DOING WELL AND NEVER ALLOW YOURSELVES**

to be rushed to such an extent as to do your work in a slovenly
 manner, because habit once formed will become second nature to
 you in the course of time. You may not be endowed with \$123

6-Point No. 6 (C) 22A 44a \$2.00 Caps \$1.00 l.c. \$1.00

**ORIGINALITY DOES NOT MEAN THAT YOU MUST
 CREATE SOMETHING NEVER BEFORE HEARD OF**

To follow the path of others who have been successful
 is but another way of educating yourself in a sort of
 school of advertising. Plain words are sure to hit the
 bull's-eye. One of the great disadvantages that super-
 educated people, the majority of advertisers, have to
 overcome is the tendency to display their entire vo-
 cabulary. It is true that it requires a great deal more
 skill to be simple than to be profound. Now, then, to
 begin with, fix what you intend to convey permanently
 within your mind, then say it in a few words as possi-
 ble, pert and to the point. The fewer the better 456

GIGANTIC SALE OF

FINE CLOTHING

Owing to an extensive purchase of Fall and Winter
 Clothing, we have decided to close out our stock of
 Summer Goods at greatly reduced prices. Many suits
 are priced below cost rather than carry them over for
 another season. This stock consists of the highest
 grade clothing, and you cannot realize how much we
 are sacrificing until you see the prices.

An Unusual Opportunity

**Black Worsted
 Suits at \$7.98**

BROWN & SMITH
 36 FRONT ST., PORTLAND, ME.

High Art Brass Rule No. 12 711

8-Point

16A 32a \$2.25

Caps \$1.05 l.c. \$1.20

**FOR ANYTHING IN TYPE, BORDERS, ORNAMENTS, BRASS RULE, METAL FURNITURE
 and Printers' Supplies, call at The H. C. Hansen Type Foundry, 190-192 Congress Street, and
 get the benefit of thirty-five years of experience in practical type founding and rule making 8**

THE H. C. HANSEN TYPE FOUNDRY



GOTHIC No. 6

POINT LINE

48-Point

3A 4a \$7.50

Caps \$4.50 l.c. \$3.00

**TYPE WORLD
Issued on the 29**

36-Point

4A 5a \$5.00

Caps \$3.00 l.c. \$2.00

**SELECT TYPE FACE
from Hansen, Boston 35**

24-Point

5A 9a \$3.50

Caps \$1.60 l.c. \$1.90

**LOOK FOR DIAMOND NICK
Whenever You Purchase Type 46**

12-Point

13A 26a \$2.75

Caps \$1.25 l.c. \$1.50

**A PRINTER'S STATIONERY SHOULD
REPRESENT HIS BEST EFFORTS 42**
Something a little above the ordinary is expected of a printer in the preparation and execution of his office stationery, &c

H H H H H H H H H H H H

10-Point

16A 30a \$2.50

Caps \$1.15 l.c. \$1.35

**THE THEORY OF APPROPRIATE TYPES
SHOULD BE OBSERVED AT ALL TIMES**
Good judgment should be a factor in the application of types, and it is not meet to say in the old-fashioned way that a milliner's card 7

**THE BEST
TYPE**

Because great care is exercised in mixing the metals and also in casting, Hansen's Type has won a reputation for good wearing qualities. The "Diamond Nick" type is the kind you should have in your cases. Made only by

**THE H. C. HANSEN
TYPE FOUNDRY**

THE H. C. HANSEN TYPE FOUNDRY



MEDIUM GOTHIC No. 7

STANDARD LINE

60-Point

3A 4a \$9.00

Caps \$5.35 l.c. \$3.65

FREIGHT Paid \$15

Oswego
Paper Cutters

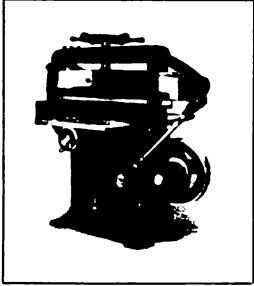

Both Lever and Power

**THE H. C. HANSEN
TYPE FOUNDRY**

Selling Agents

The line "Oswego" above is Boston Gothic

30-Point

7A 10a \$4.25

Caps \$2.15 l.c. \$2.10

GREAT HANDICAP Race started at 2

24-Point

7A 15a \$3.50

Caps \$1.55 l.c. \$1.95

NEW SERIAL STORIES Are now being forced upon the readers of 6

14-Point

15A 31a \$3.00

Caps \$1.35 l.c. \$1.65

GREAT SALE NOW TAKING PLACE at the shoe store of Fitem Brethers where a choloe can be made for \$1

10-Point

23A 46a \$2.50

Caps \$1.15 l.c. \$1.35

THESE PLAIN, BOLD LETTERS, MADE BY HANSEN
are types of merit. Whon used in advertisements
those letters carry weight which causes the reader
to believe the truths so printed. Medium Gothic 3

6-Point

30A 60a \$2.00

Caps \$0.95 l.c. \$1.05

NO ORDER TOO LARGE TO BE HANDLED PROMPTLY BY THIS FOUNDRY
And small orders receive also the same prompt and careful attention, as
we realize the importance to printers of even a slight delay in work, we
use our best efforts to meet every rush order, be it large or small 12345

42-Point

4A 6a \$5.40

Caps \$2.90 l.c. \$2.50

DEMAND GOTHIC LETTERS For Results in Advertising 3

Medium Gothic No. 7 will register with Boston Gothic for color work.

THE H. C. HANSEN TYPE FOUNDRY



MEDIUM GOTHIC No. 7

STANDARD LINE

72-Point

3A 4a \$9.60

Caps \$5.70 l.c. \$3.90

CHARGE Low 2

36-Point

5A 9a \$4.75

Caps \$2.40 l.c. \$2.35

**SECOND HEAT
Of the Final 43**

18-Point

11A 22a \$3.25

Caps \$1.45 l.c. \$1.80

**NO HAIR LINES TO BREAK
Are found in this series of
Bold Gothic Letters, which
make them admirable 567**

12-Point

19A 38a \$2.75

Caps \$1.20 l.c. \$1.55

**HANSEN'S COMPLETE MITERING MACHINE
Has been accepted by printers as the best
machine in the world for mitering brass rule
as it is set by a pin, no lines to guess at 18**

8-Point

27A 53a \$2.25

Caps \$1.00 l.c. \$1.25

**COMPLETE PRINTING OFFICE EQUIPMENTS SUPPLIED QUICKLY
By The H. C. Hansen Type Foundry at 190-192 Congress Street.
All type being cast under one roof, the advantages to printers
when ordering sorts are at once apparent, and many times 2369**

TYPE

Of the many Ad-Types on the market there are none which can bring the advertiser better results than Medium Gothic No. 7, the complete series being herewith shown, and Besten Gothic, specimens being shown on following pages

THE
**H. C. Hansen
Type Foundry**

48-Point

4A 6a \$7.00

Caps \$3.75 l.c. \$3.25

**MEDIUM GOTHIC No. 7
A Convincing Proof 89**

Medium Gothic No. 7 will register with Boston Gothic for color work.

THE H. C. HANSEN TYPE FOUNDRY



BOSTON GOTHIC

Standard Line

72-Point

3A 4a \$11.50

Caps \$6.75 l.c. \$4.75

18-Point

12A 18a \$3.20

Caps \$1.75 l.c. \$1.45

ONE Line

GREAT ADVANTAGES
Over Competitors may
signify shrewdness 2

Telephone 30 Maine

Portland, Me. _____ 190

M _____

To DOUGLAS & MANNING, Dr.

Our Clothing is all made
by first-class workmen
under direct supervision

Clothiers
Men's Furnishers

28 Vestry Street

ESTABLISHED 1872

'PHONE, 2738 MAIN

The H. C. Hansen Type Foundry

—TYPE—
Manufacturers and Designers

190-192 Congress Street

Boston, Massachusetts

Boston Gothic

Is a practical, all around good
sense letter for jobwork, and
may be kept moving con-
tinually, as it is also
very adaptable for
advertising.



BOSTON GOTHIC IN COLOR WORK

Hansen's Medium Gothic No. 7 will register accurately with the Boston Gothic for color. The two series in conjunction will produce some very fine color combinations

48-Point

4A 6a \$7.30

Caps \$4.00 l.c. \$3.30

A COMPLETE Series 8

THE H. C. HANSEN TYPE FOUNDRY



BOSTON GOTHIC

Standard Line

24-Point

9A 12a \$3.75

Caps \$2.00 l.c. \$1.75

60-Point

3A 4a \$9.50

Caps \$5.75 l.c. \$3.75

ROAD TO WEALTH
Has Few Secrets 3

High ART

36-Point

6A 9a \$5.00

Caps \$2.75 l.c. \$2.25

ADVERTISING Patronage

<p>SALE OF MEN'S FINE HATS</p> <hr/> <p>BLACK & GREY 36 HIGH STREET, PEORIA, ILL.</p>	<p>Tuesday, Jan. 2</p> <p>WE inaugurate the greatest sale of Men's high grade Hats ever known in the history of our business. We guarantee these goods to be in perfect condition and all going this week at</p> <p>\$1.50</p>
---	--

30-Point

7A 10a \$4.25

Caps \$2.15 l.c. \$2.10

CIRCULATION for May 12,345

42-Point

4A 6a \$5.40

Caps \$2.90 l.c. \$2.50

BOSTON GOTHIC Letters 5

Boston Gothic will register with Medium Gothic No. 7 for color work.

THE H. C. HANSEN TYPE FOUNDRY

GOTHIC ITALIC

Standard Line

6-Point 18A 36a \$2.00 Caps \$1.00 l.c. \$1.00

**MODERN PRINTING OFFICES ON THE POINT SYSTEM
Are a paying investment when equipped with all of
Hansen's type, material and labor-saving devices**

8-Point 15A 30a \$2.25 Caps \$1.00 l.c. \$1.25

**CONSIDER THE GREAT VARIETY OF WORK
which it is possible to do with this type
and note the strength of the figures 78**

10-Point 12A 25a \$2.50 Caps \$1.20 l.c. \$1.30

**GOTHIC ITALIC TYPE IS CLEAR OUT
and has already won favor among
printers as a useful jobbing letter**

12-Point 10A 20a \$2.75 Caps \$1.35 l.c. \$1.40

**GREAT RESULTS EXPECTED
from the superb production
of "Ben Hur" new playing 9**

Beveled Quads and Quotations

**Time and labor saved.
Difficult Composition
very easily attained.**

ORIGINATED AND MADE BY

**THE H. C. HANSEN TYPE
FOUNDRY, BOSTON, MASS.**

60-Point

3A 4a \$11.50

Caps \$6.75 l.c. \$4.75

A STRIKING

18-Point

8A 14a \$3.25

Caps \$1.60 l.c. \$1.65

**ADVERTISEMENTS FOR DAILY NEWSPAPERS
Set in Gothic Italic bring quick returns \$1234**

24-Point

6A 10a \$3.50

Caps \$1.80 l.c. \$1.70

**RETURNED FROM THE NEVADA MINE
Laden with wealth and oxperienco 56**

30Point

4A 6a \$4.25

Caps \$2.25 l.c. \$2.00

**REMEMBERS OLD FRIENDS
With gifts unique and rare**

THE H. C. HANSEN TYPE FOUNDRY



GOTHIC ITALIC

Standard Line

48-Point

3A 4a \$7.75

Caps \$4.75 l.c. \$3.00

SPURIOUS COIN Silver Dollars 8

36-Point

3A 5a \$5.00

Caps \$2.75 l.c. \$2.25

LARGE CIRCULATION Winona Daily Tribune

60-Point

3A 4a \$11.50

Caps \$6.75 l.c. \$4.75

Ad. Letter 4

OUT TO-DAY

MOTOR

**A MAGAZINE
OF SPORT**

*Read the new serial story.
Something to interest every
owner of an automobile, or
motor cycle of any kind.*

**AT ALL
NEWS-STANDS**

Hansen's Ad. Corners Send for Specimens

HUSTLE

A STORY FOR AMERICAN BOYS
By James Thomas

\$1.50

HAYWARD & MILLER, Publishers
38 LONGREEN AVE., BOSTON, MASSACHUSETTS
"All the Books for All the Boys"

THE H. C. HANSEN TYPE FOUNDRY



Lining Gothic No. 18

STANDARD LINE

36-Point

4A 7a \$5.20

Caps \$2.65 l.c. \$2.55

POPULAR Indian Melodies

42-Point

4A 6a \$6.50

Caps \$3.50 l.c. \$3.00

PLAYED in all Concerts

6-Pt. 22A 44a \$2.00 Caps \$0.90 l.c. \$1.10

BOATING A DELIGHTFUL SPORT
When pressure of business becomes heavy, and you feel the urgent need of a rest, take a trip to the country and amid the quiet surroundings spend \$2

10-Pt. 16A 32a \$2.50 Caps \$1.20 l.c. \$1.30

THE OUT-DOOR LIFE IS A boon to tired city workers and a trip to the mountain repays them for their year

14-Pt. 12A 24a \$3.00 Caps \$1.40 l.c. \$1.60

UNDAUNTED BY rain they take long walks over the hills

24-Pt. 5A 11a \$3.50 Caps \$1.65 l.c. \$1.85

ALL NIGHT do they sleep soundly, tired

Correct Styles

SPRING SUITS

PROMPT SERVICE
COURTEOUS TREATMENT
PRICES RIGHT



CUTT & SOWE
44 Taylor Street
BOSTON MASS.
Printers' Joy No. 5. Each \$0.10

8-Pt. 20A 40a \$2.25 Caps \$1.10 l.c. \$1.15

GRAND EXCURSIONS TO THE White Mountains during Summer months, reasonable rates to all excursion parties for any

12-Pt. 14A 28a \$2.75 Caps \$1.25 l.c. \$1.50

THE VACATIONIST Will have use of Golf Links and Lawn Tennis Courts free of charge

18-Pt. 9A 18a \$3.25 Caps \$1.75 l.c. \$1.50

LAKES, PONDS and Rivers full of Happy Canoeists

30-Pt. 5A 8a \$4.25 Caps \$2.20 l.c. \$2.05

BEAUTY of Natural panorama

48-Point

3A 6a \$7.80

Caps \$4.00 l.c. \$3.80

The Fast EXPRESS

54-Point

3A 5a \$8.75

Caps \$4.85 l.c. \$3.90

LEAVES at 9.30

When ordering to match type in case, send Cap "H" and l.c. "m"

THE H. C. HANSEN TYPE FOUNDRY

NEW YORK GOTHIC

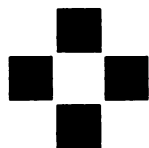

A SUPERIOR QUALITY PRODUCTION OF

THE H. C. HANSEN TYPE FOUNDRY

ESTABLISHED 1872

190-192 CONGRESS STREET, BOSTON
43 CENTRE STREET, NEW YORK

EDUCATOR BORDER AND CORNERS

NEW YORK GOTHIC

STANDARD LINE

**You Ought to Own an
AUTO**



**SPECIAL
SLOMOBILE
\$325.00**

Splendid 1910 Model
A \$900 Car. Perfect
Repair. Little Used.

**We are agents
for several of
the most reli-
able machines
at prices from
\$550 to
\$6,500**

**Best facilities
for the care or
repair of autos**

The Best Garage
704 Speedwell Boulevard, Memphis, Tenn.

6-Point 20A \$0.95 40a \$1.05 \$2.00
RAPID INCREASE OF SUBSCRIPTION LIST DENOTES
The interest of readers and proves the value as a medium
for presenting the messages of advertisers to the public

8-Point 20A \$1.05 40a \$1.20 \$2.25
ENTERPRISES FAULTLESSLY CONSUMMATED
Gigantic Undertakings Impossible in the Old World
Flourishing in New York. Failure Unknown Quantity

10-Point 16A \$1.15 32a \$1.35 \$2.50
PRINTING INDUSTRY PROSPERS
The Headquarters of Many Periodical
and Book Publishers of Great Renown

12-Point 13A \$1.35 26a \$1.40 \$2.75
THE HANSEN TYPE FOUNDRY
Manufacturer and Purveyor of the
World's Best Printing Materials 4

14-Point 11A \$1.45 22a \$1.55 \$3.00
HUDSON RIVER SCENES
Majestic Steamships Gliding
Banks of Verdant Beauty 58

18-Point 8A \$1.60 17a \$1.65 \$3.25
NEW STONE BRIDGES
Highway for a Multitude

24-Point 6A \$1.85 11a \$1.65 \$3.50
STRIVING TO WIN
Pursuit of Riches \$1

30-Point 5A \$2.50 8a \$2.00 \$4.50
GREAT FINANCIAL CENTERS
Securities Increasing in Value \$5

36-Point 4A \$2.85 6a \$2.15 \$5.00
BUILDING TORN DOWN
Retail Merchant Speculates

THE H. C. HANSEN TYPE FOUNDRY

NEW YORK GOTHIC

STANDARD LINE

42-Point

3A \$3.45 6a \$2.95 \$6.40

REDUCE THE PRICE
Shelves Quickly Cleared

48-Point

3A \$4.55 5a \$2.95 \$7.50

KIND WORD SAID
Rich Medal of Bronze

60-Point

3A \$7.00 4a \$4.00 \$11.00



BRUSH WORK
Reform Purpose

72-Point

3A \$8.10 4a \$4.70 \$12.80

BEST CURE
Nature Study

THE H. C. HANSEN TYPE FOUNDRY

**HANDCRAFT
FURNITURE**

FRED STONE
EAST LEBANON
MICHIGAN





MCMXI

6-PT. EDUCATORS NO. 1
SWASTIKA ORNAMENTS

Cut Prices
All This Week



**At
Ripley's**
 Hardware
 Store
 Oxford, Va.

BERKSHIRE ORN. NO. 177. 50C.

Experimental Work
 a Specialty

Telephone 136-L

HOLMES & JACKSON CO.
Machinists

MANUFACTURERS OF THE CELEBRATED "ZIM" MOTOR
 THE RELIABLE MOTOR FOR LAUNCH OR AUTO



■ ■ ■

18 RIVER STREET, BRISTOL, R. I.

Represented by THOS. B. WHITE

New York Gothic

THE PLANT THAT PRODUCES
DOLLARS

Is the Printing Plant which is equipped
 with products of New England's Only
 Manufacturing Type Foundry, The

H. C. HANSEN TYPE FOUNDRY

8-PT. EDUCATORS NO. 2
72-PT. ALADDIN ORN. NO. 8. 85C.

EXTENDED LINING GOTHIC

30-Point No. 930

3A \$3.00 5a \$2.20 \$5.20

**MAKER
of Boots**

24-Point No. 924

4A \$2.25 6a \$1.75 \$4.00

**IN VENICE
by Gondola**

18-Point No. 918

6A \$1.75 10a \$1.75 \$3.50

**ELEVATORS
are used the
most in Paris**

14-Point No. 914

6A \$1.35 12a \$1.65 \$3.00

**GOODS, DRY &
Wet, for all who
have Vacations**

WE MAKE
TYPE
OF SUPERIOR
QUALITY



The
H. C. Hansen
Type Foundry

The
Banner

is one of the oldest and best
known papers in Para County

—

Average circulation
for month of March

34,275

—

Advertisers get

Results

12-Point No. 912

6A \$1.25 14a \$1.50 \$2.75

**MERRY MAIDEN
And the milk pail
Down on the farm**

10-Point No. 910

8A \$1.10 18a \$1.40 \$2.50

**NORTH MOUNTAINS
Situated near Henry
Pass, Shiphabor, N.S.**

8-Point No. 908

10A \$1.10 20a \$1.15 \$2.25

**THE COMMONWEALTH &
Of Massachusetts, Boston,
the leading shopping center**

6-Point No. 906

10A \$0.90 21a \$1.10 \$2.00

**THE CHASE FOR MILLIONS
Rich and poor are chasing after
the almighty dollar continually \$**

THE H. C. HANSEN TYPE FOUNDRY



GOthic CONDENSED NO. 5

POINT LINE

42-Point

8A \$3.75

FAMOUS MIRTH PROVOKING MINSTREL

36-Point

8A \$3.00

QUICK RETURNS AND MODERATE PROFITS

6-Point

36A \$1.00

THE DAILY PRESS BEING THE MOULDER OF PUBLIC OPINION IT IS CERTAINLY DESIRABLE THAT THE REPRESENTATIVES OF THAT GREAT POWER SHOULD BE ARMED AND EQUIPPED WITH

8-Point

32A \$1.25

BROAD AND COMPREHENSIVE VIEWS RELATING TO THE OUTSIDE WORLD. DESOLATION BEGETS NARROW-MINDEDNESS AND TOTAL UNFITNESS

10-Point

30A \$1.50



TO GRAPPLE WITH THE PROBLEMATICAL SUBJECTS WHICH AFFECT THE MASSES. WHAT THE PRESS HAS DONE AND IS NOW

12-Point

25A \$1.50

DOING FOR THE MENTAL DEVELOPMENT OF THE COUNTRY, THE RAILROADS ARE DOING FOR THE COMMERCIAL DEVELOP





DID YOU EVER STOP TO THINK?

Sickness and accident are of daily occurrence and happen to all classes of men.

PROTECT YOUR POCKET

by insuring in the Acme Casualty Co. Our policies are simple, without conditions, and offer complete protection.

ACME CASUALTY CO.
HAWK SHAW, NEW BRUNSWICK

18-Point

22A \$2.00

20-Point

18A \$2.25

EXCITING ADVENTURES OF THOMAS QUIRK
PUBLISHED BY DUNCAN-MEAD CO. IN 1863

WARM CLOTHING AT MONEYSKI'S
LOW PRICES DURING MARCH 1907

24-Point

14A \$2.50

WINTER EXCURSION TO NATICK VIA BOSTON & ALMOST

48-Point

5A \$4.00

LAST SUITOR WON FAIR LUCY

THE H. C. HANSEN TYPE FOUNDRY

GOTHIC CONDENSED NO. 4

6-Point 36A \$1.00 60a \$1.00 \$2.00

ALL MODERN IMPROVEMENTS IN PRINTING SUPPLIES
Furnished by The H. C. Hansen Type Foundry, 190-192
Congress Street, Boston, where all orders receive our

8-Point 28A \$1.10 60a \$1.15 \$2.25

THE MECHANICAL ART OF PRINTING FOR ALL
Interested in fine work has developed to a great
extent and workmen continually improving 3784

10-Point 25A \$1.20 60a \$1.30 \$2.50

VIEW NEAR WHITE HILL AND ELMIRA
Is the most picturesque to eyes of 234

12-Point 21A \$1.25 42a \$1.50 \$2.75

LEADING SUMMER GLOVE WEAR
For sale on Washington Street, \$2

18-Point 15A \$1.40 36a \$1.85 \$3.25

WELLINGTON HILLSIDE FARM
Lots to suit every purchaser

20-Point 12A \$1.50 22a \$1.75 \$3.25

CUNIO TRANSATLANTIC
Steamship Transportation

24-Point 8A \$1.65 16a \$1.85 \$3.50

VILLAGE SMITHEY
The man of might

36-Point 5A \$1.90 10a \$2.35 \$4.25

MILLSTREAM
By your doors

42-Point 5A \$2.35 10a \$2.90 \$5.25

WIRE Screen

48-Point 4A \$2.75 9a \$3.50 \$6.25

GREAT Art

We Make and Sell "The Very Best for the Man Who Prints"

HAMILTON WOOD GOODS

Are considered the best in
their class. We have re-
cently received a carload
of Cases, Stands, Labor
Saving Wood Furniture, etc.

PRINTERS' COMPLETE EQUIPMENTS

The H. C. Hansen Type Foundry

190-192 CONGRESS ST., BOSTON 43 CENTRE STREET, NEW YORK

Gothic Condensed

No. 4

A LETTER
INDISPENSABLE IN ANY
PRINTING OFFICE

FOR many years has
this type been deemed
an absolute necessity in
every printshop. With
due respect for more re-
cent type faces, Gothic
Condensed has never
been supplanted by any
similar kind of Gothic

CONSTERNATION IN THE PRINTING TRADE

Mr. Isaac Lovering Blanchard
Arrives from New York and
Delivers a Lecture on
Conditions, Etc.

AT THE CROWN HOTEL

Mr. Blanchard demonstrates to his
audience very forcibly the condi-
tions that are to be contended with

THE H. C. HANSEN TYPE FOUNDRY

THE CAMBRIDGE SERIES

Standard Line

48-Point

3A 6a \$7.10

Caps \$3.75 l.c. \$3.35

DETROIT UNIVERSITY Great Educational Center

**GREAT STAR
INVESTMENT CO**

THE CAPITALIZATION IS \$130,000.00



THIS Company is
organized under
New Jersey laws.
Shares are \$1 each

6-Point 24A 48a \$2.00 Caps \$1.00 l.c. \$1.00

A VERY IMPORTANT ITEM IN PRINTING OFFICE EXPENSE IS THE MATTER Of ink, and yet it is often overlooked entirely in the estimating on work. It is understood, of course, that in the majority of jobs, the ink expense forms but a proportionally small part of the cost, but that is no reason why it should be

8-Point 20A 40a \$2.25 Caps \$1.00 l.c. \$1.25

LEFT OUT OF OUR CALCULATIONS ENTIRELY, FOR THERE Are times when it forms a large proportion, and if we get into the habit of neglecting it all the time, the chances are that we shall forget it when it should be thought of. Practical Printers should

10-Point 18A 36a \$2.50 Caps \$1.15 l.c. \$1.35

MEN'S FURNISHINGS FOR SALE WEDNESDAYS
Fast color, plain black and colored Half Hose, sizes 6 to 12, double toe and heel. A Genuine Bargain

12-Point 16A 32a \$2.75 Caps \$1.25 l.c. \$1.50

ALL THE TYPE FACES IN THIS CATALOG
Are cast from Hansen's Superior "Copper Amalgam" type metal which gives lasting

14-Point 14A 28a \$3.00 Caps \$1.40 l.c. \$1.60

THE "PERFECTION" RULE CASES
Will hold about 20 pounds of labor-saving brass rule. Ask to be shown

Notice the legibility of the figures

\$ 1234567890 \$

36-Point

4A 7a \$4.60

Caps \$2.45 l.c. \$2.15

FINE BIOGRAPHICAL SKETCH Of Dickens in Two Large Volumes

THE H. C. HANSEN TYPE FOUNDRY

THE CAMBRIDGE SERIES

Standard Line

60-Point

3A 4a \$8.70

Caps \$5.40 l.c. \$3.30

**MANUFACTURERS
Increase Their Stock**

18-Point

9A 18a \$3.25

Caps \$1.50 l.c. \$1.75

CAMBRIDGE A BEAUTIFUL TYPE
Its Clean Cut Appearance Will Make
it useful for a large variety of work

24-Point

6A 12a \$3.50

Caps \$1.75 l.c. \$1.75

**PRINTING MATERIAL OF
All Kinds Made by Hansen**
Goods are delivered promptly

30-Point

5A 10a \$4.15

Caps \$2.00 l.c. \$2.15

RED BRICKHOUSES
Built In Eight Weeks
Sun on all four sides

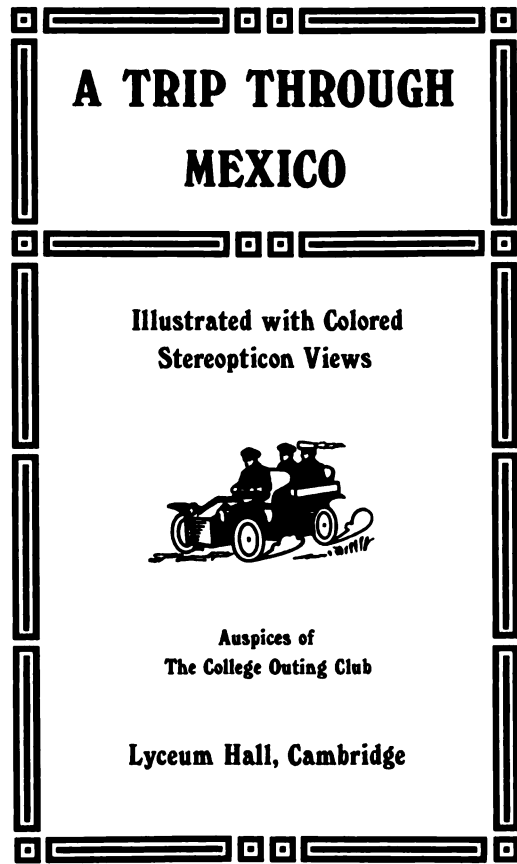

12-Point Runlon Border. 54 inches, \$1.50

72-Point

3A 4a \$11.30

Caps \$7.00 l.c. \$4.30

LARGE Figures

THE H. C. HANSEN TYPE FOUNDRY

MASTODON SERIES

Standard Line

10-Point

18A \$1.10 36a \$1.40 \$2.50

THE COMPLETE MITERING MACHINE IS MADE BY H. C. HANSEN TYPE FOUNDRY
As the name suggests it is complete and accurate in every respect. Printers who use it are enthusiastic in its praise. So constructed that guess work is eliminated

12-Point

15A \$1.25 30a \$1.50 \$2.75

PRINTERS OBTAIN NOVEL EFFECTS WITH H. C. HANSEN'S NEW DEVICES
The beveled quads, cutting dies made of steel rule blocked in metal and the halftone and ornamental brass rules

18-Point

9A \$1.45 18a \$1.80 \$3.25

MERCHANT RECOGNIZES VALUE OF BOLD DISPLAY
Various new and catchy ways to advertise his wares are sure to eliminate summer stagnation of business

24-Point

5A \$1.35 12a \$2.15 \$3.50

HISTORY OF THE MERCHANT MARINE
Foreign products obtained at great risk from distant lands beyond the deep sea

30-Point

5A \$2.00 9a \$2.25 \$4.25

THIRTY BARGAINS AT LEHR'S
Advertised in morning papers
All merchandise below cost \$23

36-Point

4A \$2.40 6a \$2.60 \$5.00

MASTODON IS THE TYPE
For strong, legible display advertisements. Fashions

THE H. C. HANSEN TYPE FOUNDRY



MASTODON SERIES

Standard Line

42-Point

4A \$3.25 6a \$3.00 \$6.25

STRONG AND LEGIBLE
a display of type faces

48-Point

3A \$4.10 5a \$3.40 \$7.50

NOTED SIGNATURE
delightful journeys

60-Point

3A \$6.00 4a \$4.50 \$10.50

FISH MARKETS
scup or halibut

72-Point

3A \$7.50 4a \$5.50 \$13.00

GAY DELUTH
finest work 7

All Hansen Type cast from Superior Copper Alloy Metal

THE H. C. HANSEN TYPE FOUNDRY

MASTODON SERIES SHOWN IN DISPLAY

FUEL SAVERS - BUILT TO BAKE THE BUTLER RANGES

Baking uncertainty is eliminated—and all cooking is done better and quicker with a Butler Range. They are built for a lifetime of active service—The castings are heavy and perfect, the construction is simple and strong, the firebox is large, the oven is unusually roomy and our original patent flue construction insures an even heat to both the oven and top of range so that the back may be utilized for cooking with as good results as directly over firebox.

**If we have no salesroom or representatives in your vicinity
write us for catalog and easy payment plan**

Over one hundred thousand satisfied users in the United States and Canada testify that for perfection of results the Butler Ranges are absolutely the best.

THE STRONGMAN & RICHARDSON COMPANY
Boston San Francisco Chicago

12-Pt. Twin Buffalo Border No. 6. 54 inches \$1.50

Body set in 12-Pt. National Roman

Men's Superior Clothing

The entire stock of the bankrupt firm of Smith, Son & Co., of Rochester, has been placed with us for immediate disposal. For the next two weeks

\$10.78

is the price of this line of Men's Suits. All this season's styles made to sell for \$20, \$22 and \$25

Burt & Low
Men's Outfitters
52 Main Street, Cleanton

Baked Beans and Brown Bread



Baked Beans
per quart
15c

Brown Bread
per loaf
5c and 10c

These delicious viands are to be found on the tables of nearly every family in New England each Sunday morning of the year. We deliver them fresh and hot from our ovens each Saturday night and early Sunday morning

Acme Home Bakery
Theophilus Rowley, Proprietor
1832 Swansea Street, Boston

'Phone, Main 659

12-Pt. Runion Border, 54 inches \$1.50. Bean Pot Ornament No. 6, 15c

THE H. C. HANSEN TYPE FOUNDRY

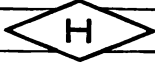

CONGRESS SERIES

Standard Line

48-Point

3A \$4.00 5a \$2.50 \$6.50

Hamilton Furniture in stock

42-Point

4A \$3.00 6a \$2.35 \$6.25

Hansen's Quads are without Nicks

18-Point

10A \$1.75 20a \$1.50 \$3.25

When the dews of night have fallen,
And the stars fond vigil keep,
When the cares of day are over,
And the world is hushed in sleep.

24-Point

6A \$2.00 12a \$1.50 \$3.50

The G. A. R. Encampment met at Washington in 1902

30-Point

5A \$2.25 12a \$2.00 \$4.25

Music for Grand Opera was composed by Rolfe

36-Point

4A \$3.00 8a \$2.25 \$5.25

Cylinder Press Chases in various sizes

<p>42-Point, Initial font, \$2.00 15 cents per letter</p> <p>A B C D E F G H I J K L M N O P Q R S T U V V W W X Y Z</p>	<p>18-Point Initial font, \$1.00 10 cents per letter</p> <p>24-Point Initial font, 1.25 10 cents per letter</p> <p>30-Point Initial font, 1.50 15 cents per letter</p> <p>36-Point Initial font, 1.75 15 cents per letter</p> <p>48-Point Initial font, 2.50 20 cents per letter</p> <p>Capitals put up in fonts of 30 letters each</p>
--	---

THE H. C. HANSEN TYPE FOUNDRY



STIPPLED GOTHIC

48-Point

3 A \$5.60

PRIZE IS WON

36-Point

4 A \$3.90

REFINED DISPLAY

STIPPLED GOTHIC

A STRONG LEGIBLE LETTER
OF PLEASING TONE

MADE BY

**THE H. C. HANSEN
TYPE FOUNDRY**

190-192 CONGRESS STREET, BOSTON, MASS.
NEW YORK BRANCH, 43 CENTRE STREET

24-Point

5 A \$2.50

THE FASCINATED CROWD

18-Point

8 A \$2.00

ENDORSE USE OF STIPPLED GOTHIC

6-Point Brass Rule No. 6 633. Per foot, \$0.40

THE H. C. HANSEN TYPE FOUNDRY



STIPPLED GOTHIC IN DISPLAY

\$ _____ Manchester, N. H. _____ 1907

MERCHANTS NATIONAL BANK

Pay to the order of _____ Dollars

and charge the same to our account.

HUB WHEEL COMPANY

No. _____ *President*

STIPPLED GOTHIC WITH CASLON O. S. NO. 2



A PRICE LIST OF PLAIN
AND FANCY KEROSENE

LAMPS

AND ACCESSORIES



ALADDIN ORNAMENT NO. 12. 15 CTS.
18-INCH FONT. \$1.50

RHEY LAMP CO.
PITTSBURGH, PA.

STIPPLED GOTHIC WITH HANSEN O. S. NO. 40



HANSEN'S IMPROVED
MITERING
MACHINE

Miters any angle accurately
and in much less time than
any other, therefore it saves
the printer from continually
wasting material and enables
him to do much better work

PRICE, \$18.50

ALEPPO ORNAMENT NO. 7
15 CTS.



THE H. C. HANSEN
TYPE FOUNDRY

190-192 CONGRESS ST., BOSTON

STIPPLED GOTHIC WITH CRAWFORD

THE H. C. HANSEN TYPE FOUNDRY



The Tokio Series



STANDARD LINE

All Hansen Type cast from Superior Copper Alloy Metal

48-Point

3A \$4.50 5a \$3.00 \$7.50

TEA MERCHANT Finest Oriental Blend

<p>CONCERT 8 TO 9 DANCING 9 TO 2</p>	<p>TOWN HALL, TUESDAY EVENING, FEBRUARY THE FOURTH, NINETEEN HUNDRED AND TEN</p>
<h2>Annual Concert and Ball</h2>	
<p>TICKETS Admitting Gentleman and Two Ladies, \$2.00</p> 	<p style="text-align: center;">Bingville Military Academy</p> 

6-Pt. Twin Buffalo Border No. 7, 60 inches, \$1.50

Tokio in combination with Stratford

Printers' Joy No. 15. Each, \$0.15

36-Point

4A \$3.00 6a \$2.00 \$5.00

TOURING IN DENMARK Sixteen Automobiles Wrecked

24-Point

6A \$2.00 10a \$1.50 \$3.50

GATHERING OF COLLEGE STUDENTS Discussing the great industrial questions today

THE H. C. HANSEN TYPE FOUNDRY



The Tokio Series In Display

STANDARD LINE

Style..... Width..... Toe..... Size.....	<h2>The Alpha Shoe</h2> <p>“Special” \$5.00</p>
---	---

12-Pt. Border No. 508. 54 inches, #1.50



An Oriental Tour



1907

Ornament No. 2. Set of four, \$0.40

“Lion Brand” Candy

PURE AND
WHOLESOME



Aleppo Orn. No. 4. \$0.25

Set with Hansen's Beveled Quads

The Tokio Series

- Is a strong and rugged letter for display
- headings in advertisements, for labels
- and work of a similar character. It will
- attract attention by its individuality, and
- should be considered where such effects
- are desired

Hansen's Spear Indicators



Commonwealth Series

Standard Line

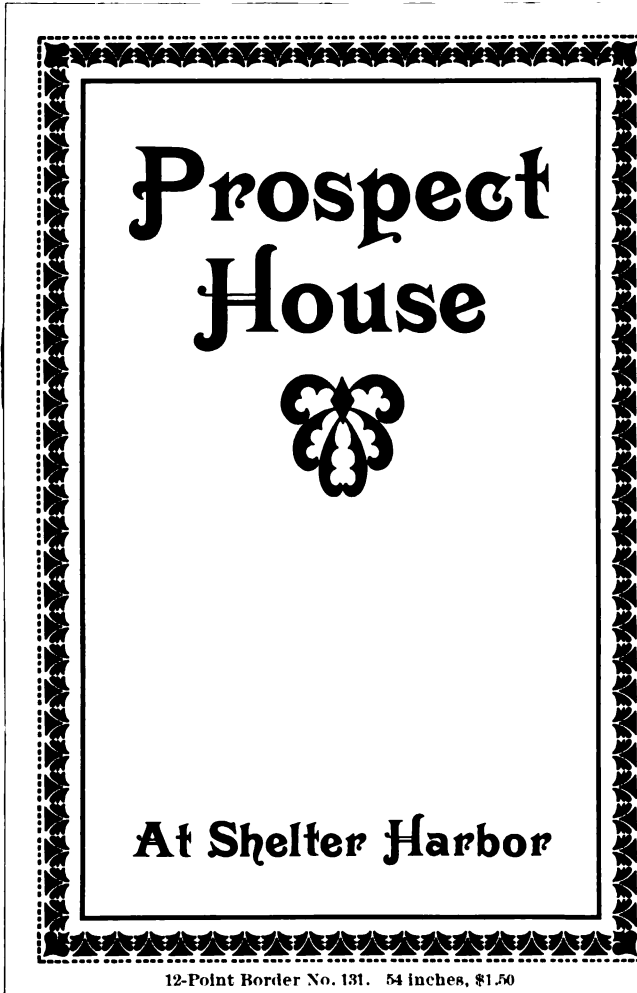

18-Point 8A \$1.50 20a \$1.75 \$3.25

**Type Engraved and Cast
from extra tough metal 5
Gauge made of solid brass**

24-Point 6A \$1.70 12a \$1.80 \$3.50

**Original Brass Rules
Designed by Hansen**

36-Point 5A \$2.30 8a \$2.10 \$5.00

**Great Anxiety
no bad results**

42-Point 4A \$3.50 6a \$2.50 \$6.00

**High Values
Waltham lot**

48-Point

3A \$3.30 7a \$3.70 \$7.00

**The Dust Proof Cabinet
Clean Type for Printer**

54-Point

3A \$4.65 4a \$2.60 \$7.25

Fat Man is in trouble

THE H. C. HANSEN TYPE FOUNDRY



WINCHENDON

All Hansen Type cast from Superior Copper Alloy Metal

48-Point

3A 5a \$7.50

Caps \$4.30 l.c. \$3.20

WOOD FURNITURE Hamilton Make 25

36-Point

4A 7a \$5.00

Caps \$2.50 l.c. \$2.50

BRIGHT IDEAS Useful Inventions

10-Point

16A 32a \$2.50

Caps \$1.20 l.c. \$1.30

**THE PRINTERS OF TODAY
All Need Hansen's Devices 7**

12-Point

12A 24a \$2.75

Caps \$1.30 l.c. \$1.45

**RESULT ATTAINED
By Constant Study 6**

30-Point

5A 10a \$4.25

Caps \$2.25 l.c. \$2.00

CHOOSE THE PLAINER TYPES FOR They Are Getting More Popular. \$3.75

Chandler & Price

JOB PRESSES

Are carried in stock and for sale by the H. C. Hansen Type Foundry. Thousands of friends have been won for this press because the rule "It is better to detect than to have to correct" has been rigidly observed.



Unrivalled

12-Point l'neada Border. 54 inches. \$1.50

24-Point

7A 14a \$3.50

Caps \$1.65 l.c. \$1.85

**THE OLD BAY STATE
Sends Armed Militia 34**

18-Point

10A 20a \$3.25

Caps \$1.50 l.c. \$1.75

**SOLDIERS DRILL DAILY
Bugler Blows Mess Call 458**

14-Point

12A 24a \$3.00

Caps \$1.35 l.c. \$1.65

**REMARKABLE VICTORY WON
By Troops from Massachusetts 1**

8-Point

18A 36a \$2.25

Caps \$1.00 l.c. \$1.25

**FOR THE BEST RESULTS USE HANSEN TYPE
It has won recognized merit for wearing qualities 8**

6-Point

20A 40a \$2.00

Caps \$0.90 l.c. \$1.10

**PLAIN AND BOLD LETTERS ARE COMING TO THE FRONT
Because of its legibility the Winchendon has a commercial 13**

THE H. C. HANSEN TYPE FOUNDRY



HOWLAND

48-Point

4A 8a \$6.25

Caps \$3.00 l.c. \$3.25

ENGRAVINGS From Catalogues

**GREAT
SHOE
SALE**

FOR MEN
and BOYS



\$1.87

Buys any shoe in this lot.
There are many \$3.50 and
\$5.00 values. This sale is
for one week only.

**MORRIGOLD
SHOE COMPANY
NEW YORK**

36-Point

5A 10a \$4.50

Caps \$2.00 l.c. \$2.50

THROUGH to New York

30-Point

6A 12a \$4.00

Caps \$1.80 l.c. \$2.20

MORE WARSHIPS COMING To Protect our Commerce 5

24-Point

8A 16a \$3.50

Caps \$1.80 l.c. \$1.90

SUPERB LETTER FOR PRINTERS Cases full of Howland in all sizes

18-Point

14A 28a \$3.25

Caps \$1.45 l.c. \$1.80

REQUIREMENTS OF A CONDENSED TYPE 123 More exacting than those of the extended faces

12-Point

18A 36a \$2.75

Caps \$1.25 l.c. \$1.50

WE HEREWITH SHOW THE HOWLAND IN TEN SIZES Cast from hard and tough metal and warranted to suit 9

10-Point

21A 42a \$2.50

Caps \$1.15 l.c. \$1.35

HANSEN'S COMPLETE TYPE MEASURES ARE IN USE DAILY 78 They are made of German Silver, and may also be used as dividers

8-Point

23A 46a \$2.25 Caps \$1.00 l.c. \$1.25

6-Point

24A 48a \$2.00 Caps \$0.95 l.c. \$1.05

BRASS RULE IN MANY DESIGNS 569 | NEW BEVELED QUADS AND QUOTATIONS May be found at Hansen's, Congress St | Make Angular Typography very easy 4560

*42-Point

5A 9a \$5.25

Caps \$2.75 l.c. \$2.50

Second Baseman's SACRIFICE HIT 34

*Same size face as 36-Point.

THE H. C. HANSEN TYPE FOUNDRY

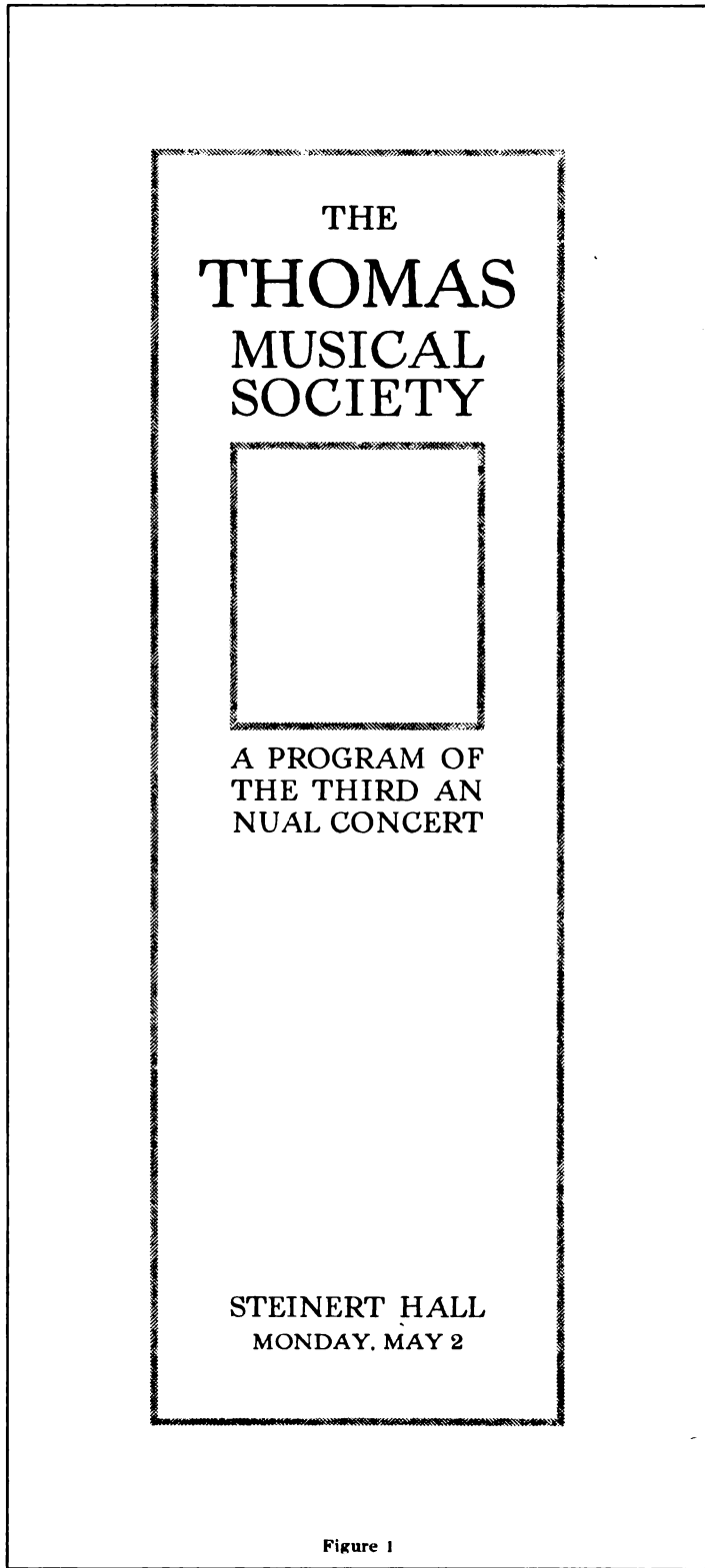

Figure 1

Figure 1
 Display set in Puritan
 Aladdin Ornament No. 4, 20c
 12-Pt. University Border, 54 in. \$1.50
 3-Pt. Half-tone Brass Rule No. 655

Figure 2
 Display set in Caslon Full Face
 12-Pt. Uneeda Border, 54 in. \$1.50

The H. C. Hansen Type Foundry
 190-192 Congress Street, Boston
 43 Centre Street, New York

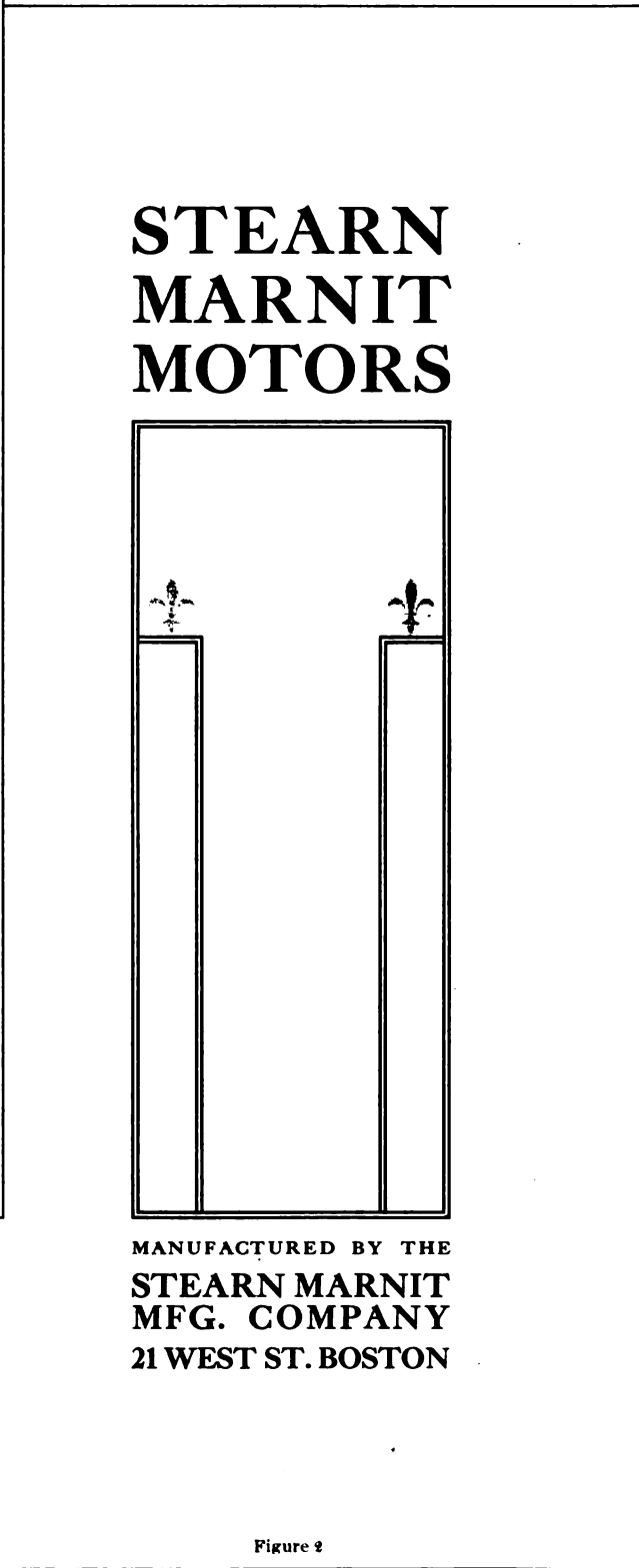

Figure 2

MANUFACTURED BY THE
STEARN MARNIT
MFG. COMPANY
 21 WEST ST. BOSTON

FINE RUGS

COMPLETE CATALOGUE AND PRICE LIST
OF THE MOST ARTISTIC AND BEAUTIFUL
PRODUCTS OF ORIENTAL MANUFACTURE

TO WHICH IS ADDED A SUPERB COLLECTION OF
OUR JUSTLY CELEBRATED "AXMINSTER" CARPETS

1878



1909

THE AXMINSTER CARPET CO.

1247-49 WASHINGTON AVENUE, PHILADELPHIA, PA.

BRANCH AT NEWPORT, RHODE ISLAND



STEEL PLATE GOTHIC

6-Point No. 1 35A \$1.00

THIS GOTHIC IS DESIGNED FOR THE PRODUCTION OF THE HIGHEST GRADES OF STATIONERY AND OFFICE WORK. IT IS THE TYPE PAR EXCELLENCE FOR NEAT CARDS AND INVITATIONS. CAST IN SEVEN FINELY GRADED SIZES FROM HANSEN'S SUPERIOR COPPER-ALLOY 38

6-Point No. 2 30A \$1.00

LET US SEND YOU A HANSEN COMPLETE UPRIGHT MITERER ON TRIAL. MORE OF THESE MACHINES ARE SOLD THAN ALL OTHER MAKES COMBINED. NO LINES TO GUESS AT. EVERY ANGLE SET BY A PIN WHICH INSURES ABSOLUTE ACCURACY 4

6-Point No. 3 22A \$1.00

HANSEN'S STEEL CUTTING DIES CAN BE USED ON ANY ORDINARY PLATEN PRESS AND ENABLES THE PRINTER TO PRODUCE MANY UNIQUE NOVELTIES IN CUT-OUTS FOR BOOKLETS, ETC. REASONABLE 231

6-Point No. 4 20A \$1.00

THERE IS WIDE SPREAD BELIEF THAT TYPOGRAPHY WAS, IN ALL ITS DETAILS, A PURELY ORIGINAL INVENTION. A POPULAR VERSION SAYS IT WAS THE RESULT OF AN ACCIDENT

12-Point No. 5 23A \$1.50

ALL TYPES DISPLAYED BY HANSEN MANUFACTURED IN THIS FOUNDRY FACES IN THIS BOOK ARE \$987.65

12-Point No. 6 22A \$1.50

THE LETTER OF INDIVIDUALITY FOR THE PRODUCTION OF HIGH GRADE TYPOGRAPHICAL WORK

12-Point No. 7 15A \$1.50

GRACEFUL OUTLINE OF STEEL PLATE GOTHIC PLEASES PURCHASERS

DR. ELSA RICHARDSON

GRADUATE PROF. HAMILTON'S INSTITUTE, LONDON
MEDICAL GYMNAST AND MASSEUSE

68 OAKLAND TERRACE

THIRD CELEBRATION AND ANNUAL DINNER

GIVEN UNDER THE
AUSPICES OF

THE LOTUS
ASSOCIATES

MENU

OYSTER COCKTAIL

BISQUE OF LOBSTER, CAMBRIDGE

QUEEN OLIVES

MIXED PICKLES



BROILED SHAD, AU BEURRE

BOILED POTATOES



ROAST SIRLOIN OF BEEF

TURKEY, CRANBERRY SAUCE

SALAD OF FRESH FRUITS



PLUM PUDDING, BRANDY SAUCE

ORANGE GLACE

ASSORTED CAKE



ROQUEFORT CHEESE

DEMI TASSE

MRS. F. H. FARRINGTON, JR.

45 BEACON CHAMBERS
BROOKLINE

THE H. C. HANSEN TYPE FOUNDRY



The Lafayette Text

Standard Line

36-Point

4A \$2.60 8a \$2.40 \$5.00

English Manuscripts Published by Caslon

30-Point

5A \$2.05 11a \$2.25 \$4.30

A Useful Series for High Class Commercial Work 2

24-Point

5A \$1.65 12a \$1.85 \$3.50

Annual Graduating Exercises of the Harvard College next month

A Psalm of Life

Tell me not, in mournful numbers,
Life is but an empty dream!
For the soul is dead that slumbers,
And things are not what they seem.

Life is real! Life is earnest!
And the grave is not the goal:
"Dust thou art, to dust returnest,"
Was not spoken of the soul.

Not enjoyment, and not sorrow,
Is our destined end or way;
But to act, that each tomorrow
Find us farther than today.

Art is long and time is fleeting,
And our hearts, though stout and brave,
Still, like muffled drums, are beating
Funeral marches to the grave.

Let us, then, be up and doing,
With a heart for any fate;
Still achieving, still pursuing,
Learn to labor and to wait.

—Longfellow.

6-Point 16A \$0.85 50a \$1.15 \$2.00

Early Printers

Continued

Many of the early printers disregarded the even spacing of their lines. Take the famous "Bible of 36 lines," which is believed to have been printed in 1459 or 1460. The type was large, about 22-point, the measure about 20 1-2 picas, and it would have been difficult to space out the lines uniformly. The printer never attempted it but almost uniformly put his surplus spaces at the end. As words were divided with little regard to the syllables, the lines in solid matter often came out pretty evenly though there was an alarming number of hyphens strung along the right-hand margin. The printing of Joseph Lehnhardt in Mentz of about 1455, as well as others of that period, shows evidence of a desire to make lines end somewhere near uniformly, but there is no exactness about their work. Albert Pfeister's printing of 1462 was sometimes spaced and sometimes unspaced.

10-Point

15A \$1.10 4a \$1.40 \$2.50

18-Point

8A \$1.40 22a \$1.85 \$3.25

The craft of letter designers is one of wide influence, for upon them rests, in a large degree, the responsibility of

14-Point

10A \$1.25 38a \$1.75 \$3.00

Cultivating the public taste in the form of Letters. The evolution of the Roman alphabet is an interesting study. Having for its students the scribes, sculptors and engravers of

12-Point

13A \$1.25 37a \$1.50 \$2.75

Was invented, brought to its service artists of renown who were pleased to study every individual character. While the art of printing tends to crystalize the form of letters, the genius of the designer rings

8-Point

16A \$1.00 48a \$1.25 \$2.25

And curves. He has extended, condensed, inclined and ornamented; he has exaggerated what was at first tolerated as eccentricities until they became monstrosities; until now he who is endowed with true artistic feeling goes back to early models, such as the type founders of the sixteenth century produced. Thus the printer of 20

THE H. C. HANSEN TYPE FOUNDRY

Lafayette Text
in Display

William Montgomery
Born June 1 Weight, 9 pounds
Mr. & Mrs. William Walsh
No. 8 Lafayette Road
Roxborough
SET WITH HANSEN'S BEVELED QUADS

R. S. H. H.

Alter Ego Minstrels

The Annual Minstrel Show and Dance of the Alter Ego Club will be held at the Club House grounds on Brookline Street Monday evening, February the tenth. As in previous years, the entertainment will be followed by a Banquet to which all the members with their lady guests are cordially invited



Doors open at 7 o'clock

SYLPH INITIAL

PRINTERS' JOY NO. 9. 10C

Success

HE HAS achieved success who has lived well, laughed often and loved much; who has gained the respect of intelligent men and the love of little children; who has filled his niche and accomplished his task; who has left the world better than he found it, whether by an improved poppy, a perfect poem, or a rescued soul; who has never lacked appreciation of the Earth's beauty or failed to express it; who has always looked for the best in others and given the best he had; whose life was an inspiration; whose memory is a benediction

A. J. Stanley

8-PT. BORDER NO. 502. 80-INCH FONT, \$1.50

Old Devonshire
Trust Company

Twenty-third Annual Report of
the Board of Directors



August, 1908

No. 238 Boylston Street
Los Angeles, California

THE H. C. HANSEN TYPE FOUNDRY



The Thomson-Dix Engraving Company
 Engraving in all its Branches. Originators of the
 Quadri-tone Process of Halftone Plates. Etchings
 on Zinc. Work Guaranteed to be of Highest Grade
 Number 453 to 461 Stratford Avenue, Poughkeepsie, New York

12-PT. BORDER NO. 134. 34-INCH FONT. \$1.50

Return in five days to

Thomson-Dix Engraving Company
 Poughkeepsie New York

Established 1872 Phone, 2738 Main

The H. C. Hansen Type Foundry
 Manufacturers of Type, Brass Rule
 and Printers' Supplies

190-192 Congress Street 42 Centre Street
 Boston New York

Miss Gertrude Whitcomb
 Teacher of Elocution

56 Studio Chambers
 Boston



The Fleur-de-lis Society

Will celebrate its fifteenth Anniversary
 and the completion of its new
 Club House with a

Reception and Dance

To be held on Thursday evening, March the second
 Nineteen hundred and seven

An excellent musical program will be given followed
 by a dance and banquet. Each member
 may invite two guests

Carriages at three o'clock

A Dramatic Recital

Will be given by Signor Mascagnio on
 Wednesday afternoon July the sixteenth
 in the Oratory Building. Selections
 from Shakespeare's Othello is featured



Tickets Two Dollars Eight o'clock

All Hansen Type cast from Superior Copper Alloy Metal

THE H. C. HANSEN TYPE FOUNDRY



Mrs. Evelyn F. Hollingsworth

announces the marriage of her daughter

Alice May

to

Mr. Henry Ray Stockton

on Wednesday afternoon, June the twenty-eighth

hundred and five

three o'clock

achusetts

Card Text

8-Pt. 14A 40a \$2.25 Caps \$1.00 l.c. \$1.25

Wedding Ceremonies take place usually in the month of June, because it is the month of roses
1234567890

10-Pt. 12A 35a \$2.50 Caps \$1.15 l.c. \$1.36

Invitations are now being extended to all members of the Dignified 12

12-Pt. 12A 32a \$2.75 Caps \$1.25 l.c. \$1.50

Guests arriving daily at Hotel Grand situated at 58 Ocean Avenue

18-Pt. 6A 18a \$3.25 Caps \$1.50 l.c. \$1.75

Card Text is a proper type for announcements G

14 and 24-Point in Preparation

At Home
Wednesdays after August the tenth
568 Lakeside Avenue
Newport

SET WITH HANSEN'S BEVELED QUADS AND QUOTATIONS



The Thomson-Dix Engraving Company
 Engraving in all its Branches. Originators of the
 Quadri-tone Process of Halftone Plates. Etchings
 on Zinc. Work Guaranteed to be of Highest Grade
 Number 453 to 461 Stratford Avenue, Poughkeepsie, New York

12-PT. BORDER NO. 134. 54-INCH FONT. \$1.50

Return in five days to

**Thomson-Dix Engraving
 Company**

Poughkeepsie
 New York

Established 1872 Phone. 2738 Main

The H. C. Hansen Type Foundry
 Manufacturers of Type, Brass Rule
 and Printers' Supplies

190-192 Congress Street 43 Centre Street
 Boston New York

Miss Gertrude Whitcomb
 Teacher of Elocution

56 Studio Chambers
 Boston



The Fleur-de-lis Society

Will celebrate its fifteenth Anniversary
 and the completion of its new
 Club House with a

Reception and Dance

To be held on Thursday evening, March the second
 Nineteen hundred and seven

An excellent musical program will be given followed
 by a dance and banquet. Each member
 may invite two guests

Carriages at three o'clock

A Dramatic Recital

Will be given by Signor Mascagnio on
 Wednesday afternoon July the sixteenth
 in the Oratory Building. Selections
 from Shakespeare's Othello is featured



Tickets Two Dollars Eight o'clock

All Hansen Type cast from Superior Copper Alloy Metal

THE H. C. HANSEN TYPE FOUNDRY



Mrs. Evelyn F. Hollingsworth

announces the marriage of her daughter

Alice May

to

Mr. Henry Ray Stockton

on Wednesday afternoon, June the twenty-eighth

hundred and five

three o'clock

Massachusetts

Card Text

8-Pt. 14A 40a \$2.25 Caps \$1.00 l.c. \$1.25

Wedding Ceremonies take place usually in the month of June, because it is the month of roses
1234567890

10-Pt. 12A 36a \$2.50 Caps \$1.15 l.c. \$1.35

Invitations are now being extended to all members of the Dignified 12

12-Pt. 12A 32a \$2.75 Caps \$1.25 l.c. \$1.50

Guests arriving daily at Hotel Grand situated at 38 Ocean Avenue

18-Pt. 6A 18a \$3.25 Caps \$1.50 l.c. \$1.75

Card Text is a proper type for announcements G

14 and 24-Point in Preparation

At Home
Wednesdays after August the tenth
368 Lakeside Avenue
Newport

SET WITH HANSEN'S BEVELED QUADS AND QUOTATIONS



CARD GOTHIC

32A 6-Pt. No. 10 \$1.00
NEAT TYPOGRAPHICAL EFFECTS FOR ALL FORMS OF OFFICE STATIONERY CAN BE PRODUCED FROM THIS SERIES OF TYPE ADMIRABLY FITTED ALSO FOR SOCIETY PRINTING OF THE 400 WHICH TENDS TO RAISE THE PROFITS OF THE JOB PRINTER

25A 6-Pt. No. 11 \$1.00
MANY NEW DEVICES CONSTANTLY PERFECTED BY THIS FOUNDRY HAVE GREATLY AIDED PRINTERS TO DO INTRICATE WORK WITH EASE, THEREFORE ENABLING THEM TO PRODUCE A JOB WITH LESS

14A 8-Pt. No. 14 \$1.25
HANDSOME AND POPULAR LETTERS CAST BY THE H. C. HANSEN TYPE FOUNDRY ARE HERE NOTED 2

13A 10-Pt. No. 15 \$1.50
CARD GOTHIC IS ADMIRABLY ADAPTED FOR PRINTING WHERE NEATNESS IS A FEATURE

10A 12-Pt. No. 16 \$1.50
PROFESSIONAL MEN WITH SALARIES BANKS AND OTHER INSTITUTIONS 7

18A 6-Pt. No. 12 \$1.00
BUYERS OF PRINTING DEMAND THIS DIGNIFIED LETTER, FOR THEIR IDEA OF SIMPLICITY IS CORRECT AND NO

16A 8-Pt. No. 13 \$1.25
THE OLD GRANITE BANK IS STILL OPEN FOR BUSINESS AT THE SAME OLD STAND 8

CARD GOTHIC IS A PERFECT TYPE FOR ALL FORMS OF STATIONERY

ESTABLISHED 1894 TELEPHONE 26 SPRING

BURKET & WHITNEY
MANUFACTURERS OF
FIRE-PROOF SAFES
AND VAULTS

28 SUDBURY STREET DETROIT, MICH.

NOTE HOW CLEAR CUT ARE THE SMALLER SIZES

FINE BOATING AND BATHING

SQUIRREL INN
SQUIRREL ISLAND
MAINE
K. H. RICHARDS, PROP.

NICE LIGHT AIRY ROOMS



**CARD GOTHIC
No. 2**

30A 6-Pt. No. 2 A \$1.00

CARD GOTHIC MADE BY H. C. HANSEN TYPE
FOUNDRY, 160 CONGRESS STREET, WHERE
YOU WILL RECEIVE COURTEOUS TREATMENT
AND QUALITY OF MATERIAL THE VERY BEST

24A 6-Pt. No. 2 B \$1.00

MUCH PRAISE ELICITED FROM ALL
PARTS OF THE COUNTRY GIVES US
BUT A FAINT IDEA OF THE TRULY
WONDERFUL RHETORICAL POWER I

18A 6-Pt. No. 2 C \$1.00

CARDS PRINTED NEATLY ON
MODERN PRESSES RUNNING
AT A SPEED RANGING FROM
TWO THOUSAND TO 2568 AN

16A 6-Pt. No. 2 D \$1.00

ANY ARTICLES OBTAINED
FOR PRINTING FROM THE
HANSEN TYPE FOUNDRY
WILL GIVE SATISFACTION

18A 12-Pt. No. 2 A \$1.50

COMPETITION IN THE
PRINTING TRADE ON
A BASIS OF VALUE 4

16A 12-Pt. No. 2 B \$1.50

AN ORDER BLANK
IS ENCLOSED FOR
CONVENIENCE 28

14A 12-Pt. No. 2 C \$1.50

SUMMER GIVES
ONE A GLIMPSE
OF NATURE IN 3

12A 12-Pt. No. 2 D \$1.50

AUTOMOBILE
RACE UP THE
MOUNTAIN 15

FLOWER EXHIBIT

OF THE

**MASSACHUSETTS
PANSY SOCIETY**



ANNOUNCEMENT

WE TAKE PLEASURE IN PRESENTING TO THE
PRINTING TRADE THIS ATTRACTIVE SERIES
OF TYPE, CARD GOTHIC No. 2, PERFECT FOR
BUSINESS OR SOCIETY PRINTING, PLEASING
TO THE EYE AND NOTED FOR CLEARNESS.

THE H. C. HANSEN TYPE FOUNDRY
SET WITH HANSEN'S BEVELED QUADS AND QUOTATIONS

HELD IN

**MECHANICS BUILDING
BOSTON**

**TUESDAY AND WEDNESDAY
AFTERNOON AND EVENING
AUGUST FOURTH AND FIFTH**

**MEMBERS REQUESTED
TO WEAR A RED PANSY**

THE H. C. HANSEN TYPE FOUNDRY

CARD GOTHIC No. 3

35A 6-Pt. No. 3 A \$1.00
CARDS, INVITATIONS AND EVERY CLASS OF FINE PRINTING IN WHICH PLAIN, NEAT TYPE SHOULD BE USED. CARD GOTHIC 3

30A 6-Pt. No. 3 B \$1.00
MANY TIMES ARE PRINTERS UNDECIDED AS TO WHAT TYPE WOULD BE SUITABLE FOR CERTAIN LINES OF WORK 287

26A 6-Pt. No. 3 C \$1.00
PRINTING TYPES AND MATERIAL FOR COMPLETE EQUIPMENTS FURNISHED BY HANSEN, 190 AND 192

20A 6-Pt. No. 3 D \$1.00
THE ANNUAL PICNIC OF THE FIRST ROYAL BUMPERS HELD IN CALEDONIAN GROVE 36

20A 8-Pt. No. 3 E \$1.25
EXCELLENT JUDGMENT EXHIBITED IN SELECTING THIS ADMIRABLE LETTER

18A 8-Pt. No. 3 F \$1.25
BUSINESS RELATIONS BETWEEN EUROPE AND THIS COUNTRY 75

19A 10-Pt. No. 3 G \$1.50
TYPOGRAPHICAL CONTESTS SHOWING 187 TYPE DESIGNS

15A 12-Pt. No. 3 H \$1.50
ENERGETIC MEN FROM BOSTON AND CHICAGO

12A 12-Pt. No. 3 I \$1.50
RECITAL BY FAMED MUSICIANS FROM 38

10A 14-Pt. No. 3 J \$1.85
GREAT DEMAND FOR MAGAZINES

8A 18-Pt. No. 3 K \$2.00
OUTING CAMP IN THE SHADE

6A 24-Pt. No. 3 L \$2.50
WESTFIELD SEMINARY 1

THIS ATTRACTIVE SERIES OF TYPE IS CAST IN TWELVE SIZES AND WHEN ONCE USED WILL BE APPRECIATED

WRIGHT'S TAVERN**CONCORD, MASSACHUSETTS**

Printers' Joy No. 23, 40c

A LITTLE BOOKLET CONCERNING THIS HISTORIC HOSTELRY WHICH SHOULD BE INTERESTING TO EVERY VISITOR

HIGH ART BRASS RULE NO. 6 689. PER FOOT, \$0.40. SEE PAGE 228

CHARLES P. DAVENPORT

762 SUDBURY STREET

REPRESENTING
ROYAL INSURANCE COMPANY
NEW YORK

BOSTON

THE H. C. HANSEN TYPE FOUNDRY



THE YULETIDE BANQUET

OF THE
GRADUATING CLASS
GLENDALE
ACADEMY

THURSDAY EVENING, DECEMBER THIRTY
NINETEEN HUNDRED AND FIVE



HELD UNDER THE AUSPICES OF
THE ALUMNI OF THE ACADEMY

HOTEL PRINCESS
GLENDALE

HIGH ART BRASS RULE NO. 8 693. PER FOOT, \$0.40. SEE PAGE 228.

CARD GOTHIC No. 3
IN DISPLAY

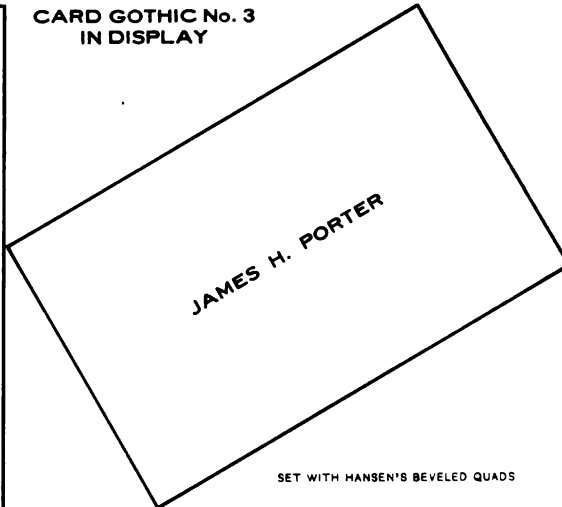

SET WITH HANSEN'S BEVELED QUADS

MENU

OYSTERS

ES OLIVES CELERY

MONGOLE SOUP

FILETS OF SOLE DE VIN BLANC

POTATOES HOLLANDAISE

TENDERLOIN OF BEEF, MUSHROOM SAUCE

ELS SPROUTS POTATOES DUCHESSE

ROMAN PUNCH

ROAST BREAST OF BLACK DUCK

FRIED HOMINY CURRANT JELLY

ROMAN SALAD

NEAPOLITAN ICE CREAM ASSORTED CAKES

COFFEE



ANNUAL BANQUET
GLENDALE ACADEMY
CLASS OF 1905

WEDNESDAY EVENING, JUNE THE SIXTH
HOTEL PRINCESS

ADMIT _____

CARD ROMAN

35A 6-Pt. No. 32 \$1.00

A DISTINGUISHING FEATURE OF THIS SERIES OF TYPE LIES IN ITS ADAPTABILITY FOR ALMOST ANY KIND OF WORK, THEREFORE THE WIDE RANGE OF USEFULNESS WHICH IT COVERS GIVES IT A GREATER COMMERCIAL VALUE TO PRINTERS THAN MANY OTHER TYPE FACES 17

24A 6-Pt. No. 33 \$1.00

AN EXAMINATION OF THE VARIOUS TYPE FACES SHOWN IN THIS SPECIMEN BOOK WILL REVEAL TO PRINTERS AN ARRAY OF USEFUL LETTERS OF PLEASING DESIGN, WHICH CAN BE USED EVERY

18A 6-Pt. No. 34 \$1.00

IT IS PROVED BEYOND ALL DOUBT THAT HANSEN'S COMPLETE MITERER IS AWAY AHEAD OF ANY OTHER MACHINE MADE FOR MITERING BRASS RULES, AND IS 38

18A 8-Pt. No. 35 \$1.25

CARD ROMAN CAN BE USED ON ANY FORM OF STATIONERY, IS ALSO A CORRECT TYPE FOR 46

15A 10-Pt. No. 36 \$1.50

RESEMBLES ENGRAVED WORK AND LOOKS NEAT WHEN NICELY PRINTED

12A 12-Pt. No. 37 \$1.60

RECENT SHIPMENT PLATEN PRESSES 7

8A 18-Pt. No. 38 \$2.10

A REQUIRED LINE FOUND

6A 24-Pt. No. 39 \$2.75

PLEASED BUYER 12

**STOCKS
BONDS**

AND ALL KINDS OF

**INVESTMENT
SECURITIES**

—
A DETAILED LIST OF INVESTMENTS
ISSUED WEEKLY
—

FRANK S. KNOWLTON

BANKER AND BROKER

TRIBUNE BUILDING, 28 HIGH ST.

CHICAGO

MISS HARRIET BRANDON

ANNOUNCES HER OPENING OF
THE LATEST STYLES IN

MILLINERY

TO TAKE PLACE AT HER PARLORS IN THE
WINDSOR BUILDING, 35 SPRING ST.

ON TUESDAY AFTERNOON

MAY THE FIFTH

YOU ARE REQUESTED TO ATTEND

Hansen Vertical Script

24-Point

5A \$2.00 15a \$2.50 \$4.50

Spring Sales are Patronized by the multitude
Unmistakable Bargains on each counter 48¢

12-Point

10A \$1.25 35a \$2.00 \$3.25

Vertical Script is Universally
Popular Among the Students of the
Leading Colleges in America
Endorsed by Instructors

18-Point

8A \$1.50 25a \$2.50 \$4.00

Hansen Vertical Script
Modern Penmanship
Graceful Delicate Lines

You and your friends are invited to
inspect an assortment of choice
and exclusive designs in

Millinery

These are the advance fall styles of
the most famous Parisian designers
and were personally selected during
my trip abroad with a view to
pleasing critical patronage

30-Point

3A \$1.75 10a \$3.00 \$4.75

Labor-saving devices bring profit
Growth is Pleasing to Contemplate

36-Point

3A \$2.50 8a \$3.50 \$6.00

Vertical Script Most Legible
To purchase wisely brings \$98

THE H. C. HANSEN TYPE FOUNDRY

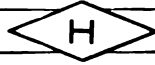

Newton Script

12-Point 9A 36a \$3.75 Caps \$1.50 l.c. \$2.25

*The Ceremony of Initiation
Conferring Degrees upon 148 Royal Visitors*

18-Point 8A 28a \$5.00 Caps \$2.15 l.c. \$2.85

*Wedding Announcements
Newton Script the proper type 2*

24-Point 5A 15a \$5.00 Caps \$2.25 l.c. \$2.75

*Unique Contract
Printed in 8 Languages*

30-Point 5A 15a \$6.25 Caps \$3.00 l.c. \$3.25

*At Home Cards
For Thursdays only*

*The Amazon Outing Club
invites you and lady friend
to be present at their
Annual Picnic and Dancing Party
on Thursday afternoon, July the sixth
nineteen hundred and five
Canobie Lake*

SET WITH HANSEN'S BEVELED QUADS AND QUOTATIONS

Mrs. James Ringold
requests your presence
at the marriage of her daughter
Grace Sibyl
to
Mr. Henry Powers Cutter
on Wednesday evening, June the eighth
one thousand nine hundred and five
at half after eight o'clock
Standish Avenue
Glenmere

SHOWING 24 AND 30-POINT SIZES OF NEWTON SCRIPT

ä å à á ê è é ö ô û ù ñ ç Š Š Œ Œ

THE ABOVE ACCENTS ARE MADE IN ALL SIZES OF NEWTON SCRIPT. SEE PAGE 43

THE H. C. HANSEN TYPE FOUNDRY



PLATE ROMAN

36A 6-Pt. No. 1 \$1.00
 MESSAGES TRANSMITTED BY WIRELESS TO ALL PARTS OF THE
 COUNTRY SHOWS EVIDENCE OF PROGRESSIVENESS AND ZEALOUS

27A 6-Pt. No. 2 \$1.00
 PROMPT METHODS IN BUSINESS WILL SURELY MERIT
 APPRECIATION FROM CUSTOMERS WHO LOOK FOR 36

22A 6-Pt. No. 3 \$1.00
 PLATE ROMAN FOR MERCANTILE PRINTING
 HAS PROVED ITS WORTH TO MANY PRINTERS

18A 6-Pt. No. 4 \$1.00
 BEFORE BUYING PRINTING MATERIAL
 CONSULT HANSEN AT 190 CONGRESS

22A 12-Pt. No. 5 \$1.50
 A VARIETY OF PLEASING STYLES
 IN TYPE, BORDERS, BRASS RULE

18A 12-Pt. No. 6 \$1.50
 SURPRISING RESULTS CAN BE
 OBTAINED FROM CONSTANT 5

14A 12-Pt. No. 7 \$1.50
 PERFECT REGISTER ON
 COLOR FORMS ALWAYS

12A 12-Pt. No. 8 \$1.50
**COMMENCEMENT AT
 BATES COLLEGE 25**

9A 18-Pt. No. 9 \$2.00
**ATHLETIC CLUB
 TOURNAMENT 18**

8A 18-Pt. No. 10 \$2.00
**LAW BLANKS
 AND BRIEFS 7**

6A 24-Pt. No. 11 \$2.50
**WITH THE
 COUNSEL 6**

TELEPHONE 29 BROWN

BOSTON, _____ 190

M

To **BUTLER & STEVENS, DR.**
 PUBLISHERS

TEXT BOOKS FOR SCHOOLS AND
 COLLEGES A SPECIAL FEATURE

MISS ETHEL MAY ADAMS
 ELOCUTIONIST

36 FRONT STREET

NEWPORT, N. H.

THE H. C. HANSEN TYPE FOUNDRY



THE HOUSE OF HANSEN
AN INDEPENDENT TYPE FOUNDRY. ESTABLISHED 1872

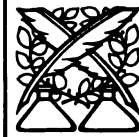

**ENGRAVERS
GOTHIC SERIES**

AN ATTRACTIVE SERIES OF TYPE
WHICH WILL GIVE THAT COPPER-
PLATE AND LITHOGRAPH EFFECT
SO DESIRABLE IN GOOD PRINTING



**THE H. C. HANSEN
TYPE FOUNDRY**

190-192 CONGRESS STREET, BOSTON
535-537 PEARL STREET, NEW YORK



DESIGNERS, MANUFACTURERS AND DISTRIBUTERS OF
THE VERY BEST FOR THE MAN WHO PRINTS

GRAY TONE BRASS RULE. BERKSHIRE ORNAMENT NO. 36

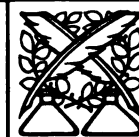

ENGRAVERS GOTHIC SERIES

FOR COPPER PLATE EFFECT

6-Point No. 1

37A \$1.00

THE WIDE RANGE OF USEFULNESS OF THIS ATTRACTIVE SERIES OF GOTHIC IS OBVIOUS AT A GLANCE. IT IS UNEXCELLED FOR CARDS, STATIONERY, INVITATIONS, AND THE LIKE. A DIVIDEND PRODUCER

6-Point No. 2

32A \$1.00

HANSEN'S PRODUCTS ARE BACKED BY OVER FORTY YEARS OF EXPERIENCE IN CATERING TO THE EXACTING REQUIREMENTS OF PRINTERS. AN INDEPENDENT TYPE FOUNDRY 2

6-Point No. 3

26A \$1.00

MACHINERY AND MATERIALS FOR REQUIREMENTS OF SPECIAL WORK MAY BE OBTAINED FROM THE H. C. HANSEN TYPE FOUNDRY, BOSTON, MASS. 174

6-Point No. 4

21A \$1.00

ATTRACTIVELY NEAT STATIONERY GIVES A GOOD IMPRESSION OF THE USER, AND IS A GREAT FACTOR TOWARD SUCCESS 4

12-Point No. 5

24A \$1.50

IF YOU DESIRE THE VERY BEST IN PRINTING OFFICE SUPPLIES, YOU WILL CALL ON HANSEN, BOSTON

12-Point No. 6

19A \$1.50

NICELY GRADED SERIES FOR COMMERCIAL PRINTING THAT WILL PLEASE CUSTOMERS 3

12-Point No. 7

16A \$1.50

GOOD EQUIPMENT WILL PROVE AN ECONOMY IN SAVING VALUABLE TIME

12-Point No. 8

13A \$1.50

EXPERT OPINION ON MODERN PRINTSHOP PUBLISHED IN BRIEF

18-Point No. 9

11A \$2.00

BUSY TIME IN THE PRINTING OFFICE PROFIT IS ACQUIRED BY INDUSTRY

18-Point No. 10

9A \$2.00

SHOW BEAUTIFUL SPECIMENS MERITORIOUS WORK OF FIRM

24-Point No. 11

7A \$2.50

HONEST MERCHANT PAYS BILL AND GETS DISCOUNT

24-Point No. 12

6A \$2.50

DESIRES HIGH GRADE PRINTING AT PRICE 15

THE H. C. HANSEN TYPE FOUNDRY

TELEPHONE

ROBERT HENRY BROWNE
ATTORNEY-AT-LAW

BROWNE BUILDING

NEW HAVEN

ENGRAVERS GOTHIC

FOR COPPER PLATE EFFECT

MILTON ENRIGHT RICHARDSON

PRESS CLUB

\$

HOLYOKE

19

REAL ESTATE SECURITIES CO.

422-428 MILLER BUILDING

RECEIVED OF _____

_____ DOLLARS

No. _____

_____ TREASURER

**THE
H. C. HANSEN
TYPE
FOUNDRY**
190-192 CONGRESS ST.
BOSTON

BRANCH AT
535-537 PEARL ST.
NEW YORK

ANNOUNCEMENT

MESSRS. RANSOME & NORTON

ANNOUNCE THE OPENING OF THEIR ELEGANT
NEW ROOMS WITH A COMPLETE AND
HANDSOME DISPLAY OF

LADIES' TAILORED GARMENTS
FOR FALL AND WINTER

FAR EXCEEDING THOSE OFFERED IN PAST
SEASONS. WE SHOULD BE PLEASED
TO RECEIVE A CALL FROM YOU

AN ATTRACTIVE SERIES

ENGRAVERS GOTHIC

FOR COPPER PLATE EFFECT

GEO. N. HILTON
JOHN D. LORD

CABLE ADDRESS
"HILO" DAYTON

HILTON-LORD COMPANY REAL ESTATE

HIGH GRADE PROPERTIES EXCLUSIVELY
107-8-9 NORTH BUILDING
DAYTON, O.

M. PAUL HIGGINS, PRESIDENT

MONTHLY STATEMENT

FRED H. WILLIS, MANAGER

HUDSON BRONZE COMPANY BRONZE CASTINGS

OFFICE AND FACTORY: 24 BOONE STREET

HUDSON, N. Y., _____ 19____

ACCOUNT OF _____

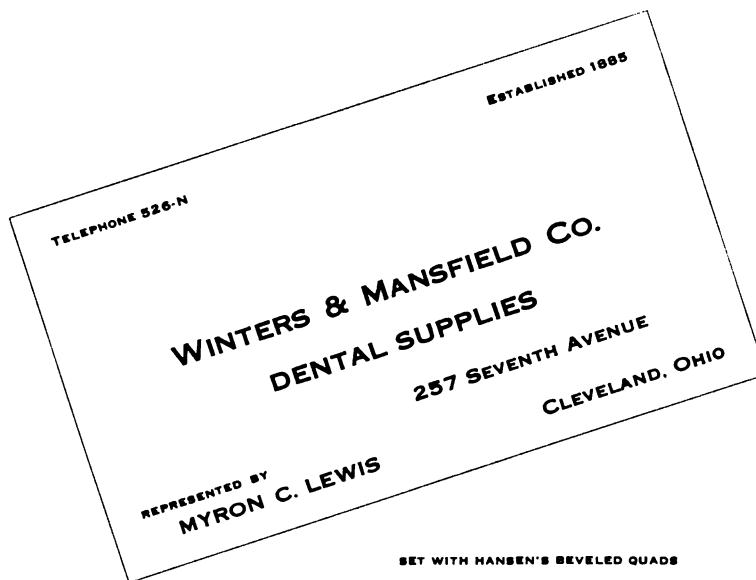

THE H. C. HANSEN TYPE FOUNDRY

GRAYTONE BRASS RULE: 8-PT. 768 AND 2-PT. 764

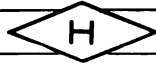

COPPERPLATE ROMAN

FOR CARD AND
GENERAL COMMERCIAL
PRINTING

H. J. LINCOLN, PRESIDENT

JOHN K. SHARPE, TREASURER

LINCOLN MANUFACTURING CO.

MAKERS OF
SURGICAL INSTRUMENTS

BOSTON, MASS.



THE H. C. HANSEN TYPE FOUNDRY

TYPE

190-192 CONGRESS STREET
BOSTON, MASS.

FONT SCHEMES AND PRICES

20A 8-Pt. No. 1 \$1.25

COMMERCIAL WORK
AS WELL AS FINE PROGRAMS
AND BUSINESS CARDS

15A 8-Pt. No. 2 \$1.25

PAY ON DEMAND
SIXTY-FOUR DOLLARS 64
TO MR. LENDUM

15A 10-Pt. No. 3 \$1.50

FORTUNE'S BANK
OPEN EVERY WORKING
DAY FROM 7-6

12A 12-Pt. No. 4 \$1.75

PROSPERITY
AND INDUSTRY OF
AMERICA

COPPERPLATE ROMAN GIVES
THE EFFECT OF FINE
LITHOGRAPH AND
COPPERPLATE
PRINTING

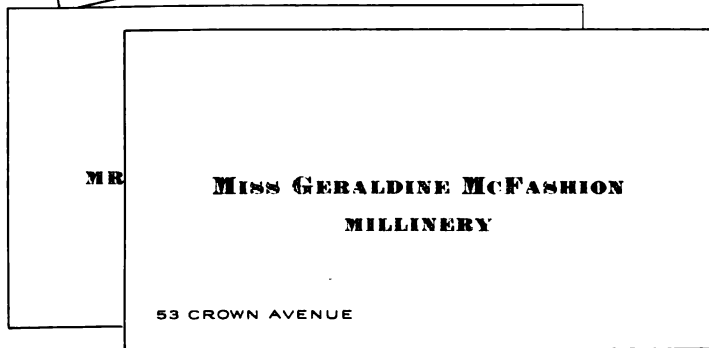
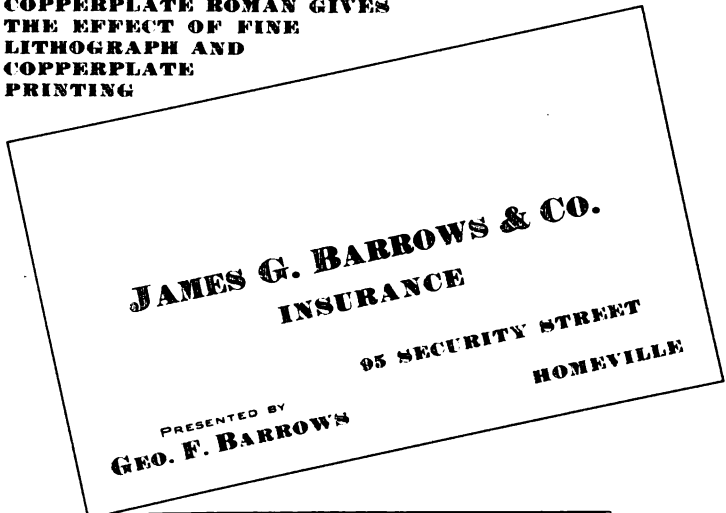

Set with Beveled Quads

THE H. C. HANSEN TYPE FOUNDRY



VICTORIA ITALIC
POINT LINE

30A 6-Pt. No. 5 \$1.00
*AT THE BEGINNING OF THE SEVENTEENTH CENTURY
 OLD ITALIAN BIBLIOGRAPHERS USED UNIFORM INITIALS ONLY 2345*

29A 6-Pt. No. 4 \$1.00
*ONE OF THE FIRST PURPOSES EARLY PRINTING
 WAS APPLIED TO WAS THE MANUFACTURE OF ENGRAVINGS*

23A 6-Pt. No. 3 \$1.00
*THIS SERIES IS APPROVED OF BY THE MOST
 SKILLFUL PRINTERS AS AN ARTISTIC DISPLAY TYPE*

20A 6-Pt. No. 2 \$1.00
*FINE TYPOGRAPHICAL PRODUCTIONS
 HALF TONE ENGRAVINGS OF MARINE VIEWS 7*

20A 6-Pt. No. 1 \$1.00
*SANTIAGO HAS SURRENDERED
 AMERICANS TAKE THE CITY BY STORM*

20A 12-Pt. No. 3 \$1.50
*SPANISH POSSESSIONS
 ON CUBAN SOIL ARE DOOMED 8*

18A 12-Pt. No. 2 \$1.50
*EUROPEAN BANKS
 GREAT INVESTMENTS \$5*

12A 12-Pt. No. 1 \$1.50
*NEW VINTAGE
 BOTTLED IN YEAR 06*

MENU



CLAM CHOWDER

STEAMED CLAMS BROILED ROE

DRESSED LETTUCE

NAHANT POTATO CHIPS

FRIED CLAMS IN CRUMBS OYSTERS

RADISHES

HOT FRENCH ROLLS COLD WHEAT BREAD

ICE CREAM

STRAWBERRY VANILLA HARLEQUIN

ASSORTED CAKE

TEA COFFEE

MANTON, RICHARDS & CO.

JEWELERS

146 DIAMOND STREET

REPRESENTED BY NEW YORK CITY

JOHN ELLSWORTH

10A 18-Pt. No. 2 \$2.00
*AMERICAN
 FINE WARSHIPS*

9A 18-Pt. No. 1 \$2.00
*HARMONY
 GUITAR CLUB*

6A 24-Pt. No. 2 \$2.50
RICH BROKERS INSURED

6A 24-Pt. No. 1 \$2.75
GREAT MERCHANTS 18

THE H. C. HANSEN TYPE FOUNDRY

POSTER BUFFALO OUTLINE

Standard Line

25 pounds and multiples

18-Point

47c. per lb.

IF perchance some of our tariffs are no longer needed for revenue or to encourage and protect our industries at home, why should they not be employed to extend our market

25 pounds and multiples

24-Point

47c. per lb.

IF perchance some of our tariffs are no longer needed for revenue or to encourage and protect 37

25 pounds and multiples

12-Point

50c. per lb.

25 pounds and multiples

14-Point

47c. per lb.

IF PERCHANCE some of our tariffs are no longer needed for revenue or to encourage our industries at home, why should they not be employed to extend and promote our many markets abroad? Then, too, we have inadequate Steamship Services. New lines of Steamers are put

IF perchance some of our tariffs are no longer needed for revenue or to encourage and protect our industries at home, why should they not be employed to extend and promote our markets in the foreign countries? 1

25 pounds and multiples

30-Point

47c. per lb.

IF perchance some of our tariffs are no longer needed for revenue, encourage

50, 75, 100 pounds and over

36-Point

47c. per lb.

IF perchance some of our tariffs are no lon=

See information regarding weights and prices on page 159.



LINING POSTER DE VINNE

Standard Line

25 pounds and multiples 6-Point 76c. per lb.

TRADE statistics indicate that this country is in a state of unexampled prosperity. The figures are almost appalling. They show that we are utilizing our fields and forests and mines and that we are furnishing profitable employment to the millions of our workingmen throughout the United States, bringing comfort and happiness to their homes and making it possible to lay by savings for old age and disability. That all the people are participating in this great prosperity is seen in every American community and is shown by the enormous and unprecedented deposits in our

25 pounds and multiples 8-Point 62c. per lb.

TRADE statistics indicate that this country is in a state of unexampled prosperity. The figures are almost appalling. They show that we are utilizing our fields and forests and mines, and that we are furnishing profitable employment to the millions of our workingmen throughout the United States, bringing comfort and happiness to their homes and making it possible to lay by

25 pounds and multiples 14-Point 47c. per lb.

Trade statistics indicate that this country is in a state of unexampled prosperity. The figures are almost appalling. They show that we are util-

25 pounds and multiples 24-Point 47c. per lb.

TRADE statistics indicate that this country is in a state of unexampled prosperity. The figures are almost

25 pounds and multiples 30-Point 47c. per lb.

BE SURE that all Leads and Slugs are from H. C. Hansen's

50, 75, 100 pounds and over 36-Point 47c. per lb.

THEN you may be certain of absolute accuracy **\$25**

See information regarding weights and prices on page 159.

25 pounds and multiples 10-Point 54c. per lb.

TRADE statistics indicate that the country is in a state of unexampled prosperity.*** The figures are almost appalling. They show that we are utilizing our fields and forests and mines, and that we are furnishing profitable employment to the millions

25 pounds and multiples 12-Point 50c. per lb.

TRADE statistics indicate that this country is in a state of unexampled prosperity. The figures are almost appalling. They show that we are utilizing our fields and forests and mines and that

25 pounds and multiples 18-Point 47c. per lb.

Trade statistics indicate that this country is in a state of unexampled prosperity. The figures



LINING POSTER DE VINNE CONDENSED

Standard Line

25 pounds and multiples 6-Point

76c. per lb.

COMPARISON OF IDEAS IS ALWAYS EDUCATIONAL; and as such instructs the brain and hand of man. Friendly rivalry follows, which is the spur to industrial improvement, the inspiration to useful invention and to high endeavor in all departments of human activity. It exacts a study of the wants, comforts, and even the whims of the people, and recognizes the efficacy of high quality and new prices to win their favor. The quest for trade is an incentive to men of business to devise, invent, improve, and economize in the cost of production. Business life, whether among ourselves or with other peoples, is ever a sharp struggle for success, and it will be none the less so in the future. Without competition we

25 pounds and multiples 10-Point

54c. per lb.

COMPARISON of ideas is always educational; and as such instructs the brain and hand of man. Friendly rivalry follows, which is the spur to industrial improvement, the inspiration to useful invention and to high endeavor in all departments of human activity. It exacts a study of the wants, comforts, and even the whims of

25 pounds and multiples 8-Point

62c. per lb.

COMPARISON of ideas is always educational; and as such instructs the brain and hand of man. Friendly rivalry follows, which is the spur to industrial improvement, the inspiration to useful invention and to high endeavor in all departments of human activity. It exacts a study of the wants, comforts, and even the whims of the people, and recognizes the efficacy of high quality and new prices to win their favor. The quest for trade is an incentive to men of business to devise, invent, improve, and economize in the cost of production. Business life

25 pounds and multiples 12-Point

50c. per lb.

COMPARISON of ideas is always educational; and as such instructs the brain and hand of man, Friendly rivalry follows, which is the spur to industrial improvement, the inspiration to useful invention and high endeavor in all departments of human 1349

25 pounds and multiples 14-Point

47c. per lb.

COMPARISON of ideas is always educational; and as such instructs the brain and hand of man. Friendly rivalry follows, which is the spur to industrial improvement, the inspiration to useful invention and to high endeavor in all departments of 584

25 pounds and multiples 18-Point

47c. per lb.

COMPARISON of ideas is always educational; and as such instructs the brain and hand of man. Friendly rivalry follows, which is the spur to industrial improve-

25 pounds and multiples

24-Point

47c. per lb.

COMPARISON of ideas is always educational; and as such instructs the brain and hand of man

25 pounds and multiples

30-Point

47c. per lb.

Comparison of ideas is always educational; and such instructs the brain

50, 75, 100 pounds and over

36-Point

47c. per lb.

Comparison of ideas is always educational; and such instructs

See information regarding weights and prices on page 159.



POSTER BUFFALO

Standard Line

25 pounds and multiples 6-Point

76c. per lb.

PRICES ARE FIXED with mathematical precision by supply and demand. *The* world's selling prices are regulated by market and crop reports. We travel greater distances in a shorter space of time and with more ease than was ever dreamed of by the fathers. Isolation is no longer possible or desirable. *The* same important news is read, though in different languages, the same day in all Christendom. *The* telegraph keeps us advised of what is occurring everywhere, and the press foreshadows, with more or less accuracy, the plans and purposes of the nations. Market prices of products and of securities are hourly known in every commercial market, and the investments of the people extend beyond their own national boundaries into the remotest parts of the earth. Vast transactions are conducted and international exchanges are made by the tick of the cable. Every event of interest is immediately bulletined and the quick 1472

25 pounds and multiples 10-Point

54c. per lb.

PRICES are fixed with mathematical precision by laws of supply and demand. *The* world's selling prices are regulated by the market and crop reports. We travel greater distances in a shorter space of time and with more ease than was ever dreamed of by the fathers. Isolation is no longer possible or desirable. The same important news is read, though in different languages, the same day in

25 pounds and multiples 8-Point

62c. per lb.

PRICES are fixed with mathematical precision by supply and demand. The world's selling prices are regulated by the market and crop reports. We travel greater distances in shorter space of time and with more ease than was ever dreamed of by the fathers. Isolation is no longer possible or desirable. *The* same important news is read, though in different languages the same day in all Christendom. The telegraph keeps us advised of what is occurring everywhere, and the press foreshadows, with more or less accuracy, the plans and purposes of the nations. Market prices of products and

25 pounds and multiples 12-Point

50c. per lb.

PRICES are fixed with mathematical precision by supply and demand. The world's selling prices are regulated by market and crop reports. We travel a greater distance and in shorter space of time, and with more ease than was ever dreamed of by the fathers. Isolation is no

25 pounds and multiples 14-Point

47c. per lb.

PRICES ARE FIXED with mathematical precision by supply and demand. *The* world's selling prices are regulated by market and crop reports. We can travel a greater distance and in shorter space of time and with more ease than was dreamed of by the fathers. Isolation is no longer possible or desirable. Impor-

25 pounds and multiples 18-Point

47c. per lb.

PRICES are fixed with mathematical precision by the supply and demand. The world's selling prices are regulated by market and crop reports. We travel a greater distance in a shorter space of time

See information regarding weights and prices on page 159.

THE H. C. HANSEN TYPE FOUNDRY

POSTER BUFFALO

Standard Line

25 pounds and multiples

24-Point

47c. per lb.

PRICES ARE fixed with mathematical precision by supply and demand. The selling prices are regulated by market and crop reports. We travel greater 205

25 pounds and multiples

30-Point

47c. per lb.

PRICES ARE fixed with mathematical precision by supply and demand. Isolation is no longer possible or

50, 75, 100 pounds and over

36-Point

47c. per lb.

PRICES ARE FIXED by supply and demand The world's prices are regulated by the market and crop reports

INFORMATION REGARDING POSTER FONTS

Poster fonts are put up as follows: 6 to 30-point, 25 pounds and multiples; 36, 42 and 48-point, 50, 75, 100 pounds and over; 54 and 60 point, 75 pounds and over; 72-point, 100 pounds and over. Sorts sold at second rate. Prices subject to change. Weights are approximate. Poster faces shown generally in stock. Others supplied at short notice.

THE H. C. HANSEN TYPE FOUNDRY

POSTER STRATFORD OLD STYLE

Standard Line

25 pounds and multiples 6-Point 76c. per lb.
SYSTEMS WHICH PROVIDE A MUTUAL EXCHANGE OF
 commodities are manifestly essential to the continued and healthful
 growth of our export trade. We must not repose in fancied security
 that we can forever sell everything and buy nothing. If such a
 thing were possible it would not be best for us or those with whom
 we deal. We should take from our customers such of their products
 as we can use without harm to our industries and labor. Reciprocity
 is the natural outgrowth of our wonderful industrial develop-
 ment under the domestic policy now firmly established. What we
 produce beyond our domestic consumption must have vent abroad

25 pounds and multiples 8-Point 62c. per lb.
SYSTEMS WHICH WILL PROVIDE A MUTUAL
 exchange of commodities are manifestly essential to
 the continued and healthful growth of our export trade.
 We must not repose in fancied security that we can for-
 ever sell everything and buy little or nothing. If such
 a thing were possible it would not be best for us or for
 those with whom we deal. We should take from our
 customers such of their products as we can use without

25 pounds and multiples 10-Point 54c. per lb.
SYSTEMS WHICH PROVIDE MUTUAL
 exchange of commodities are manifestly es-
 sential to continued and healthful growth of
 our export trade. We must not repose in
 security that we can forever sell everything
 and buy little or nothing. If such a thing
 were possible it would not be best for us.
 We should take from our customers such of

25 pounds and multiples 12-Point 50c. per lb.
SYSTEMS WHICH PROVIDE
 a mutual exchange of commodities
 are manifestly essential to the con-
 tinued and healthful growth of our
 export trade. We must not repose
 in fancied security that we can for-
 ever sell everything and buy \$49.85

25 pounds and multiples 18-Point 47c. per lb.
SYSTEMS which provide for mutual exchange of
 commodities are manifestly essential to the continued
 and healthful growth of our export trade. We must

25 pounds and multiples 24-Point 47c. per lb.
SYSTEMS which provide for mutual
 exchange of commodities are manifestly
 essential to the continued and healthful

25 pounds and multiples 30-Point 47c. per lb.
SYSTEMS which provide for a
 mutual exchange of commodi-

50, 75, 100 pounds and over 36-Point 47c. per lb.
Systems which provide a
 mutual exchange of com-

See information regarding weights and prices on page 159.

THE H. C. HANSEN TYPE FOUNDRY

POSTER ANTIQUE No. 31

25 pounds and multiples

18-Point

47c. per lb.

NEXT in advantage to having the thing to sell is to have the convenience to carry it to the buyer. We must encourage our merchant marine. We must have more ships

25 pounds and multiples
8-Point

62c. per lb.

25 pounds and multiples
10-Point

54c. per lb.

25 pounds and multiples
12-Point

50c. per lb.

NEXT IN ADVANTAGE TO having the thing to sell is to have the convenience to carry it to the buyer. We must encourage our merchant marine. We must have many more ships. They must be under the American flag, built and manned and owned by Americans. The construction of a Pacific cable cannot longer be postponed. In the furtherance of these objects of national interest you are performing an important part. If the people will do their part, all the other work will come in good time. Who can tell the thoughts, the ambitions

NEXT in advantage to having the thing to sell is to have the convenience to carry it to the buyer. We must have more ships. They must be under the American flag, built and manned and owned by Americans. The construction of a Pacific cable cannot be later postponed. In furtherance of these objects of a national interest you are performing important and best

NEXT in advantage to having the thing to sell is to have the convenience to carry it to the buyer. In the furtherance and continuance of this object of national interest you are doing an important share of the work on hand. These will not only be profitable to you, but to the buyers of

25 pounds and multiples

24-Point

47c. per lb.

NEXT in advantage to having the thing to sell is to have the convenience to carry it to the buyer. We must encourage our

50, 75, 100 pounds and over

36-Point

47c. per lb.

NEXT in Advantage to having the thing to sell is to have conven-

See information regarding weights and prices on page 169.

POSTER LINING LATIN ANTIQUE

Standard Line

25 pounds and multiples 6-Point

76c. per lb.

The next annual meeting of the United Typothetæ will be held in Buffalo, the last week in August. As the Pan-American Exposition, to be in progress at that time, will make it difficult for visitors to secure quarters in Buffalo unless arrangements are made in advance, all local organizations are requested to send to the secretary of Buffalo Typothetæ as early as possible the lists of delegates and number of members that will probably attend. Every effort will be made to look after all who decide to go. There is no question as to the advantage of visiting Buffalo at that time, as those interested in the graphic arts are aware.

25 pounds and multiples 10-Point

54c. per lb.

The next annual meeting of the United Typothetæ will be held in Buffalo, the last week in August. As the Pan-American Exposition, to be in progress at that time, will make it difficult for visitors to secure quarters in Buffalo unless arrangements are made in advance, all local organizations are requested to send to the secretary of Buffalo

25 pounds and multiples 18-Point

47c. per lb.

THE next annual meeting of the United Typothetæ to be held in **BUFFALO**, the last week in August. As the Pan-American Exposition, to be in pro-

25 pounds and multiples 24-Point

47c. per lb.

There is nothing like the sunshine in April; we fail to see the shine but would like to see everybody happy

See information regarding weights and prices on page 159.

25 pounds and multiples 8-Point

62c. per lb

The next annual meeting of the United Typothetæ will be held in Buffalo, the last week in August. As the Pan-American Exposition, to be in progress at that time, will make it difficult for visitors to secure quarters in Buffalo unless arrangements are made in advance, all local organizations are requested to send to the secretary of Buffalo Typothetæ as early as possible the lists of delegates and number of

25 pounds and multiples 12-Point

50c. per lb.

The next annual meeting of the United Typothetæ will be held in Buffalo, the last week in August. As the Pan-American Exposition, to be in progress at that time, will make it difficult for visitors to secure quarters in Buffalo unless arrangements are made in advance, all local

25 pounds and multiples 30-Point

47c. per lb.

**Happy days
with us once
more, and all
were rushing**

50, 75, 100 pounds and over 36-Point

47c. per lb.

**Do not wait
for things to
turn up, try
for yourself**

THE H. C. HANSEN TYPE FOUNDRY

LINING POSTER HANSEN OLD STYLE No. 40

Standard Line

25 pounds and multiples 6-Point

76c. per lb.

TRADE STATISTICS INDICATE THAT THIS COUNTRY is in a state of unexampled prosperity. The figures are almost appalling. They show that we are utilizing our fields and forests and mines and that we are furnishing profitable employment to millions of our workmen throughout the United States, bringing comfort and happiness to their homes and making it possible to lay by savings for old age and disability. That all the people are participating in this great prosperity is seen in every American community and shown by the enormous and unprecedented deposits in our savings banks. Our duty is the care and security of these deposits, and their safe investment demands the highest integrity and best business capacity of those in charge of these depositories of the people's earnings. We have a vast and intricate business, built up through years of toil and struggle, in which every part of the country has its stake, which will not permit of neglect or of undue selfishness. No narrow, sordid policy will subserve it. The greatest skill and wisdom on the part of manufacturers and producers

25 pounds and multiples 8-Point

62c per lb.

TRADE STATISTICS INDICATE THAT THIS Country is in a state of unexampled prosperity. The figures are almost appalling. They show that we are utilizing our fields and forests and mines and that we are furnishing profitable employment to the millions of our workmen throughout the United States, bringing comfort and happiness to their homes and making it possible to lay by savings for old age and disability. That all the people are participating in this great prosperity is seen in every American community and shown by the enormous and unprecedented deposits in our savings banks. Our duty is the care and security of these deposits and their safe investment demands the highest integrity and 5

25 pounds and multiples

10-Point

54c. per lb.

WHEN YOU CAN OBTAIN A POUND OR A TON OF LEADS OR SLUGS, FULL Length or cut to any thickness, at short notice, remember that they are made at 190-192 Congress Street, by the H. C. Hansen Type Foundry, who, by the use of improved machinery and the best materials obtainable, are enabled to manufacture printers' supplies which are unequalled for quality and accuracy. There are individual consumers who have used over 50,000 pounds of H. C. Hansen's leads and slugs. Write for prices, they are no higher than the inferior article. A complete printing plant can be furnished at short notice, including Presses, Cutters, Imposing Stones, Hamilton Wood Goods, Frames, Stands, Racks, Cases, Type, Leads, Slugs, Quotations, Metal Furniture, Spaces, Quads, Brass Rule, Circles, Ovals, Round Brass Corners, Cutting Rule, Perforating Rule, Mitering Machines, Lead Cutters, Composing Sticks, Benzine Cans, in fact the best of everything for printers

25 pounds and multiples 12-Point

50c. per lb.

TRADE STATISTICS INDICATE This country is in a state of unexampled prosperity. The figures are almost appalling. They show that we are utilizing our fields and forests and mines, and that we are furnishing profitable employment to the millions of our workmen throughout the United States, bringing comfort and happiness to their homes, and making it possible to lay by savings for old age and disability. That all the people are participating in this prosperity is seen in every American community and shown by the enormous and unprecedented deposits in our savings banks. Our duty is the care and security of these

See information regarding weights and prices on page 159.

25 pounds and multiples 18-Point

47c. per lb.

TRADE STATISTICS INDICATE that this country is in a state of unexampled prosperity The figures are almost appalling. They show that we are utilizing our fields and forests and mines, and that we are furnishing profitable employment to the millions of workmen throughout the United States, bringing comfort and

THE H. C. HANSEN TYPE FOUNDRY

POSTER CAMBRIDGE

Standard Line

25 pounds and multiples 6-Point 76c. per lb. 25 pounds and multiples 8-Point 62c. per lb.

**TRADE STATISTICS INDICATE THAT THIS COUNTRY IS IN A STATE OF UN-
Exampld prosperity. The figures are almost appalling. They show that we
are utilizing our fields and forests and mines and that we are furnishing profit-
able employment to the millions of our workingmen throughout the United
States, bringing comfort and happiness to their homes and making it possible
to lay by savings for old age and disability. That all the people are partici-
pating in this prosperity is seen in every American community and shown by
the enormous and unprecedented deposits in our savings banks. Our duty is
the care and security of these deposits, and their safe investment demands the
highest integrity and the best business capacity of those in charge of these de-
positories of the peoples' earnings. We have a vast and intricate business**

**TRADE STATISTICS INDICATE THAT THIS COUNTRY IS IN A
State of unexampld prosperity. The figures are almost appalling.
They show that we are utilizing our fields and forests and mines,
and that we are furnishing profitable employment to the millions
of our workingmen throughout the United States, bringing com-
fort and happiness to their homes, and making it possible to lay
by savings for old age and disability. That all the people are
participating in this prosperity is seen in every American com-
munity and shown by the enormous and unprecedented deposits 5**

25 pounds and multiples 10-Point 54c. per lb. 25 pounds and multiples 12-Point 50c. per lb.

**STATISTICS INDICATE THAT THE COUNTRY IS
In a state of unexampld prosperity. The figures
are almost appalling. They show that we are util-
izing our fields and forests and mines, and that
we are furnishing profitable employment to the
millions of our workingmen throughout the United
States, bringing comfort and happiness to their
homes, and making it possible to lay by savings 2**

**TRADE STATISTICS INDICATE THAT THE
Country is in a state of unexampld pros-
perity. They show that we are utilizing
our fields and forests and mines, and that
we are furnishing profitable employment to
the millions of our workingmen throughout
the United States, bringing comfort and 36**

25 pounds and multiples 14-Point 47c. per lb.

**TRADE STATISTICS INDICATE THAT THE COUNTRY IS IN A STATE OF
Unexampld prosperity. The figures are almost appalling. They show that
we are utilizing our fields and forests and mines, and that we are furnishing
profitable employment to the millions of our workingmen throughout the 35**

25 pounds and multiples 18-Point 47c. per lb.

**TRADE STATISTICS INDICATE THAT THIS COUNTRY IS
In a state of unexampld prosperity. The figures are almost
appalling. They show that we are utilizing our fields and
forests and mines, and that we are furnishing profitable 12345**

25 pounds and multiples 24-Point 47c. per lb.

**STATISTICS INDICATE THAT THIS COUNTRY
Is in a state of unexampld prosperity. The fig-
ures are almost appalling. They show that we
are utilizing our fields and forests and mines 15**

Larger sizes also sold in poster fonts.

See information regarding weights and prices on page 159.

THE H. C. HANSEN TYPE FOUNDRY

LINING POSTER HANSEN OLD STYLE No. 30

Standard Line

25 Pounds and multiples 6-Point 76c. per lb.

SCIENTIST TELEGRAPHING TO MARS WITHOUT WIRES

The latest achievements in electrical science make it possible to send messages from one part of the earth to another through the medium of the electrical wave without wires. In the near future it is predicted that the Niagara falls will be harnessed to produce a sufficient power to meet the requirements of man throughout the civilized world, and there can be no doubt that the close of the present century will be an era in the progress of electrical science in the direction of producing unlimited power from nature itself and a means of communication between the old and the new world of unbounded value to the advancement of commerce and kindred industries now depending upon more primitive modes of

25 Pounds and multiples 8-Point 62c. per lb.

THE GOVERNMENT PRINTING OFFICE BUSY

One of the busiest places in Washington, if not in the entire country, is the printing office of the Government. It is a veritable buzzing hive of industry. During the course of the year the amount of matter turned out of this huge place is tremendous, and fully explains why the office is so constantly busy. The year 1897 was a particularly busy one; in the course of the year the office shipped 318,866 public documents, or 1,045 each day. Of the documents turned

25 Pounds and multiples 10-Point 54c. per lb.

THE HISTORY OF EARLY PRINTING

There is a wide spread belief that typography was, in all its details, a purely original invention. A very popular version of its origin says it was the result of an accidental discovery; a conflicting version says that it was the result of more than eleven years of experiment. Each version teaches us that there was no perceptible

25 pounds and multiples 24-Point 47c. per lb.

MODERN POSTER

Popular type faces for unique poster printing in large fonts suitable for all kinds of display

25 pounds and multiples 30-Point 47c. per lb.

MUSIC SOUNDS

Beethoven was one of the great music composers of olden

See information regarding weights and prices on page 159.

25 Pounds and multiples 12-Point 50c. per lb.

TYPE, CABINETS AND STANDS

Printing is the art of producing impressions from characters or figures, on paper, cloth or other substances. There are several very distinct branches of this important art; as the printing of books with movable types, the printing of engraved copper and steel plates, and the taking of impressions from stone, called lithograph

25 Pounds and multiples 14-Point 47c. per lb.

MR. COLUMBUS, THE POET

The poetical temperament shown in the character of Columbus, seen throughout all his writings, and in all his actions, spread a golden and glorious world about him, and it tinges everything with its gorgeous colors, betraying him with visions

25 pounds and multiples 18-Point 47c. per lb.

A REAL ANTIQUARIAN

Many distinguished scientists versed in Egyptian mythology believe the fabulous doctrines respecting heathen deities to be without foundation, and they are now led to believe that the

50, 75, 100 pounds and over 36-Point 47c. per lb.

FIND RICHES

Klondike is the land of promise for gold seekers

THE H. C. HANSEN TYPE FOUNDRY



MISCELLANEOUS CHARACTERS

COMMERCIAL SIGNS

PER FONT, \$0.90

6-Point
% ¢ lb % ° " ¢ ' @ ¢ /

8-Point
% lb % ° " ¢ ' @ ¢ /

10-Point
% lb % ° " ¢ ' @ ¢ /

12-Point
% lb % ° @ ¢ /

18-Point
% lb ¢ @ ¢

36-Point

@ % lb

Made also on 30-Pt.

MISCELLANEOUS SIGNS

5-Point
- - -) + ▲ I FN AM NT NN

6-Point
g v lb % ° ' x * ° / ÷ ~ -
= + Δ * % " / ¢

6-Point Logos.
A.M. P.M. Passenger

7-Point
@ ¢ lb

8-Point
@ ¢ lb % ° ' x * ° / » « { ¢ i

No. 1 x ± ÷ - ° u + = ∴
No. 2 x ± ÷ - ° + = ∴

9-Point
@ ¢ lb

10-Point
+ x ÷ - ∂ = @ ¢ lb
% ¢ % / ' ° * " # φ « »
No. 1 - + No. 2 - +

11-Point
@ ¢ lb . ~ Cross- Ans. Int.

12-Point
@ ¢ / ' ° ¢ lb % ¢ + # *
+ - x ÷ = «

PRICES

Arithmetical, Algebraic, Astronomical and Miscellaneous Signs sold at pound rates as follows:

	PER LB.		PER LB.
5-Pt.	\$2.80	9-Pt.	\$1.44
6-Pt.	2.00	10-Pt.	1.30
7-Pt.	1.80	11-Pt.	1.22
8-Pt.	1.60	12-Pt.	1.16

Not less than 4 ounces of a character cast
Minimum charge 50c.

+ - x ÷ =

Above signs 50c per font of any size body made

MODERN FRACTIONS

PER FONT, \$0.90

6-Point En 6-Point Em
1 1/2 2/3 3/4 1/3 2/5 3/5 4/5 5/6 7/8

7-Point En
1 1/2 2/3 3/4 1/3 2/5 3/5 4/5 5/6 7/8

8-Point En
1 1/2 2/3 3/4 1/3 2/5 3/5 4/5 5/6 7/8

8-Point Em
1/4 1/2 3/4 1/3 2/3 1/8 3/8 5/8 7/8

9-Point En
1 1/2 2/3 3/4 1/3 2/5 3/5 4/5 5/6 7/8

10-Point En
1 1/2 2/3 3/4 1/3 2/5 3/5 4/5 5/6 7/8

11-Point En
1 1/2 2/3 3/4 1/3 2/5 3/5 4/5 5/6 7/8

12-Point En
1 1/2 2/3 3/4 1/3 2/5 3/5 4/5 5/6 7/8

OLD STYLE FRACTIONS

PER FONT, \$0.90

6-Point Em
1/4 1/2 3/4 1/3 2/3 1/8 3/8 5/8 7/8

8-Point Em
1/4 1/2 3/4 1/3 2/3 1/8 3/8 5/8 7/8

9-Point Em
1/4 1/2 3/4 1/3 2/3 1/8 3/8 5/8 7/8

10-Point Em
1/4 1/2 3/4 1/3 2/3 1/8 3/8 5/8 7/8

11-Point Em
1/4 1/2 3/4 1/3 2/3 1/8 3/8 5/8 7/8 1/6

12-Point Em
1/4 1/2 3/4 1/3 2/3 1/8 3/8 5/8 7/8 1/6

6-POINT GOTHIC FRACTIONS

PER FONT, \$1.00

1/4 1/2 3/4 1/3 2/3 1/8 3/8 5/8 7/8 1/6
9/16 1/16 13/16 15/16

DE VINNE FRACTIONS

PER FONT, \$0.50

6-Point
1/4 1/2 3/4 1/3 2/3 1/8 3/8 5/8 7/8 ¢ %

8-Point
1/4 1/2 3/4 1/3 2/3 1/8 3/8 5/8 7/8 ¢ %

10-Point
1/4 1/2 3/4 1/3 2/3 1/8 3/8 5/8 7/8 ¢ %

12-Point
1/4 1/2 3/4 1/3 2/3 1/8 3/8 5/8 7/8 ¢ %

18-Point
1/4 1/2 3/4 1/3 2/3 1/8 3/8 5/8 7/8 ¢ %

24-Point
1/4 1/2 3/4 1/3 2/3 1/8 3/8 5/8 7/8 ¢ %

MISCELLANEOUS

PER FONT, \$0.50

12-Point Gothic
1/4 1/2 3/4 1/3 2/3 1/8 3/8 5/8 7/8 ¢

24-Point Boldface
1/4 1/2 3/4 1/3 2/3 1/8 3/8 5/8 7/8

36-Point Gothic
1/4 1/2 3/4 1/3 2/3 1/8 3/8 5/8 7/8

RECIPE SIGNS

R R R R R R
1 2 3 4 5 6
R R R R
7 8 9 10

Prices: No. 1 30-Pt., \$0.10; Nos. 2, 3, 4, 24-Pt. each \$0.10; Nos. 5, 6, 7, 18-Pt., each \$0.05; No. 8, 14-Pt., \$0.05; No. 9, 12-Pt., \$0.05; No. 10, 10-Pt., \$0.05. Set of one each of Nos. 7, 9 and 10, \$0.10.



MISCELLANEOUS CHARACTERS

SUPERIOR FIGURES

10-Point Per font, \$1.30
H 1 2 3 4 5 6 7 8 9 0

INFERIOR FIGURES

10-Point Per font, \$1.30
H 1 2 3 4 5 6 7 8 9 0

PIECE FRACTIONS

6-Point	In Preparation	Per font, \$5.00
8-Point		Per font, \$3.60
	1 2 3 4 5 6 7 8 9 0	1 2 3 4 5 6 7 8 9 0
10-Point		Per font, \$2.80
	1 2 3 4 5 6 7 8 9 0	1 2 3 4 5 6 7 8 9 0
12-Point		Per font, \$2.00
	1 2 3 4 5 6 7 8 9 0	1 2 3 4 5 6 7 8 9 0

BLACK STARS

Font containing four of each size, \$0.75
Sold separately if desired



OUTLINE STARS

Either of 3 larger sizes per font of 4, \$0.50
36-Pt., 10 for \$0.50

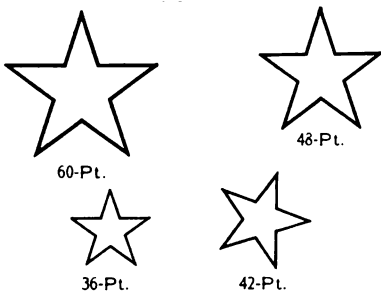

SHADED STARS

Price each: 48-Pt., 20c. 42-Pt., 15c. 36-Pt., 10c.



DOUBLE FISTS

Font of 10, \$1.00 Each, \$0.15



FANCY DASHES

12-Point No. 1, \$0.05 No. 2, \$0.10



LINING JOB DASHES

Assorted, per font, \$1.15

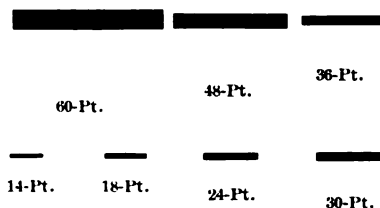

BALLOT SIGNS

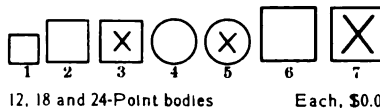

12, 18 and 24-Point bodies Each, \$0.05

PARENTHESIS

On all bodies from 6 to 48-Point. Font, \$0.75

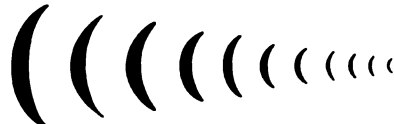

BRACKETS

On all bodies from 6 to 48-Point. Font, \$0.75



SCRIPT LOGOTYPES

Boston, M 190
30-Point \$0.25 \$0.15 \$0.15

CARD PIPS

14-Pt. \$0.10 Set of 4, \$0.25 Per font, \$0.75
6, 18 and 24-Point bodies also made.



CANDLESTICK ORNAMENTS

48-Point Each, \$0.30



FISTS

\$1.25 Per Font. 6 to 12-Point, 5c. ea. 18 and 24-Point, 10c. each. 30 and 36-Point, 15c. each.

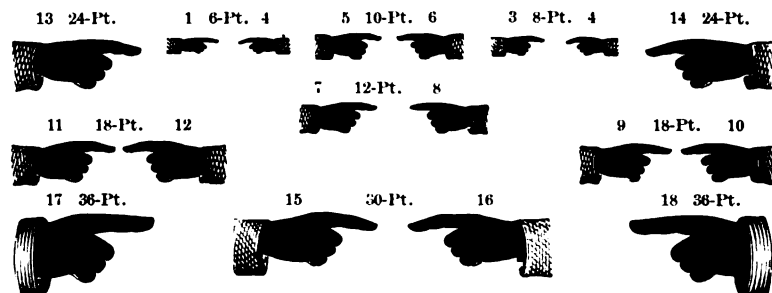

NOTICE!
Remember all of Hansen products are the standard



20



19

48-Point, 25 cents each



STANDARD TYPE MEASURES

(Point System) Every Printing Establishment should have a set

- 3-Em
- 4-Em
- 5-Em
- 6-Em
- 8-Em
- 10-Em
- 12-Em
- 13-Em
- 21-Em
- 30-Em

For setting Composing Sticks perfectly to any number of ems desired, and as standards for cutting Leads and Brass Rule, and for ascertaining the accuracy of Type or any Point System Material, these Measures will be found invaluable in every Printing Office and Type Foundry. They are made in lengths as shown herewith, viz.: 3, 4, 5, 6, 8, 10, 12, 13, 21 and 30 ems 12-Point (Pica), and may be used separately or in combination to make any length desired from 3 to 112 ems pica. They are accurately adjusted to the Point System Standard as adopted by all the Type Founders in the United States.

On the 30 em Pica measure is marked the required number of ems of the different Point System type bodies equal to its length.

EXPLANATION. Place the 30 em Pica Standard in a composing stick, then place the number of ems of any of the bodies marked upon its face in the stick, and if your type is correct it will justify accurately with the Standard.

Price, Complete Set, \$5.00

H. C. HANSEN. 	30 12-PT.	36 10-PT.	40 9-PT.	45 8-PT.	60 6-PT.	360 1-PT.	32	11-PT. AND 1 8-PT.
							51	7-PT. AND 1 3-PT.

HANSEN'S HANDY BRACES

6-Point. Per font. \$1.25

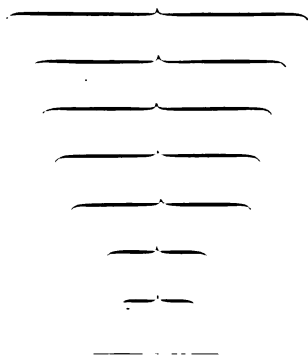

ZION BORDER

24-Point. 18 inches. \$1.00

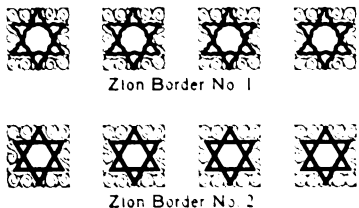

RUSSIAN CHARACTERS

10-Point. These characters are made to line with our Roman No. 4, shown on pages 22-23.

\$1.30 per lb. No less than 4 oz. each cast.

- | | | | | | | | | | | | |
|----|----|----|----|----|----|----|----|----|----|----|----|
| Ъ | Г | Д | Ж | З | И | Й | К | Л | Г | | |
| 1 | 2 | 3 | 4 | 5 | 6 | 7 | 8 | 9 | 10 | | |
| Н | І | У | Ф | Ц | Ч | Ш | Щ | Ы | Ь | Ъ | Э |
| 11 | 12 | 13 | 14 | 15 | 16 | 17 | 18 | 19 | 20 | 21 | 22 |
| Ю | Я | Ө | У | б | в | г | д | ж | э | и | й |
| 23 | 24 | 25 | 26 | 27 | 28 | 29 | 30 | 31 | 32 | 33 | 34 |
| К | Л | М | Н | П | Т | І | Г | Ф | Ц | Ч | Ш |
| 35 | 36 | 37 | 38 | 39 | 40 | 41 | 42 | 43 | 44 | 45 | 46 |

- | | | | | | | | | | |
|----|----|----|----|----|----|----|----|----|----|
| Щ | Ъ | Ы | Ь | Ъ | З | Ю | Я | Ө | У |
| 47 | 48 | 49 | 50 | 51 | 52 | 53 | 54 | 55 | 56 |

12-Point \$1.16 per lb.

- | | | | |
|----|----|----|----|
| Г | і | Г | і |
| 57 | 58 | 59 | 60 |

EDITORIAL POINTERS

6-Point

- | | |
|-------------|-------------|
|
343. 5c |
344. 5c |
|
345. 5c |
346. 5c |

8-Point

- | | |
|--------------|--------------|
|
347. 10c |
348. 10c |
|--------------|--------------|

12-Point

- | | |
|--------------|--------------|
|
349. 10c |
350. 10c |
|--------------|--------------|

18-Point. 351. 10c

IMPRINTS

6-Point. Imprints made to order

THE EDWARD MADISON COMPANY, MONTECLAIR, N. J.

Special Designs made to order



THE H. C. HANSEN TYPE FOUNDRY



PERPETUAL CALENDARS

Fonts of Perpetual Calendars contains fifty-two logotypes, rules and font for month and year; can be used for any month in any year; can be changed in a few minutes



Hansen's Perpetual Calendar No. 2. Price, \$2.50
Different style plain rule border
furnished if desired

MOONS

Made to run in color with
Calendar No. 1
Per set of four, \$0.35

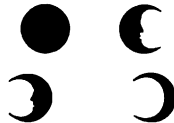

24-POINT

Per set of four, \$0.35



Hansen's Perpetual Calendar No. 1. Price, \$2.50

MAILING TYPE

Cast on 10-Point or Long Primer size, and are put up in fonts carefully proportioned for subscription lists. A font contains Roman for names; Gothic for abbreviations, cast on em and en bodies; Figures on en body, and Clarendon for Post Offices, addresses, etc. Sorts furnished at very short notice. A list of 1,000 names will require about 100 lbs. of Long Primer or 10-Point Mailing Type. 54 cents per pound. Subject to discount. For Mailing Galleys see page 334.

READING	MALDEN	CHELSEA	BOSTON
WERussell 23 ⁷ / ₈ 94	Mrs MaySnow 20 ⁵ / ₈ 89	ClaraJohnson 20 ⁷ / ₈ 94	Miss KateGohmme 30 ⁵ / ₈ 96
THNewton 30 ⁸ / ₈ 86	BHBluejeans 27 ⁸ / ₈ 84	CAMoneh 14 ⁸ / ₈ 93	RevSHStoneBox2 26 ⁸ / ₈ 93
RobtLMorse 26 ⁵ / ₈ 78	Mrs WmEarly 30 ⁵ / ₈ 96	WmCoughlin 29 ⁰ / ₈ 96	Dr HGolden 24 ¹ / ₈ 82
MEGrover 23 ⁵ / ₈ 84	Rev JasAKing 24 ⁷ / ₈ 95	GusJohnson 25 ⁰ / ₈ 96	GeoTolstrup 30 ⁸ / ₈ 87
STWhite 30 ⁸ / ₈ 75	FNHaddon ⁵ / ₈ 56	GeoMoller 16 ⁸ / ₈ 87	GenSPerry 23 ⁸ / ₈ 89
WPParsons 29 ⁵ / ₈ 79	HShannon 30 ⁷ / ₈ 85	John Williams 30 ¹ / ₈ 98	Mrs GDHopper 26 ⁸ / ₈ 95

10-POINT GERMAN

Cast with all the German accents and combinations
10A \$1.00 35a \$1.50 \$2.50 25 lbs. and over at Roman Rates

Der Erste, welcher die Materie und Poesie mit einander verglich, war ein Mann von feinem Gefühle, der von beiden Künsten ein ähnliche Wirkung auf sich verspürte. Beide, empfand er, stellen uns abwesende Dinge als gegenwärtig, den Schein als Wirklichkeit

ABCDEFGHIJKLMNOPQRSTUVWXYZ
12345 abcdefghijklmnopqrstuvwxyz #67890
Ä Ö Ü ä ö ü ch ll ff fi fl ff ii it h b

Special accents are made for this type \$2.00 per font

Q R S ä å è ì ï ù ú g k l n r f

For other German faces see pages 38 and 39.

10-POINT SPECIAL LINO. GOTHIC

25 pounds and multiples, 54c. per pound

A VERY POPULAR LETTER FOR NEWSPAPER HEADINGS AND SUB-HEADINGS

ALL HANSEN TYPE IS CAST FROM SUPERIOR COPPER-ALLOY METAL WHICH IS EXTREMELY DURABLE. THE MOST ACCURATE TYPE AND PRINTERS SUPPLIES ARE THOSE

MADE BY THE H. C. HANSEN TYPE FOUNDRY
BOSTON NEW YORK

THE H. C. HANSEN TYPE FOUNDRY



CALENDAR AND COMMERCIAL FIGURES

Prices and directions for ordering on page 179

FIGURE NO. 50		Pt. Set
6-Point	c	3
1234567890	\$1234.30	1234567890
8-Point		3½
1234567890	\$2734.20	1234567890
10-Point		4
1234567890	59c	1234567890
12-Point		5
1234567890		1234567890
14-Point		6
1234567890		1234567890
18-Point*		7
12345	\$20.96	67890
24-Point		9
12345	29c	67890
30-Point		10
12345		67890
36-Point		12
12345	\$67890	
42-Point		16
1234	\$7.89	
48-Point		18
\$123	890	
54-Point		20
1234567		
72-Point*		25
123	\$48	

FIGURE NO. 51		Pt. Set
6-Point*	c	3½
1234567890	\$649.46	1234567890
8-Point*		4
1234567890	2390c	1234567890
10-Point*		5
1234567890	\$23	1234567890
12-Point*		6½
1234567890		1234567890
14-Point*		8
1234567890	\$345.00	
18-Point*		10
12345	30c	67890
24-Point*		12
12345		67890
30-Point*		15
1236		7890
36-Point*		17½
123456	7c	
42-Point*		22
1235	.67	
48-Point*		26
123	5c	
60-Point*		33
1		234
72-Point*		37
1		234

FIGURE NO. 52		Pt. Set
A6-Point		4
1234567890	\$120.30	1234567890
B6-Point		4
1234567890	\$134.99	1234567890
C6-Point		5
1234567890	60c	1234567890
8-Point		7
1234567890		123457890
10-Point		9
2356	\$458	7894
12-Point		10
12345	84c	67890
18-Point†		14
12345		67890
24-Point*		19
12345	6c	
36-Point†		28
123	45	
48-Point†		41
1980		

FIGURE NO. 53		Pt. Set
6-Point		4½
1234567890	\$123.90	1234567890
8-Point†		6
1234567890		1234567890
10-Point†		7
12345	\$12.34	67890
12-Point†		9
12345	.25	67890
14-Point†		11
12345		67890
18-Point†		11
12345		67890
24-Point†		13
12345		67890

*Figure 1 thin

†Figure 1 thick and thin

Dollar mark, lower case c, period and commas sold separately

THE H. C. HANSEN TYPE FOUNDRY



CALENDAR AND COMMERCIAL FIGURES

Prices and directions for ordering on page 179

FIGURE NO. 53. CONT. Pt. Set
 30-Point† 17
2134 56c
 36-Point† 25
718.90
 42-Point* 28
12.45
 48-Point* 33
12 35
 54-Point* 40
5 6 7

FIGURE NO. 54

8-Point 4
 1234567890 1234567890 1234567890
 10-Point 5½
 1234567890 1234567890
 12-Point 7
 1234567890 123456780
 18-Point 9
 1234567890 23c.
 24-Point 11
 1234567890 \$8

FIGURE NO. 55

6-Point 4
 1234567890 13579 1234567890
 8-Point 5
 1234567890 \$9.09 1234567890
 10-Point 6
 1234567890 1234567890

FIGURE NO. 55. CONT. Pt. Set
 12-Point† 7
 12345 12345789 67890
 18-Point 9
 12345 23c 67890
 24-Point 11
 12345 67890
 30-Point 13
 12345 67890
 36-Point 17
 123 4 567
 42-Point 18
 1357 89c
 48-Point 23
 123 456

FIGURE NO. 56

6-Point† 9
12345 12345 67890
 8-Point† 10
1234567890 1245
 10-Point† 12
1 234 56c 7890
 12-Point† 15
1234567890
 14-Point† 17
1 234 5678
 18-Point† 21
234 567
 24-Point† 25
3 456 7
 30-Point* 34
82 30

FIGURE NO. 57 Pt. Set
 6-Point* c 5½
1234567890 23c. 1234567890
 8-Point* 7
1234567890 1234567890
 10-Point* 8
12345 142 67890
 12-Point* 10½
12345 28 67890
 18-Point 13
12345 67890
 24-Point* 16
1234 \$678
 30-Point* 24
123 458
 36-Point* 30
23415
 48-Point* 39
1 2 8
 60-Point* 50
1 3 5

FIGURE NO. 58

6-Point* 40 5
1234567890 12346 1234567890
 6-Point* 41 5½
1234567890 1234567890
 6-Point* 42 6
123456 789012345 67890
 6-Point* 43 7
1234567890 1234567890
 12-Point* 44 8
1234567890 \$1234.56
 12-Point* 45 10
1234567890 1234
 12-Point* 46 12
12 345678 90

*Figure 1 thin

†Figure 1 thick and thin

Dollar mark, lower case c, period and commas sold separately

THE H. C. HANSEN TYPE FOUNDRY



CALENDAR AND COMMERCIAL FIGURES

Prices and information for ordering on page 179

FIGURE NO. 58. CONT.

18-Point* 47	Pt. Set 15
1234567890	
18-Point* 48	19
12345678	
24-Point* 49	24
13 67 89	

FIGURE NO. 59

18-Point* 10	c
1234 56c 7890	
24-Point* 12	
12345678 \$90	
30-Point* 15	
1234 5 6789	
36-Point* 17½	
1234 5678	
42-Point* 22	
123 456	
48-Point* 28	
12 3 45	
60-Point* 33	
2 3 4 5	
72-Point* 37	
1 2 3 4	

FIGURE NO. 60

6-Point 4	c
1234567890 \$12.45 1234567890	
8-Point 5	
1234567890 12345 1234567890	
10-Point 5½	
1234567890 98c 123456790	
12-Point 7	
1234567890 34567890	
14-Point 8	
1234567890 234567	
18-Point 10	
1234567890 123	
24-Point 14	
13456890 12	
30-Point 16	
1234 5670	
36-Point 21	
123 456	
42-Point 23	
123 568	
48-Point 28	
123 45	
60-Point 34	
2 3 4 5	

FIGURE NO. 61

6-Point 4	c
1234567890 1234567890 1234567890	
8-Point 5	
1234567890 89c 1234567890	
10-Point 5½	
1234567890 1234567890	

FIGURE NO. 61. CONT.

12-Point* 7	c
1234567890 \$1.23 456	
14-Point* 9	
1234567890 123	
18-Point* 10½	
1234567890 234	
24-Point* 13	
1234567890 3	
30-Point* 17	
1234 5678	
36-Point* 21	
234 567	
42-Point* 25	
123456	
48-Point* 30	
12345	

FIGURE NO. 62

6-Point* 6	
1234567890 1234567890	
8-Point* 7½	
1234567890 12345678	
10-Point* 8½	
1234567890 12c 345	
12-Point* 11	
1234567890 \$23	
14-Point* 14	
12345 67890	
18-Point* 16	
12345 6789	
24-Point* 20½	
1234 567	
30-Point* 25	
123 579	

*Figure 1 thin

†Figure 1 thick and thin

Dollar mark, lower case c, period and commas sold separately



CALENDAR AND COMMERCIAL FIGURES

Prices and directions for ordering on page 179

FIGURE NO. 62. CONT.

36-Point*	Pt. Set
	31
12345	
42-Point*	37
12 34	
48-Point*	45
2 3 4	

FIGURE NO. 63

6-Point*	1234567890	1234567890	1234567890	Pt. Set
				3
8-Point	1234567890	12345	1234567890	4
10-Point*	1234567890	1234	1234567890	4
12-Point*	1234567890	39c	1234567890	5
14-Point*	1234567890	\$12345678		7
18-Point*	123	4567890	123	8
24-Point*	12	345678	90	10
30-Point*	12	34567	89	13
36-Point†	12	3456	78	15
42-Point*	2	3456	7	18
48-Point*	23	4	56	21

*Figure 1 thin

FIGURE NO. 64

6-Point	c	Pt. Set
		4
1234567890	1234567890	1234567890
8-Point		4½
1234567890	1234567890	\$1234678
10-Point		5½
1234567890	123	1234567890
12-Point		7
1234567890	12c	34567
18-Point		8
1234567890		123456
24-Point†		12
12c	123456890	
30-Point†		14
12345	67890	
36-Point†	42-Point face	15
2345	67890	
42-Point†		15
34567	\$890	
48-Point†		19
1345	680	

FIGURE NO. 65

6-Point†	1234	567890	1234	Pt. Set
				9
8-Point†	1234567890	87c		10
10-Point†	12345	\$67890		12
12-Point†	1234567890			15
18-Point†	1234567			21
24-Point†	56789			27
36-Point†	1234			38

FIGURE NO. 66

6-Point		Pt. Set
		3
1234567890	1234567890	1234567890
8-Point		4
1234567890	1234567890	1234567890
10-Point		5
1234567890	1234	1234567890
12-Point		6
1234567890	\$1234567890	
14-Point		7
1234567890	1234567890	
16-Point		9
123	4567890	123
18-Point		9
12	34567890	12c
20-Point		10
1234567890	1234	
24-Point		12
12	345678	90
30-Point		15
12	34567	89
36-Point		18
1	23456	7
42-Point		21
5	6789	0
54-Point		27
1	2345	
72-Point		36
1	346	

Dollar mark, lower case c, period and commas sold separately

THE H. C. HANSEN TYPE FOUNDRY



CALENDAR AND COMMERCIAL FIGURES

Prices and directions for ordering on page 178

FIGURE NO. 67		Pt. Set
8-Point*		6
1234567890	1234567890	
10-Point*		7
1234567890	1234567890	
12-Point*		9
1234567890	123456	
18-Point*		13
12345678	90c	
24-Point*		18
1234	\$567	
36-Point*		24
234567		
48-Point		35
2345		

FIGURE NO. 68		
6-Point		4
1234567890	1234567890	1234567890
8-Point		4½
1234567890	\$12345	1234567890
10-Point		6
1234567890	12c	34567890
12-Point		7
1234567890		1234567890
16-Point		8
1234567890		1234567
18-Point		10
12345	\$85	67890
24-Point		12
12	345678	90
30-Point		15
123456789		
36-Point		18
23456789		

FIGURE NO. 68. CONT.		Pt. Set
42-Point		21
567	890	
48-Point		24
123456		

FIGURE NO. 69		
6-Point		3
1234567890	1234567890	1234567890
8-Point		4
1234567890	\$12345	1234567890
10-Point		5
1234567890	39c	1234567890
12-Point		6
1234567890		1234567890
24-Point		14
12345	67890	

FIGURE NO. 70		
6-Point 2		4
1234567890	1234567890	1234567890
6-Point 3		4½
1234567890	12345	1234567890
6-Point 4		6
12345	1234567890	67890
12-Point 5		7
1234	1234567890	5678
12-Point 6		8
123	1234567890	656
12-Point 7		10
1234567890	\$45	
12-Point 8		12
12345	67890	
18-Point 9		14
12345	67890	
18-Point 10		16
123456789		
24-Point 11		20
1234567		

FIGURE NO. 71		Pt. Set
6-Point		3
1234567890	1234567890	1234567890
8-Point		4
1234567890	1234567890	1234567880
10-Point*		5
1234567890	\$89.35	1234567890
12-Point*		6
1234567890		1234567890
18-Point*		9
12345	1523	67890
24-Point*		12
12345	67890	
36-Point*		18
1234	5678	
48-Point*		24
23	4	59

FIGURE NO. 72		
6-Point		3
1234567890	\$209.72	1234567890
8-Point		4
1234567980		1234567890
10-Point		5
1234567890	1345	1234567890
12-Point		6
1234567890		1234567890
18-Point*		9
12345	653	67890
24-Point*		13
12345	67890	
30-Point*		15
1234	5680	
36-Point*		18
2134	69c	
48-Point*		23
123	490	

Figure 1 thin

†Figure 1 thick and thin

Dollar mark, lower case c, period and commas sold separately

THE H. C. HANSEN TYPE FOUNDRY



CALENDAR AND COMMERCIAL FIGURES

Prices and directions for ordering on page 179

FIGURE NO. 73		Pt. Set
6-Point	1234567890	^c 4½
8-Point	1234567890	5½
10-Point	12345 13459 67890	7
12-Point	12345 2345 67890	8
14-Point	13456 98 37894	9½
18-Point	12345 67890	12
24-Point	134 9c 567	16
30-Point	123 896	18
36-Point	123 456	23
48-Point	23 56	31½
60-Point	67 8	42
72-Point	360	48

FIGURE NO. 74		Pt. Set
12-Point	12345 2479 67890	^c 8
14-Point	12345 \$30 67890	9½
18-Point	12345 67890	12

FIGURE NO. 74. CONT.		Pt. Set
24-Point	146 7 890	16
30-Point	123 4 567	18
36-Point	236 790	23
48-Point	76 54	31½

FIGURE NO. 75		Pt. Set
10-Point	1234567890 1234 1234567890	5
12-Point	1234567890 \$1234567890	6
18-Point	1234567890 12c	9
24-Point	12345 67890	12
30-Point*	1235 6 7890	15
36-Point	12356789	18
42-Point	123 568	21
48-Point	12 3 57	24
60-Point	12 35	30

FIGURE NO. 75. CONT.		Pt. Set
72-Point	1358	36

FIGURE NO. 76		Pt. Set
6-Point	1234567890 123456790 1234567890	^c 3
8-Point	1234567890 \$90.58 1234567890	4
10-Point	1234567890 1234567890	5
12-Point	1234567890 1234567890	6
14-Point	12345 42135 67890	7
18-Point	12345 346 67890	9
24-Point	12345 67890	12
30-Point	1284 5679	15
36-Point	12 3c 34	18
48-Point*	123479	24
60-Point*	12 39	30
72-Point*	3425	36

*Figure 1 thin

†Figure 1 thick and thin

Dollar mark, lower case c, period and commas sold separately



CALENDAR AND COMMERCIAL FIGURES

Prices and directions for ordering on page 179

FIGURE NO. 77		Pt. Set
6-Point	c	4
1234567890	\$98.46	1234567890
8-Point		5
1234567890	98	1234567890
10-Point		5
1234567890	347	1234567890
12-Point		6
1234567890	1234567890	
14-Point		7
1234567890	124567890	
18-Point		9
1234	\$39.56	7890
20-Point		10
1234	91c	67890
24-Point		12
12345	67890	
30-Point		15
123	9c	456
36-Point		18
12345678		
42-Point		21
124	384	
48-Point		24
12	9	34

FIGURE NO. 78		Pt. Set
6-Point		4
1234567890	3128	1234567890
8-Point		5½
1234567890	1234567890	
10-Point		6
1234567890	1234567890	
12-Point		7
12345	\$123.00	67890
18-Point*		10
1234	\$1.36	7890

FIGURE NO. 78. CONT.		Pt. Set
24-Point		12½
12345	67890	
30-Point		15
124	59	678
36-Point		20
124	578	
42-Point		24
24c	90	
48-Point*		27
18	6	96

FIGURE NO. 79		Pt. Set
18-Point*	c	9½
12345	\$38	67890
24-Point*		13
12345	67890	
36-Point*		17
1234	5678	
42-Point*		21
1234567		
48-Point*		24
24	5	67
54-Point*		29
32	49	

FIGURE NO. 80		Pt. Set
6-Point*		6
1234567890	1234567890	
8-Point*		6½
1234567890	1234567890	
10-Point*		8
12345	\$120.42	67890
12-Point*		9
12345	98c	6789
18-Point*		12
12345	67890	
24-Point*		16
315	6	789
30-Point*		20
123	457	
36-Point*		23
157	890	
48-Point*		32
134	7	

FIGURE NO. 81		Pt. Set
10-Point		4
1234567890	\$28.59	1234567890
12-Point		5
1234567890	58c	1234567890
18-Point*		7
789	1234567890	123
24-Point		9
12345	2578	67890
36-Point*		12½
12345	67890	
48-Point		15
1234	5	6789

*Figure 1 thin

†Figure 1 thick or thin

Dollar mark, lower case c, period and commas sold separately

THE H. C. HANSEN TYPE FOUNDRY



CALENDAR AND COMMERCIAL FIGURES

Prices and directions for ordering on page 178

FIGURE NO. 82

18-Point Pt. Set 8
12 1234567890 34

24-Point 10
12345 123 67890

36-Point 14
1234567890

42-Point 18
12345678

FIGURE NO. 83

18-Point 8
1234567890 \$0790

24-Point 10
12345 123 67890

36-Point 14
12 4560 90

42-Point 18
12345678

FIGURE NO. 84

6-Point 4
1234567890 34568 1234567890

8-Point 4½
1234567890 \$109.97 1234567890

10-Point 5
1234567890 24 1234567890

12-Point 6
1234567890 1234567890

14-Point 8
12345 1234 67890

18-Point 9
12345 27 67890

24-Point 12
12345 8 67890

30-Point† 15
1234 5678

FIGURE NO. 84. CONT.

36-Point† Pt. Set 18
1256 7890

42-Point† 21
123 469

48-Point† 24
134 598

FIGURE NO. 85

12-Point* 6
1234567890 1234567890

18-Point* 7
1234567890 1234567890

24-Point* 10
12345 32 6780

30-Point* 13
12345 67890

36-Point* 15
2134 5 6890

FIGURE NO. 86

18-Point* 7½
12345 1234567 67890

24-Point* 10
12345 123 67890

30-Point* 11
12345 67890

36-Point* 14
12345 7890

42-Point* 16
123456789

48-Point* 19
125 6 789

FIGURE NO. 87

6-Point c Pt. Set 4
1234567890 34598 1234567890

8-Point 4½
1234567890 234 1234567890

10-Point 6
1234567890 1234567890

12-Point 6½
1234567890 1234567890

14-Point 7
12345 23598 67890

18-Point 9
12345 31 67890

24-Point 12
1234 5c 67890

30-Point 14
12345 67890

36-Point 18
12345678

FIGURE NO. 88

6-Point 4½
1234567890 345 1234567890

8-Point 6
1234567890 1234567890

10-Point 7
12345 2456 67890

12-Point 8
12345 \$5.00 67890

18-Point† 11
12345 67890

24-Point† 13
12345 67890

30-Point† 17
123 4 567

36-Point† 20
192 653

42-Point† 24
13 4 78

48-Point† 28
21 35

*Figure 1 thin

†Figure 1 thick or thin

Dollar mark, lower case c, period and commas sold separately

THE H. C. HANSEN TYPE FOUNDRY



FIGURES FOR TABULAR WORK

No. 18-POINT Pt. Set

288* 3568 19
327* 23456789 8
328 2345678 10
329* 4567 17

Table with columns A.M., P.M., A.M., P.M. for font 3568.

Table with columns A.M., P.M., A.M., P.M. for font 23456789.

Table with columns A.M., P.M., A.M., P.M. for font 2345678.

5-Pt. Light No. 439 Heavy No. 440 \$1.20 per lb. Both figures 2 1/2-Pt. set

5-Pt. No. 442 \$1.20 per lb. 4-Pt. set

5-Pt. No. 441 \$1.20 per lb. 4-Pt. set

20-POINT

101 23456789 9
102† 23456 13
243† 23456 13

Table with columns STATIONS, A.M., P.M., A.M., P.M. for font 23456789.

Table with columns STATE, 1907, 1909, Gain for various states.

5 1/2-Pt. No. 444. 3 1/2-Pt. set. 88c. per lb.

5 1/2-Pt. Gothic No. 445 Boldface No. 446 88c. per lb. 2 1/2-Pt. set. 4 1/2-Pt. set.

24-POINT

392* 234567 12
393 3456 16
39 3478 16

Table with columns P.M., A.M., STATIONS, A.M., P.M. for font 234567.

6-Pt. Roman No. 4 Gothic No. 448. 3-Pt. set 3-Pt. set 76c. per lb.

Calendar Figures

Put up in fonts sufficient to set any one month. The following numbers, shown on previous pages, are those put up in fonts for Calendar purposes: 50, 51, 57, 59, 60, 61, 64, 73, 74, 76, 77, 79 and 87.

1908 SEPTEMBER 1908

Calendar grid for September 1908 with days of the week and dates.

12-Pt. No. 74 8-Pt. Set

SIZES AND PRICES

Table listing font sizes and their corresponding prices.

How Figures Are Furnished, Prices and General Information

Figures are put up in fonts of 2 1/2 pounds each from 5 to 12-point, also in 5 pound fonts each from 5 to 72-point. As a rule, figures shown on pages 170 to 179 are kept in stock or will be cast to order at short notice.

The "point set" of the figure refers to the width of the figure body in points.

All figures and extra characters also cast to order in quantities of 4 ounces each, and over.

Rimmed, shaded and script figures sold at third class rates. Special figure spaces cast to order.

PRICE LIST OF 2 1/2 POUND FONTS. 5 TO 12 POINT

Table listing prices for 2 1/2 pound fonts from 5 to 12 point.

PRICE LIST OF 5 POUND FONTS. 5 TO 72 POINT

Table listing prices for 5 pound fonts from 5 to 72 point.

*Figure 1 thin

†Figure 1 thick and thin

Set indicates thickness of figures

Prices and particulars on this page

THE H. C. HANSEN TYPE FOUNDRY



ELECTROTYPED DATE LINES

Prices are for any city as per styles below Solid Metal Base

No. 1. 75 cents	<i>Barre, Vt.,</i>	190	No. 8. 50 cents	<i>Portland, Maine,</i>	190
No. 2. 75 cents	<i>Cleveland,</i>	190	No. 9. 50 cents	Worcester, Mass.,	190
No. 3. 50 cents	UTICA, N. Y.,	190	No. 10. 50 cents	Philadelphia, Pa.,	190
No. 4. 50 cents	NEWPORT, R. I.,	190	No. 11. 60 cents	<i>St. Paul, Minn.,</i>	190
No. 5. 50 cents	BOSTON, MASS.,	190	No. 12. 60 cents	<i>Newton, Mass.,</i>	190
No. 6. 50 cents	DETROIT, MICH.,	190	No. 13. 60 cents	<i>Quincy, Mass.,</i>	190
No. 7. 50 cents	<i>DENVER, COL.,</i>	190	No. 14. 60 cents	New York,	190

NEWSPAPER SUB-HEADINGS

ELECTROTYPED

Trimmed to 13 ems pica	Solid Metal Base	Price 50 cents each
No. 1	THE REPUBLICAN	No. 9
No. 2	THE CHICAGO DISPATCH	No. 10
No. 3	The Northampton Gazette	No. 11
No. 4	Galena Transcript	No. 12
No. 5	Jacksonville Register	No. 13
No. 6	THE SUNDAY POST	No. 14
No. 7	BOSTON JOURNAL	No. 15
No. 8	BOSTON GLOBE	No. 16
		BOSTON AMERICAN
		NEW BRUNSWICK HERALD
		GREENFIELD DAILY RECORDER
		BRISTOL COUNTY REPORTER
		ST. PAUL RECORD
		The Maine Citizen
		HUDSON BULLETIN
		Eastport Observer

THE H. C. HANSEN TYPE FOUNDRY



ELECTROTYPED NEWSPAPER HEADINGS

Other Styles and Sizes Made to Order

Special Headings Designed and Drawn upon Request

60-Point Boston Gothic

One word, \$1.00; two words, \$1.50; each additional word, \$0.40

ST. LOUIS EAGLE

54-Point Caslon Old Style No. 2

One word, \$1.00; two words, \$1.50; each additional word, \$0.40

DAILY GLOBE

60-Point Buffalo

One word, \$1.00; two words, \$1.50; each additional word, \$0.40

Les Critique

60-Point Mastodon

One word, \$1.00; two words, \$1.50; each additional word, \$0.40

EXETER NEWS

72-Point Mastodon

One word, \$1.00; two words, \$1.50; each additional word, \$0.40

Olnie Record

72-Point Caslon Old Style No. 2

One word, \$1.00; two words, \$1.50; each additional word, \$0.40

Boston Leader

72-Point Cambridge

One word, \$1.00; two words, \$1.50; each additional word, \$0.40

DAILY HERALD

THE H. C. HANSEN TYPE FOUNDRY



POINTERS

GROUP C. FONT \$1.30

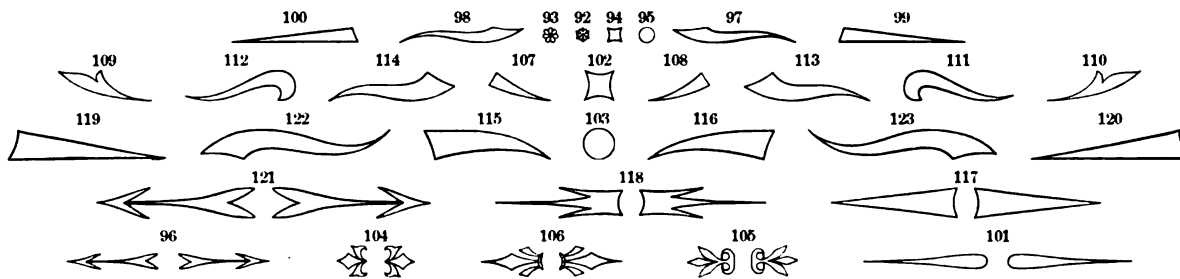

GROUP D. FONT \$1.90

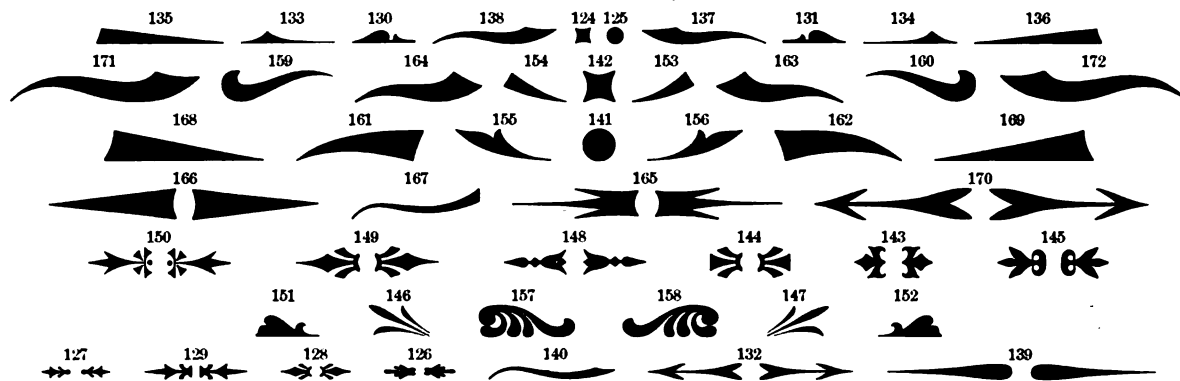

POINTERS No. 1

FONT \$1.25

A font contains 48 of character No. 43; 20 of 44; 4 each of 45, 46, 53, 54; 3 each of 47, 48, 49, 50, 51, 52; 2 each of 55, 56, 57, 58; 4 of 69. Cast on 6-Point and 12-Point bodies. Numbers 45, 46, 47, 48, 53, 54, 55 and 56 are made to line with our 2-Point Rule No. 109.

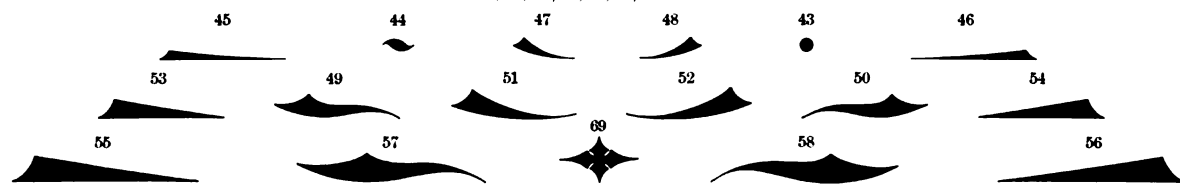

SHADED POINTERS.

FONT \$1.25

Same number of characters as in Pointers above.

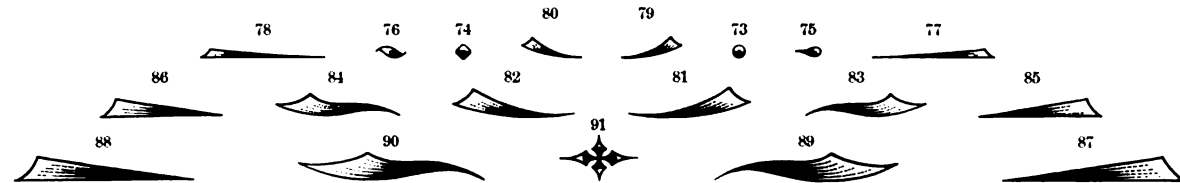

ARROW POINTERS.

Cast on 12-Point body, 2j, 3, 3j, 4 and 4j ems set, and may be used right and left.

FONT \$1.00

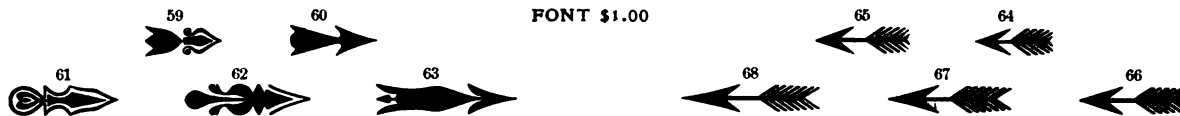

Single characters of any above, 10 cents each

Do not mutilate book

Order by name and number

THE H. C. HANSEN TYPE FOUNDRY



HANSEN AD. CORNERS

Cast from Superior Copper Alloy Metal

Ad. Corners, per font containing four each size, \$2.00
Single set of four, 60 cents

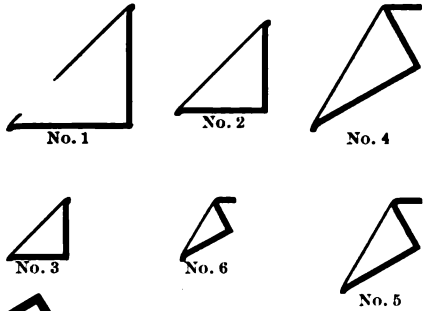

3-Pt. Face Ad. Corners, per font containing four each size, \$2.00
Single set of four, 60 cents

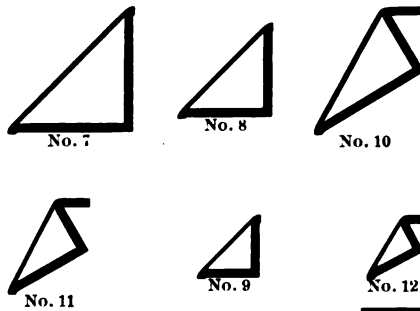

Novel and Catchy

Are the effects that can be quickly and easily obtained with

Hansen Ad. Corners

Used with brass rule of corresponding face they add to value of advertising display

METAL ROUND CORNERS

3-Pt. Metal Round Corners, \$1.00 per font
Contains 3 sets each

12-Pt. Metal Round Corners, 75c. per font
Contains 4 sets each. On 24 pt. body

6-Pt. Metal Round Corners, 75c. per font
Contains 6 sets each. On 12 pt. body



SOMETHING NEW

SOMETHING USEFUL

SPEAR INDICATORS

GROUP No. 1

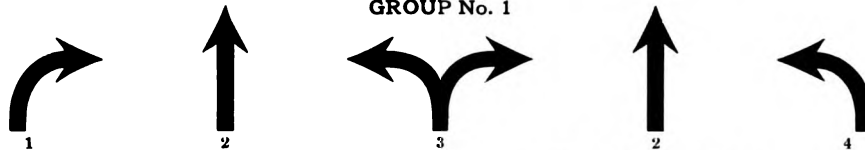

4 each Nos. 1, 3 and 4; 6 No. 2. Per font, \$1.25

Will justify perfectly to 6-point rule

GROUP No. 3

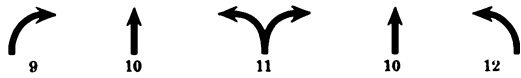

8 each Nos. 9 and 12; 12 No. 10; 4 No. 11 Per font, \$0.75
Will justify perfectly to 2-point rule

GROUP No. 2



6 each Nos. 5 and 8; 4 No. 7; 8 No. 6 Per font, \$1.00
Will justify perfectly to 4-point rule



Each, \$0.25; 6 for \$1.00

Will justify perfectly to 12-point rule

THE H. C. HANSEN TYPE FOUNDRY



AD. AND JOB BORDERS

WHEN ORDERING MENTION POINT AND NUMBER. DO NOT MUTILATE BOOK

6-POINT, 60 INCHES, \$1.50

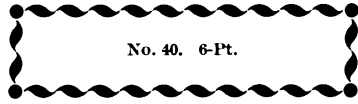

No. 40. 6-Pt.

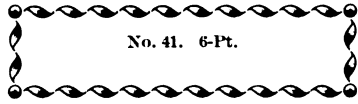

No. 41. 6-Pt.

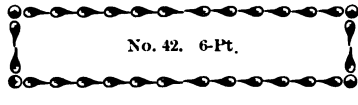

No. 42. 6-Pt.

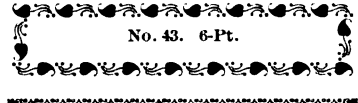

No. 43. 6-Pt.

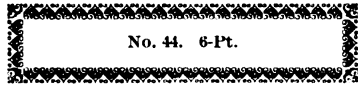

No. 44. 6-Pt.

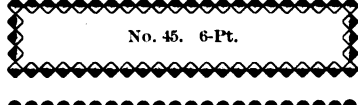

No. 45. 6-Pt.

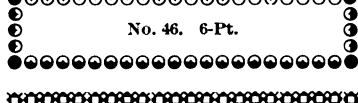

No. 46. 6-Pt.

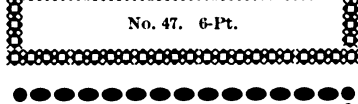

No. 47. 6-Pt.

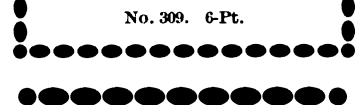

No. 309. 6-Pt.

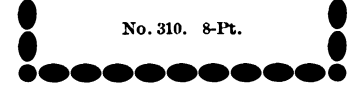

No. 310. 8-Pt.

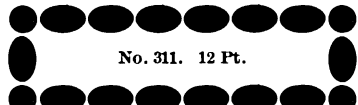

No. 311. 12 Pt.

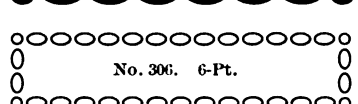

No. 306. 6-Pt.

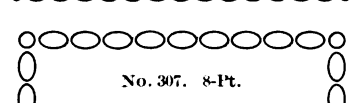

No. 307. 8-Pt.

8-POINT, 54 INCHES, \$1.35

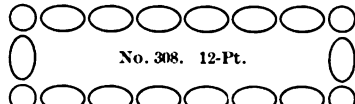

No. 308. 12-Pt.

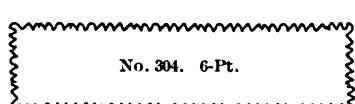

No. 304. 6-Pt.

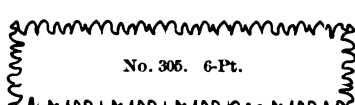

No. 305. 6-Pt.

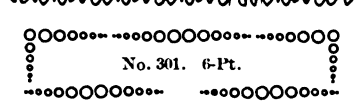

No. 301. 6-Pt.

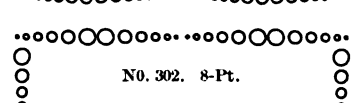

No. 302. 8-Pt.

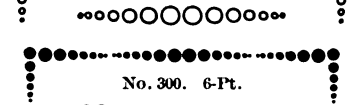

No. 300. 6-Pt.

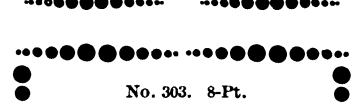

No. 303. 8-Pt.



No. 507. 6 Pt.

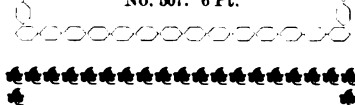

No. 200. 8-Pt.

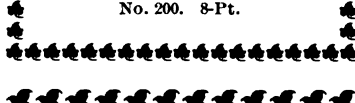

No. 201. 8-Pt.

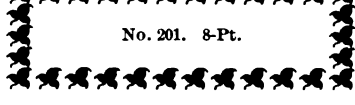

No. 198. 8-Pt.

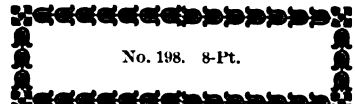

No. 199. 8-Pt.

12-POINT, 54 INCHES, \$1.50

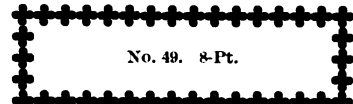

No. 49. 8-Pt.

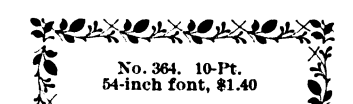

No. 364. 10-Pt.
54-inch font, \$1.40

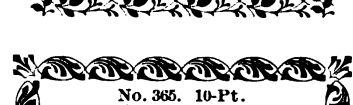

No. 365. 10-Pt.
54-inch font, \$1.40

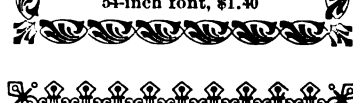

No. 134. 12-Pt.

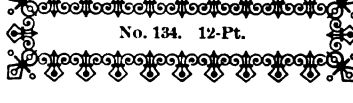

No. 160. 12-Pt.

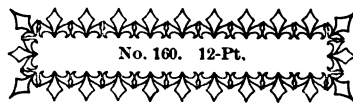

No. 135. 12-Pt.

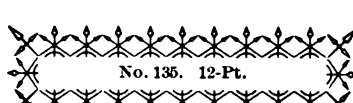

No. 132. 12-Pt.

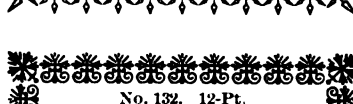

No. 136. 12-Pt.



No. 129. 12-Pt.

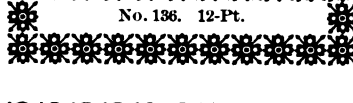

No. 130. 12-Pt.

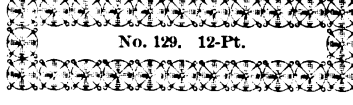

No. 152. 12-Pt.

THE H. C. HANSEN TYPE FOUNDRY



AD. AND JOB BORDERS

12-POINT, 54 INCHES, \$1.50

18-POINT, 36 INCHES, \$1.30

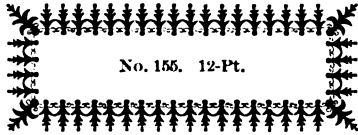

No. 155. 12-Pt.



No. 95. 12-Pt.



No. 98. 18-Pt.

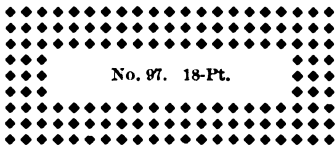

No. 97. 18-Pt.

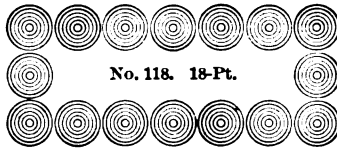

No. 118. 18-Pt.

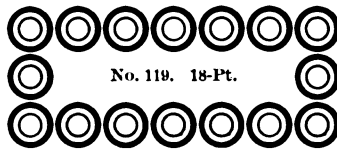

No. 119. 18-Pt.

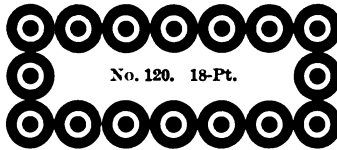

No. 120. 18-Pt.



Buffaloes. 24-Pt. 15c. 18-inch font, \$1.25

HUB ORNAMENTS

Each character in sets of four at 40c per set.

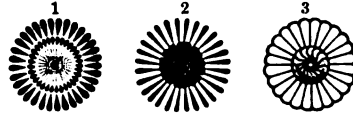

6-Pt. Commercial Border No. 2

60-inch font, \$1.50

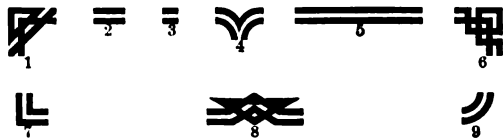

OUR 6-POINT RULE NO. 517 WILL MATCH THIS BORDER.

6-Pt. Commercial Border No. 1

60-inch font, \$1.75

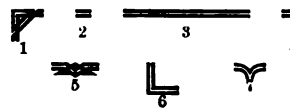

12-Pt. Commercial Border No. 3

54-inch font, \$1.75

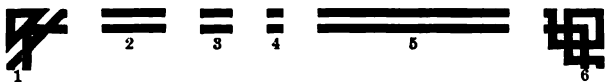

THE H. C. HANSEN TYPE FOUNDRY



MULTIPLEX BORDERS

FONT, 60 INCHES, 6-POINT, \$1.50

FONT, 54 INCHES, 8-POINT, \$1.35

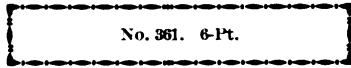

No. 361. 6-Pt.

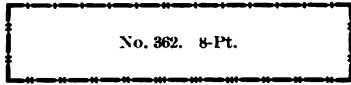

No. 362. 8-Pt.

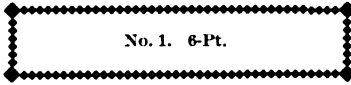

No. 1. 6-Pt.

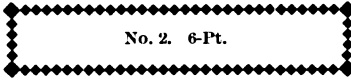

No. 2. 6-Pt.

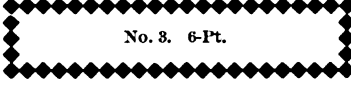

No. 3. 6-Pt.

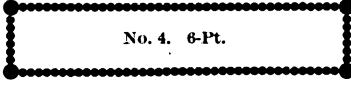

No. 4. 6-Pt.

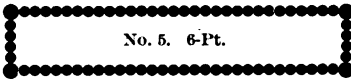

No. 5. 6-Pt.

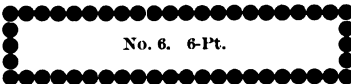

No. 6. 6-Pt.

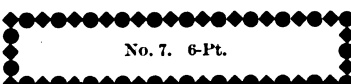

No. 7. 6-Pt.

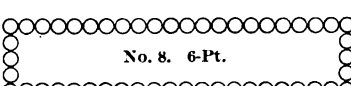

No. 8. 6-Pt.

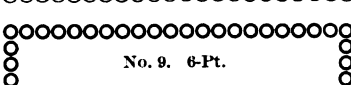

No. 9. 6-Pt.

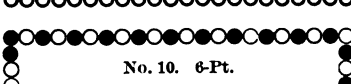

No. 10. 6-Pt.

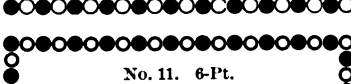

No. 11. 6-Pt.

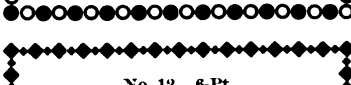

No. 12. 6-Pt.



No. 13. 6-Pt.

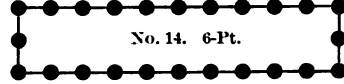

No. 14. 6-Pt.

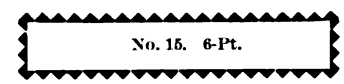

No. 15. 6-Pt.

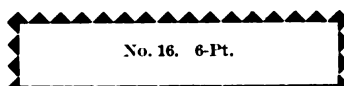

No. 16. 6-Pt.

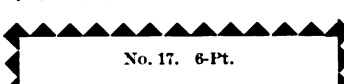

No. 17. 6-Pt.

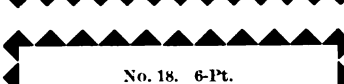

No. 18. 6-Pt.

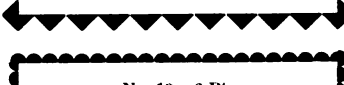

No. 19. 6-Pt.



No. 20. 6-Pt.

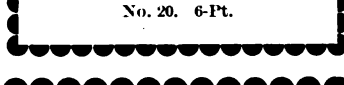

No. 21. 6-Pt.

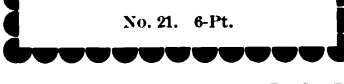

No. 22. 6-Pt.

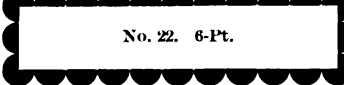

No. 23. 6-Pt.

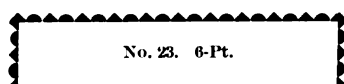

No. 24. 6-Pt.

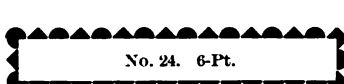

No. 25. 6-Pt.

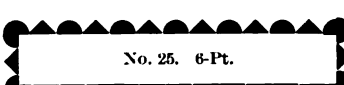

No. 26. 6-Pt.

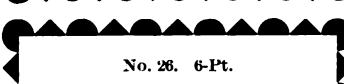

No. 27. 6-Pt.

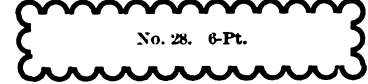

No. 28. 6-Pt.

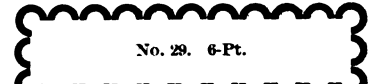

No. 29. 6-Pt.

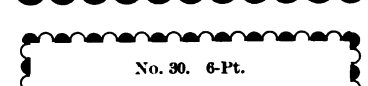

No. 30. 6-Pt.

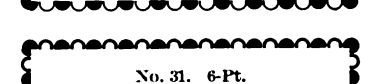

No. 31. 6-Pt.

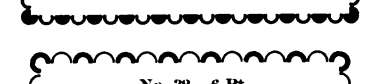

No. 32. 6-Pt.

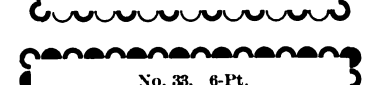

No. 33. 6-Pt.

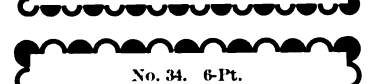

No. 34. 6-Pt.



No. 35. 6-Pt.



No. 36. 6-Pt.

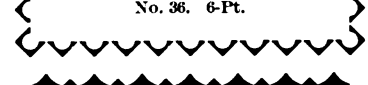

No. 37. 6-Pt.

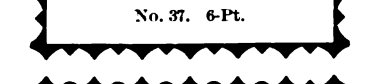

No. 38. 6-Pt.

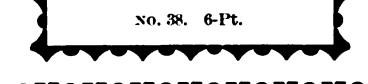

No. 39. 6-Pt.

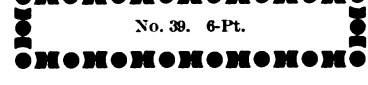

No. 51. 8-Pt.

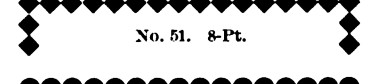

No. 52. 8-Pt.

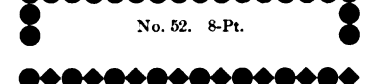

No. 53. 8-Pt.

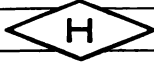

MULTIPLEX BORDERS

8-POINT, 54 INCHES, \$1.35

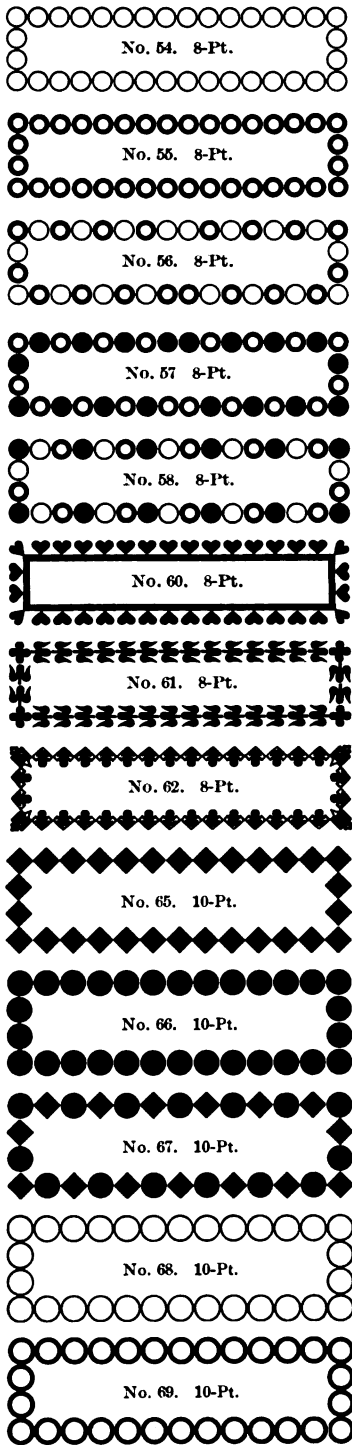

10-POINT, 54 INCHES, \$1.40

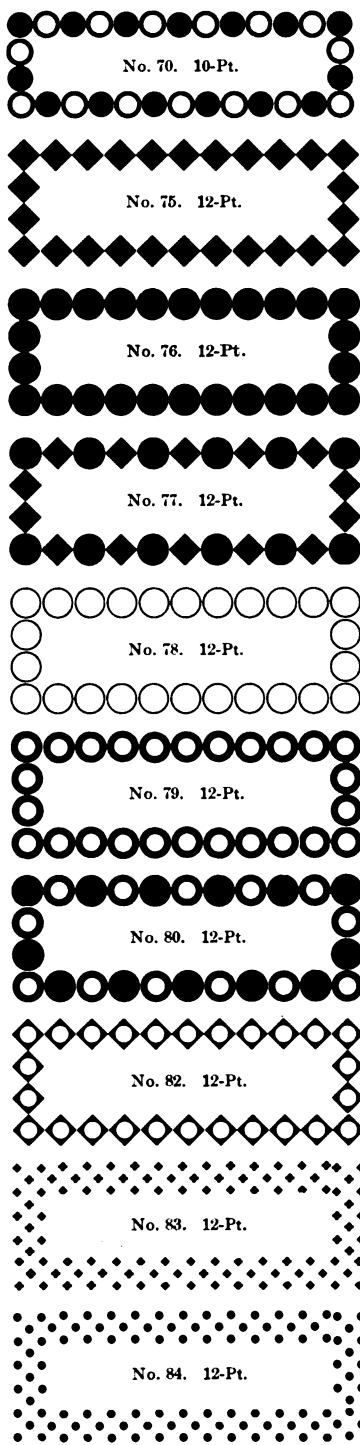

12-POINT, 54 INCHES, \$1.50

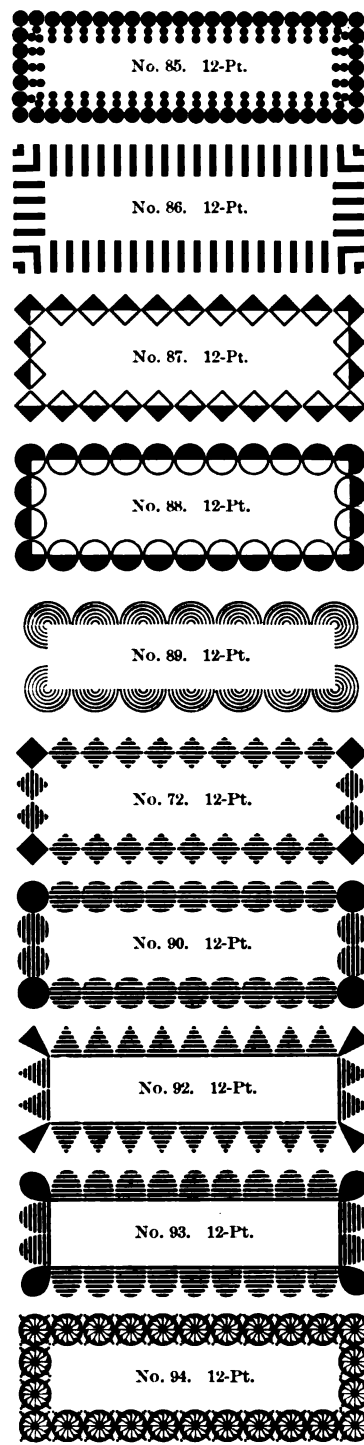

THE H. C. HANSEN TYPE FOUNDRY

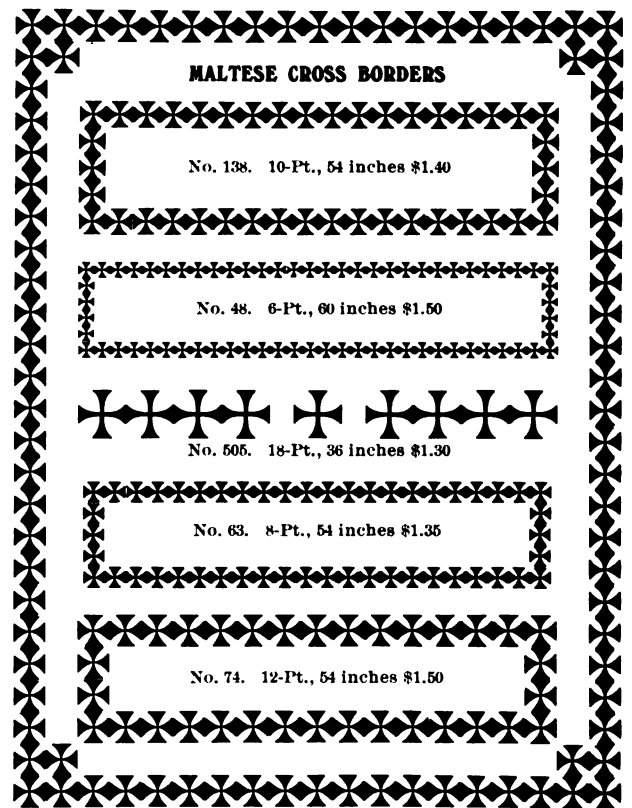
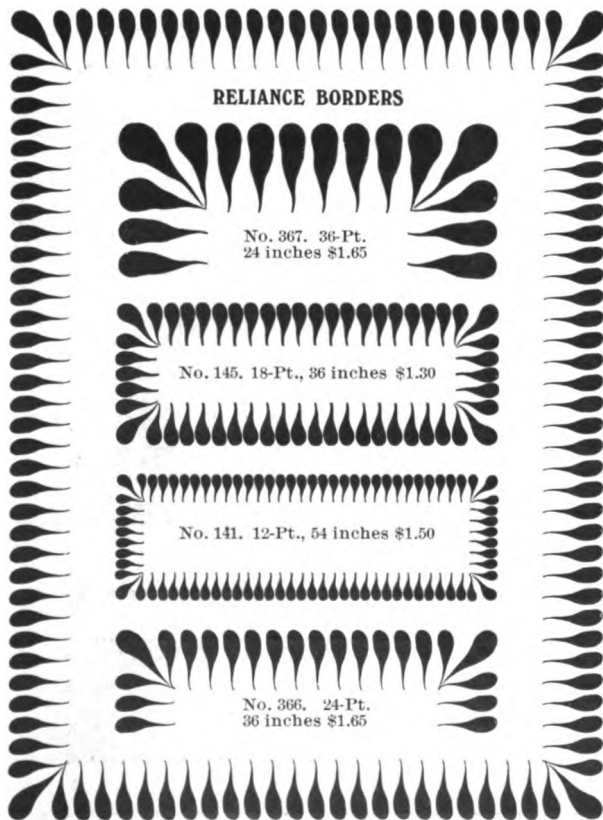
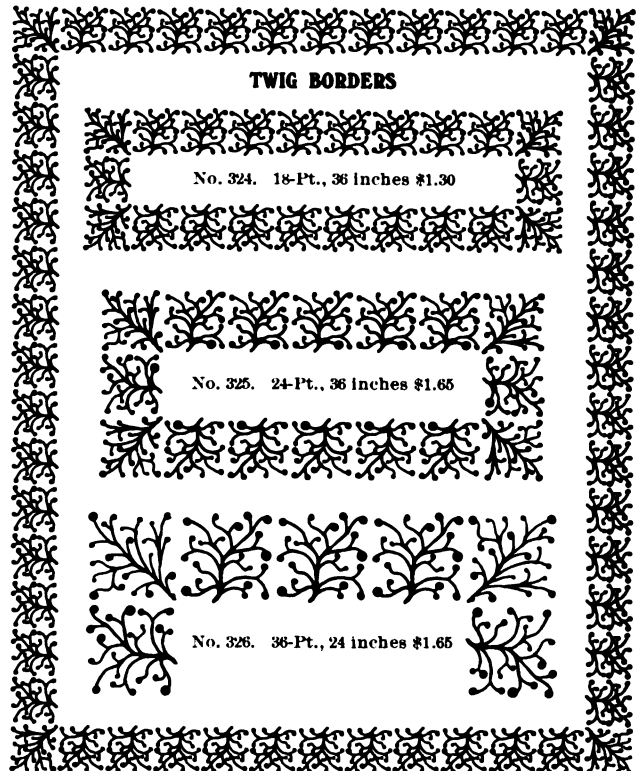
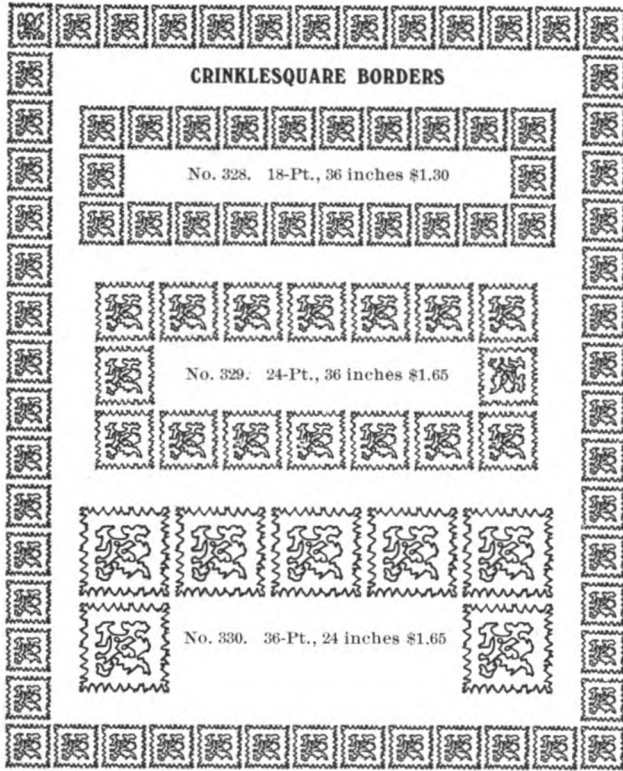

THE H. C. HANSEN TYPE FOUNDRY



AD. AND JOB BORDERS

12-POINT, 54 INCHES, \$1.50

18-POINT, 36 INCHES, \$1.30

24-POINT, 36 INCHES, \$1.65

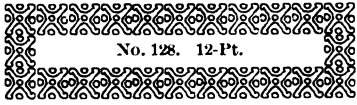

No. 128. 12-Pt.

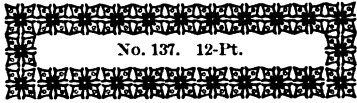

No. 137. 12-Pt.

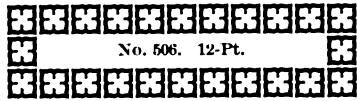

No. 506. 12-Pt.

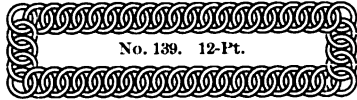

No. 139. 12-Pt.



No. 138. 12-Pt.

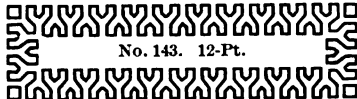

No. 143. 12-Pt.

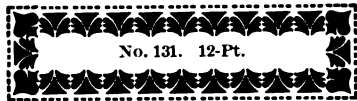

No. 131. 12-Pt.

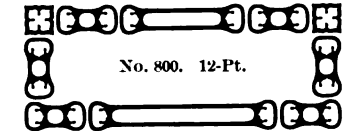

No. 800. 12-Pt.

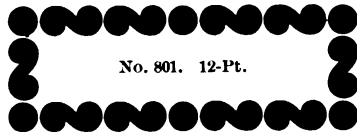

No. 801. 12-Pt.

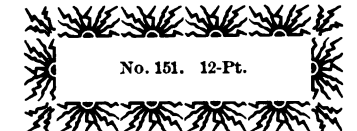

No. 151. 12-Pt.



No. 150. 24-Pt.

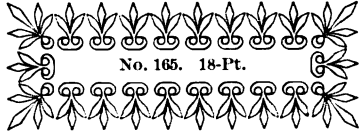

No. 165. 18-Pt.



No. 147. 18-Pt.

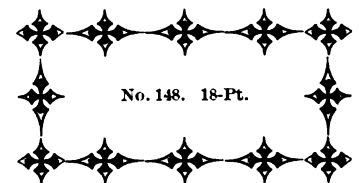

No. 148. 18-Pt.



No. 146. 18-Pt.



No. 149. 18-Pt.

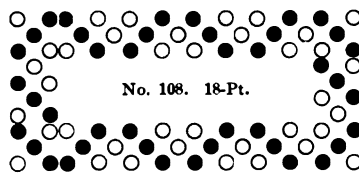

No. 108. 18-Pt.

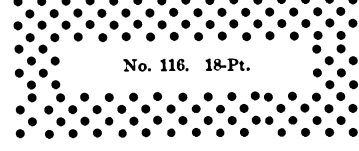

No. 116. 18-Pt.

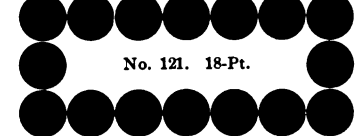

No. 121. 18-Pt.

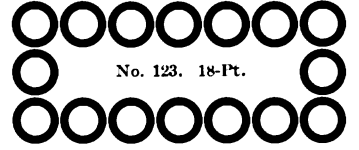

No. 123. 18-Pt.

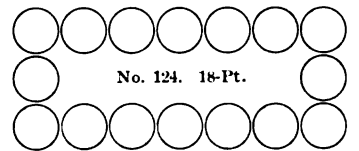

No. 124. 18-Pt.

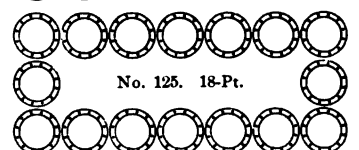

No. 125. 18-Pt.

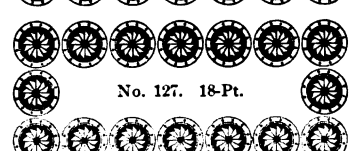

No. 127. 18-Pt.



Clover Leaf Border. 24-Pt.

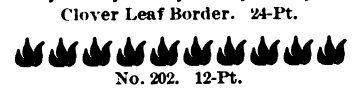

No. 202. 12-Pt.



No. 203. 12-Pt.

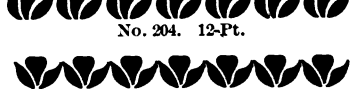

No. 204. 12-Pt.

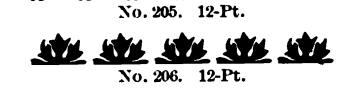

No. 205. 12-Pt.

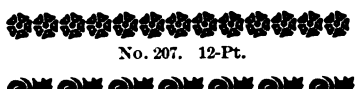

No. 206. 12-Pt.

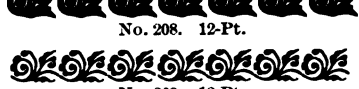

No. 207. 12-Pt.

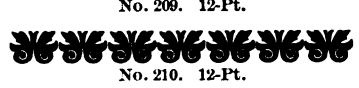

No. 208. 12-Pt.

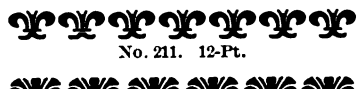

No. 209. 12-Pt.

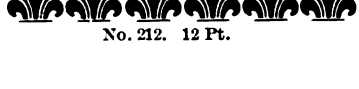

No. 210. 12-Pt.

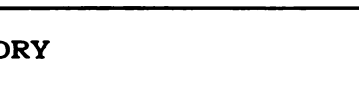

No. 211. 12-Pt.



No. 212. 12-Pt.

THE H. C. HANSEN TYPE FOUNDRY



CRINKLESQUARE BORDERS

No. 328. 18-Pt., 36 inches \$1.30

No. 329. 24-Pt., 36 inches \$1.65

No. 330. 36-Pt., 24 inches \$1.65

TWIG BORDERS

No. 324. 18-Pt., 36 inches \$1.30

No. 325. 24-Pt., 36 inches \$1.65

No. 326. 36-Pt., 24 inches \$1.65

RELIANCE BORDERS

No. 367. 36-Pt. 24 inches \$1.65

No. 145. 18-Pt., 36 inches \$1.30

No. 141. 12-Pt., 54 inches \$1.50

No. 366. 24-Pt. 36 inches \$1.65

MALTESE CROSS BORDERS

No. 138. 10-Pt., 54 inches \$1.40

No. 48. 6-Pt., 60 inches \$1.50

No. 505. 18-Pt., 36 inches \$1.30

No. 63. 8-Pt., 54 inches \$1.35

No. 74. 12-Pt., 54 inches \$1.50

THE H. C. HANSEN TYPE FOUNDRY



AD. AND JOB BORDERS

12-POINT, 54 INCHES, \$1.50

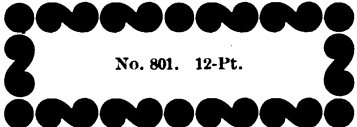
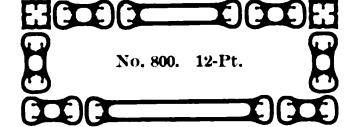
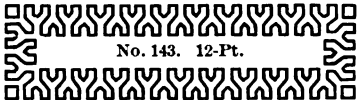
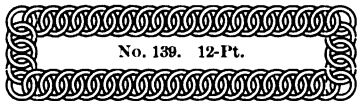
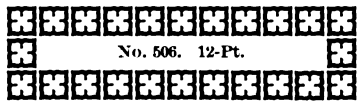
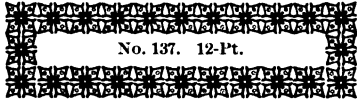
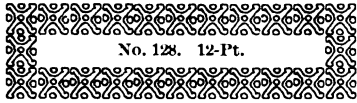

18-POINT, 36 INCHES, \$1.30

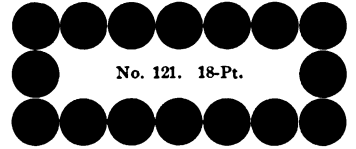
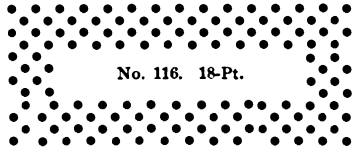
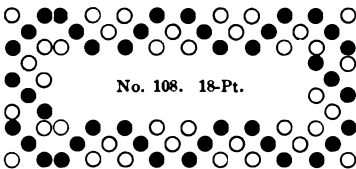
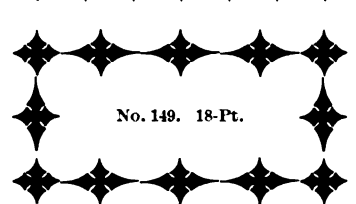

24-POINT, 36 INCHES, \$1.65

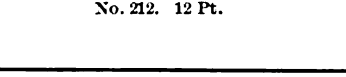
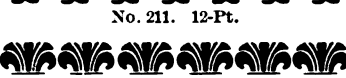
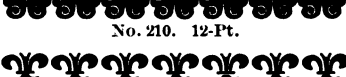
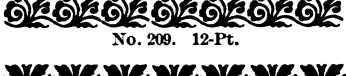
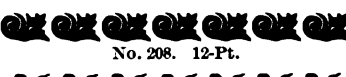
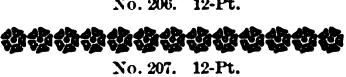
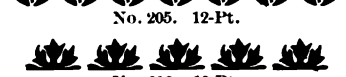
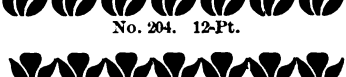
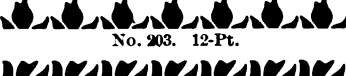
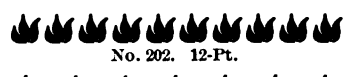
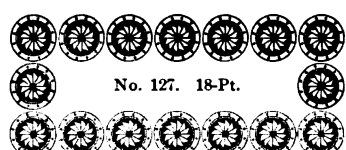
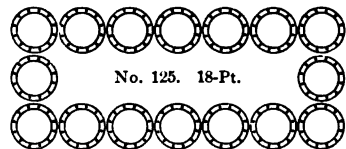
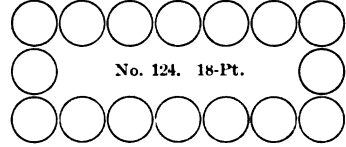

THE H. C. HANSEN TYPE FOUNDRY



TWIN BUFFALO BORDER No. 6
12-POINT
54 INCHES \$1.50

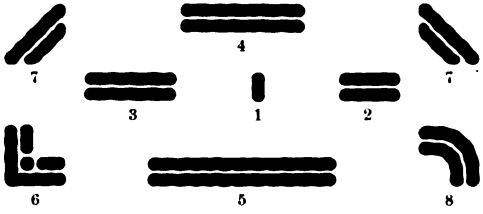

TWIN BUFFALO BORDER No. 7
6-POINT
60 INCHES \$1.50

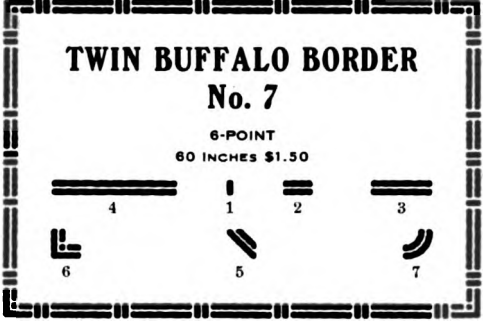

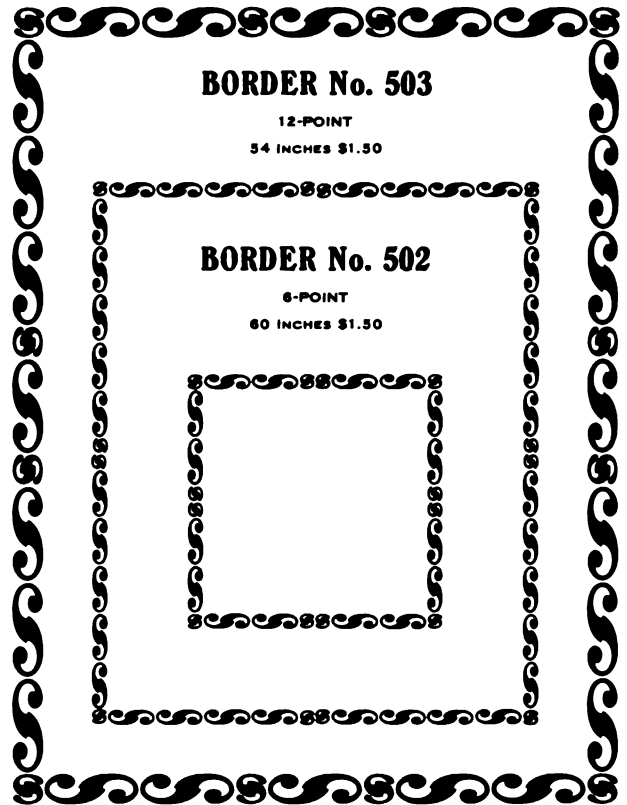

BORDER No. 503
12-POINT
54 INCHES \$1.50

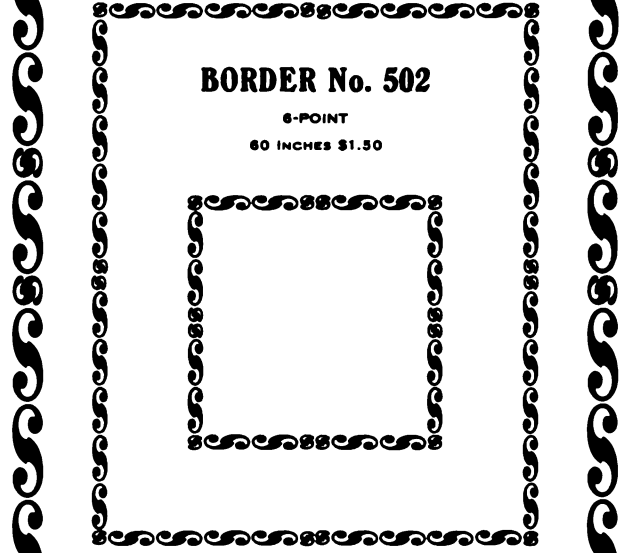

BORDER No. 502
6-POINT
60 INCHES \$1.50



BUFFALO BORDER No. 2
Price per font \$3.50

BUFFALO BORDER No. 1
Price per font \$3.00

THE H. C. HANSEN TYPE FOUNDRY

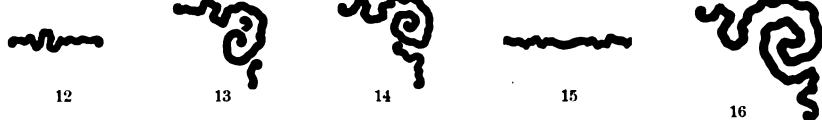

Hansen's Campaign Ornaments

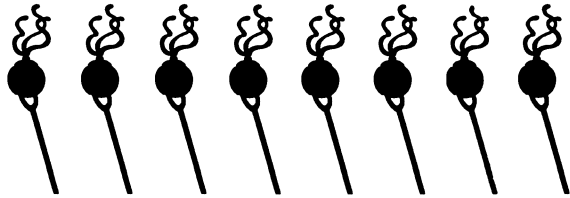

72-Point Campaign Ornament No. 1, 6-inch font, \$1.20
Contains 18 characters Individual character, 20 cents

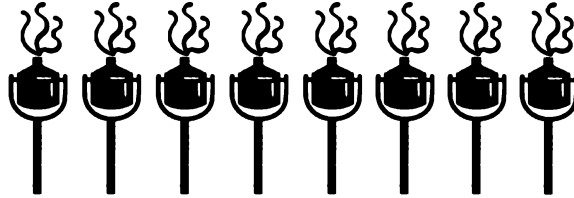

72-Point Campaign Ornament No. 2, 6-inch font, \$1.20
Contains 18 characters Individual character, 20 cents

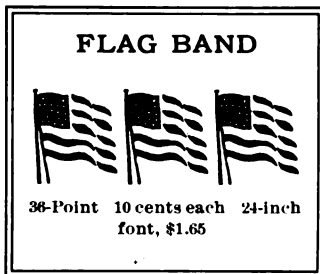

36-Point 10 cents each 24-inch font, \$1.65

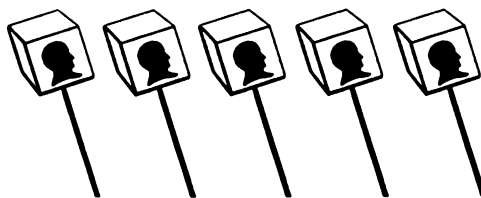

72-Point Campaign Ornament No. 3, 6-inch font, \$1.20
Contains 12 characters Individual character, 25 cents
Assorted font of Campaign Ornaments, 6-in. font, \$1.20
Contains 6 each of Nos. 1 and 2, and 4 of No. 3

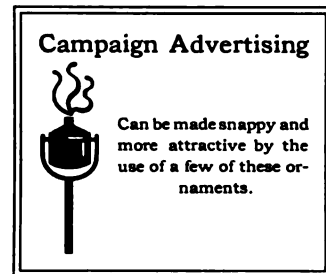

Stratford Old Style Ornaments



48-Point 18 inches \$1.50



36-Point 24 inches \$1.65



30-Point 24 inches \$1.35



24-Point 36 inches \$1.65

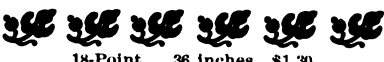

18-Point 36 inches \$1.30



12-Point 54 inches \$1.50

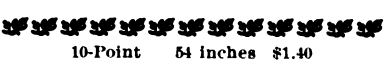

10-Point 54 inches \$1.40

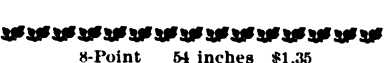

8-Point 54 inches \$1.35

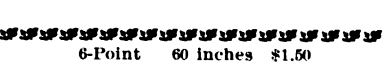

6-Point 60 inches \$1.50

Buffalo Italic Ornaments No. 1



48-Point 18 inches \$1.50



36-Point 24 inches \$1.65



30-Point 24 inches \$1.30



24-Point 36 inches \$1.65



18-Point 36 inches \$1.30

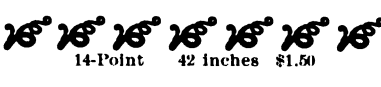

14-Point 42 inches \$1.50



12-Point 54 inches \$1.50



10-Point 54 inches \$1.40

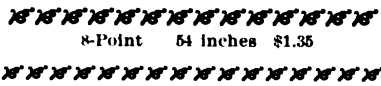

8-Point 54 inches \$1.35

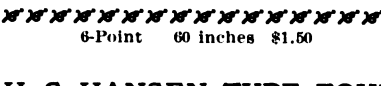

6-Point 60 inches \$1.50

Buffalo Italic Ornaments No. 2



48-Point 18 inches \$1.50



36-Point 24 inches \$1.65



30-Point 24 inches \$1.35

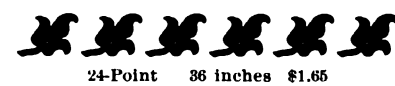

24-Point 36 inches \$1.65

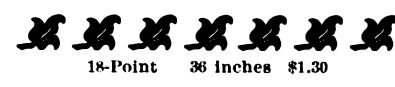

18-Point 36 inches \$1.30

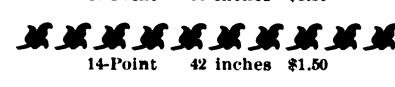

14-Point 42 inches \$1.50

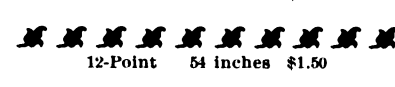

12-Point 54 inches \$1.50

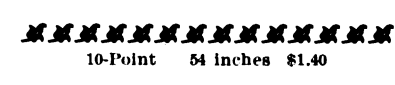

10-Point 54 inches \$1.40

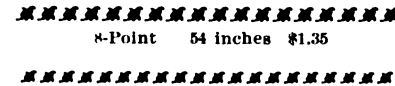

8-Point 54 inches \$1.35

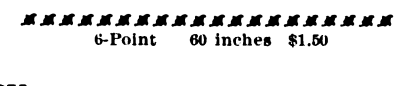

6-Point 60 inches \$1.50

THE H. C. HANSEN TYPE FOUNDRY

Marguerite Borders

No. 161 6-Point 60-inch font \$1.50

No. 166 6-Point 60-inch font \$1.50

No. 162 9-Point 54-inch font \$1.40

No. 163 12-Point 54-inch font \$1.50

No. 167 9-Point 54-inch font \$1.40

No. 164 18-Point 36-inch font \$1.30

Buffalo and Buffalo Outline Ornaments

<p>6-Point 60 inches, \$1.50</p> <p>8-Point 54 inches, \$1.35</p> <p>10-Point 54 inches, \$1.40</p> <p>12-Point 54 inches, \$1.50</p> <p>12-Point 54 inches, \$1.50</p> <p>14-Point 42 inches, \$1.50</p> <p>14-Point 42 inches, \$1.50</p> <p>18-Point 36 inches, \$1.30</p> <p>24-Point 36 inches, \$1.65</p>	<p>30-Point 24 inches, \$1.35</p> <p>36-Point 24 inches, \$1.65</p> <p>48-Point 18 inches, \$1.50</p> <p>60-Point 12 inches, \$1.35 72-Point 12 inches, \$1.35</p>	
---	---	--

In ordering please specify whether outline or black is desired

THE H. C. HANSEN TYPE FOUNDRY



Laurel Borders

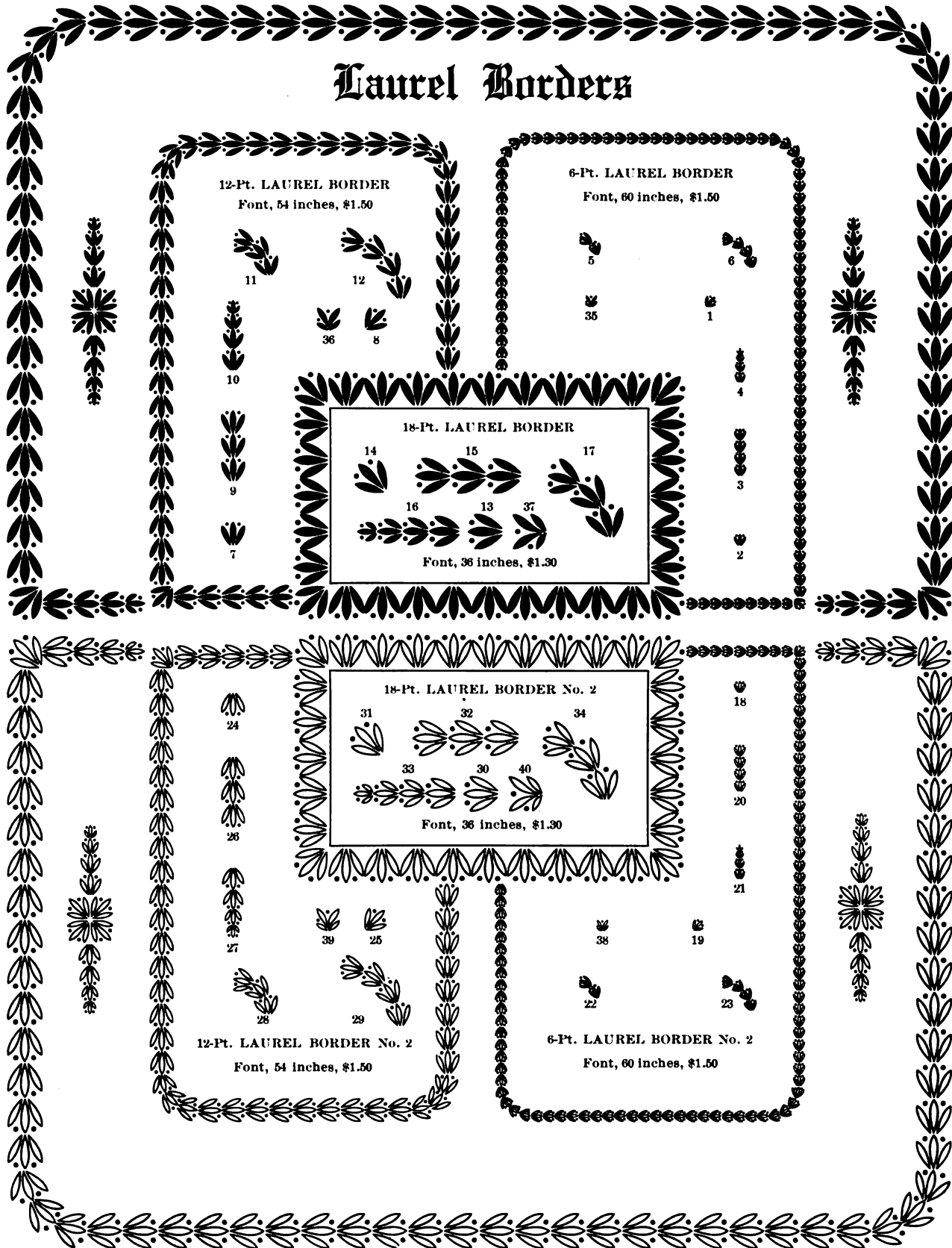

THE H. C. HANSEN TYPE FOUNDRY



Swastika Ornaments

Originated in Type by The H. C. Hansen Type Foundry



72-Point No. 18



48-Point No. 16

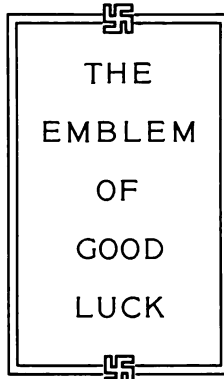

THE
EMBLEM
OF
GOOD
LUCK

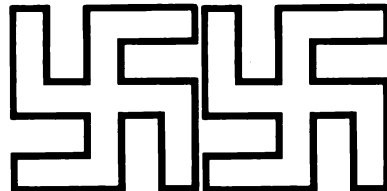

72-Point No. 17

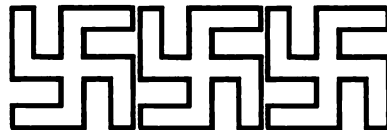

48-Point No. 15



36-Point No. 14



24-Point No. 12



18-Point No. 10



12-Point No. 8



10-Point No. 6



8-Point No. 4



6-Point No. 2

HISTORY OF "SWASTIKA"

THE word "Swastika" is derived from the Sanscrit, meaning good fortune, well being, welfare. It is the oldest known symbol in the world, and is found in pre-historic graves and ruins in all quarters of the globe. In India, where it probably originated, it is found in the mountains carved upon solid rock, while in Arizona it is painted upon walls of the canons. The Ancient Greeks, Cliff Dwellers of North America and Brazilians adopted it for their pottery. Throughout China and Japan it is used as a sign of long life, good wishes and good fortune. The Buddhists regard it as the seal of Buddha's heart; and right here in America at the present time some of our Indians employ it as a sacred symbol. The Navajos weave it into their blankets and manufacture it from silver. It is much used on Jewelry, China, Embroidery, Post Cards, etc.

FONT PRICES. Order by Number

72-Pt. 12-inch font, \$1.35	18-Pt. 36-inch font, \$1.30
48-Pt. 18-inch font, 1.50	12-Pt. 54-inch font, 1.50
36-Pt. 24-inch font, 1.65	10-Pt. 54-inch font, 1.40
24-Pt. 36-inch font, 1.65	8-Pt. 54-inch font, 1.35
6-Pt. 60-inch font, \$1.50	

Single Characters: 72-Pt. 35c., 48-Pt. 20c., 36-Pt. 15c.

ASSORTED FONT, \$2.00

Containing of each color: 72-Pt. 1 each; 48-Pt. 2 each; 36-Pt. 2 each; 24-Pt. 4 each; 18-Pt. 8 each; 12-Pt., 10-Pt., 8-Pt. and 6-Pt., 12 each.



36-Point No. 13



24-Point No. 11



18-Point No. 9



12-Point No. 7



10-Point No. 5



8-Point No. 3



6-Pt. No. 1

THE H. C. HANSEN TYPE FOUNDRY



Aleppo Border and Ornaments

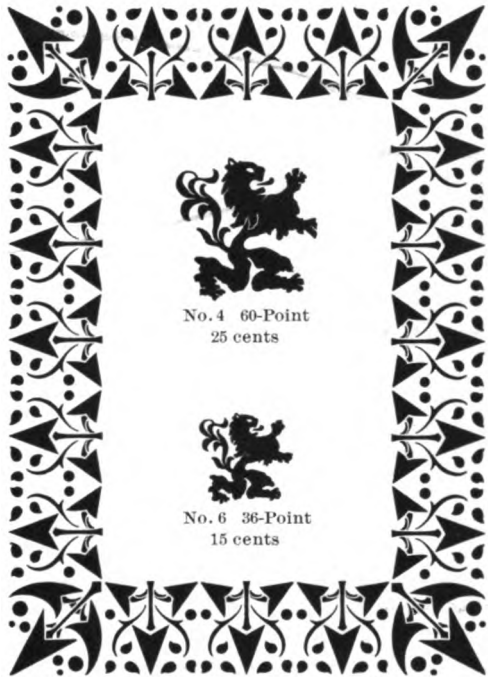

36-Point Aleppo Border 24-inch font, \$1.65



No. 4 60-Point 25 cents



No. 6 36-Point 15 cents



No. 3 72-Pt. 40 cents



No. 706 120-Point 45 cents



No. 2 36-Point 10 cents each 24-inch font, \$1.65



No. 5 60-Point 25 cents



No. 1 36-Point 10c each

24-inch font, \$1.65

WORD ORNAMENTS

Font, containing 3 of each character from 6-Pt. to 12-Pt., 2 each from 14-Pt. to 24-Pt., and 1 each from 30-Pt. to 48-Pt. \$1.50

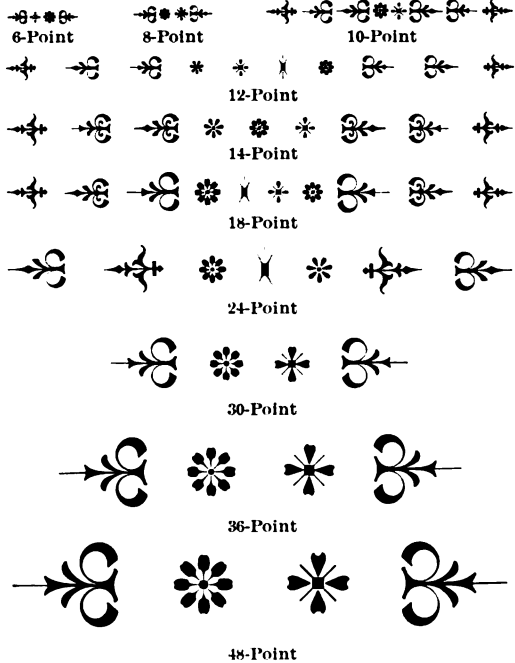

HANSEN ORNAMENTS

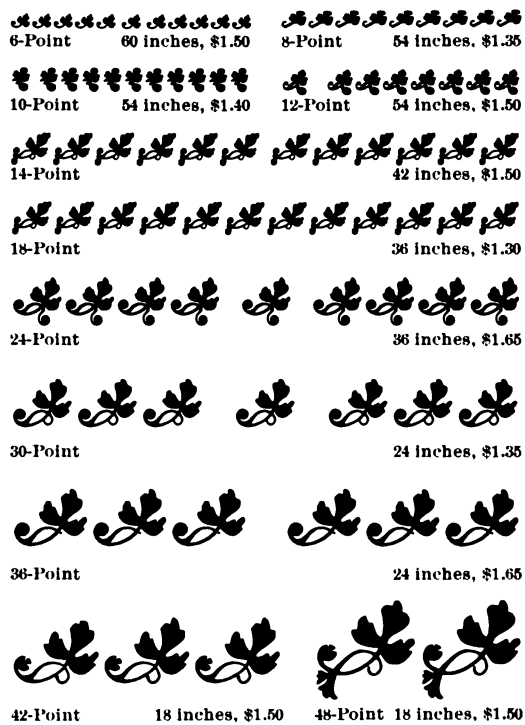

THE H. C. HANSEN TYPE FOUNDRY



The "Teddy Bear" Ornaments

THE jolly little Teddy Bears, shown herewith, offer a new and interesting group of up-to-date type embellishments which will brighten and add to the attractiveness of many a bit of printing. Their uses are many and varied. Made in two styles and in three sizes each, they are proving very popular.

PRICES
 24-Point, 10c each. 18-inch font, \$1.75 48-Point, 20c each. 12-inch font. \$1.75
 72-Point, 35c each

ASSORTED FONT, \$2.50
 Containing 2 each 72-Point, 3 each 48-Point, 6 each 24-Point (22 characters in all)

72-Pt. No. 1 48-Pt. No. 4 24-Pt. No. 5 24-Pt. No. 6 48-Pt. No. 3 72-Pt. No. 2

Fleur-de-Lis Borders and Ornaments

No. 3390. 24-Point. 36-inch font \$1.65 No. 3380. 24-Point. 36-inch font \$1.65

No. 1970. 12-Point 54-inch font \$1.50 No. 1900. 12-Point 54-inch font \$1.50

No. 337. 18-Point. 36-inch font \$1.30

No. 3600. 48-Point. 18 inches \$1.50 No. 3420. 48-Point. 18 inches \$1.50
 Single characters, 10 cents each

No. 336. 18-Point. 36-inch font \$1.30 No. 3410. 36-Point. 24 inches \$1.65 No. 3400. 36-Point. 24 inches \$1.65

THE H. C. HANSEN TYPE FOUNDRY

Educators



**The H. C. Hansen
Type Foundry**

Educators

THE above name applied to the series of Borders and Tint Formers, shown herein, may, at first glance, seem rather pretentious,—but, let the person who doubts that there is anything educational in the use of these simple little characters procure the series and undertake to find the limit to the attractive combinations in which they can be used, they will find a profitable surprise in store for them, or—well, if not, their perceptive faculties must be so sadly dimmed that their case is nearly hopeless.

For borders, backgrounds or initials they can be quickly set to *fit any space*, and the variety of combinations that may be secured with the various sizes is almost unlimited.

**The H. C. Hansen
Type Foundry**

Boston

New York



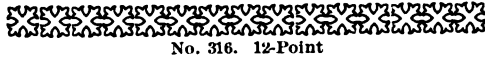
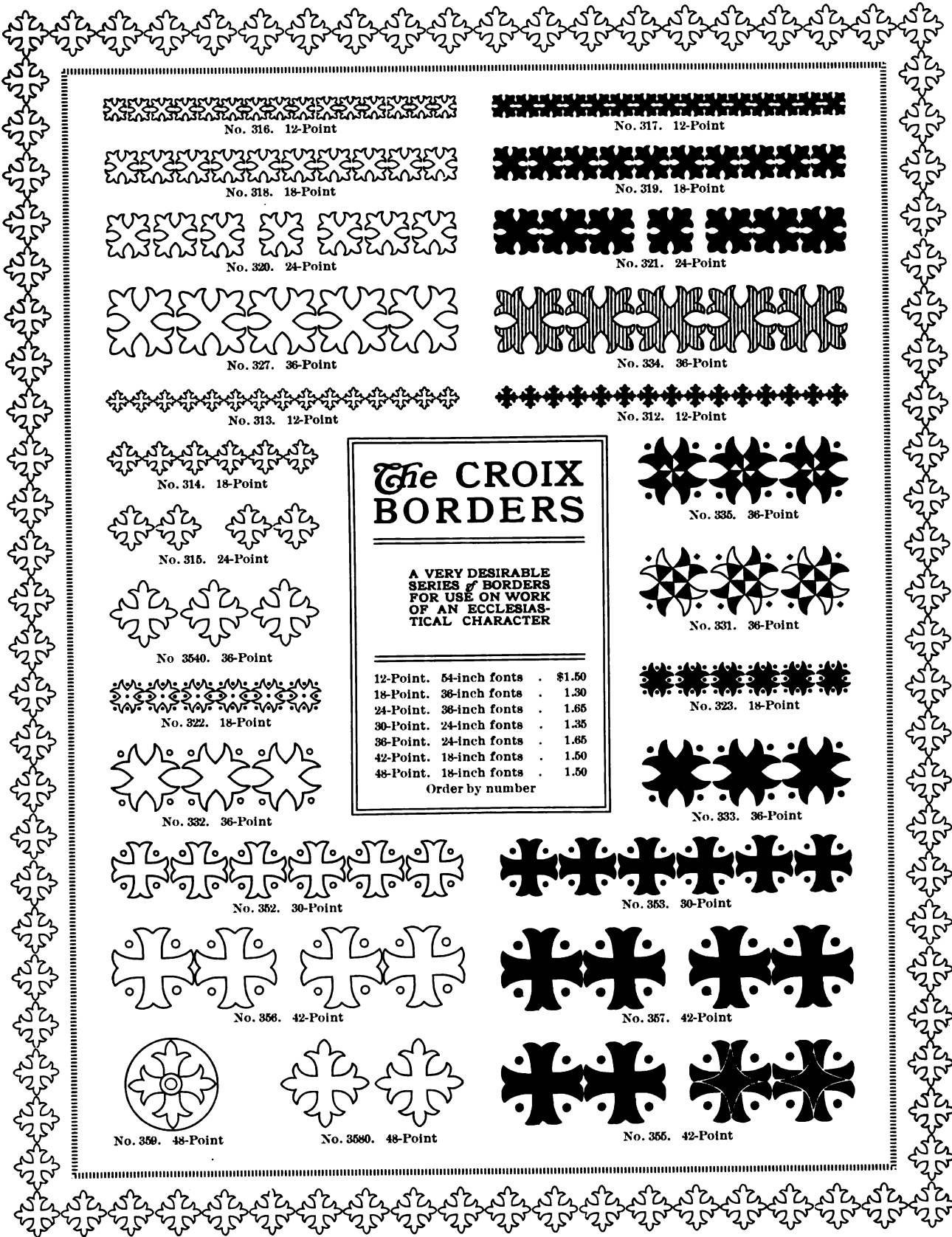

No. 316. 12-Point

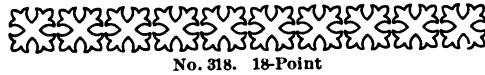

No. 318. 18-Point

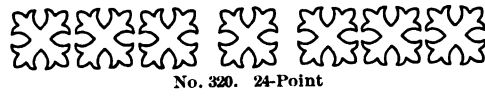

No. 320. 24-Point

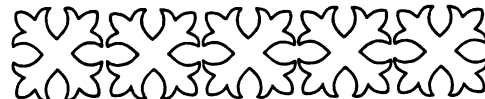

No. 327. 36-Point

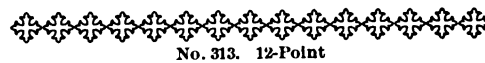

No. 313. 12-Point

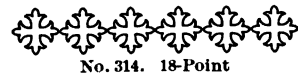

No. 314. 18-Point

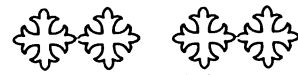

No. 315. 24-Point

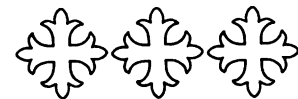

No. 3540. 36-Point

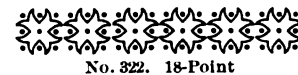

No. 322. 18-Point



No. 332. 36-Point

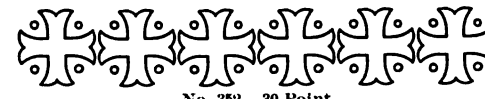

No. 352. 30-Point

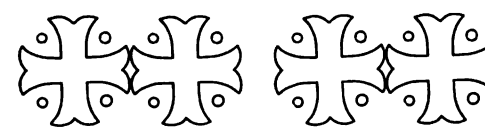

No. 356. 42-Point

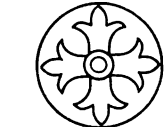

No. 359. 48-Point

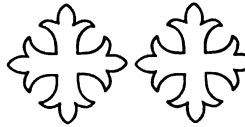

No. 3580. 48-Point

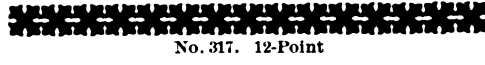

No. 317. 12-Point



No. 319. 18-Point



No. 321. 24-Point



No. 334. 36-Point

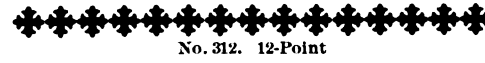

No. 312. 12-Point

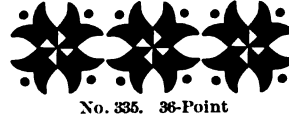

No. 335. 36-Point



No. 331. 36-Point

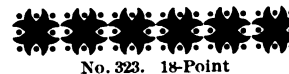

No. 323. 18-Point



No. 333. 36-Point



No. 353. 30-Point

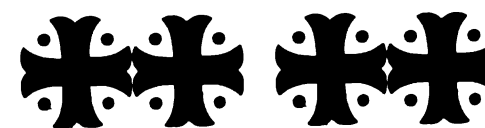

No. 357. 42-Point



No. 355. 42-Point

The CROIX BORDERS

A VERY DESIRABLE SERIES OF BORDERS FOR USE ON WORK OF AN ECCLESIASTICAL CHARACTER

12-Point. 64-inch fonts	. \$1.50
18-Point. 36-inch fonts	. 1.30
24-Point. 36-inch fonts	. 1.65
30-Point. 24-inch fonts	. 1.35
36-Point. 24-inch fonts	. 1.65
42-Point. 18-inch fonts	. 1.50
48-Point. 18-inch fonts	. 1.50

Order by number



HANSEN'S SYLPH BORDERS

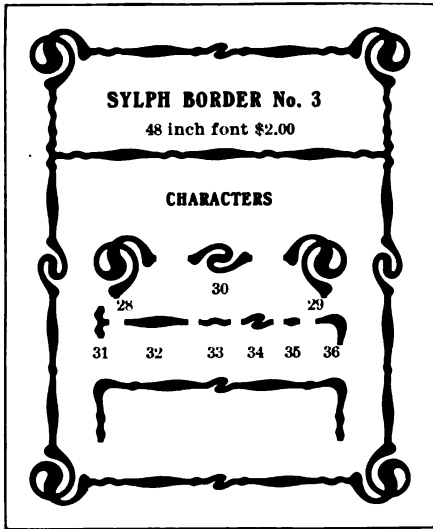

These Borders are designed to please and satisfy every discerning printer

The above panel set with Hansen's Beveled Quotations and Quads. Send for circular.

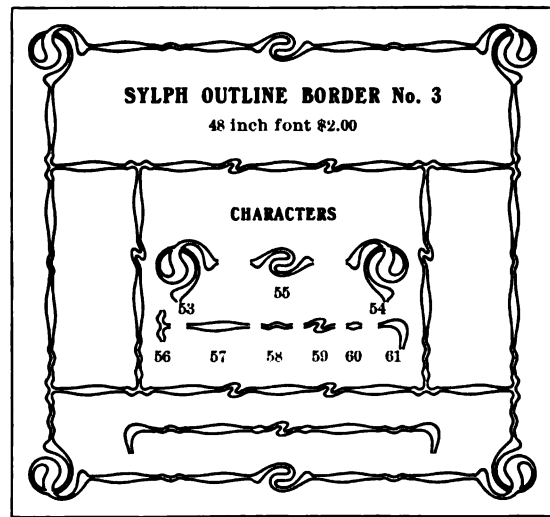
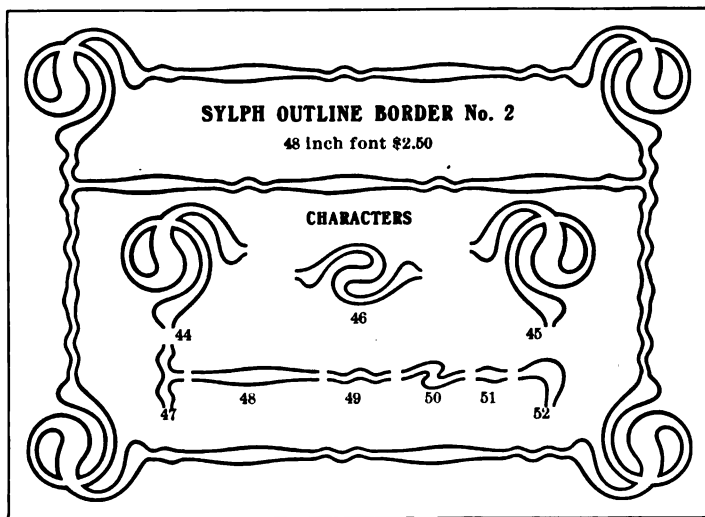
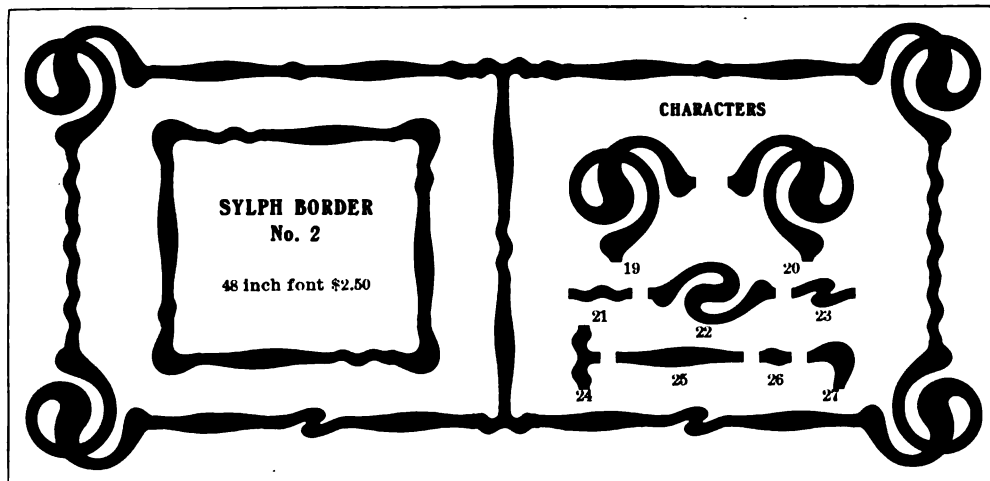
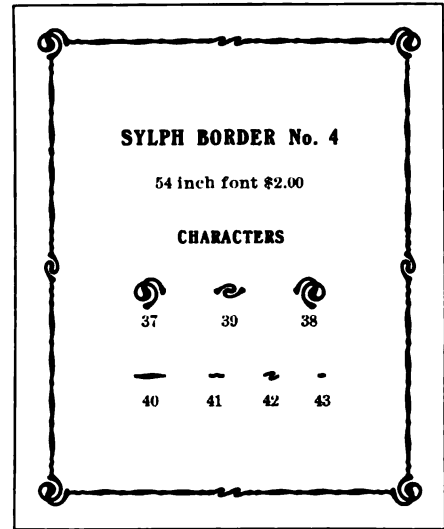

THE H. C. HANSEN TYPE FOUNDRY



HANSEN'S 18-PT. SYLPH BORDER No. 1

An artistic border for advertising and jobwork

Font containing 60 inches \$3.00

Characters of the Sylph Border

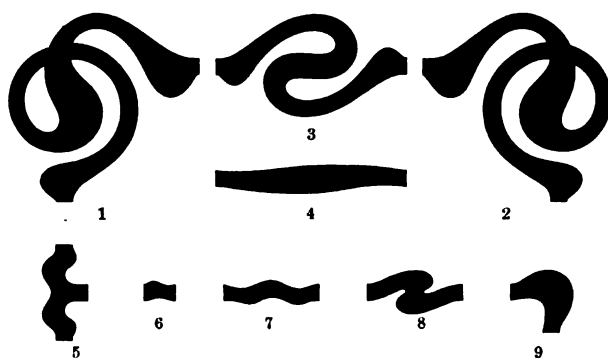

Characters of the Sylph Outline Border

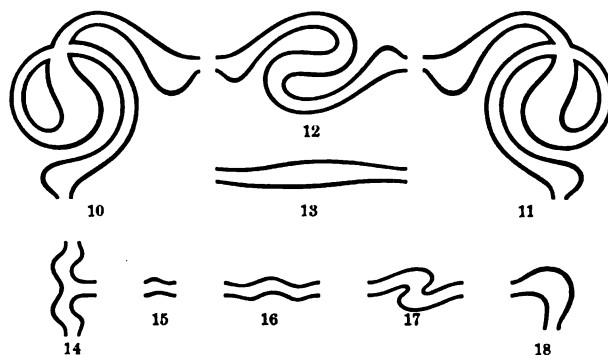

Hansen's 18-Pt. Sylph Outline Border No. 1

Can be used with the 18-Pt. Sylph Border for two-color work, if desired

Font containing 60 inches \$3.00

THE H. C. HANSEN TYPE FOUNDRY

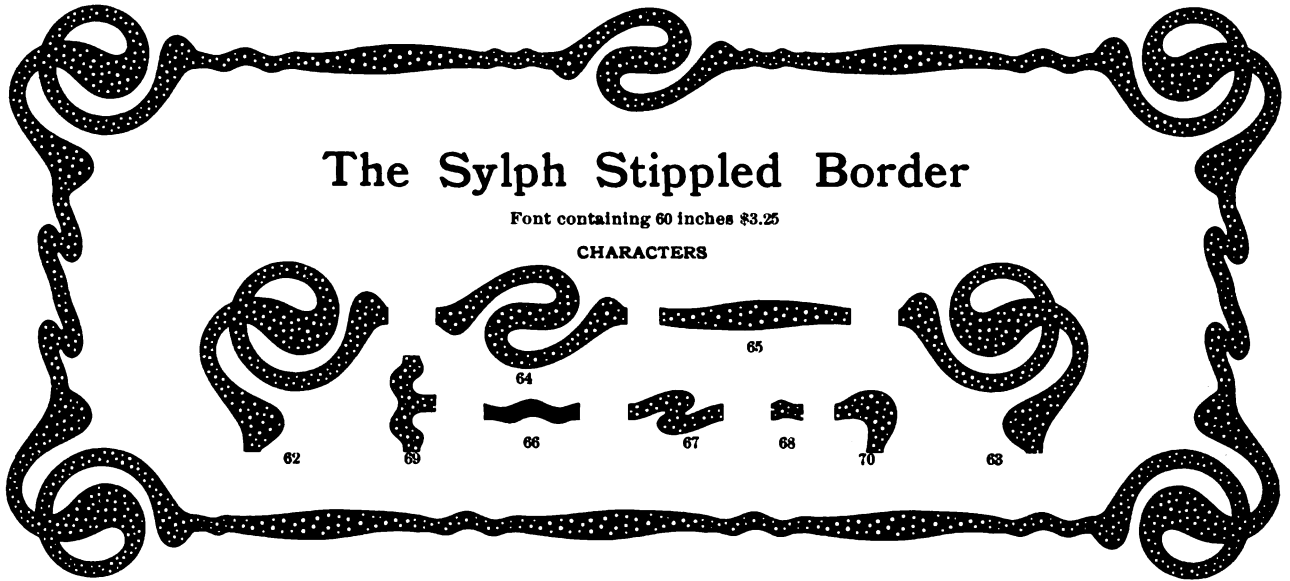

The Sylph Stippled Border

Font containing 60 inches \$3.25

CHARACTERS

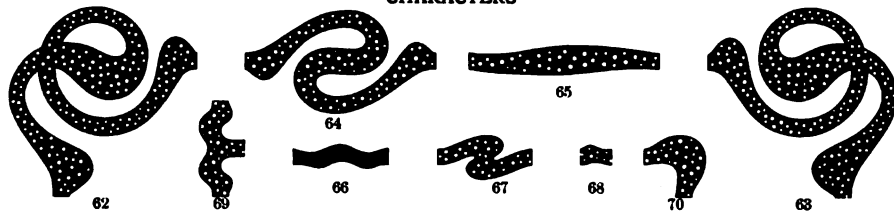

Bellman Borders



48-Pt. 18 inch font \$1.50



24-Pt. 36 inch font \$1.65



36-Pt. 24 inch font \$1.65



18-Pt. 36 inch font \$1.30



12-Pt. 54 inch font \$1.50

Waverley Bands

BANDS *and* BORDERS

THE VERY LATEST AND
BEST DESIGNS ARE MADE
BY THE H. C. HANSEN
TYPE FOUNDRY AT 190-192
CONGRESS ST., BOSTON

New York Branch, 43 Centre St.



No. 153C 48-Pt. 18 inch font \$1.50



No. 153 30-Pt. 24 inch font \$1.35



No. 153B 24-Pt. 36 inch font \$1.65



No. 153A 18-Pt. 36 inch font \$1.30

THE H. C. HANSEN TYPE FOUNDRY



**Holly Borders and
Ornaments**

**Made in Five
Styles**

8-Pt. Holly Border
One Color, 60-inch font, \$1.75.
Two Colors, 60-inch font, 30 inches
in each color, \$1.75

12-Pt. Holly Border
One Color, 64-inch font, \$1.50. Two Colors,
54-inch font, 27 inches in each color, \$1.50

36-Pt. Holly Border No. 4, One Color, 36-inch font, \$2.50
Two Colors, 36-inch font, 18 inches in each color, \$2.50

**Indispensable for
Holiday Work**

**Christmas
Banquets**



Barstow
The Caterer

72-Pt. Holly Wreath No. 2, One Color
45c; Two Colors, 90c

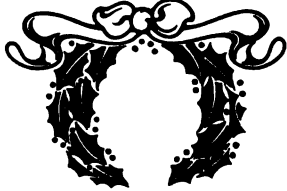

24-Pt. Holly Border No. 2, One Color,
36-inch font, \$2.00. Two Colors,
36-inch font, 18 inches in
each color, \$2.00

36-Pt. Holly Border No. 3, One Color, 36-inch
font, \$2.50. Two Colors, 36-inch font,
18 inches in each color, \$2.50
72-Pt. Holly Wreath, One Color, 40c; Two Colors, 80c

36-Pt. Holly Border No. 1, One Color, 24-inch
font, \$1.65. Two Colors, 24-inch font,
12 inches in each color, \$1.65

THE H. C. HANSEN TYPE FOUNDRY

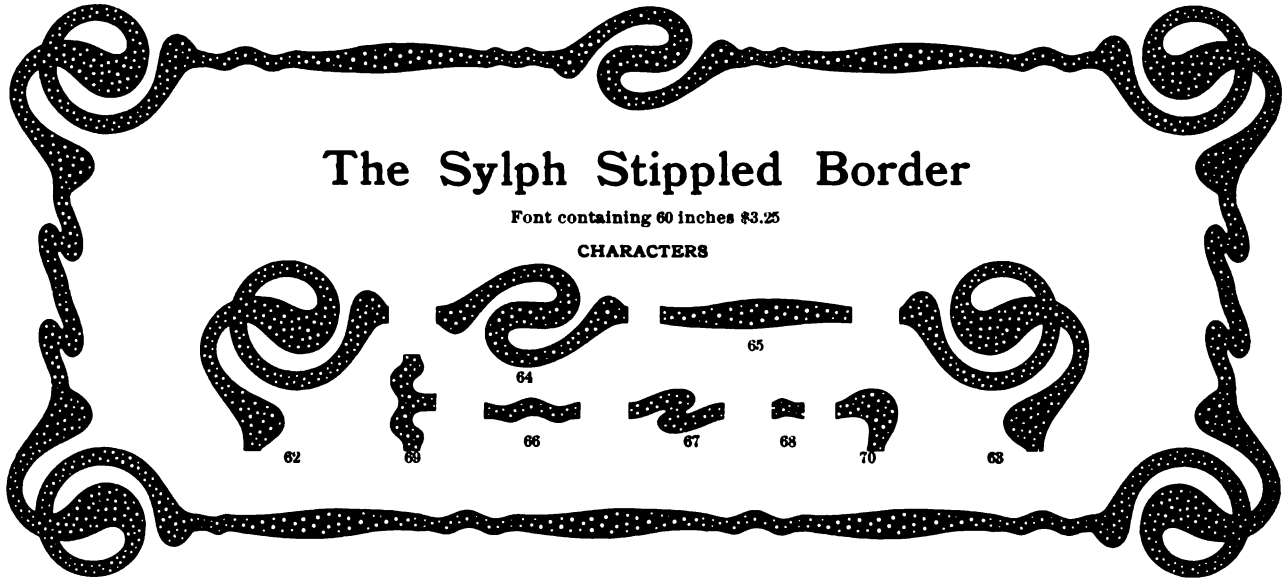

The Sylph Stippled Border

Font containing 60 inches \$3.25

CHARACTERS

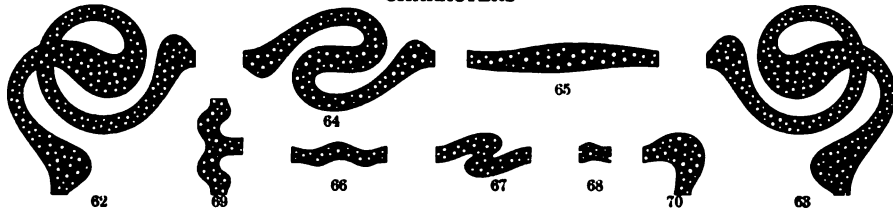

Bellman Borders



48-Pt. 18 inch font \$1.50



24-Pt. 36 inch font \$1.65



36-Pt. 24 inch font \$1.65



18-Pt. 36 inch font \$1.30



12-Pt. 54 inch font \$1.50

Waverley Bands

BANDS & BORDERS

THE VERY LATEST AND
BEST DESIGNS ARE MADE
BY THE H. C. HANSEN
TYPE FOUNDRY AT 190-192
CONGRESS ST., BOSTON

New York Branch, 43 Centre St.



No. 153C 48-Pt. 18 inch font \$1.50



No. 153 30-Pt. 24 inch font \$1.35



No. 153B 24-Pt. 36 inch font \$1.65



No. 153A 18-Pt. 36 inch font \$1.30

THE H. C. HANSEN TYPE FOUNDRY



Holly Borders and Ornaments

Made in Five Styles

6-Pt. Holly Border
One Color, 60-inch font, \$1.75.
Two Colors, 60-inch font, 30 inches in each color, \$1.75

12-Pt. Holly Border
One Color, 54-inch font, \$1.50. Two Colors, 54-inch font, 27 inches in each color, \$1.50

36-Pt. Holly Border No. 4, One Color, 36-inch font, \$2.50
Two Colors, 36-inch font, 18 inches in each color, \$2.50

Indispensable for
Holiday Work

Christmas Banquets



Barstow
The Caterer

72-Pt. Holly Wreath No. 2, One Color 45c; Two Colors, 90c



24-Pt. Holly Border No. 2, One Color, 36-inch font, \$2.00. Two Colors, 36-inch font, 18 inches in each color, \$2.00

36-Pt. Holly Border No. 3, One Color, 36-inch font, \$2.50. Two Colors, 36-inch font, 18 inches in each color, \$2.50
72-Pt. Holly Wreath, One Color, 40c; Two Colors, 80c

36-Pt. Holly Border No. 1, One Color, 24-inch font, \$1.65. Two Colors, 24-inch font, 12 inches in each color, \$1.65

THE H. C. HANSEN TYPE FOUNDRY



Cast from Superior Copper Alloy Metal

**BUFFALO BORDER
No. 3**

12-POINT 54 INCHES \$1.50

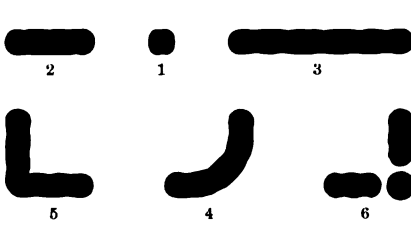

**BUFFALO OUTLINE BORDER
No. 3**

12-POINT 54 INCHES \$1.50

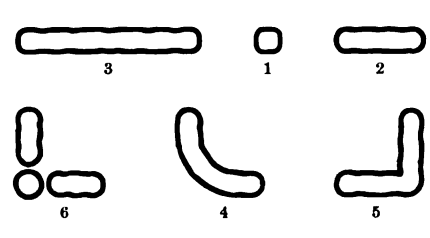

**BUFFALO BORDER
No. 5**

6-POINT 60 INCHES \$1.50

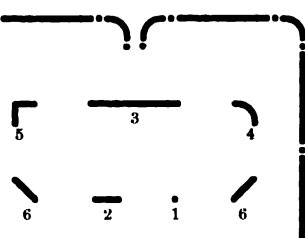

**The H. C. Hansen
Type Foundry**

**BUFFALO OUTLINE BORDER
No. 4**

6-POINT 60 INCHES \$1.50

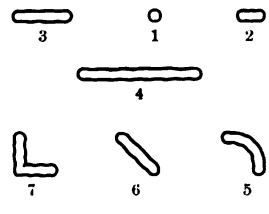

**BUFFALO BORDER
No. 4**

6-POINT 60 INCHES \$1.50

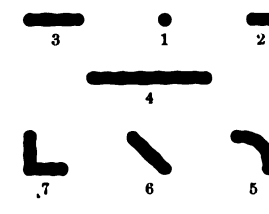

THE H. C. HANSEN TYPE FOUNDRY

The Runion Investment Co.

Composed of Real Live Printers who have made a small investment in Runion Border Preferred and are now reaping big profits



MULLER ORNAMENT NO. 1
30 CENTS PER SET
OF TWO

For further particulars address
**The H. C. Hansen
Type Foundry**

Cast from Superior Copper Alloy Metal

12-POINT RUNION BORDER 54 INCHES \$1.50

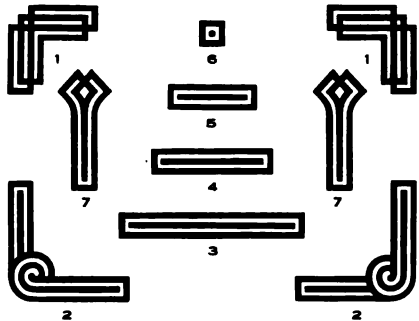

The Runion Border



Shown on this page is one which we are pleased to present as having a great range of usefulness, being equally adaptable to the needs of newspaper, magazine and job printers. The Type shown is the

Cambridge Series

Revised Price List April, 1907

Connoisseur Brand Grocers and Bakers Specialties



PRINTERS' JOY NO. 14
30 CENTS

Cambridge Manufacturing Co.
Cambridge, Massachusetts

























STUDIO ORNAMENTS

Cast from Superior Copper Alloy Metal

\$6.00 per font \$3.25 per half font

CHARACTERS

					
168	169	170	171	172	173
					
174	175	176	177		
					
178	179	180	181		
					
182	183	184	185	186	
					
187	188	189			

Full font contains 18 characters No. 168, 36 each Nos. 169 to 172, 12 No. 173, 8 No. 174, 6 No. 175, 8 each Nos. 176 to 181, and 6 each Nos. 182 to 189



No. 168 6-Pt. 60 inch font \$1.50

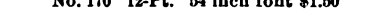

No. 169 12-Pt. 54 inch font \$1.50

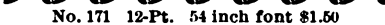

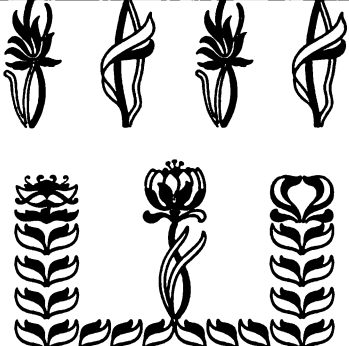
No. 170 12-Pt. 54 inch font \$1.50



No. 171 12-Pt. 54 inch font \$1.50



No. 172 12-Pt. 54 inch font \$1.50

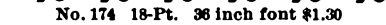

No. 173 12-Pt. 54 inch font \$1.50

No. 174 18-Pt. 36 inch font \$1.30

No. 176 24-Pt. 36 inch font \$1.05

No. 178 24-Pt. 36 inch font \$1.65

THE H. C. HANSEN TYPE FOUNDRY



The Aladdin Ornaments

Font, containing one each Nos. 1, 3, 5, 7, 8, 11 and 15, and two each Nos. 2, 4, 6, 9, 10 and 12, \$4.00



No. 1 72-Pt. 35 cts

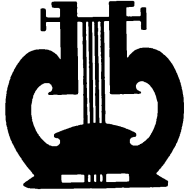

No. 3 72-Pt. 40 cts



No. 5 72-Pt. 35 cts

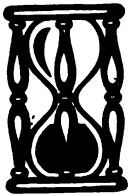

No. 7 72-Pt. 35 cts



No. 8 72-Pt. 35 cts



No. 9 72-Pt. 25 cts



No. 10 48-Pt. 20 cts



No. 11 48-Pt. 35 cts



No. 6 48-Pt. 20 cts



No. 2 48-Pt. 20 cts



No. 15 60-Pt. 35 cts



No. 12 24-Pt. 15 cts

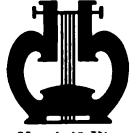

No. 4 48-Pt. 20 cts

All Type and Ornaments cast from Superior Copper Alloy Metal

Bird Ornaments

Per set of one each, \$1.00



No. 3 48-Pt. 35 cts



No. 2 72-Pt. 35 cts



No. 4 48-Pt. 35 cts



No. 1 24-Pt. 35 cts



ALADDIN

AND HIS WONDERFUL LAMP



COULD NEVER HAVE BEEN IN IT COMPARED WITH THE RESULTS WHICH MAY BE OBTAINED BY THE ALADDIN ORNAMENTS



Made only by

THE H. C. HANSEN TYPE FOUNDRY



Aladdin Ornament No. 12 18 inch font \$1.50

Lights of Other Days



A TRUE STORY CONCERNING THE ALADDIN ORNAMENTS

Made by

The H. C. Hansen Type Foundry

THE H. C. HANSEN TYPE FOUNDRY



NEW FLORAL ORNAMENTS



No. 701 One color 40c
Two colors 80c

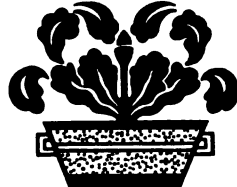

No. 702 40c

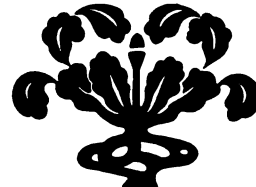

No. 705 40c



No. 25 30c



No. 709 35c



No. 704 25c



No. 26 30c



No. 703 15c

GRAPEVINE
BORDERS

36-Pt. Grapevine Border

30 inches \$2.50

AND

New Ornaments

Cast from Superior Copper Alloy Metal



36-Pt. Florette Orn. No. 4, 25c
Font of 18 characters, \$1.50



36-Pt. Florette Orn. No. 4, 25c
Font of 18 characters, \$1.50

72-POINT FLORETTE ORNAMENTS

Assorted font containing 4 characters each of Nos. 1, 5, 6, 7, 8, 9, and 2 each of Nos. 2, 3, 4, 10, \$2.50. Single character, 25c
Font of 36 characters of either of Nos. 1, 5, 6, 7, 8, 9, 10, \$2.00. 24 characters of No. 2, \$2.00. 18 characters of No. 3, \$2.00



No. 1



No. 2



No. 3



No. 5



No. 6



No. 7



No. 8



No. 9



No. 10

36-POINT TAILPIECE ORNAMENTS



No. 11



25 cts. per pair



No. 12



24-Pt. Grapevine Border, 36 inches \$2.00

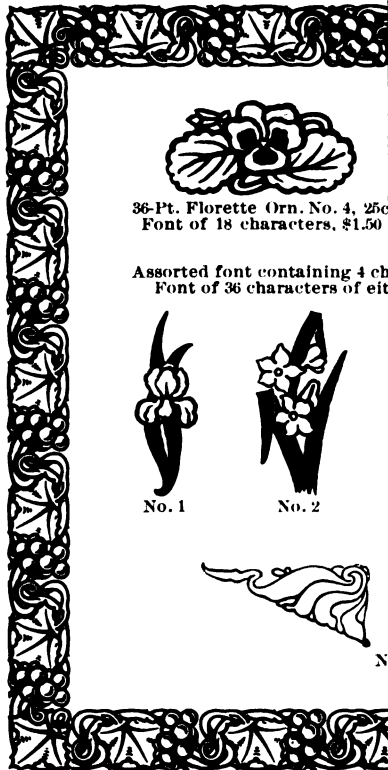

THE H. C. HANSEN TYPE FOUNDRY



PRINTERS' JOYS

ALWAYS PLEASSED TO
SERVE YOU



COOK, the BAKER
Corner High & Elm Sts.



No. 12 15c



No. 13 30c



No. 1
One color, 40c
Two colors, 80c



No. 6 One color, 35c
Two colors, 70c



No. 18 30c



No. 17 15c

Our Hobby



BEST GOODS AT
LOWEST PRICES

We hope to have and
to hold your trade with
courtesy also a feature

BROWN & WHITE
Dry Goods Dealers CITY SQ.

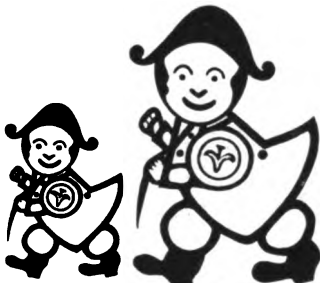

No. 4 25c

No. 3 40c



No. 5 10c



No. 11 10c



Ring us up
CALL 2738 MAIN
THE H. C. HANSEN
TYPE FOUNDRY

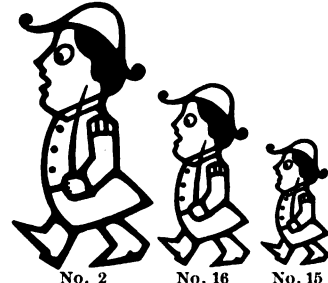

No. 2
One color, 40c
Two colors, 80c

No. 16
25c

No. 15
15c



No. 22 25c



No. 7 20c



No. 9 10c



No. 10 10c



No. 8 20c



No. 19 30c



No. 20 One color, 45c
Two colors, 90c



No. 23 40c

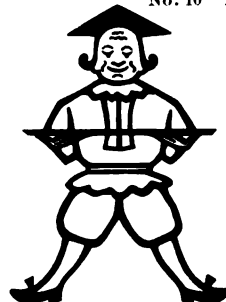

No. 21 45c



No. 14 30c

THE H. C. HANSEN TYPE FOUNDRY



PANEL BORDERS

**PANEL BORDER
No. 1**

3-Point on 6-Point
60 inches \$1.50

12-POINT PANEL BORDER, NO. 1

54 inches \$1.50

**PANEL BORDER
No. 3**

6-Point
60 inches \$1.50

PALISADE ORNAMENTS

No. 1

No. 2

Per set of six each, \$1.00

MULLER ORNAMENTS

No. 1. 48-Point. 30c per pair

No. 2. 72-Point. 40c per pair

AUTOMOBILES

No. 708. 48-Point, 35c

No. 707. 72-Point, 60c

BOSTON BEAN POTS

No. 1

No. 2

No. 3

No. 4

No. 5

No. 6

12-Point. One color, 48-inch font \$1.50
 Two colors, 48-inch font (24 inches each color) 1.50
 24-Point. One color, 36-inch font 2.00
 Two colors, 36-inch font (18 inches each color) 2.00
 48-Point. One color, 18-inch font 2.00
 Two colors, 18-inch font (9 inches each color) 2.00
 Single characters: 48-Point, 15c; 24-Point, 10c

THE H. C. HANSEN TYPE FOUNDRY



IMPERIAL BORDERS AND BANDS

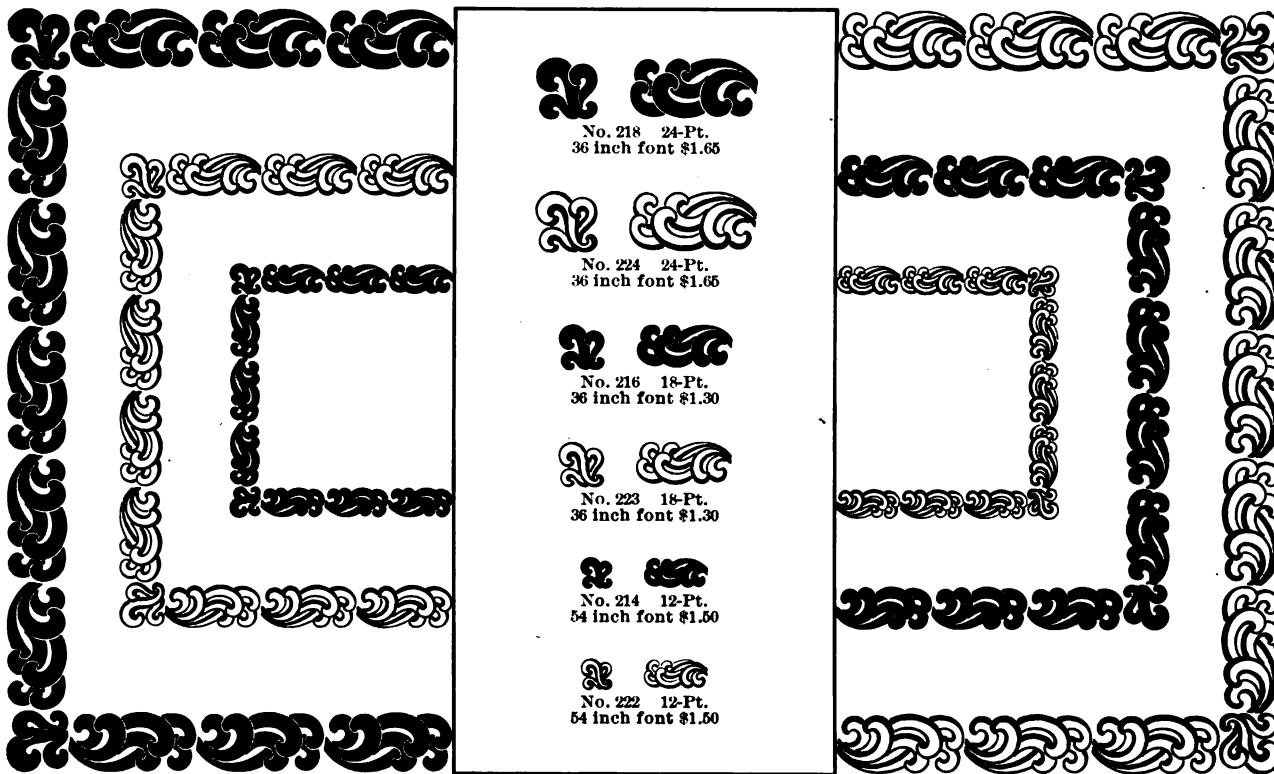

No. 218 24-Pt.
36 inch font \$1.65

No. 224 24-Pt.
36 inch font \$1.65

No. 216 18-Pt.
36 inch font \$1.30

No. 223 18-Pt.
36 inch font \$1.30

No. 214 12-Pt.
54 inch font \$1.50

No. 222 12-Pt.
54 inch font \$1.50



No. 219 24-Pt.
36 inch font \$1.65

No. 217 18-Pt.
36 inch font \$1.30

No. 215 12-Pt.
54 inch font \$1.50

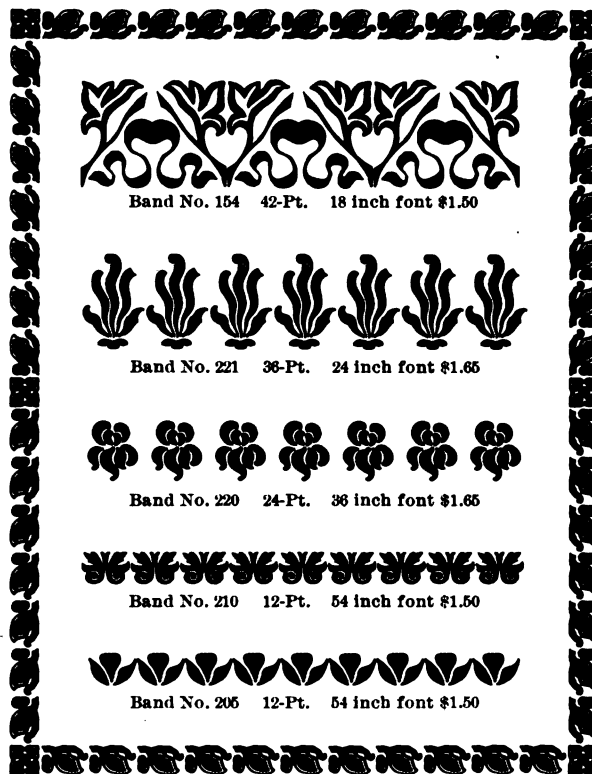

Band No. 154 42-Pt. 18 inch font \$1.50

Band No. 221 36-Pt. 24 inch font \$1.65

Band No. 220 24-Pt. 36 inch font \$1.65

Band No. 210 12-Pt. 54 inch font \$1.50

Band No. 205 12-Pt. 54 inch font \$1.50

THE H. C. HANSEN TYPE FOUNDRY

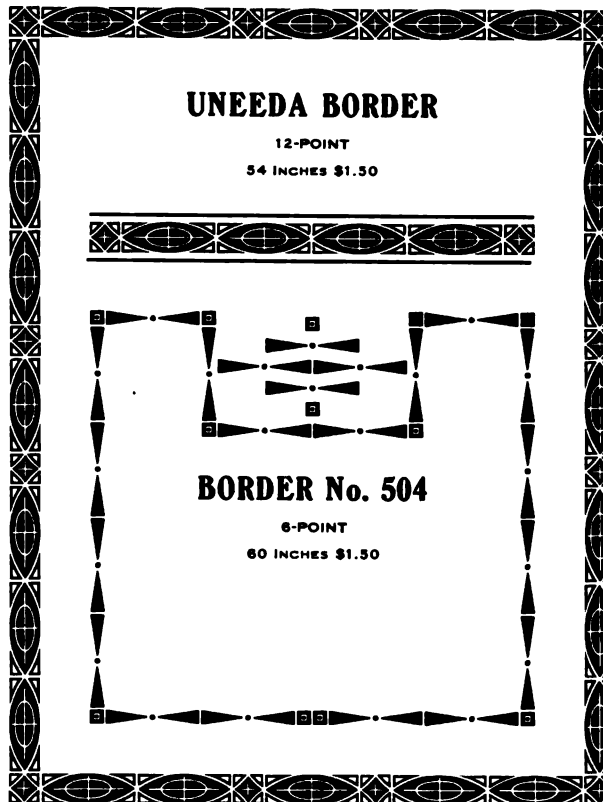
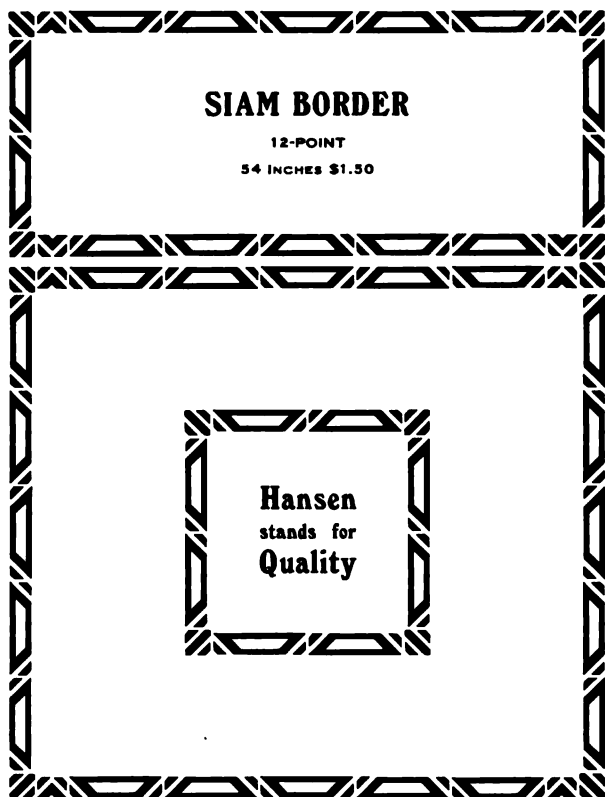
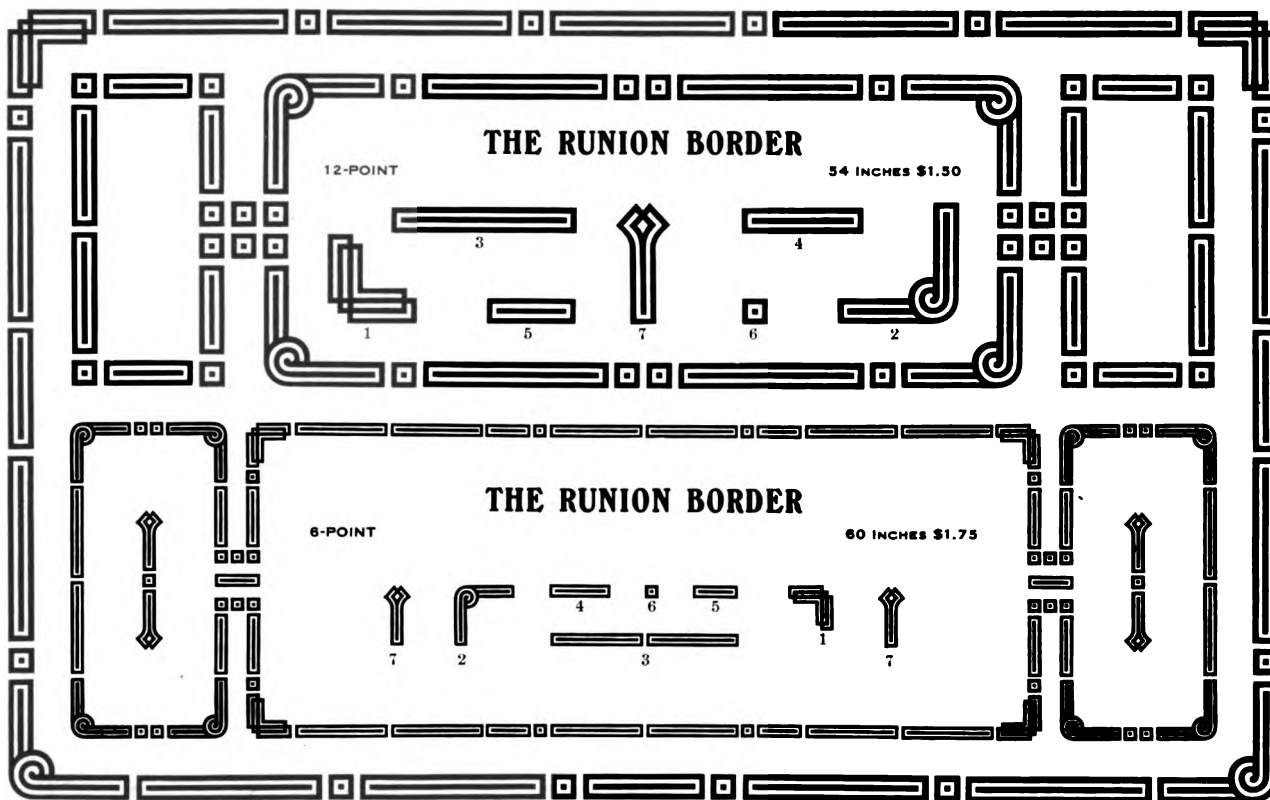

THE H. C. HANSEN TYPE FOUNDRY

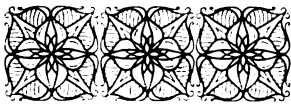

No. 1 36-Pt. 10c each
24-inch font \$2.00



No. 3 72-Pt.
20c each



No. 4 72-Pt.
20c each



No. 5 12-Pt. 48-inch font \$2.00



No. 6 12-Pt. 48-inch font \$2.00



No. 2 36-Pt. 10c each
24-inch font \$2.00

HANSEN'S ARTISTIC AND UP-TO-DATE LACE ORNAMENTS

FOR PROPER EMBELLISHMENT
OF MODERN TYPOGRAPHY

Assorted font containing eight each Nos. 1 and 2, six each Nos. 3
and 4 and ten each Nos. 5 and 6 \$2.50

The Arancio Border

18-Point. 36 inches \$1.75

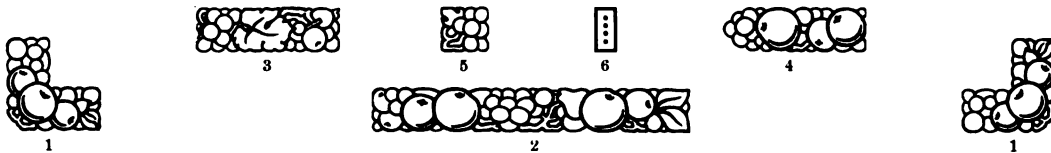

12-Point. 48 inches \$2.00

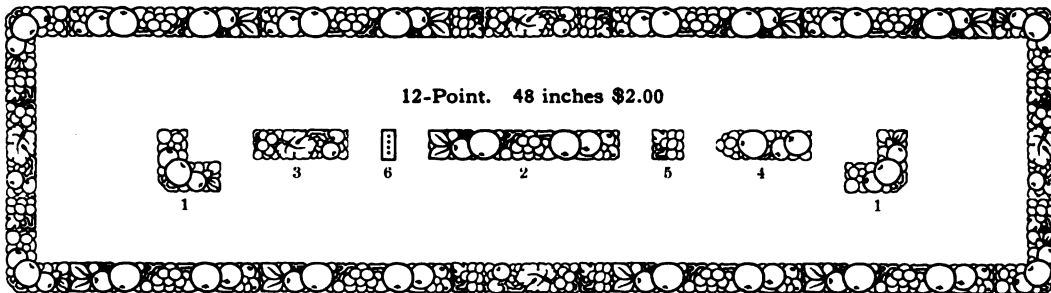

THE H. C. HANSEN TYPE FOUNDRY



THE UNIVERSITY BORDER

30-Point

24 inches \$1.35

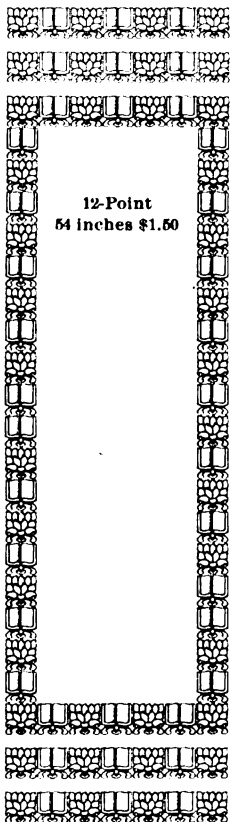
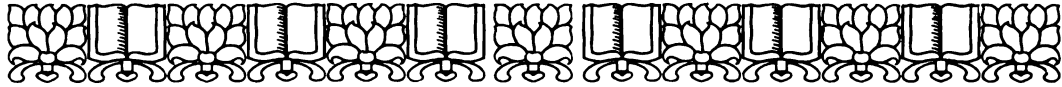

12-Point
54 inches \$1.50

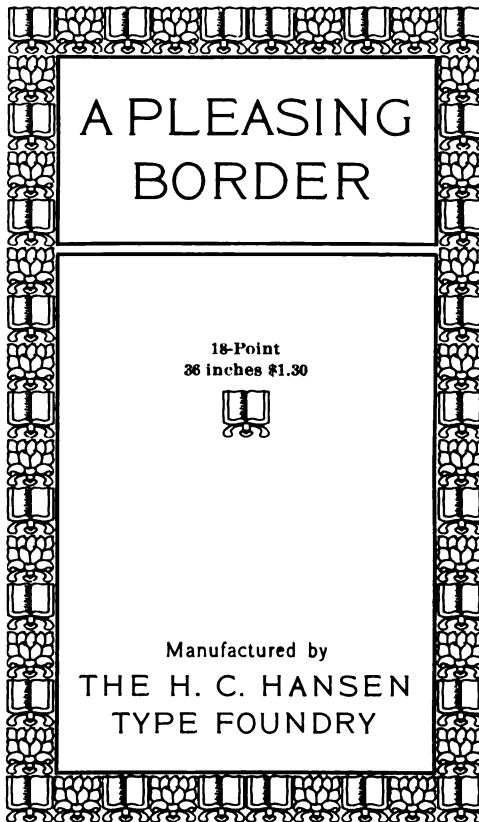

A PLEASING BORDER

18-Point
36 inches \$1.30



Manufactured by
THE H. C. HANSEN
TYPE FOUNDRY

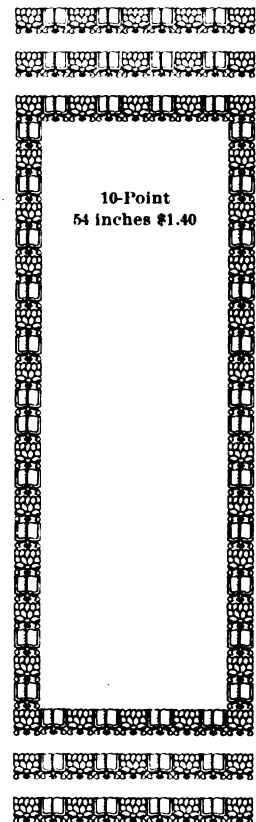

10-Point
54 inches \$1.40

24-Point

36 inches \$1.65

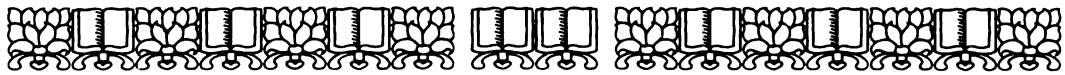

36-Point

24 inches \$1.65

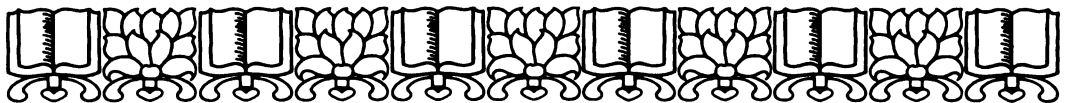

THE H. C. HANSEN TYPE FOUNDRY



Crystal Border
Black and Outline

18-Pt. No. 193. 36 inches, \$1.30

12-Pt. No. 192
54 inches, \$1.50

6-Pt. No. 191
60 inches, \$1.50

6-Pt. No. 196
60 inches, \$1.50

12-Pt. No. 195
54 inches, \$1.50

18-Pt. No. 194. 36 inches, \$1.30

Egg-and-Bart Border
54 inches, \$2.00

A Handsome Border of Classic Design

RIMMED SWASTIKA

24-Point
36 inches, \$1.65

18-Point
36 inches, \$1.30

12-Point
54 inches, \$1.50

SQUARE UNIT BORDERS

6-Pt. No. 500. 60 inches, \$1.50

8-Pt. No. 59. 54 inches, \$1.35

The Square Unit Borders are very appropriate for the style of ornamentation much in vogue at present

10-Pt. No. 71. 54 inches, \$1.40

12-Pt. No. 81. 54 inches, \$1.50

THE H. C. HANSEN TYPE FOUNDRY



HANSEN OLD STYLE INITIALS

Electrotyped on Metal Base

48-POINT BODY

ANY LETTER EXCEPT X

PRICE, EACH \$0.40



FERNCROFT INITIALS NO. 1

Cast in Type Mould



One font, or set of one each from A to Z, with ornaments, \$7.50. Single initial, 30 cents each. Ornaments are designed to be used with initial above, below or on left side.

FERNCROFT INITIALS NO. 2

Cast in Type Mould



One font, or set of one each from A to Z, with ornaments, \$9.50 Single initial 40 cents

THE H. C. HANSEN TYPE FOUNDRY



The Alfred Initials Numbers 1 and 2

MADE BY THE H. C. HANSEN TYPE FOUNDRY

ALFRED INITIALS No. 1



Cast in Type Mould from Superior Copper Alloy Type Metal
 72-Point. One font A to Z, \$8.00. Single Initial, 40 cents each. Choice of either style A or T
 Color for any initial, 30 cents each. Font, \$5.00

ALFRED INITIALS No. 2



Cast in Type Mould from Superior Copper Alloy Type Metal
 48-Point. One font A to Z, \$6.50. Single Initial, 30 cents each. Choice of either style A or T.
 Color for any initial, 20 cents each. Font, \$3.50.

INITIAL LETTERS WILL GIVE INDIVIDUALITY AND DISTINCTION TO A PIECE OF PRINTING NOT TO BE OBTAINED OTHERWISE. *The* ALFRED INITIALS SHOWN ABOVE POSSESS THESE CHARACTERISTICS. THEY ARE VERY EFFECTIVE AND WILL MAKE A VALUABLE ADDITION TO PRINTING OFFICES

H. C. HANSEN TYPE FOUNDRY
 190-192 CONGRESS STREET, BOSTON, MASS.
 New York Branch, 43 Centre Street

The SOMERSET CLUB of BOSTON

NOTICE IS HEREBY GIVEN THAT IN ACCORDANCE WITH A RECENT VOTE OF THE COUNCIL OUTSIDE GUESTS CANNOT BE INVITED TO ATTEND THE NEXT MEETING OF THE CLUB ON MONDAY, JULY THE SIXTEENTH. ON THIS OCCASION MEMBERS ONLY WILL BE GIVEN ADMISSION TO THE CLUB HOUSE

E. A. HURTIG, Secretary U. C. IDE, President



The Sylph Initials

Cast from Superior Copper Alloy Metal

60-Point Single letter 30c 3A \$7.00

A B C D

48-Point Single letter 25c 4A \$5.00

E H G H I

36-Point 5A \$4.00

J K L M N O

30-Point 5A \$3.50

P Q R S T U V L
W X Y Z &

24-Point 6A \$2.50

A B C D E H G H I J K L
M N 1 2 3 4 5 6 7 8 9 0 O P

18-Point 6A \$1.75

A B C D E H G H I J K L M N O
P Q R S T U V W X Y Z

14-Point 7A \$1.50

A B C D E H G H I J K L M N O P Q
R S T U V W X Y Z

12-Point 8A \$1.25

A B C D E H G H I J K L M N O P Q R
S T U V W X Y Z

10-Point 8A \$1.00

A B C D E H G H I J K L M N O P Q R S T U V
W X Y Z

Sylph Initials

ARE based on the formation of the round Gothic Capitals used extensively by the scribes of the fifteenth century, but have been re-cut and otherwise improved, which has added to their original beauty. Cast in nine sizes from A to Z. The character & is made for each size but shown only in 30-Point



ALADDIN ORNAMENT NO. 2
48-PT. 20 CTS.



18-PT. STUDIO ORNAMENTS NO. 174. 36 INCHES \$1.30

Printers

who are looking for something artistic in Initial Letters will find these to be Perfect in Design and strictly up to date

Made by The H. C. Hansen Type Foundry

THE H. C. HANSEN TYPE FOUNDRY



H. C. HANSEN'S
BRASS RULES

OF SUPERIOR QUALITY
UNSURPASSED

■ PLAIN AND FANCY FACES ■
HALF TONE RULES, HIGH ART
RULES, LABOR-SAVING RULES
COLUMN RULES, HEAD RULES
ODD DESIGNS, CIRCLES, OVALS
DIAMONDS, DASHES, BRACES
BRASS CORNERS, ETC.

THE GREATEST VARIETY AND MOST
EXCLUSIVE DESIGNS EVER PRODUCED

THE H. C. HANSEN TYPE FOUNDRY
BOSTON NEW YORK



BRASS RULES

15-TO-PICA TO 3-PT. BODIES. TWO FOOT STRIPS

No.		PER FOOT	No.		PER FOOT	No.		PER FOOT
429	15 TO PICA.	8 cts.	112	2-PT.	10 cts.	127	5 TO PICA.	12 cts.
430	15 TO PICA.	10 cts.	113	POPULAR 2-PT. DOTTED	10 cts.	130	5 TO PICA.	12 cts.
431	15 TO PICA.	8 cts.	114	2-PT.	10 cts.	128	5 TO PICA.	12 cts.
432	1-PT.	5 cts.	514	2-PT.	10 cts.	129	5 TO PICA.	12 cts.
433	1-PT.	10 cts.	381	2-PT.	10 cts.	262	5 TO PICA.	15 cts.
428	1-PT.	5 cts.	468	2-PT.	10 cts.	267	5 TO PICA.	15 cts.
434	1-PT.	5 cts.	437	2-PT.	10 cts.	274	5 TO PICA.	15 cts.
101	10 TO PICA.	6 cts.	115	2-PT.	10 cts.	290	5 TO PICA.	15 cts.
435	10 TO PICA.	10 cts.	116	2-PT.	10 cts.	297	5 TO PICA.	15 cts.
102	10 TO PICA.	6 cts.	117	2-PT.	10 cts.	131	3-PT.	15 cts.
103	8 TO PICA.	7½ cts.	510	2-PT.	12 cts.	132	3-PT.	15 cts.
105	8 TO PICA.	7½ cts.	511	2-PT.	12 cts.	133	3-PT.	15 cts.
104	8 TO PICA.	7½ cts.	512	2-PT.	12 cts.	134	3-PT.	15 cts.
260	8 TO PICA.	12 cts.	118	2-PT.	12 cts.	135	3-PT.	15 cts.
283	8 TO PICA.	12 cts.	119	2-PT.	12 cts.	136	3-PT.	15 cts.
313	8 TO PICA.	12 cts.	120	2-PT.	12 cts.	137	3-PT.	15 cts.
382	8 TO PICA.	12 cts.	121	2-PT.	12 cts.	145	3-PT.	15 cts.
109	POPULAR 2-PT. HAIR LINE	10 cts.	122	2-PT.	12 cts.	249	3-PT.	15 cts.
343	2-PT.	10 cts.	123	2-PT.	12 cts.	427	3-PT.	15 cts.
436	2-PT.	10 cts.	124	2-PT.	10 cts.	426	3-PT.	15 cts.
513	2-PT.	10 cts.	125	2-PT.	12 cts.	138	3-PT.	15 cts.
126	2-PT.	10 cts.	261	2-PT.	12 cts.	139	3-PT.	15 cts.
248	2-PT.	10 cts.	266	2-PT.	12 cts.	441	3-PT.	15 cts.
508	POPULAR 2-PT. SIDE RULE	10 cts.	273	2-PT.	12 cts.	442	3-PT.	15 cts.
68	2-PT.	10 cts.	284	2-PT.	12 cts.	140	3-PT.	18 cts.
110	2-PT.	10 cts.	289	2-PT.	12 cts.	141	3-PT.	18 cts.
509	2-PT.	10 cts.	296	2-PT.	12 cts.	142	3-PT.	18 cts.
111	2-PT.	10 cts.	370	2-PT.	12 cts.			
			50	2-PT.	12 cts.			

For perfect results in mitering use Hansen's Mitering Machine

THE H. C. HANSEN TYPE FOUNDRY



BRASS RULES

3-PT. TO 4-PT. BODIES. TWO FOOT STRIPS

No.		PER FOOT	No.		PER	No.		PER FOOT
143	3-Pr.	18 cts.	409	3-Pr.	18 cts.	156	4-Pr.	24 cts.
144	3-Pr.	18 cts.	410	3-Pr.	18 cts.	157	4-Pr.	24 cts.
263	3-Pr.	18 cts.	421	3-Pr.	18 cts.	158	4-Pr.	24 cts.
268	3-Pr.	18 cts.	438	3-Pr.	18 cts.	159	4-Pr.	24 cts.
275	3-Pr.	18 cts.	146	4-Pr.	20 cts.	160	4-Pr.	24 cts.
280	3-Pr.	18 cts.	344	4-Pr.	20 cts.	161	4-Pr.	24 cts.
285	3-Pr.	18 cts.	67	4-Pr.	20 cts.	162	4-Pr.	24 cts.
291	3-Pr.	18 cts.	515	4-Pr.	20 cts.	163	4-Pr.	24 cts.
298	3-Pr.	18 cts.	166	4-Pr.	20 cts.	164	4-Pr.	24 cts.
303	3-Pr.	18 cts.	250	4-Pr.	20 cts.	165	4-Pr.	24 cts.
306	3-Pr.	18 cts.	439	4-Pr.	20 cts.	264	4-Pr.	24 cts.
310	3-Pr.	18 cts.	147	4-Pr.	20 cts.	269	4-Pr.	24 cts.
314	3-Pr.	18 cts.	521	4-Pr.	20 cts.	276	4-Pr.	24 cts.
337	3-Pr.	18 cts.	64	4-Pr.	20 cts.	286	4-Pr.	24 cts.
346	3-Pr.	15 cts.	148	4-Pr.	20 cts.	292	4-Pr.	24 cts.
371	3-Pr.	18 cts.	531	4-Pr.	20 cts.	299	4-Pr.	24 cts.
380	3-Pr.	15 cts.	149	4-Pr.	20 cts.	347	4-Pr.	20 cts.
388	3-Pr.	18 cts.	150	4-Pr.	20 cts.	352	4-Pr.	20 cts.
391	3-Pr.	18 cts.	151	4-Pr.	20 cts.	376	4-Pr.	24 cts.
51	3-Pr.	18 cts.	152	4-Pr.	20 cts.	516	4-Pr.	24 cts.
54	3-Pr.	18 cts.	526	4-Pr.	20 cts.	378	4-Pr.	24 cts.
393	3-Pr.	18 cts.	153	4-Pr.	20 cts.	379	4-Pr.	24 cts.
406	3-Pr.	18 cts.	154	4-Pr.	20 cts.	52	4-Pr.	24 cts.
407	3-Pr.	18 cts.	155	4-Pr.	24 cts.			
408	3-Pr.	18 cts.						

Can match accurately any single, parallel, double or triple rule shown in any specimen book at regular prices.

THE H. C. HANSEN TYPE FOUNDRY



BRASS RULES

4-PT. TO 6-PT. BODIES. TWO FOOT STRIPS

No.		PER FOOT	No.		PER FOOT	No.		PER FOOT
383	4-PT.	24 cts.	174	5-PT.	30 cts.	447	5-PT.	25 cts.
397	4-PT.	24 cts.	175	5-PT.	30 cts.	448	5-PT.	25 cts.
402	4-PT.	24 cts.	176	5-PT.	30 cts.	449	5-PT.	30 cts.
411	4-PT.	24 cts.	422	5-PT.	30 cts.	419	5-PT.	30 cts.
412	4-PT.	24 cts.	177	5-PT.	30 cts.	420	5-PT.	30 cts.
413	4-PT.	24 cts.	178	5-PT.	25 cts.	182	6-PT.	30 cts.
414	4-PT.	24 cts.	55	5-PT.	30 cts.	345	6-PT.	30 cts.
415	4-PT.	24 cts.	56	5-PT.	30 cts.	200	6-PT.	30 cts.
416	4-PT.	24 cts.	179	5-PT.	25 cts.	252	6-PT.	30 cts.
417	4-PT.	24 cts.	70	5-PT.	25 cts.	253	6-PT.	30 cts.
418	4-PT.	24 cts.	180	5-PT.	25 cts.	254	6-PT.	30 cts.
423	4-PT.	24 cts.	67 B	5-PT.	25 cts.	255	6-PT.	30 cts.
440	4-PT.	24 cts.	53	5-PT.	30 cts.	256	6-PT.	30 cts.
66 B	4-PT.	20 cts.	317	5-PT.	30 cts.	257	6-PT.	30 cts.
167	5-PT.	25 cts.	324	5-PT.	30 cts.	183	6-PT.	30 cts.
450	5-PT.	25 cts.	361	5-PT.	25 cts.	522	6-PT.	30 cts.
251	5-PT.	25 cts.	389	5-PT.	30 cts.	517	6-PT.	30 cts.
168	5-PT.	25 cts.	392	5-PT.	30 cts.	68 B	6-PT.	30 cts.
169	5-PT.	25 cts.	403	5-PT.	30 cts.	452	6-PT.	30 cts.
170	5-PT.	25 cts.	443	5-PT.	25 cts.	451	6-PT.	30 cts.
171	5-PT.	25 cts.	444	5-PT.	25 cts.	184	6-PT.	30 cts.
172	5-PT.	25 cts.	445	5-PT.	25 cts.	185	6-PT.	30 cts.
173	5-PT.	30 cts.	446	5-PT.	25 cts.			

Hansen Patented Machinery used in this Type Foundry

THE H. C. HANSEN TYPE FOUNDRY



BRASS RULES

6-PT. TO 7-PT. BODIES. TWO FOOT STRIPS

No.	6-PT.	PER FOOT	No.	6-PT.	PER FOOT	No.	6-PT.	PER FOOT
532		30 cts.	281		36 cts.	373		36 cts.
186		30 cts.	287		36 cts.	374		36 cts.
187		30 cts.	293		36 cts.	377		36 cts.
527		30 cts.	295		36 cts.	390		36 cts.
188		30 cts.	300		36 cts.	394		36 cts.
189		30 cts.	304		36 cts.	398		36 cts.
190		30 cts.	307		36 cts.	400		36 cts.
191		30 cts.	311		36 cts.	404		36 cts.
66		30 cts.	315		36 cts.	424		36 cts.
192		30 cts.	323		36 cts.	425		36 cts.
65		30 cts.	326		36 cts.	58		36 cts.
196		36 cts.	327		36 cts.	59		36 cts.
195		36 cts.	328		36 cts.	57		36 cts.
193		36 cts.	338		36 cts.	453		35 cts.
194		36 cts.	340		36 cts.	464		35 cts.
197		36 cts.	348		30 cts.	69 B		35 cts.
198		36 cts.	353		30 cts.	60		42 cts.
199		36 cts.	356		30 cts.	454		35 cts.
265		36 cts.	61		36 cts.	455		35 cts.
270		36 cts.	366		36 cts.	456		35 cts.
272		36 cts.	367		36 cts.	457		35 cts.
277		36 cts.	372		36 cts.			

Do not mutilate book. Order by body and number

THE H. C. HANSEN TYPE FOUNDRY



BRASS RULES

7-PT. TO 10-PT. BODIES. TWO FOOT STRIPS

No.		PER FOOT	No.		PER FOOT	No.		PER FOOT
458	7-PT.	35 cts.	209	8-PT.	40 cts.	368	8-PT.	48 cts.
459	7-PT.	35 cts.	210	8-PT.	40 cts.	395	8-PT.	48 cts.
460	7-PT.	35 cts.	211	8-PT.	40 cts.	399	8-PT.	48 cts.
461	7-PT.	35 cts.	212	8-PT.	40 cts.	466	8-PT.	40 cts.
462	7-PT.	42 cts.	259	8-PT.	40 cts.	467	8-PT.	40 cts.
463	7-PT.	42 cts.	213	8-PT.	40 cts.	469	9-PT.	45 cts.
201	8-PT.	40 cts.	214	8-PT.	40 cts.	476	9-PT.	45 cts.
221	8-PT.	40 cts.	215	8-PT.	40 cts.	470	9-PT.	45 cts.
258	8-PT.	40 cts.	216	8-PT.	48 cts.	471	9-PT.	45 cts.
202	8-PT.	40 cts.	217	8-PT.	48 cts.	472	9-PT.	45 cts.
523	8-PT.	40 cts.	218	8-PT.	48 cts.	473	9-PT.	45 cts.
518	8-PT.	40 cts.	219	8-PT.	48 cts.	474	9-PT.	54 cts.
70 B	8-PT.	40 cts.	220	8-PT.	48 cts.	475	9-PT.	54 cts.
203	8-PT.	40 cts.	278	8-PT.	48 cts.	538	9-PT.	54 cts.
204	8-PT.	40 cts.	301	8-PT.	48 cts.	222	10-PT.	50 cts.
205	8-PT.	40 cts.	318	8-PT.	48 cts.	232	10-PT.	50 cts.
206	8-PT.	40 cts.	321	8-PT.	48 cts.	223	10-PT.	50 cts.
533	8-PT.	40 cts.	322	8-PT.	48 cts.	224	10-PT.	50 cts.
207	8-PT.	40 cts.	325	8-PT.	48 cts.	225	10-PT.	50 cts.
528	8-PT.	40 cts.	357	8-PT.	40 cts.	226	10-PT.	50 cts.
208	8-PT.	40 cts.	362	8-PT.	40 cts.			

Accuracy and durability of Hansen's rule are unsurpassed

THE H. C. HANSEN TYPE FOUNDRY



BRASS RULES

10-PT. TO 12-PT. BODIES. TWO FOOT STRIPS

No.		PER FOOT	No.		PER FOOT	No.		PER FOOT
534	10-Pr.	50 cts.	234	12-Pr.	60 cts.	486	12-Pr.	72 cts.
529	10-Pr.	50 cts.	235	12-Pr.	60 cts.	333	12-Pr.	72 cts.
227	10-Pr.	50 cts.	236	12-Pr.	60 cts.	339	12-Pr.	72 cts.
524	10-Pr.	50 cts.	237	12-Pr.	60 cts.	341	12-Pr.	72 cts.
519	10-Pr.	50 cts.	238	12-Pr.	60 cts.	349	12-Pr.	60 cts.
228	10-Pr.	50 cts.	487	12-Pr.	72 cts.	350	12-Pr.	60 cts.
229	10-Pr.	60 cts.	239	12-Pr.	72 cts.	354	12-Pr.	60 cts.
230	10-Pr.	60 cts.	271	12-Pr.	72 cts.	358	12-Pr.	60 cts.
231	10-Pr.	60 cts.	279	12-Pr.	72 cts.	364	12-Pr.	60 cts.
539	10-Pr.	60 cts.	282	12-Pr.	72 cts.	369	12-Pr.	60 cts.
363	10-Pr.	50 cts.	288	12-Pr.	72 cts.	384	12-Pr.	72 cts.
478	10-Pr.	50 cts.	294	12-Pr.	72 cts.	385	12-Pr.	72 cts.
479	10-Pr.	50 cts.	302	12-Pr.	72 cts.	386	12-Pr.	72 cts.
62	10-Pr.	60 cts.	305	12-Pr.	72 cts.	396	12-Pr.	72 cts.
233	12-Pr.	60 cts.	308	12-Pr.	72 cts.	401	12-Pr.	72 cts.
240	12-Pr.	60 cts.	312	12-Pr.	72 cts.	405	12-Pr.	72 cts.
483	12-Pr.	60 cts.	316	12-Pr.	72 cts.	525	12-Pr.	60 cts.
482	12-Pr.	60 cts.	319	12-Pr.	72 cts.	520	12-Pr.	60 cts.

Can match accurately any single, parallel, double or triple rule shown in any specimen book at regular prices.

THE H. C. HANSEN TYPE FOUNDRY



BRASS RULES

12-PT. TO 24-PT. BODIES. TWO FOOT STRIPS

No.		PER FOOT	No.		PER FOOT	No.		PER FOOT
535	12-PT.	60 cts.	497	18-PT.	90 cts.	360	18-PT.	90 cts.
530	12-PT.	60 cts.	244	18-PT.	90 cts.	365	18-PT.	90 cts.
540	12-PT.	72 cts.	498	18-PT.	90 cts.	375	18-PT.	\$1.08
63	12-PT.	72 cts.	496	18-PT.	90 cts.	499	18-PT.	\$1.08
329	12-PT.	72 cts.	309	18-PT.	\$1.08	387	18-PT.	\$1.08
330	12-PT.	72 cts.	320	18-PT.	\$1.08	501	24-PT.	\$1.20
331	12-PT.	72 cts.	334	18-PT.	\$1.08	502	24-PT.	\$1.20
332	12-PT.	72 cts.	335	18-PT.	\$1.08	503	24-PT.	\$1.20
493	15-PT.	90 cts.	336	18-PT.	\$1.08	504	24-PT.	\$1.44
536	15-PT.	75 cts.	342	18-PT.	\$1.08	505	24-PT.	\$1.20
537	15-PT.	75 cts.	351	18-PT.	90 cts.	506	24-PT.	\$1.20
241	18-PT.	90 cts.	355	18-PT.	90 cts.	507	24-PT.	\$1.20
245	18-PT.	90 cts.	494	18-PT.	\$1.08			
242	18-PT.	90 cts.	359	18-PT.	90 cts.			
243	18-PT.	90 cts.						

Every printing office should have a Hansen Complete Mitering Machine

THE H. C. HANSEN TYPE FOUNDRY



NEW BRASS RULES

No.	PER FOOT	No.	PER FOOT	No.	PER FOOT
*2 550	12 cts	2 611	15 cts	8 634	48 cts
3 551	18 cts	5 612	30 cts	10 635	60 cts
3 554	18 cts	6 613	36 cts	6 636	36 cts
4 552	24 cts	6 614	36 cts	12 637	72 cts
5 553	30 cts	10 615	60 cts	4 638	24 cts
5 555	30 cts	6 616	36 cts	4 639	24 cts
5 556	30 cts	3 617	18 cts	6 640	36 cts
6 557	36 cts	4 618	24 cts	6 641	36 cts
6 558	36 cts	6 619	36 cts	8 642	48 cts
6 559	36 cts	6 620	36 cts	8 643	48 cts
6 561	36 cts	8 621	48 cts	10 644	60 cts
7 560	42 cts	10 622	60 cts	10 645	60 cts
10 562	60 cts	12 623	72 cts	6 646	36 cts
12 563	72 cts	12 624	72 cts	6 647	36 cts
6 601	36 cts	6 625	36 cts	8 648	48 cts
6 602	36 cts	6 626	36 cts	8 649	48 cts
6 603	36 cts	10 627	60 cts	10 650	60 cts
6 604	36 cts	12 628	72 cts	10 651	60 cts
6 605	36 cts	3 629	18 cts	12 652	72 cts
6 606	36 cts	4 630	24 cts	12 653	72 cts
6 607	36 cts	6 631	36 cts	6 654	36 cts
6 608	36 cts	4 632	24 cts	12 655	72 cts
2 609	15 cts	6 633	36 cts		
3 610	18 cts				

*First figure indicates size of body

THE H. C. HANSEN TYPE FOUNDRY



New Brass Rules and Brass Corners

No.		PER FOOT	No.		PER FOOT	No.		PER FOOT
583	3-Pr.	15 cts.	589	3-Pr.	15 cts.	591	4-Pr.	20 cts.
584	4-Pr.	20 cts.	571	4-Pr.	20 cts.	592	5-Pr.	25 cts.
585	5-Pr.	25 cts.	572	5-Pr.	25 cts.	593	6-Pr.	30 cts.
586	6-Pr.	30 cts.	586	6-Pr.	30 cts.	594	8-Pr.	40 cts.
587	8-Pr.	40 cts.	573	8-Pr.	40 cts.	595	10-Pr.	50 cts.
588	10-Pr.	50 cts.	574	10-Pr.	50 cts.	596	12-Pr.	60 cts.
589	12-Pr.	60 cts.	575	12-Pr.	60 cts.	597	5-Pr.	25 cts.
590	18-Pr.	90 cts.	576	18-Pr.	90 cts.	598	6-Pr.	30 cts.
509	2-Pr.	10 cts.				599	8-Pr.	40 cts.
541	3-Pr.	15 cts.				600	10-Pr.	50 cts.
542	4-Pr.	20 cts.				549	12-Pr.	60 cts.
543	5-Pr.	25 cts.				577	5-Pr.	25 cts.
544	6-Pr.	30 cts.				578	6-Pr.	30 cts.
545	8-Pr.	40 cts.				579	8-Pr.	40 cts.
546	10-Pr.	50 cts.				580	10-Pr.	50 cts.
547	12-Pr.	60 cts.				581	12-Pr.	60 cts.
548	18-Pr.	90 cts.				582	18-Pr.	90 cts.

Square Brass Corners

Made from the best quality solid brass. Made to be used as corner pieces with rules Nos. 617 to 629 shown on page 225. Prices are for set of four

No. 100 No. 200

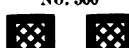
 15-Pt. \$0.40 15-Pt. \$0.40

No. 300

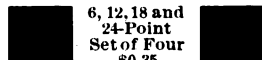
 18-Pt. \$0.50

Plain Black Corners

6, 12, 18 and 24-Point Set of Four \$0.35





ART BRASS RULES

Sold in Two-Foot Strips

ORIGINATED BY H. C. HANSEN

Prices are per foot

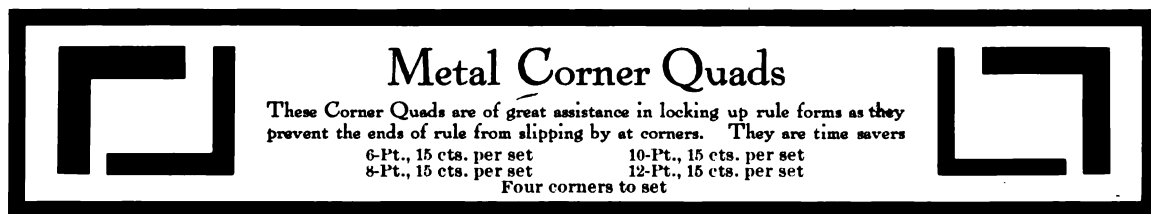
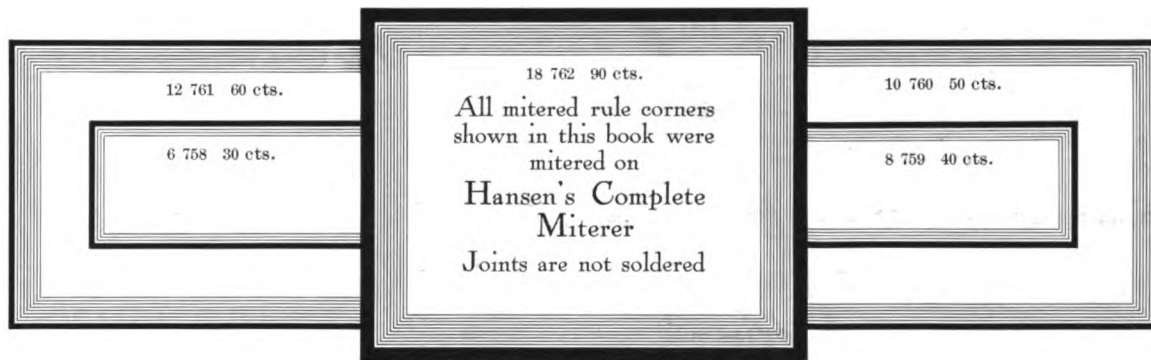
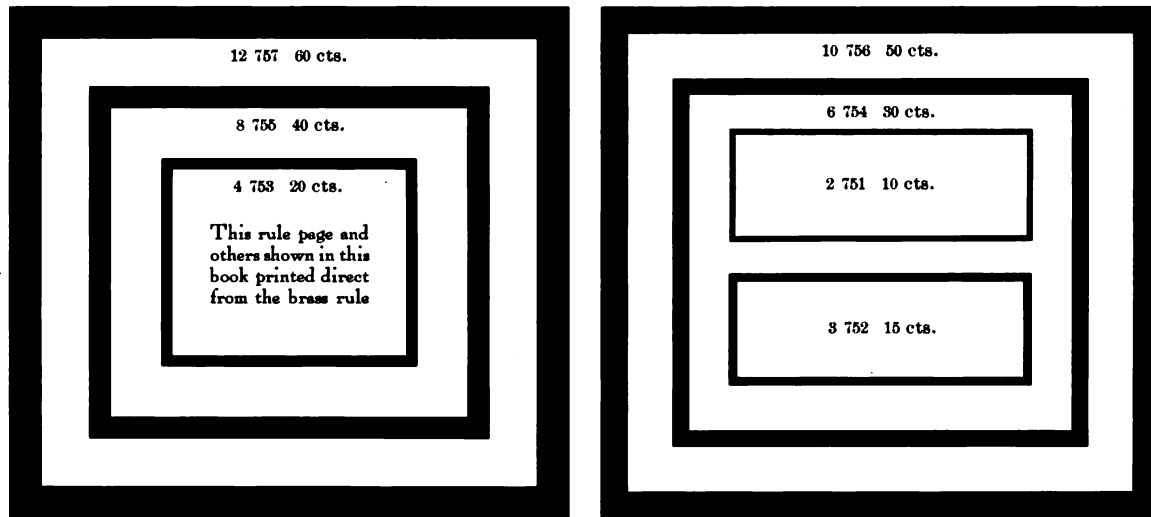
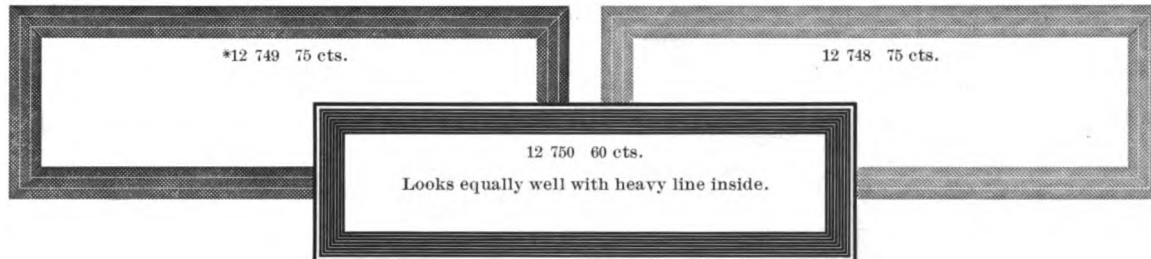

*First figure indicates size of body

THE H. C. HANSEN TYPE FOUNDRY



HALF TONE BRASS RULES

INVENTED BY H. C. HANSEN
Sold in two-foot strips

Wear better than half tone plates

Half Tone Rules No.	PER FOOT	No.	PER FOOT
*2 654	15 cts.	8 674	50 cts.
3 655	20 cts.	10 675	65 cts.
4 656	25 cts.	6 676	40 cts.
6 657	40 cts.	12 677	75 cts.
8 658	50 cts.	10 678	65 cts.
10 659	65 cts.	12 679	75 cts.
12 660	75 cts.	2 680	15 cts.
18 661	\$1.10	3 681	20 cts.
24 662	\$1.50	4 682	25 cts.
8 663	50 cts.	6 683	40 cts.
12 664	75 cts.	8 684	50 cts.
18 665	\$1.10	12 685	75 cts.
2 666	15 cts.	3 686	20 cts.
3 667	20 cts.	4 687	25 cts.
4 668	25 cts.	5 688	35 cts.
6 669	40 cts.	6 689	40 cts.
8 670	50 cts.	8 690	50 cts.
10 671	65 cts.	4 691	25 cts.
12 672	75 cts.	4 692	25 cts.
18 673	\$1.10	6 693	40 cts.
		8 694	50 cts.
		6 695	40 cts.

*First figure indicates size of body

Outside Rule No. 6 605. Per foot, 40 cts.

THE H. C. HANSEN TYPE FOUNDRY



HIGH ART BRASS RULES

Sold in two-foot strips

No.	PER FOOT	No.	PER FOOT
#4 696	25 cts.	2 715	10 cts.
3 697	18 cts.	3 716	15 cts.
4 698	24 cts.	4 717	20 cts.
4 699	24 cts.	6 718	30 cts.
6 700	36 cts.	8 719	40 cts.
8 701	48 cts.	12 720	60 cts.
6 702	40 cts.	4 721	24 cts.
4 703	24 cts.	8 722	48 cts.
5 704	30 cts.	4 723	24 cts.
6 705	36 cts.	6 724	36 cts.
6 706	36 cts.	8 725	48 cts.
6 707	40 cts.	3 726	18 cts.
10 708	65 cts.	4 727	24 cts.
6 709	40 cts.	5 728	30 cts.
12 710	75 cts.	6 729	36 cts.
12 711	75 cts.	8 730	48 cts.
18 712	\$1.10	6 731	30 cts.
12 713	75 cts.	6 732	30 cts.
24 714	\$1.50	6 733	30 cts.
		10 734	50 cts.
		12 735	60 cts.

*First figure indicates size of body

THE H. C. HANSEN TYPE FOUNDRY



THE HIGH ART RULES

Will supply a long felt want among progressive printers. They are much more durable than metal borders on long runs, with the added advantage of rapid handling. For the framing of magazine and newspaper advertisements they will prove valuable, creating a strong individuality that will attract the eye and get the business. The half tone rules when used in conjunction with half tone engravings and light type faces prove very pleasing.

Labor Saving Rule Fonts

These rules can be had in labor-saving fonts in any quantity with or without the mitered corners.

No.	PER FOOT
6 736	40 cts.
10 737	65 cts.
12 738	75 cts.
24 739	\$1.50
8 740	50 cts.
12 741	75 cts.
8 742	50 cts.
10 743	75 cts.
6 744	36 cts.
10 745	65 cts.
10 746	65 cts.
12 747	75 cts.

SHREVE, CRUMP & LOWE COMPANY

Jewelers, Silversmiths

Announce the arrival of a new and superb line of the Borneo

Diamonds

They represent the work of the most expert diamond cutters in the world, and are, without a doubt, the finest stones ever imported into this country. We invite you to an early inspection

Special Item

Solitaire Rings, 1 carat stones mounted in solid gold Tiffany settings, absolutely perfect stone

\$250

Sixth and Dunde Streets
Baltimore

Designed and Manufactured by

THE H. C. HANSEN TYPE FOUNDRY

190-192 Congress Street, Boston

43 Centre Street, New York



LABOR-SAVING BRASS LEADERS

Furnished on Standard Line unless otherwise ordered

Made from solid brass on the lining system; also made on any body to line with any face. Put up in regular fonts or made to order

LABOR-SAVING FONTS

The following prices are for regular scheme fonts. In the 5-lb. fonts the longest piece is 15 ems and in the 10-lb. fonts 20 ems, cut by half ems pica up to 4 ems, and even ems above 4 ems.

Size	6-Pt.	8-Pt.	10-Pt.	12 Pt.
1-pound font.....	\$ 1 70.....	\$ 1 60.....	\$ 1 50.....	\$ 1 40
2-pound font.....	3 40.....	3 20.....	3 00.....	2 80
3-pound font.....	4 95.....	4 65.....	4 50.....	4 05
4-pound font.....	6 40.....	6 00.....	5 80.....	5 20
5-pound font.....	7 75.....	7 25.....	7 00.....	6 50
10-pound font.....	14 00.....	13 50.....	13 00.....	12 00
15-pound font.....	21 00.....	19 50.....	18 75.....	18 00
20-pound font.....	27 00.....	25 00.....	24 00.....	23 00
25-pound font.....	33 75.....	31 25.....	30 00.....	28 75
50-pound font.....	65 00.....	60 00.....	57 50.....	55 00
100-pound font.....	125 00.....	115 00.....	110 00.....	105 00

6-Point 113 468 514

8-Point

10-Point

12-Point

BRASS TRADE SIGNS

Order by number 50 cents each



BRASS DASHES

Cut to single column

Nos. 138 to 153 each, \$0 07½
Nos. 156 to 170 each, 10

No.	Sample
138
139
140
141
142
144
145
146
147
149
151
153
156
158
160
162
164
166
168
170

ADVERTISING RULES

Cut any length, from any single, double, parallel or triple rule shown in this book. The following list shows a few of the faces generally used, with price list.

Size	Ems	2-Pt.	3-Pt.	4-Pt.	5-Pt.	6-Pt.
Single column 12½ to 15.....		\$0 02½	\$0 04	\$0 05	\$0 06	\$0 07½
Single column 15½ to 18.....		03	04½	05½	07	08½
Double column 24½ to 27.....		04½	06½	08	10	12½
Double column 27½ to 30.....		05	07	09	11	13½
Triple column 36½ to 42.....		07	10	13	16	19
Triple column 42½ to 48.....		08	11	14	18	21

115	2-Point	152	4-Point
116	2-Point	526	4-Point
124	2-Point	171	5-Point
109	2-Point	172	5-Point
436	2-Point	186	6-Point
110	2-Point	527	6-Point
138	3-Point	188	6-Point
147	4-Point		
139	3-Point		

BRASS SCORING RULES

2-Point, per foot.....	\$0 10
3-Point, per foot.....	15
4-Point, per foot.....	20
6-Point, per foot.....	30

BRASS DASH RULES

Cut any length face from any single, double, parallel or triple rule shown in this book. See side column for samples.

PERFORATING RULES

No. A. 2-Pt. Brass.	Per foot, \$0 15
No. B. 2-Pt. Brass.	Per foot, 15
No. C. 2-Pt. Steel.	Per foot, 40
No. D. 2-Pt. Steel.	Per foot, 40

Steel Perforating Rule put up in fonts containing 4 feet cut to pica ems of various lengths. Price, per font, \$2.00

HANSEN'S SPECIAL 2-Pt. STEEL CUTTING RULE

2-Pt. Steel Cutting Rule for steel cutting dies. 2-foot strips. Per foot, \$0 20



BRASS HEAD RULES

439	4-Pt.	526	4-Pt.
147	4-Pt.	139	3-Pt.
183	6-Pt.	162	4-Pt.
149	4-Pt.	172	5-Pt.
171	5-Pt.	187	6-Pt.
186	6-Pt.	527	6-Pt.
185	6-Pt.		

The following prices are for any Single, Double, Parallel or Triple Rule shown in this book. Regular sizes using 13-em column and 6-point column rule.

Pica Ems	3-Point	4-Point	5-Point	5½-Point	6-Point	7-Point	8-Point
4-column 52½	\$0 12	\$0 16	\$0 20	\$0 22	\$0 24	\$0 28	\$0 31
5-column 67	16	21	26	28	31	36	41
6-column 80½	18	24	30	33	36	42	48
7-column 94	21	28	34	38	41	48	55
8-column 107½	23	31	38	43	46	54	61
9-column 121	27	36	45	50	54	63	71

BRASS COLUMN RULES

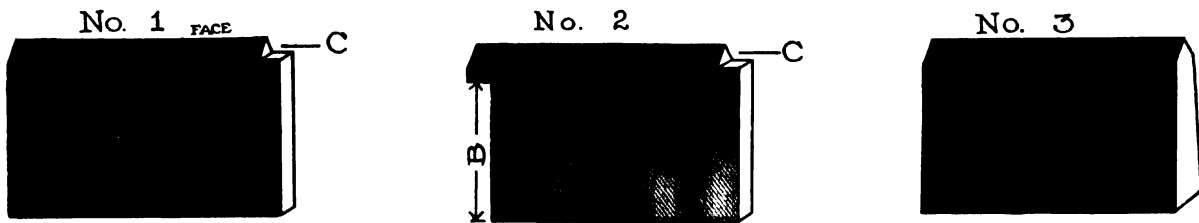

Style No. 1 shows regular notched column rule. When ordering give size of notch C in points, as well as length of face and body of rule. Six-point rule, unless otherwise ordered, is notched six points, eight-point is notched eight points, etc. Advertised prices are for full length over all.

Style No. 2 shows notch over and notch under. When ordering, give height of B, and also size of notch C in points.

Style No. 3 shows beveled column rule for linotype matter. When ordering this rule, the body is figured according to thickness at bottom. (5x6 figures as 6-point).

Style No. 4 shows column rule with notch under and shank. When ordering, give length of shank A and the height of notch B, also height and depth of notch D.

Style No. 5 shows column rule with shank. When ordering, give length of shank A and height of D.

BRASS COLUMN RULES

The following prices are for regular sizes using 13-em column. The usual style has a notch over (C No. 1) to allow for foot slug.

Size	In.	6-Pt.	7-Pt.	8-Pt.	9-Pt.	10-Pt.
4-column	13½	\$0 38	\$0 44	\$0 50	\$0 56	\$0 62
5-column	17½	48	56	63	71	78
6-column	19½	53	62	70	78	87
7-column	21½	58	68	77	86	95
8-column	23½	63	73	83	93	1 03
9-column	25½	69	79	90	1 01	1 12

Deduct 2 cents from above prices for column rules without notch C. Notch under for brass galleys, 5 cents extra (B No. 2). Lug for perfecting press, 10 cents extra (A No. 5). Lug and notch under for perfecting press, 15 cents extra (A and B No. 4).

Prices for all column rules are for length over all.

BEVELED LINOTYPE COLUMN RULES

With notch, as per Style No. 1

Size	Length	5x6-Pt.	6x7-Pt.	7x8-Pt.
6-column	19½ inches	\$0 74	\$0 86	\$0 98
7-column	21½ inches	81	95	1 07
8-column	23½ inches	88	1 02	1 16

Lug for perfecting press, 10 cents extra (A No. 5). Lug and notch under for perfecting press, 15 cents extra (A and B No. 4).

Prices for all column rules are for length over all.



THE H. C. HANSEN TYPE FOUNDRY

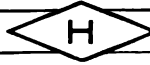

HANSEN'S SPECIAL MITERED LABOR-SAVING BRASS RULE

A NEW LABOR-SAVING FONT SCHEME

ORIGINATED BY THE H. C. HANSEN TYPE FOUNDRY

The best font system of rule ever designed for printers. An unequalled scheme for panel arrangements, labels and general commercial work, enabling speedy and practical arrangement with perfect corners. Better work and quicker.

No. 152. 4-PT.

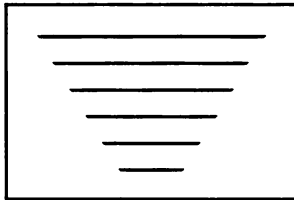
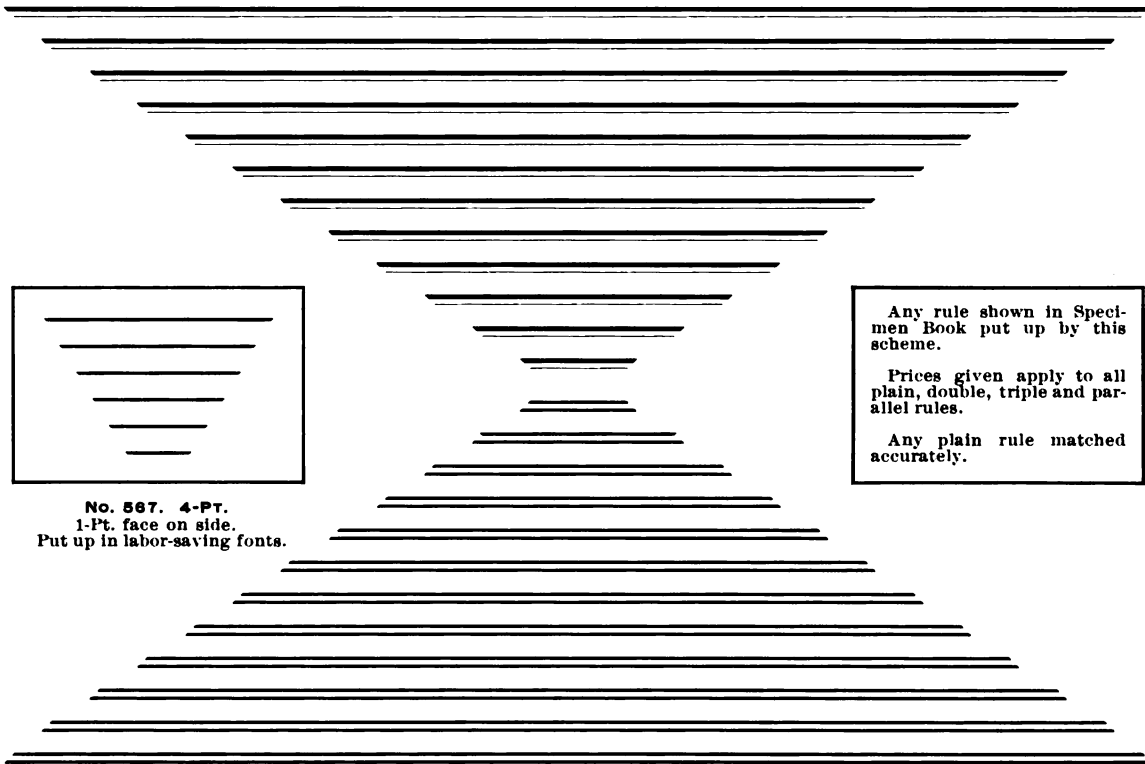

No. 567. 4-PT.
1-Pt. face on side.
Put up in labor-saving fonts.

Any rule shown in Specimen Book put up by this scheme.
Prices given apply to all plain, double, triple and parallel rules.
Any plain rule matched accurately.

No. 521. 4-PT.

SCHEMES AND PRICES

Full fonts contain 50 sets of rule, 4 pieces each length, from 1 to 50 ems inclusive, each piece being mitered on both ends and cut to 12-point, **inside measure** and numbered plainly.

2-Point Rule, per font	Price
3 " " " "	\$13.50
4 " " " "	12.50
5 " " " "	19.75
6 " " " "	23.50
8 " " " "	28.00
10 " " " "	36.00
12 " " " "	41.00
12 " " " "	48.00

Half fonts contain 25 sets of rule, 4 pieces each length, from 1 to 25 ems inclusive, each piece being mitered on both ends and cut to 12-point, **inside measure** and numbered plainly.

2-Point Rule, per font	Price
3 " " " "	\$ 5.00
4 " " " "	5.25
5 " " " "	7.50
6 " " " "	8.25
8 " " " "	10.25
10 " " " "	12.00
12 " " " "	13.50
12 " " " "	15.00

Prices subject to discount. **Outside measure** given if desired. Half size new rule case, specially designed to hold above rule, \$1.50
Further examples of attractive rule faces cut to special mitered labor-saving schemes shown on pages 234 and 235

THE H. C. HANSEN TYPE FOUNDRY



POPULAR BRASS RULES

MADE IN 2-FOOT STRIPS

PRICES ARE PER FOOT

*18 582 90c

12 581 60c

10 580 50c

8 579 40c

6 578 30c

5 577 25c

THESE RULES PUT UP IN
MITERED LABOR-SAVING FONTS
See Prices on Page 236

12 549 60c

8 599 40c

10 600 50c

5 597 25c

6 598 30c

Labor saving fonts, with or without
miters, put up in any quantity.

Hansen's Solid Brass Round Corners
furnished for any of these rules.

MITERED ON
HANSEN'S COMPLETE MITERER
THE BEST IN THE WORLD

3 569 15c

4 571 20c

6 566 30c

8 573 40c

10 574 50c

12 575 60c

18 576 90c

Use Hansen's Complete Lead and Rule Cutter *First Figure indicates size of body Use Hansen's Complete Miterer

THE H. C. HANSEN TYPE FOUNDRY



NEW DESIGNS IN BRASS RULES

MADE IN 2-FOOT STRIPS

PRICES ARE PER FOOT

10 546 50c

18 548 90c

12 547 60c

6 544 30c

8 545 40c

4 542 20c

5 543 25c

2 509 10c

3 541 15c

18 590 90c

12 589 60c

8 587 40c

10 588 50c

6 586 30c

5 585 25c

3 583 15c

4 584 20c

THESE RULES PUT UP IN LABOR-SAVING FONTS PRICES PAGE 238

DON'T BUY A LEAD AND RULE CUTTER UNTIL YOU HAVE BEEN HANSEN'S

8 594 40c

12 596 60c

10 595 50c

4 591 20c

6 593 30c

5 592 25c

Labor saving fonts, with or without miters, put up in any quantity.

Hansen's Solid Brass Round Corners furnished for any of the above rules.

NO OFFICE COMPLETE WITHOUT HANSEN'S COMPLETE MITERER AND HANSEN'S COMPLETE LEAD AND RULE CUTTER

THE H. C. HANSEN TYPE FOUNDRY



LABOR-SAVING BRASS RULES

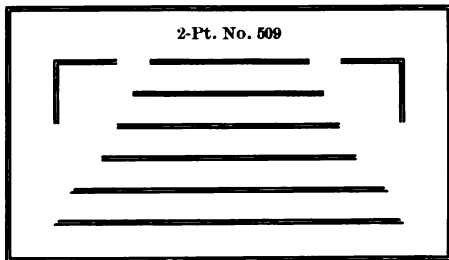

PLAIN

	1-LB.	3-LB.
1-Point . . .	\$2.10	\$5.70
1½ " . . .	1.95	5.40
2 " . . .	1.80	4.50
3 " . . .	1.55	4.35
4 " . . .	1.55	4.35
6 " . . .	1.50	4.20
8 " . . .	1.50	4.20
10 " . . .	1.50	4.05
12 " . . .	1.35	3.75

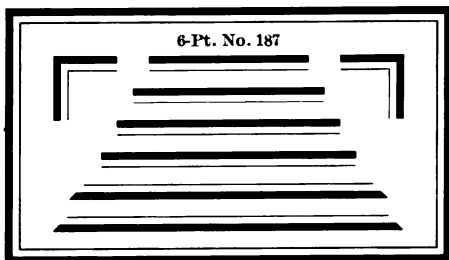
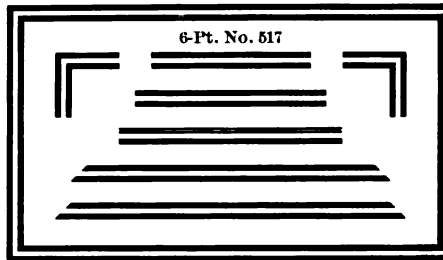

	5-LB.	10-LB.
1-Point . . .	\$8.75	\$17.00
1½ " . . .	8.25	15.00
2 " . . .	7.25	13.50
3 " . . .	6.75	12.50
4 " . . .	6.75	12.50
6 " . . .	6.50	12.50
8 " . . .	6.50	12.50
10 " . . .	6.50	12.00
12 " . . .	6.00	11.50

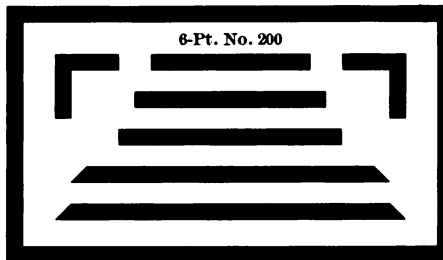

Mitered Corner Pieces are sold separately by set or font.

Sold also in Special Mitered Fonts and half fonts as per page 233.

Any other plain single, double or triple face rules at same prices.

All fonts put up to our regular Type Foundry brass rule schemes.

Change of these schemes at special prices.

FANCY

Fancy Rules put up in Labor-saving Fonts at the following prices:

	5-LB.	10-LB.
2-Point . . .	\$8.70	\$16.20
3 " . . .	8.10	15.00
4 " . . .	8.10	15.00
6 " . . .	7.80	15.00
8 " . . .	7.80	15.00
10 " . . .	7.80	14.40
12 " . . .	7.20	13.80

Mitered Corner Pieces are sold separately.

Fancy Rules are also put up in Special Mitered Fonts as per scheme on page 233 at the following prices:

	FONT	HALF FONT
2-Point . . .	\$16.20	\$ 6.00
3 " . . .	15.00	6.30
4 " . . .	23.70	9.00
6 " . . .	33.60	12.30
8 " . . .	43.00	14.40
10 " . . .	49.00	16.20
12 " . . .	57.60	18.00

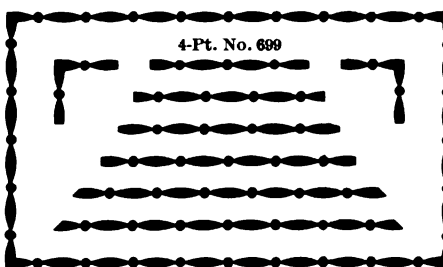
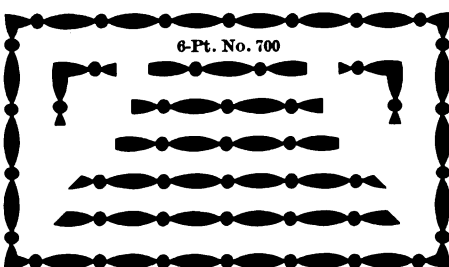
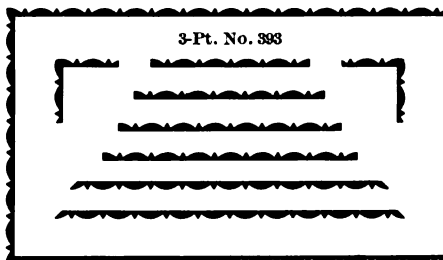
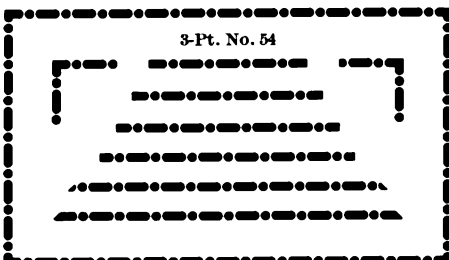

Other fancy faces at the above prices where pattern is such that they can be mitered to advantage

Insist on Hansen's Superior Quality

BRASS LEADS AND SLUGS

Our Brass Leads and Slugs are accurately made and are a necessity in newspaper and other offices where forms are subjected to heat as in stereotyping. Sold in 2-foot strips, cut to measure, and in labor-saving fonts as follows:

PRICE PER POUND

	STRIPS	TO MEASURE	LABOR-SAVING
1-Point . . .	\$0.85	\$1.25	\$1.75
1½ "90	1.15	1.60
2 "75	1.00	1.25
3 "75	1.00	1.25
4 "75	.95	1.20
6 "75	.95	1.20

HIGH ART BRASS RULE NO. 10 875



HANSEN'S STEEL CUTTING DIES

ORIGINATED BY H. C. HANSEN

The designs on this page represents the cutting edges of dies, made from the very finest quality of hardened steel enclosed in solid metal frames. See page 248.

These steel dies have been an important feature of the H. C. Hansen Type Foundry for years, and have given excellent satisfaction to hundreds of users.

They can be used on any ordinary platen press and enable the user to produce many unique novelties in "cut-outs" for booklets, etc. With a careful makeready, these dies will stand an unlimited number of impressions (a thin piece of brass glued to platen of press makes the best surface for the steel to strike on.) When dull, the face can be touched up with a fine file.

The designs shown on this page represent a few of the most common sizes and shapes. Prices will be quoted to interested parties on application. Give number of design wanted. When other shapes are desired, send sketch or drawing of same and we will quote prices.

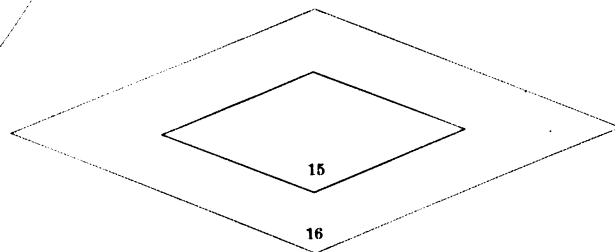
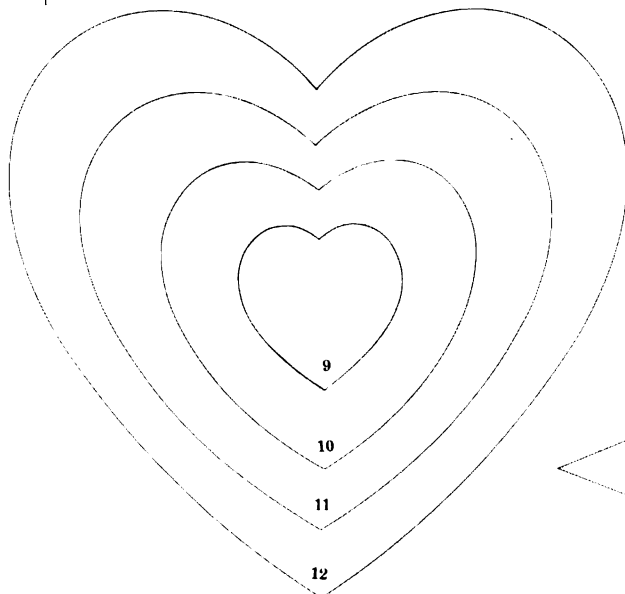
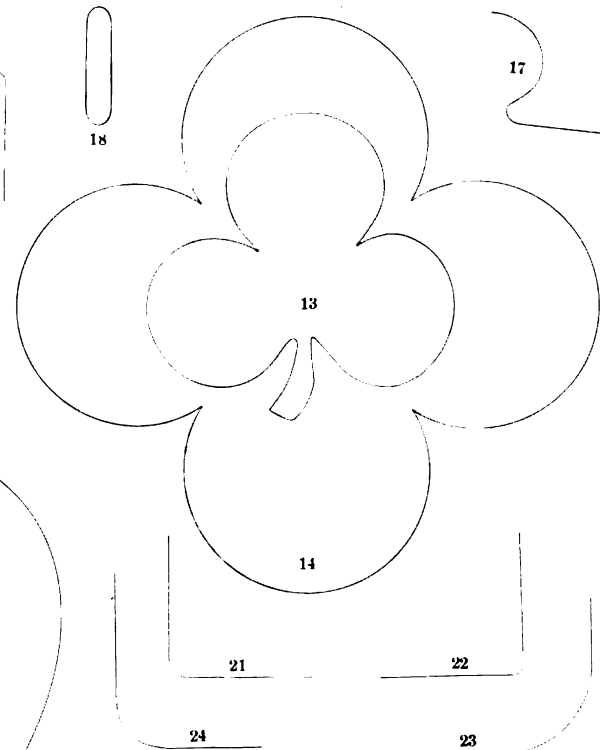
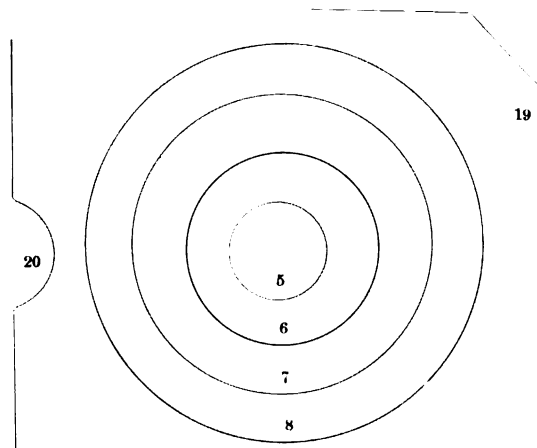
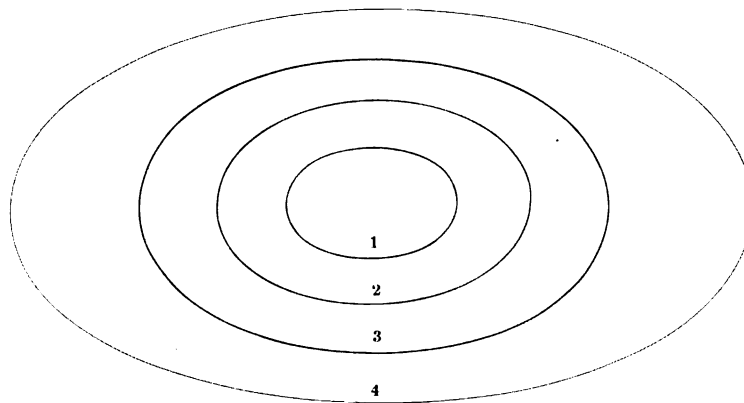

THE H. C. HANSEN TYPE FOUNDRY



HANSEN'S BRASS DASHES

4-Pt. Body. Cut to Single Column. 10c. each.

No. 1		No. 129		No. 47	
No. 2		No. 130		No. 48	
No. 3		No. 131		No. 49	
No. 4		No. 132		No. 50	
No. 5		No. 133		No. 51	
No. 6		No. 134		No. 52	
No. 7		No. 135		No. 53	
No. 8		No. 136		No. 54	
No. 9		No. 137		No. 55	
No. 10		No. 120		No. 56	
No. 11		No. 121		No. 57	
No. 12		No. 122		No. 58	
No. 13		No. 123		No. 59	
No. 14		No. 124		No. 60	
No. 15		No. 125		No. 61	
No. 16		No. 126		No. 62	
No. 17		No. 127		Nos. 63 to 68. 15 cents each	
No. 18		No. 38		No. 63	
No. 19		No. 39		No. 64	
No. 20		No. 40		No. 65	
No. 21		No. 41		No. 66	
No. 22		No. 42		No. 67	
No. 23		No. 43		No. 68	
No. 24		No. 44			
No. 25		No. 45			
No. 26		No. 46			
No. 27					
No. 28					
No. 29					
No. 30					
No. 31					
No. 32					
No. 33					
No. 34					
No. 35					
No. 36					
No. 37					

6-Pt. Body. Cut to Double Column Width. 25c. each

No. 69	
No. 70	
No. 71	
No. 72	
No. 73	
No. 74	
No. 75	

SPECIAL BRASS JOB DASHES, ON 2-POINT BODY. 5c. each.

No. 79	No. 80	No. 81	No. 82	No. 83
No. 84	No. 85	No. 86	No. 87	No. 88
No. 89	No. 90	No. 91	No. 92	No. 93
No. 94	No. 95	No. 96	No. 97	No. 98
No. 99	No. 100	No. 101	No. 102	No. 103
No. 104	No. 105	No. 106	No. 107	No. 108
	No. 109	No. 110	No. 111	
No. 112 10c.		No. 113 10c.		No. 114 10c.

THE H. C. HANSEN TYPE FOUNDRY



HANSEN'S BRASS BRACES

6-POINT BODY. MOST UNIFORM AND ACCURATE MADE

1 to 12—12 cents.

13 to 24—15 cents.

25 to 33—20 cents.

34 to 41—6 cents.

42 to 49—8 cents.

50 to 55—10 cents.

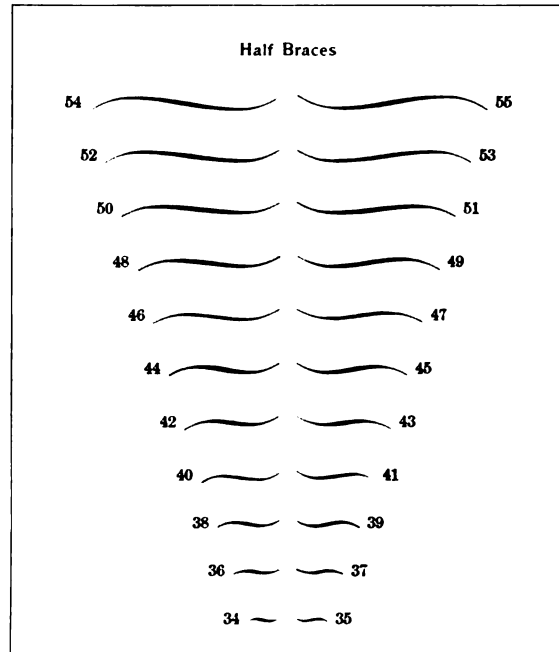
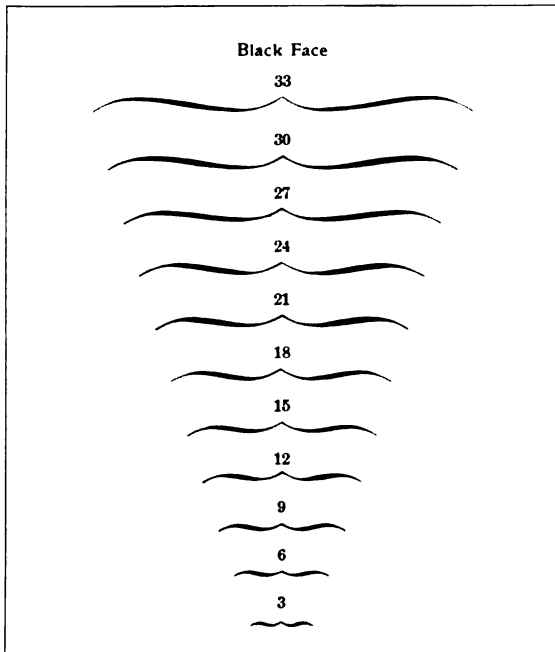
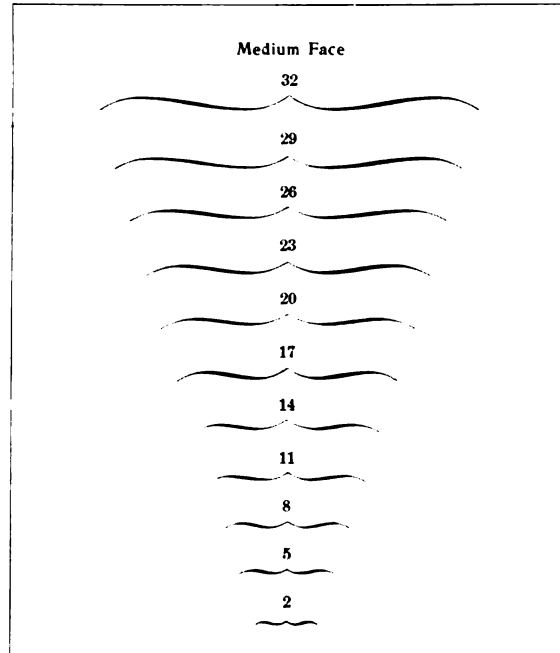
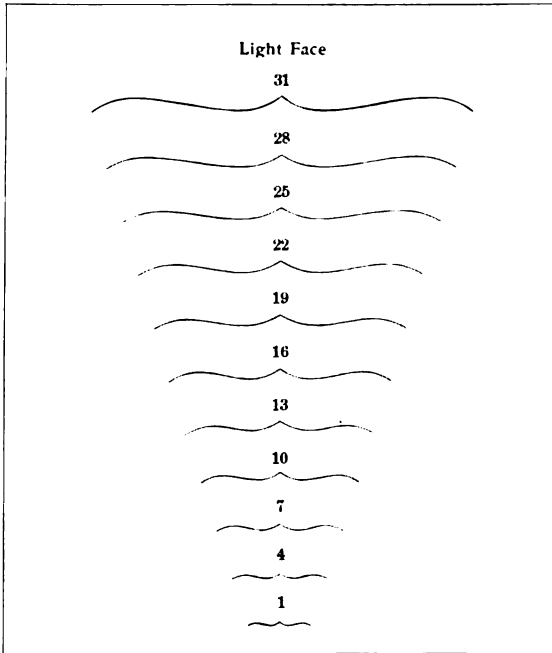

Longer and heavier braces made to order

THE H. C. HANSEN TYPE FOUNDRY



BRASS CLAMPS FOR CURVED LINES

BRASS CORNER QUADS

Perfectly Square Inside and Outside.

SOLID BRASS. NOT BRAZED.

40 cents per set.

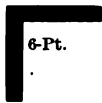

6-Pt.

Full Size.

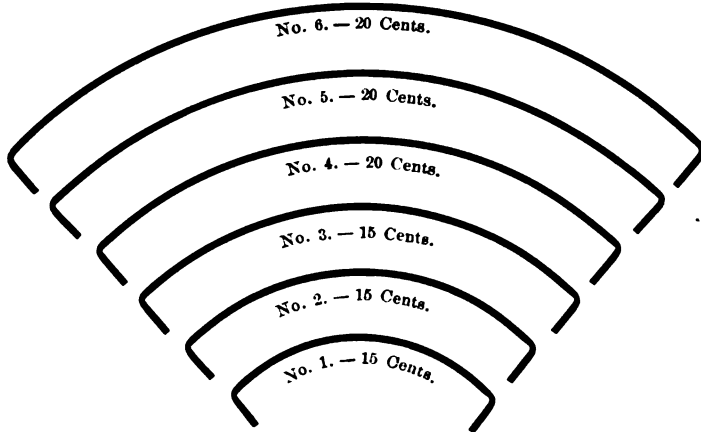

BRASS CORNER QUADS

Perfectly Square Inside and Outside.

SOLID BRASS. NOT BRAZED.

40 cents per set.

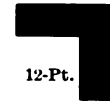

12-Pt.

Full Size.

Nos. 18 to 43, 20 cents each.

BRASS FLOURISHES

Nos. 61 to 75, 10 cents each

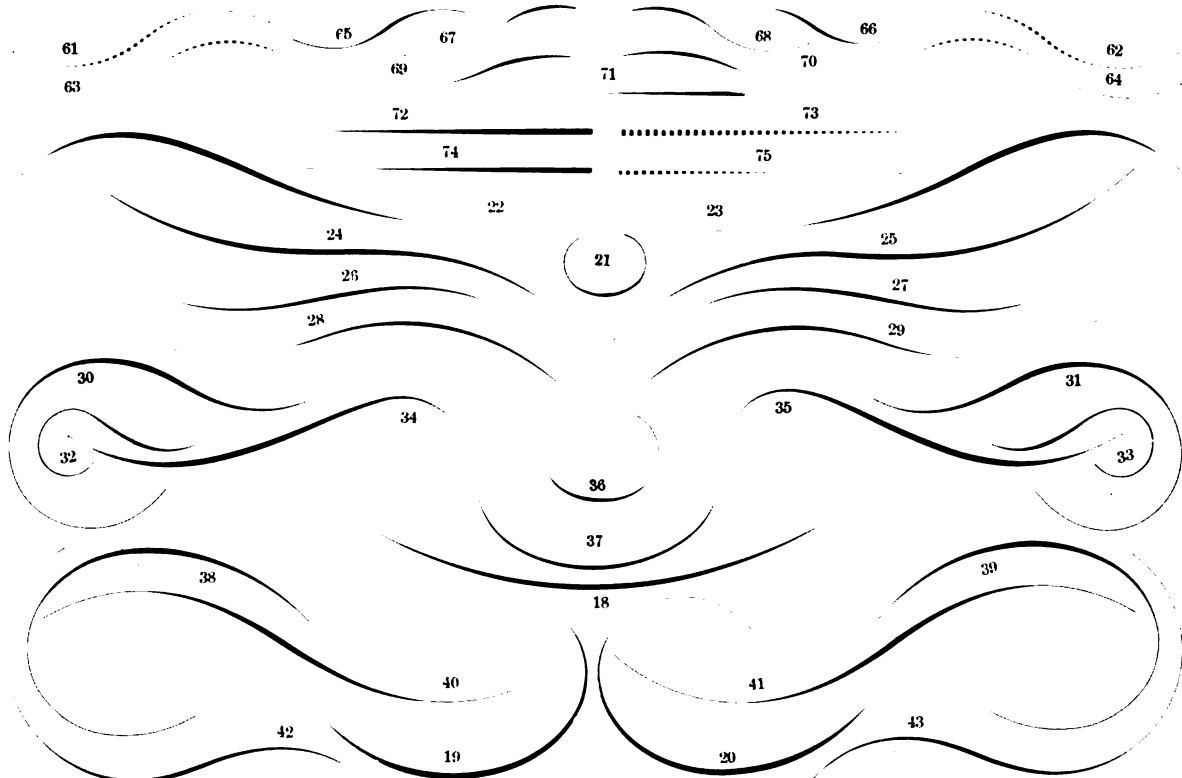

BRASS DASH CORNERS. Per set of four, 60 cents

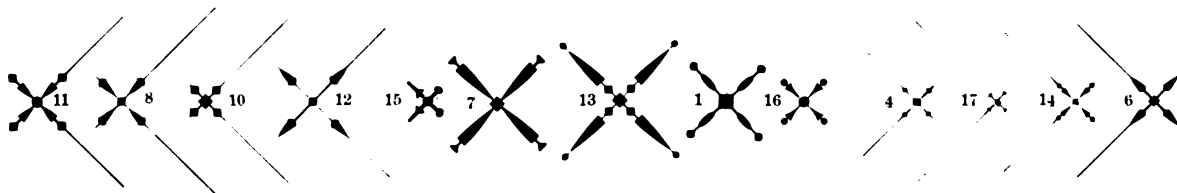

THE H. C. HANSEN TYPE FOUNDRY

BRASS POINTERS

Plain: 6-Point, 10 cents each; 8-Point, 15 cents each; 12-Point, 20 cents each. Fancy, 5 cents extra

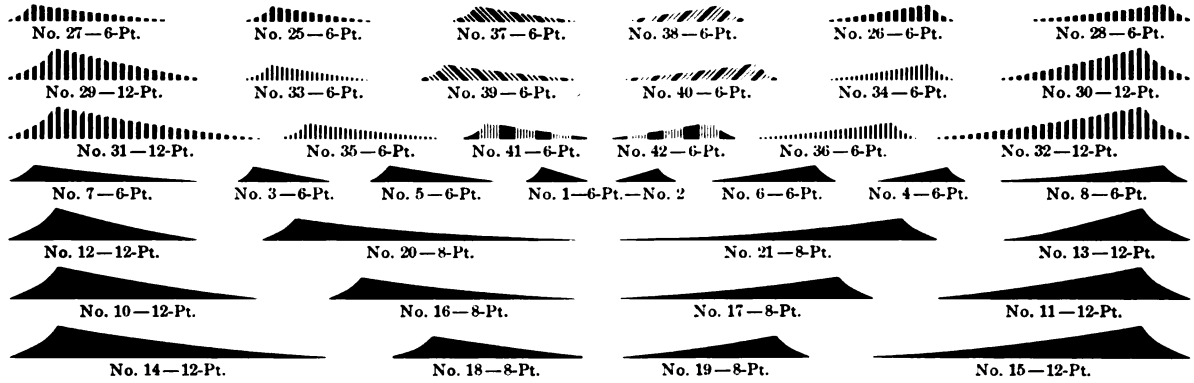

METAL RULE

18-inch strips		Per Foot
	2-Pt.	5 cts.
	3-Pt.	8 cts.
	4-Pt.	10 cts.
	5-Pt.	12 cts.
No. 1	6-Pt.	15 cts.
No. 2	8-Pt.	20 cts.
No. 3	12-Pt.	30 cts.

18-inch strips		Per Foot
No. 5	18-Pt.	45 cts.
No. 6	24-Pt.	60 cts.
No. 7	18-Pt.	45 cts.
No. 8	24-Pt.	60 cts.

18-inch strips		Per Foot
No. 9	12-Pt.	45 cts.
No. 10	18-Pt.	70 cts.
No. 11	24-Pt.	85 cts.

BRASS CIRCLES AND OVALS

Circles	No.	Price	Ovals	No.	Price
	3 697	\$0.90		3 697	\$1.45
	4 699	1.25		4 699	1.90
	6 709	1.25		6 709	1.90
	6 700	1.60		6 700	2.35
	5 704	1.60		5 704	2.35

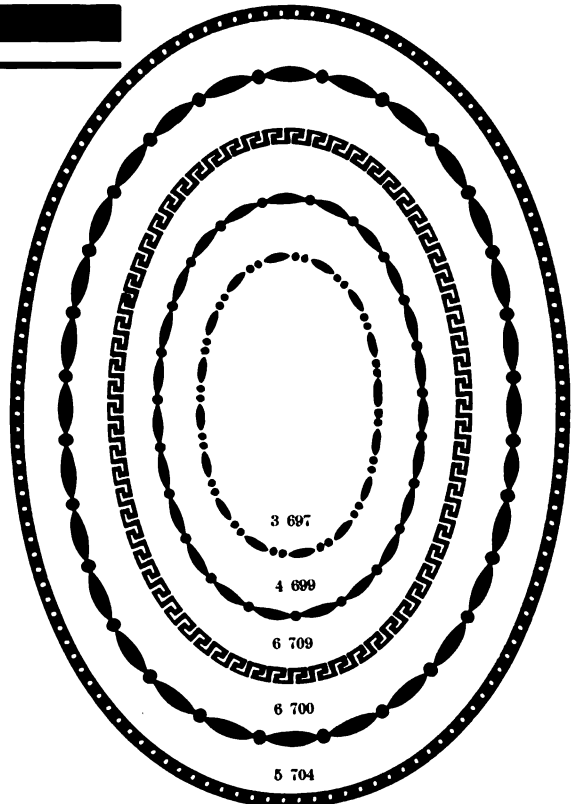
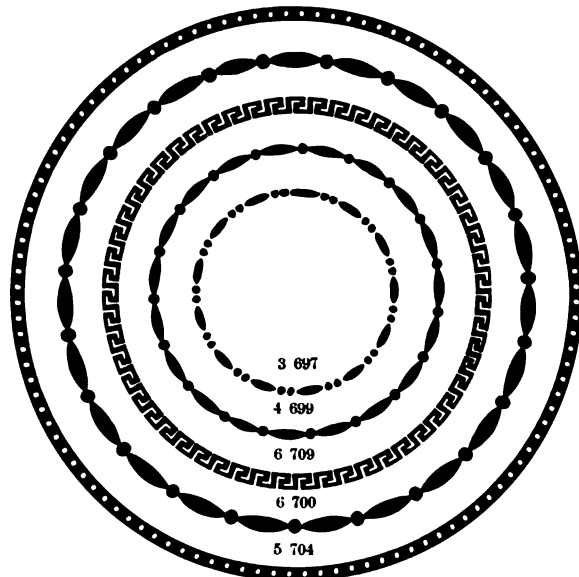

THE H. C. HANSEN TYPE FOUNDRY



BRASS CIRCLES

Circles and Ovals of any Size or Face Made to Order

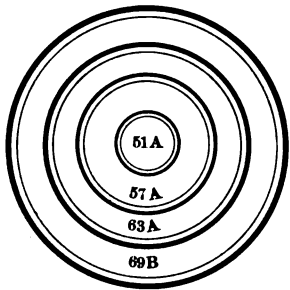

No.	Price.
51A	\$0.35
52A35
53A35
54A35
57A50
58A50
59A50
60A50

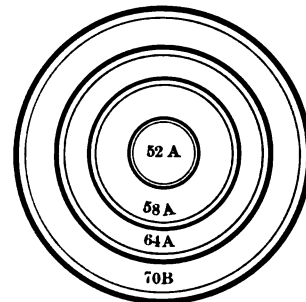

No.	Price.
63A	\$0.75
64A75
65A75
66A75
69B	1.00
70B	1.00
71B	1.00
72B	1.00

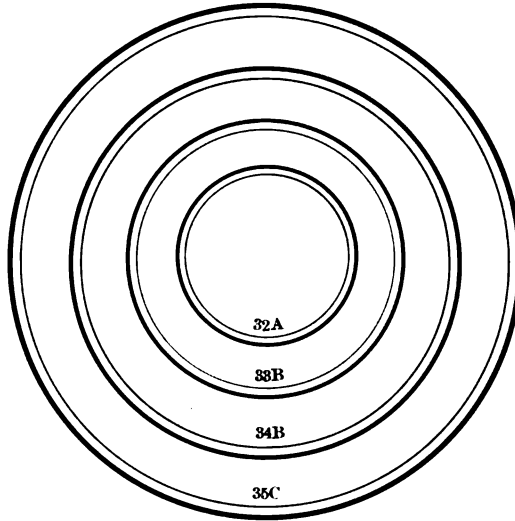

No.	Price.
32A	\$0.75
33B	1.00
34B	1.00
35C	1.25

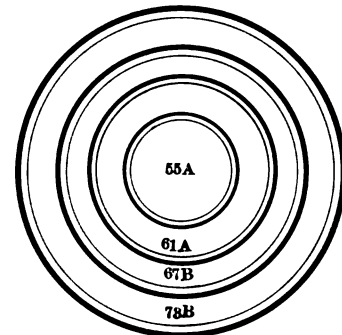
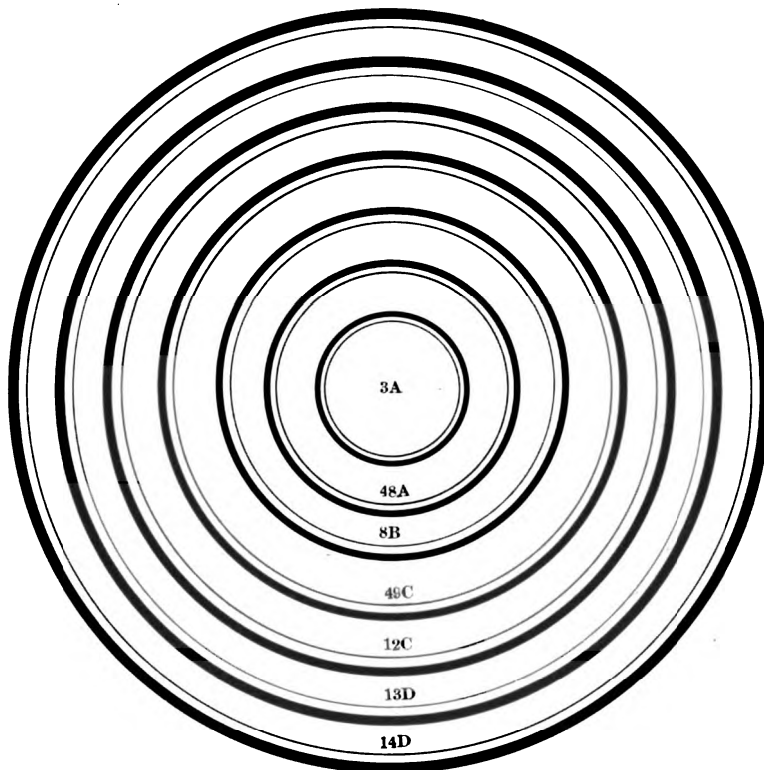
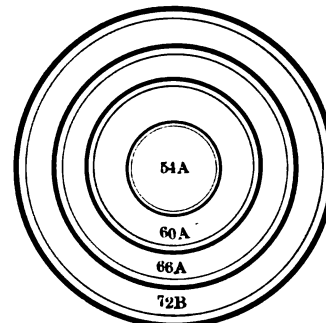
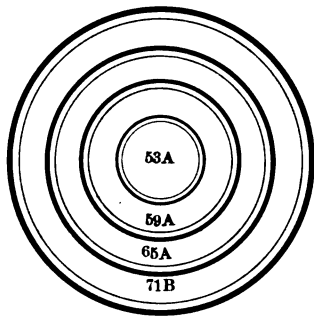

Nos. 50A and 51A	\$0.35
Nos. 3A, 55A and 56A50
Nos. 48A, 61A and 62A75
Nos. 8B, 67B, 68B, 73B and 74B	1.00
Nos. 12C and 49C	1.25
Nos. 13D and 14D	1.50

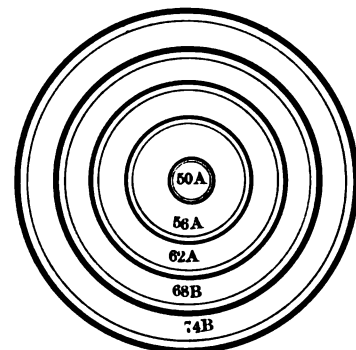

THE H. C. HANSEN TYPE FOUNDRY

H. C. HANSEN'S BRASS CIRCLES

Circles and Ovals any size or face made to order

We make brass rules to match all circles.

Special prices on four or more of one size and kind ordered at one time.

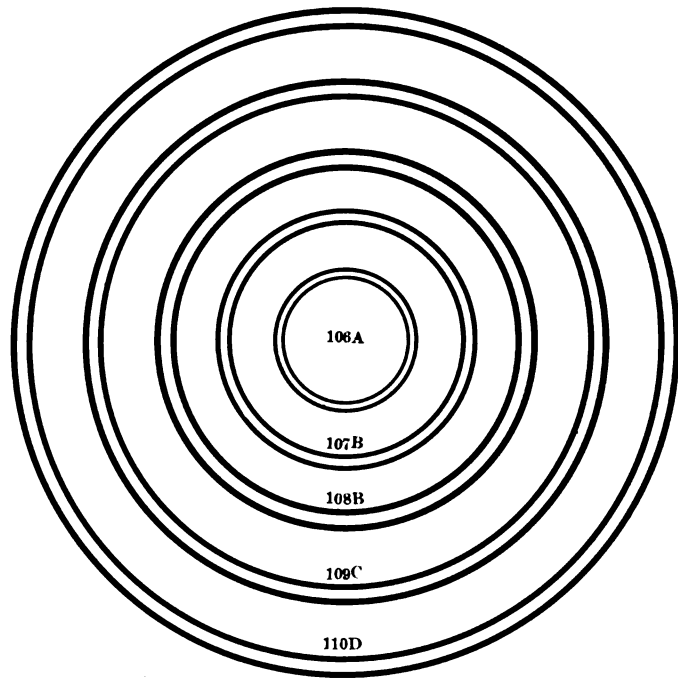
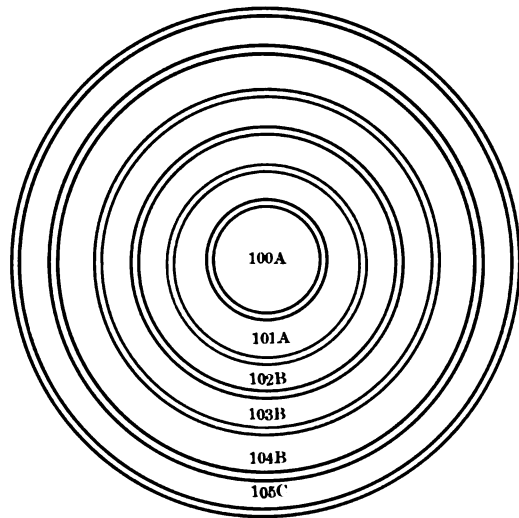

No. 100A	\$0.50	No. 106A	\$0.50
" 101A75	" 107B	1.00
" 102B	1.00	" 108B	1.00
" 103B	1.00	" 109C	1.25
" 104B	1.00	" 110D	1.50
" 105C	1.25		

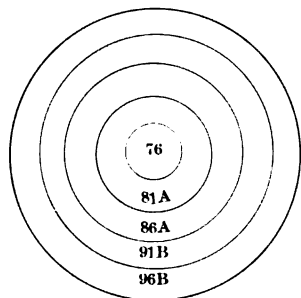

No.	Price	No.	Price
1A	\$0.50	78A	\$0.35
4A75	79A35
6B	1.00	80A50
9B	1.00	81A50
11C	1.25	82A50
7535	83A75
7635	84A50
77A35	85A75

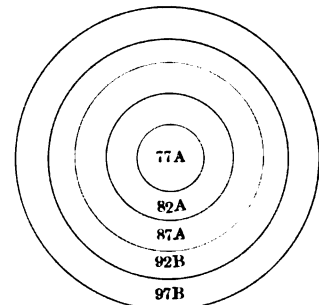
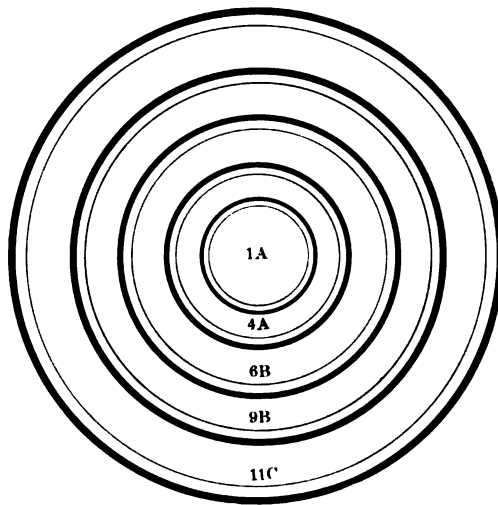

No.	Price	No.	Price
86A	\$0.75	93B	\$1.00
87A75	94B	1.00
88A75	95B	1.00
89A75	96B	1.00
90A75	97B	1.00
91B	1.00	98B	1.00
92B	1.00	99B	1.00

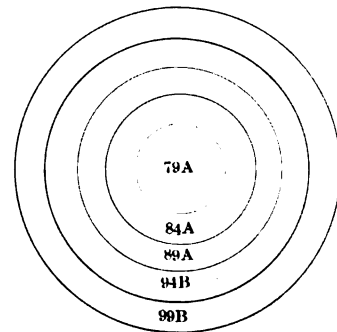
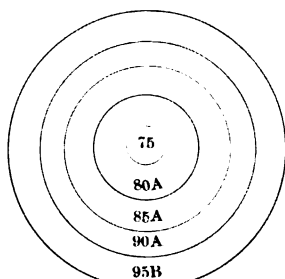
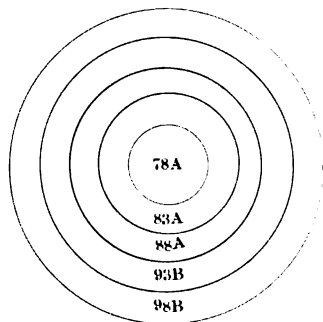

THE H. C. HANSEN TYPE FOUNDRY

H. C. HANSEN'S

BRASS CIRCLES AND OVALS

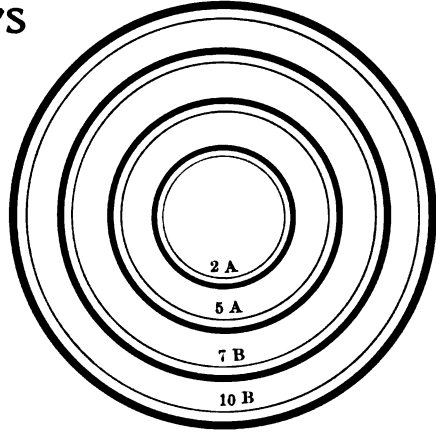
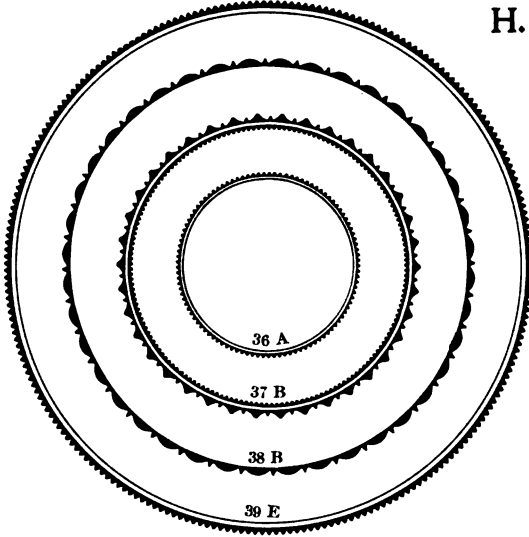

No.	Price.
2A	\$.50
5A75
7B	1.00
10B	1.00
15C	1.20
16C	1.35
20A75
24A75
25B	1.00
26B	1.00
30B	1.00
36A90
37B	1.25
38B	1.25
39E	1.60

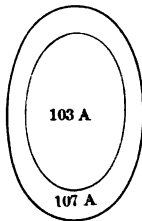
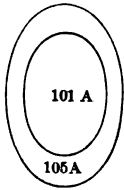
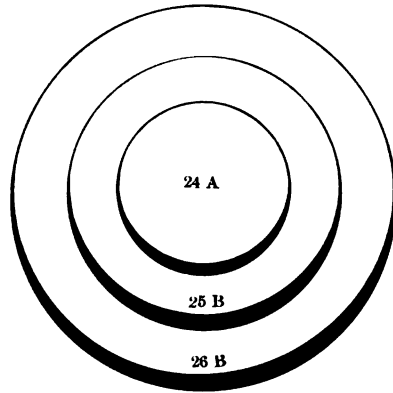
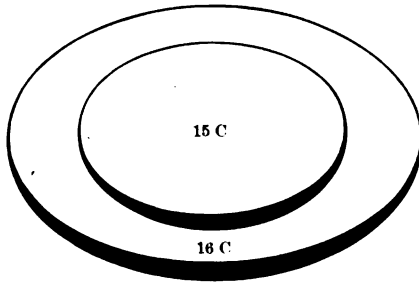
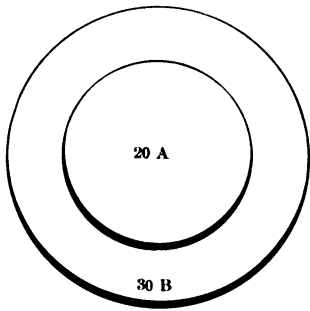

Nos. 100 to 108, and 116 to 124
90 cents each.

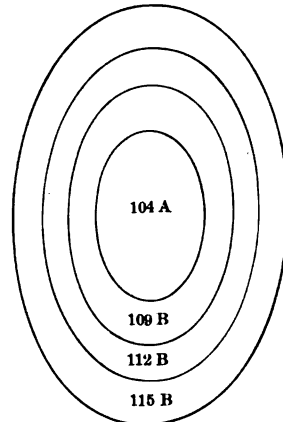
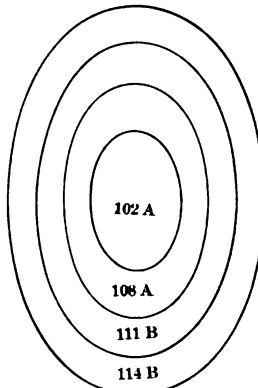
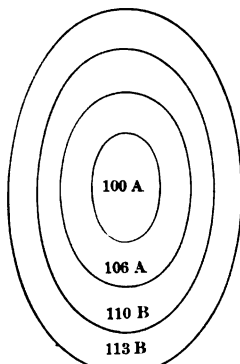

Nos. 109 to 115, and 125 to 131
\$1.20 each.

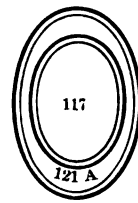
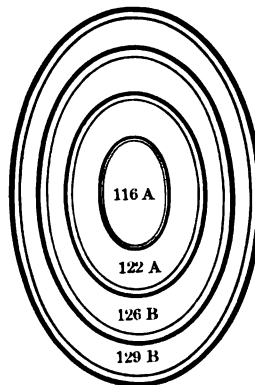
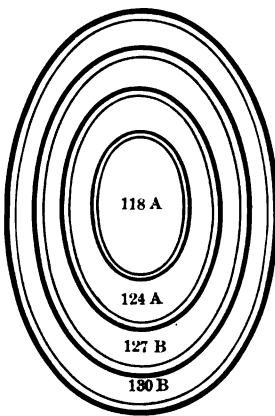
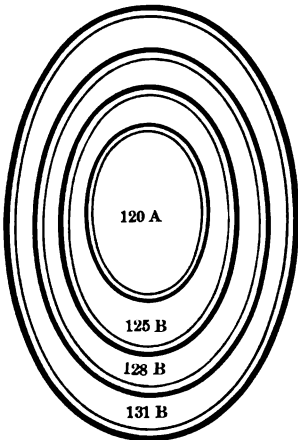

THE H. C. HANSEN TYPE FOUNDRY



BRASS OVALS

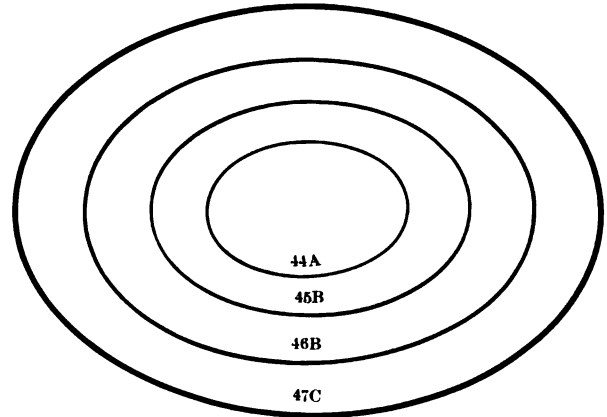
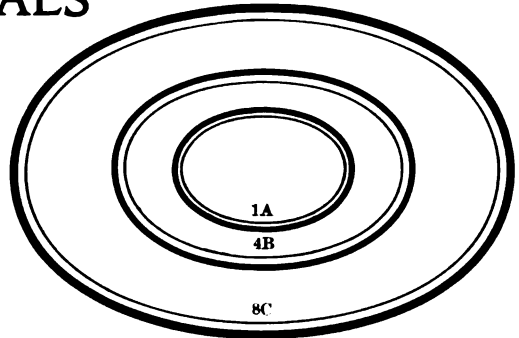
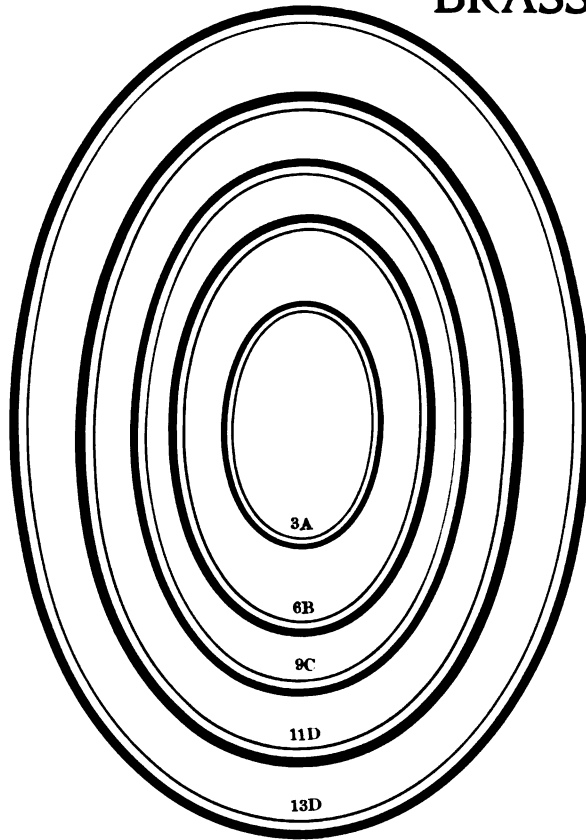

No.	Price	No.	Price
50A	\$0.90	54D	\$1.80
51B	1.20	55F	1.45
52C	1.50	56F	1.45
53C	1.50	57G	1.90

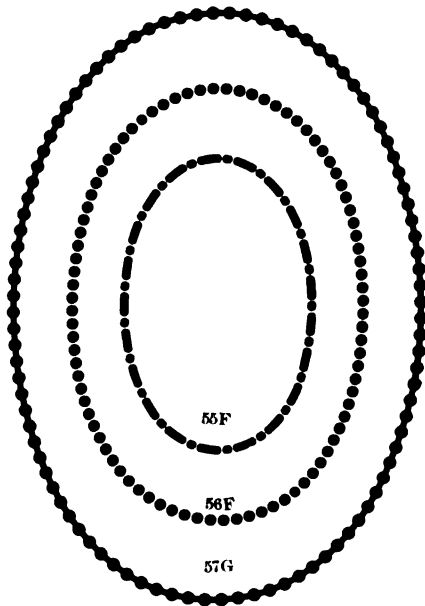

No.	Price
1A	\$0.90
3A90
4B	1.20
6B	1.20
8C	1.50
9C	1.50
11D	1.80
13D	1.80
44A90
46B	1.20
46C	1.50
47C	1.50

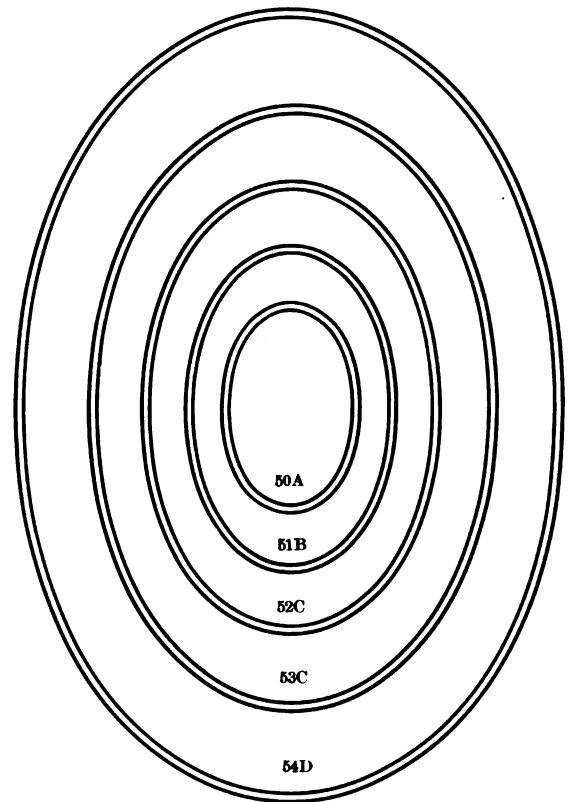

THE H. C. HANSEN TYPE FOUNDRY



BRASS OVALS

Ovals of any
Size or Face
made to Order

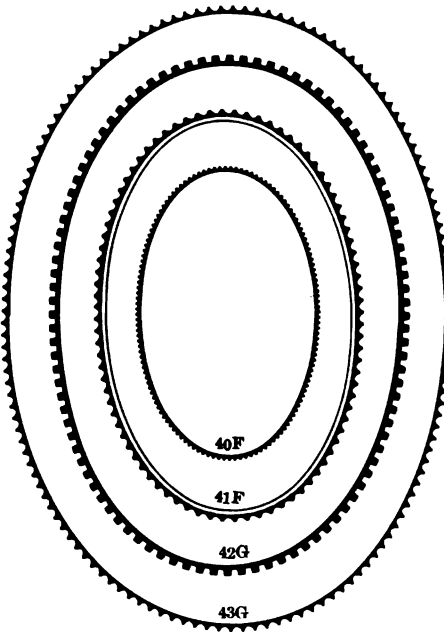
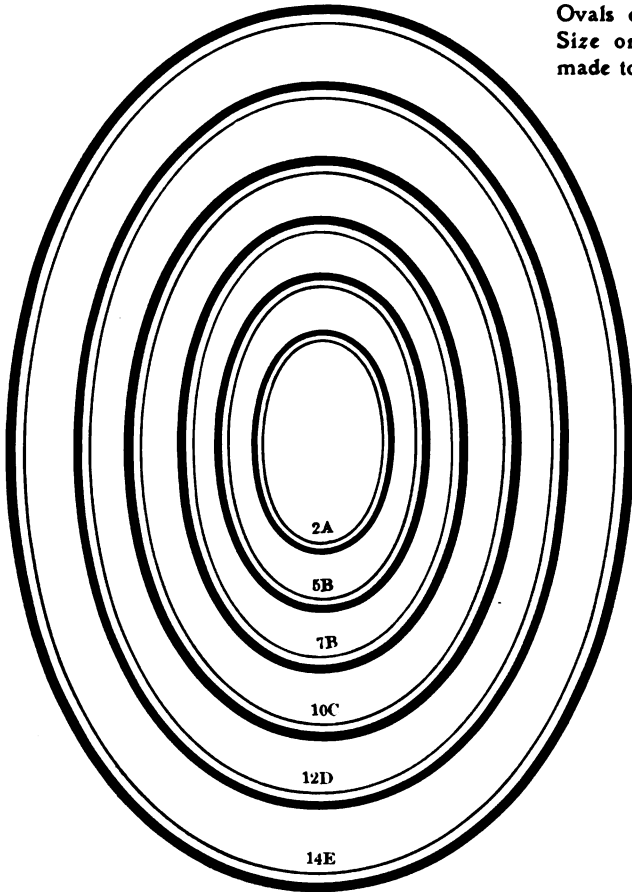

No.	Price
2A	\$0.90
5B	1.20
7B	1.20
10C	1.50
12D	1.80
14E	2.10
40F	1.45
41F	1.45
42G	1.90
43G	1.90

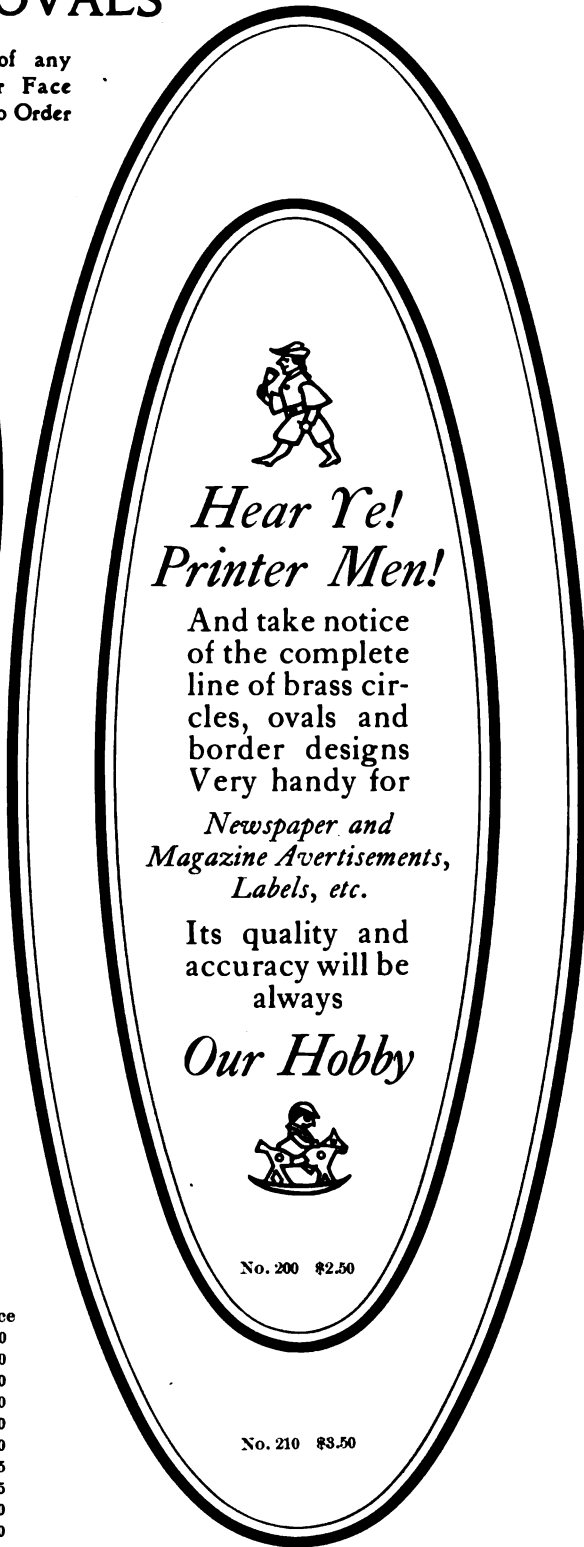

THE H. C. HANSEN TYPE FOUNDRY



BRASS RULE BORDER DESIGNS

BLOCKED SOLID IN METAL

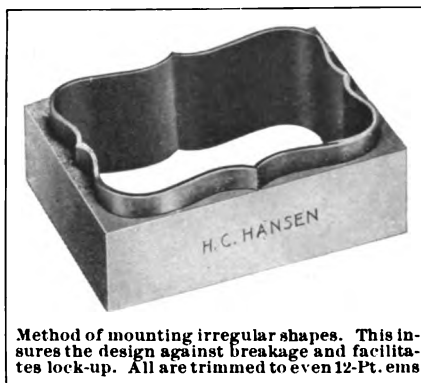
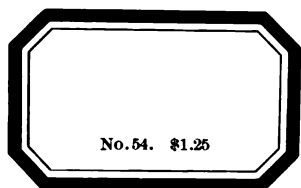
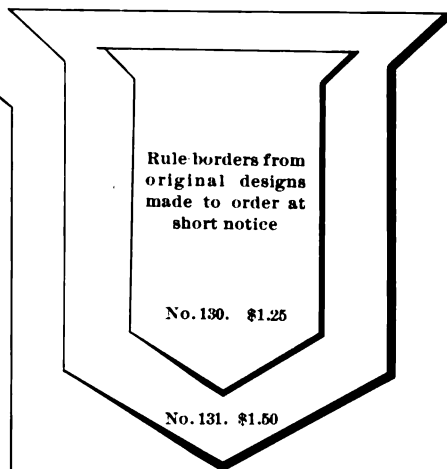
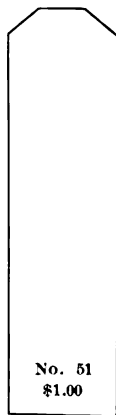
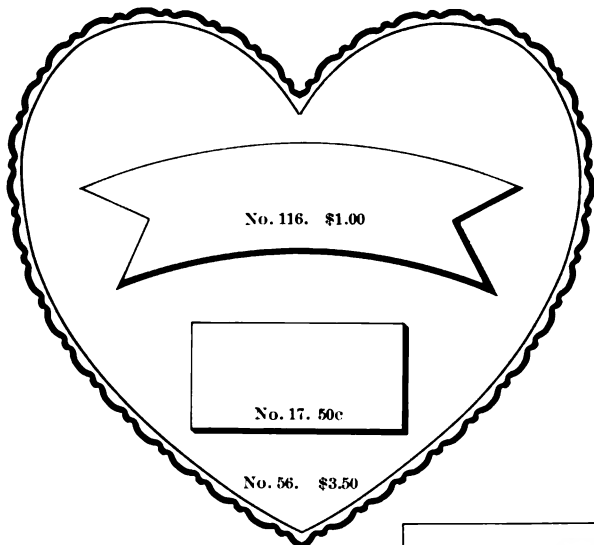

Method of mounting irregular shapes. This insures the design against breakage and facilitates lock-up. All are trimmed to even 12-Pt. ems

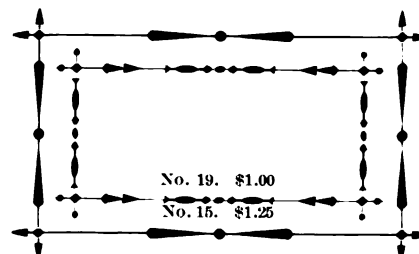
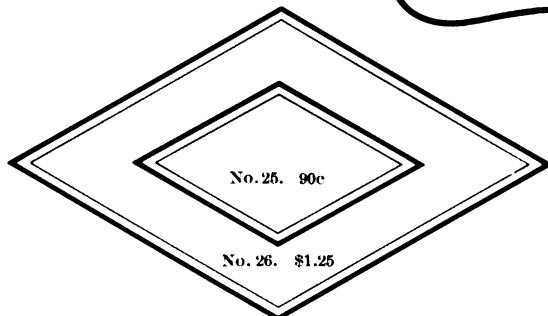
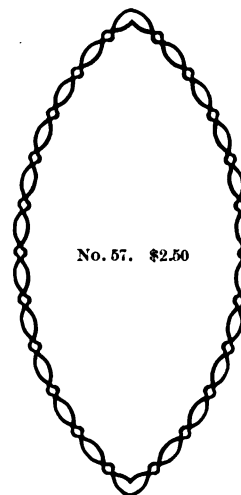
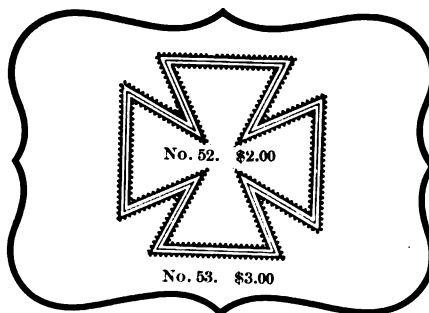
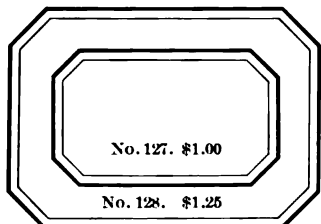
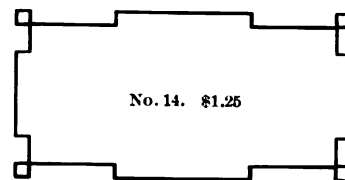

THE H. C. HANSEN TYPE FOUNDRY



HANSEN'S SOLID BRASS CORNERS

These Corners Match accurately rule faces of corresponding number

When ordering state size of body, face and number

6-Point Body

Price, Per Set of Four, \$0.30

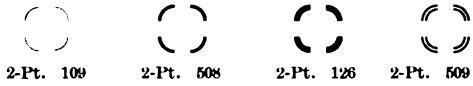

12-Point Body

Price, Per Set of Four, \$0.35

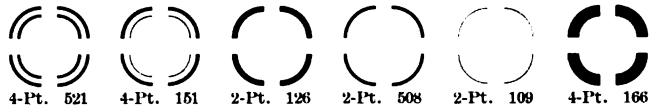

18-Point Body

Price, Per Set of Four, \$0.50

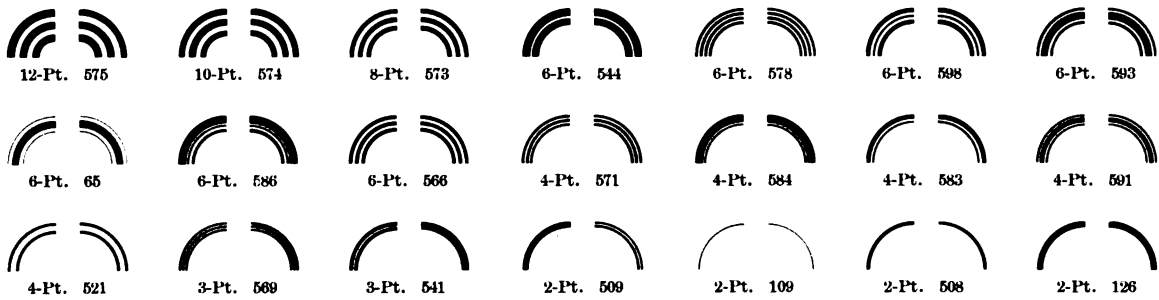

24-Point Body

Price, Per Set of Four, \$0.60

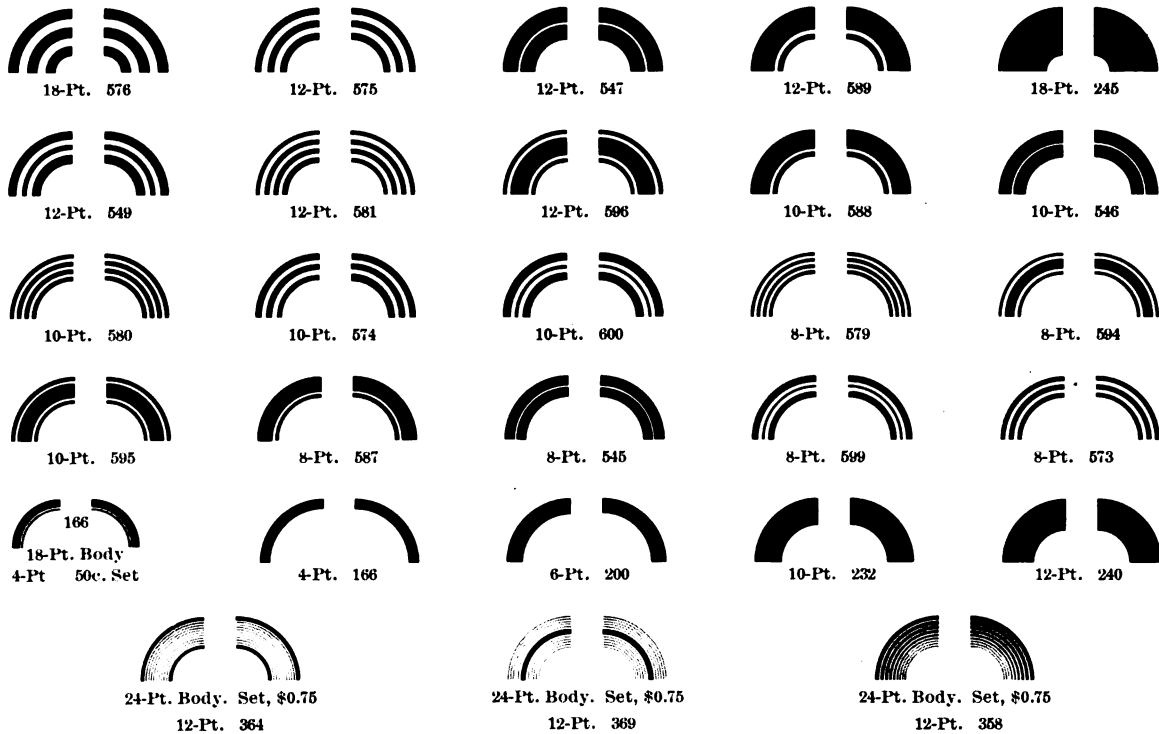

THE H. C. HANSEN TYPE FOUNDRY



HANSEN'S ROUND BRASS CORNERS

ORIGINATED BY H. C. HANSEN

DO NOT MUTILATE THIS BOOK. ORDER BY BODY AND NUMBER. PRICES ON PAGE 249

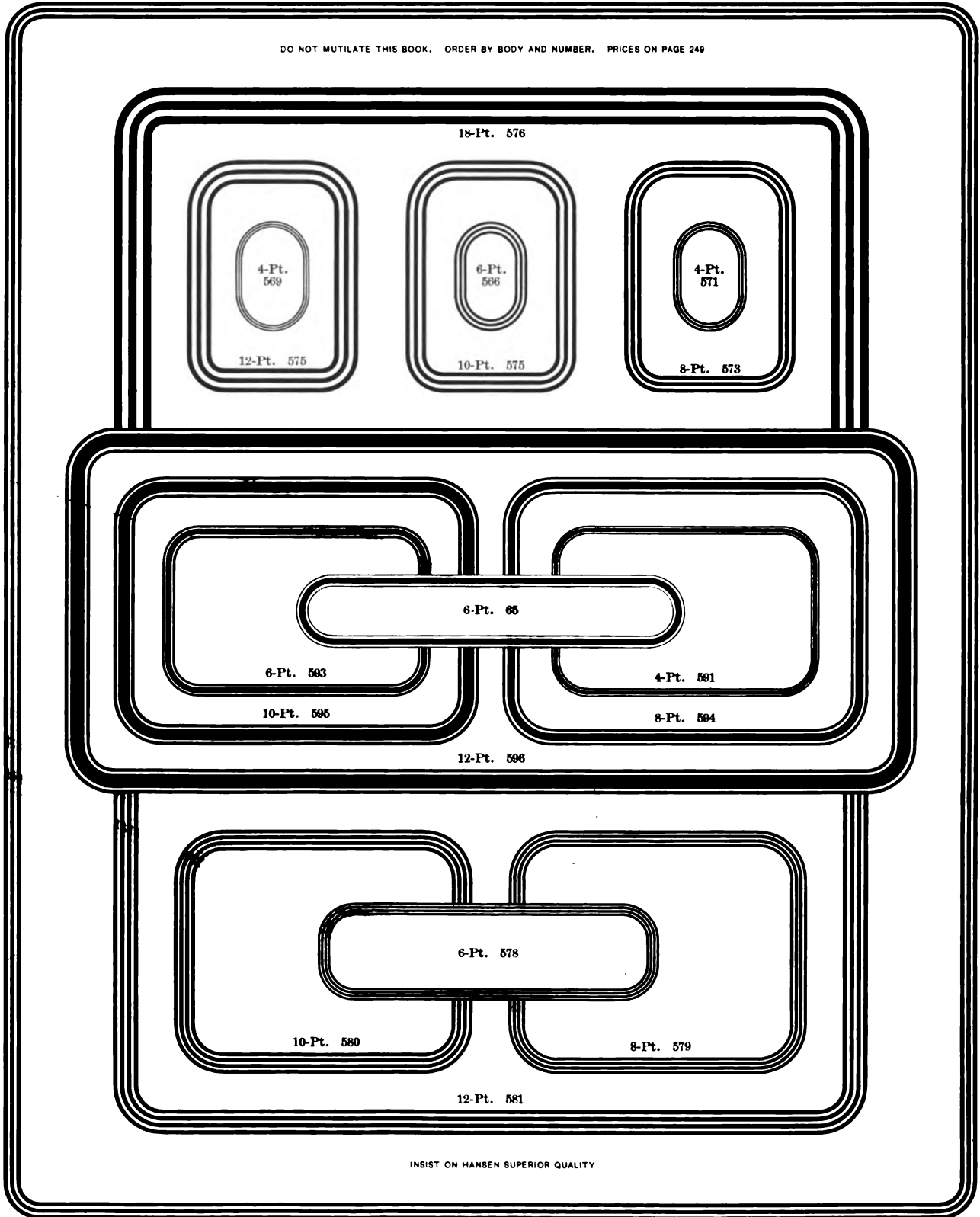

THE H. C. HANSEN TYPE FOUNDRY



HANSEN'S ROUND BRASS CORNERS

ORDER BY BODY AND NUMBER

PRICES ON PAGE 248

The solid brass corners were originated by the H. C. Hansen Type Foundry

They are absolutely accurate in height and body

12-Pt. 589

3-Pt. 541

4-Pt. 584

10-Pt. 588

6-Pt. 586

3-Pt. 583

8-Pt. 587

2-Pt. 508

2-Pt. 126

6-Pt. 544

10-Pt. 546

8-Pt. 545

12-Pt. 358

4-Pt. 152

12-Pt. 547

4-Pt. 521

2-Pt. 509

12-Pt. 364

8-Pt. 589

6-Pt. 588

10-Pt. 600

12-Pt. 54

2-Pt. 109

12-Pt. 369

These corners will match accurately rule faces of the same number

THE H. C. HANSEN TYPE FOUNDRY





HANSEN'S BRASS DIAGONAL CORNERS

When ordering, give size of body and number of corner

 8 434
 12-Pt. Body

 8 126
 12-Pt. Body

 8 145
 12-Pt. Body

 8 166
 12-Pt. Body

 8 200
 12-Pt. Body

PRICES

—

1, 2, 3, 4 and 6-Pt. face on 12 and 18-Point bodies, per set, \$0.35

—

4, 6, 8 and 12-Pt. face on 24-Point body, per set \$0.50

—

Parallel Diagonal Corners

4, 6, 8 and 12-Point face on 24-Point body, per set \$0.75



 15 240
 24-Pt. Body



 15 221
 24-Pt. Body

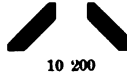

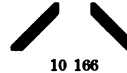
 15 200
 24-Pt. Body

 15 166
 24-Pt. Body

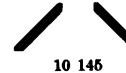

 10 200
 18-Pt. Body

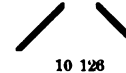

 10 166
 18-Pt. Body



 10 145
 18-Pt. Body



 10 128
 18-Pt. Body

The last three figures signifies the number of rule which may be used with these corners

 15 544
 24-Pt. Body

 15 542
 24-Pt. Body

 15 547
 24-Pt. Body

 15 545
 24-Pt. Body

THE H. C. HANSEN TYPE FOUNDRY



HANSEN'S SOLID BRASS CORNERS. (Mortised)

ORIGINATED BY H. C. HANSEN

These corners match accurately face rule of corresponding size

When ordering state size of body, face and number

ROUND CORNERS

Price, Per Set of Four, \$0.50



ALL CORNERS SHOWN HERE ← → ONE PIECE OF BRASS

COMBINATION CORNERS

Price, Per Pair, \$0.30

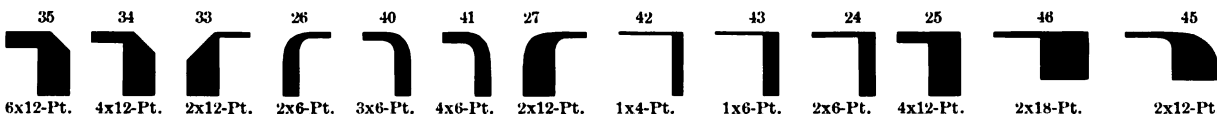

All the above corners are mortised to even points to facilitate rapid justification

SOLID BRASS ← → NOT BRAZED

SQUARE CORNERS

Price, Per Set of Four, \$0.50



These corners are mortised to match 2, 3, 4, 5, 6, 8 and 12-Pt. brass rule. The number of each corresponds to number of Hansen's rule which is to be used. Rule can be furnished either in strips or labor-saving fonts. We make corners to match our parallel or double rule. Corners, Per Set of Four, indicated by letter A, \$0.60; B, \$0.80; C, \$0.90; D, \$1.00

A 2-Pt. No. 109	A 2-Pt. No. 508	B 2-Pt. No. 509	A 3-Pt. No. 133	B 3-Pt. No. 441	B 3-Pt. No. 442
B 4-Pt. No. 521	B 4-Pt. No. 4 542	B 4-Pt. No. 150	B 4-Pt. No. 152	B 5-Pt. No. 171	B 5-Pt. No. 172
B 6-Pt. No. 186	B 6-Pt. No. 522	C 6-Pt. No. 6 566	B 6-Pt. No. 6 544	B 6-Pt. No. 6 544 A	C 6-Pt. No. 6 598
C 6-Pt. No. 6 593	B 6-Pt. No. 6 586	D 8-Pt. No. 8 573	D 8-Pt. No. 8 594	B 8-Pt. No. 8 587	D 8-Pt. No. 8 599
D 12-Pt. No. 12 596	D 12-Pt. No. 12 549	D 12-Pt. No. 12 575	C 12-Pt. No. 12 589	C 12-Pt. No. 12 547	C 12-Pt. No. 12 547A

These corners are each made of one piece of solid brass and not brazed. They are the only corners that will resist any strain and not break. They are invaluable for newspaper use.

THE H. C. HANSEN TYPE FOUNDRY



HANSEN'S SOLID BRASS CENTRE PIECES

Price, Per Pair, \$0.50

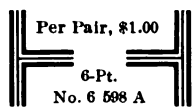
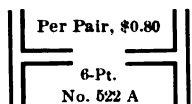
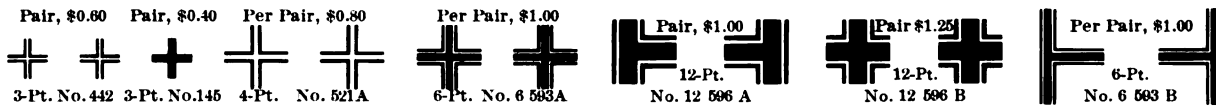
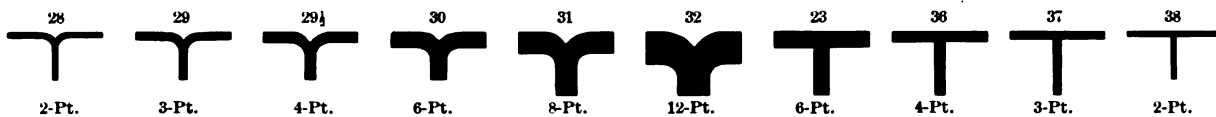

**RULE
PANELS**

$\frac{1}{2}$

BRASS FRACTIONAL MARKS
Price, 50c each

Valuable for setting odd fractions

**EASILY
MADE**

$\frac{12}{45}$

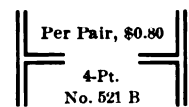
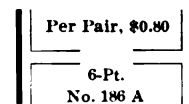

HANSEN'S BRASS BRAZED CORNERS

These corners match accurately rule faces of corresponding number

When ordering, state size of body, face and number

These corners measure 2x4 ems pica long.

Prices, per set of four, 2, 3, 4 or 6-Pt., \$0.50; 8, 10 or 12-Pt., \$0.60

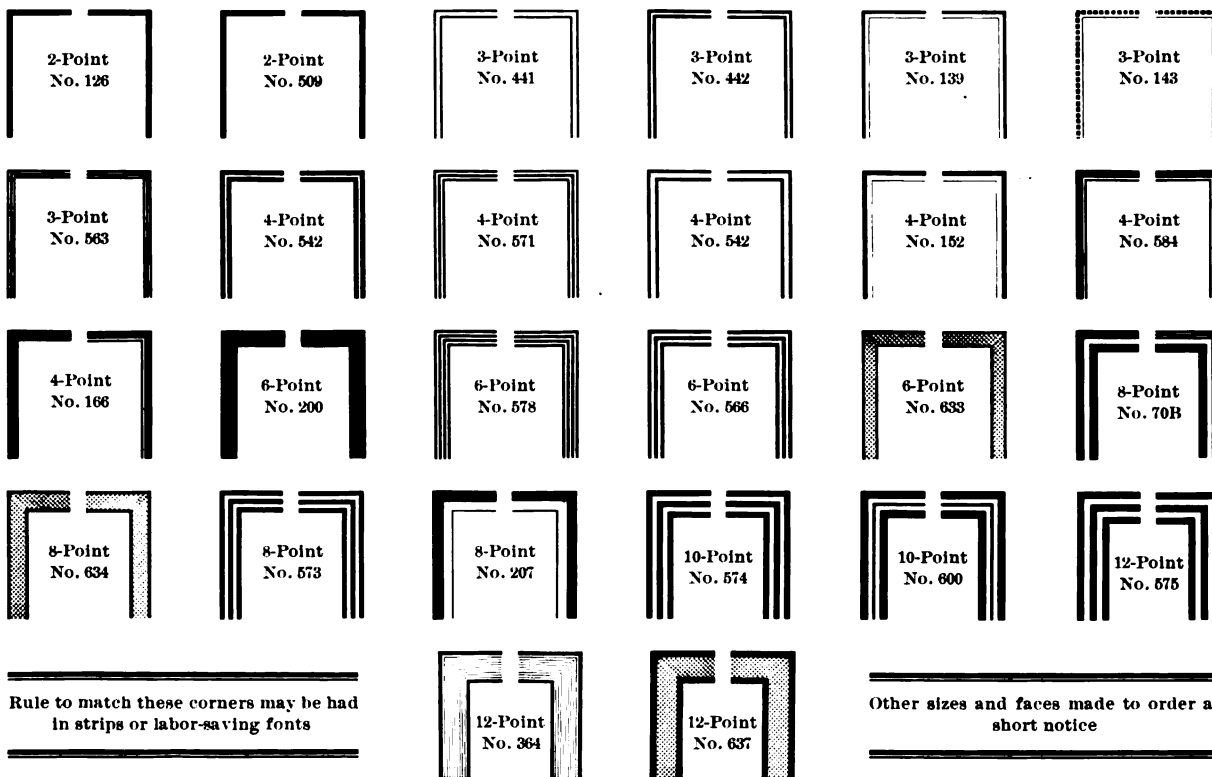

Rule to match these corners may be had in strips or labor-saving fonts

Other sizes and faces made to order at short notice

THE H. C. HANSEN TYPE FOUNDRY



HANSEN'S SLOTTED BRASS CORNERS

These corners match accurately rule faces of corresponding number

When ordering, state size of body, face and number

Prices, per set of four, 2, 3, 4 or 6-Pt., \$0.50; 8 or 10-Pt., \$0.65 Larger sizes and other faces to order

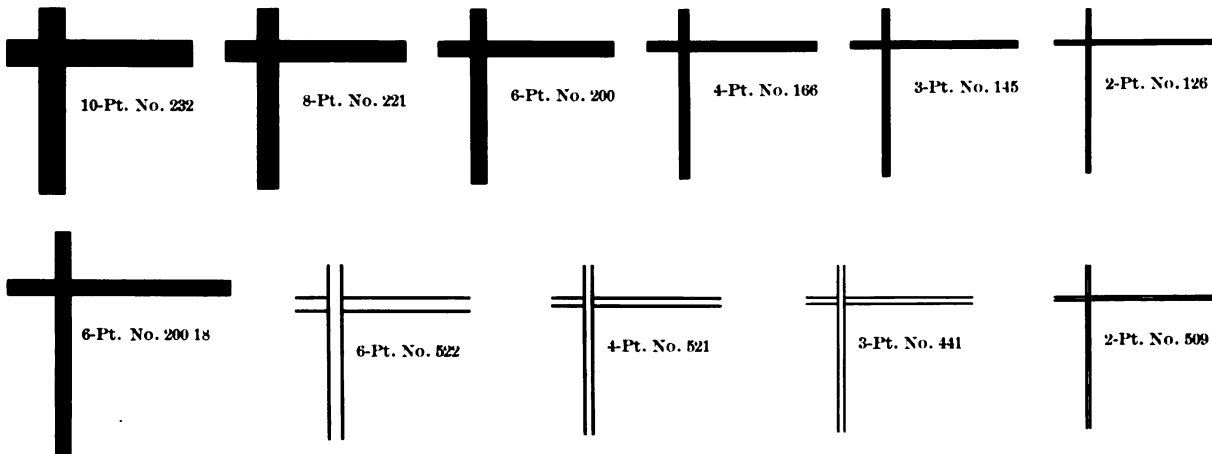

HANSEN'S BRASS INITIAL RULES

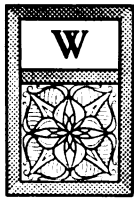

No. 1

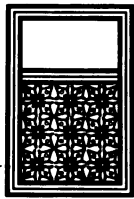

No. 2

*These initial rules enable the printer to produce initials in many different styles and sizes as may suit his individual taste.

Put up in fonts of 6 and 12-point rules of 4 pieces each, mitered 4 ems and 6 ems outside, and 2 center cross rules.

Six-point fonts contain styles Nos. 1, 2, 3, 4, 5, 6, 7, 8, 12 and 16 (contains 80 mitered and 20 cross pieces) \$7.00
 Half font, 5 styles, \$3.60. Single set, 0.45
 Twelve-point fonts contain styles Nos. 9, 10, 11, 14 and 15 (contains 40 mitered and 10 cross pieces) \$6.00
 Small font, 3 styles, \$4.00 Single set, 0.60



No. 3

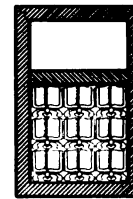

No. 4



No. 5



No. 6



No. 7

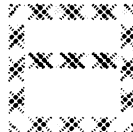

No. 8

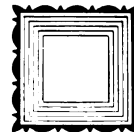

No. 9



No. 10

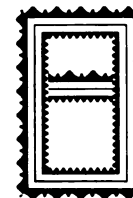

No. 11



No. 12

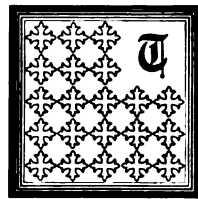

No. 13

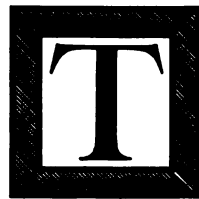

No. 14



No. 15



No. 16

*Letters and ornaments do not go with rule fonts. Rules only are furnished

THE H. C. HANSEN TYPE FOUNDRY



HANSEN'S SOLID BRASS CENTRE PIECES

Price, Per Pair, \$0.50

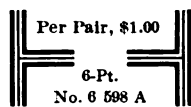
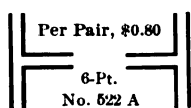
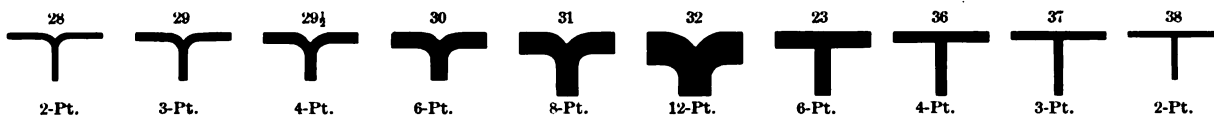

**RULE
PANELS**

1/2

BRASS FRACTIONAL MARKS
Price, 50c each

Valuable for setting odd fractions

**EASILY
MADE**

12/45

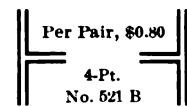
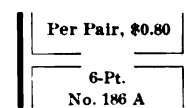

HANSEN'S BRASS BRAZED CORNERS

These corners match accurately rule faces of corresponding number

When ordering, state size of body, face and number

These corners measure 2x4 ems pica long.

Prices, per set of four, 2, 3, 4 or 6-Pt., \$0.50; 8, 10 or 12-Pt., \$0.60

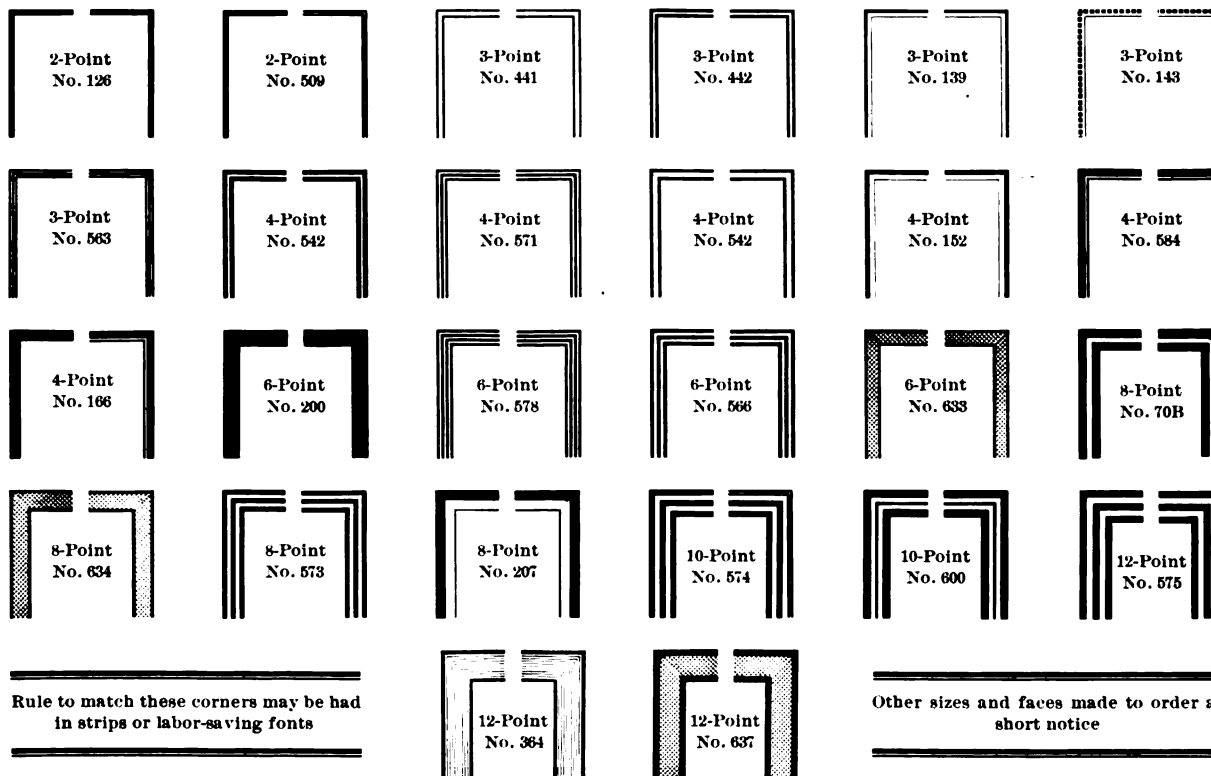

Rule to match these corners may be had in strips or labor-saving fonts

Other sizes and faces made to order at short notice

THE H. C. HANSEN TYPE FOUNDRY



HANSEN'S SLOTTED BRASS CORNERS

These corners match accurately rule faces of corresponding number

When ordering, state size of body, face and number

Prices, per set of four, 2, 3, 4 or 6-Pt., \$0.60; 8 or 10-Pt., \$0.65 Larger sizes and other faces to order

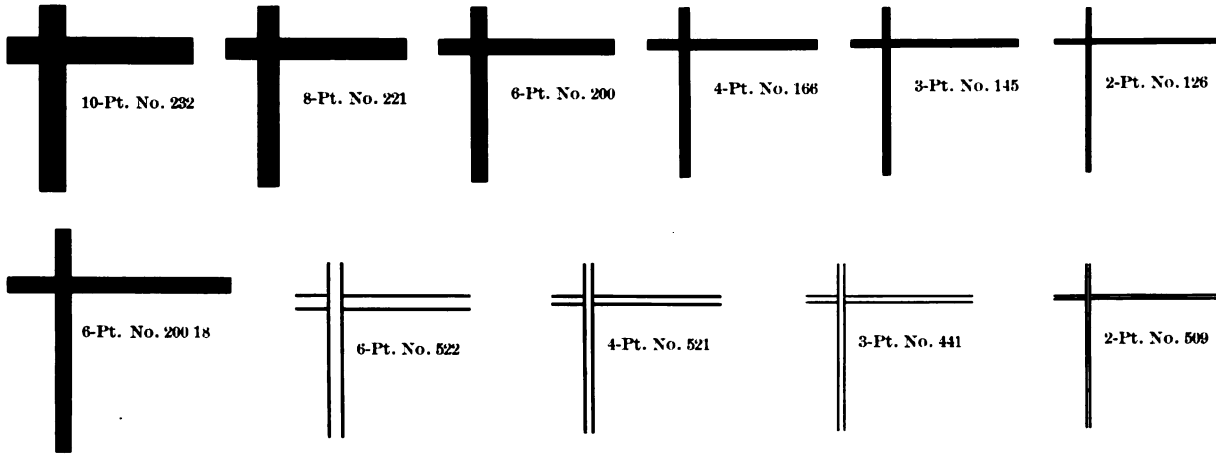

HANSEN'S BRASS INITIAL RULES

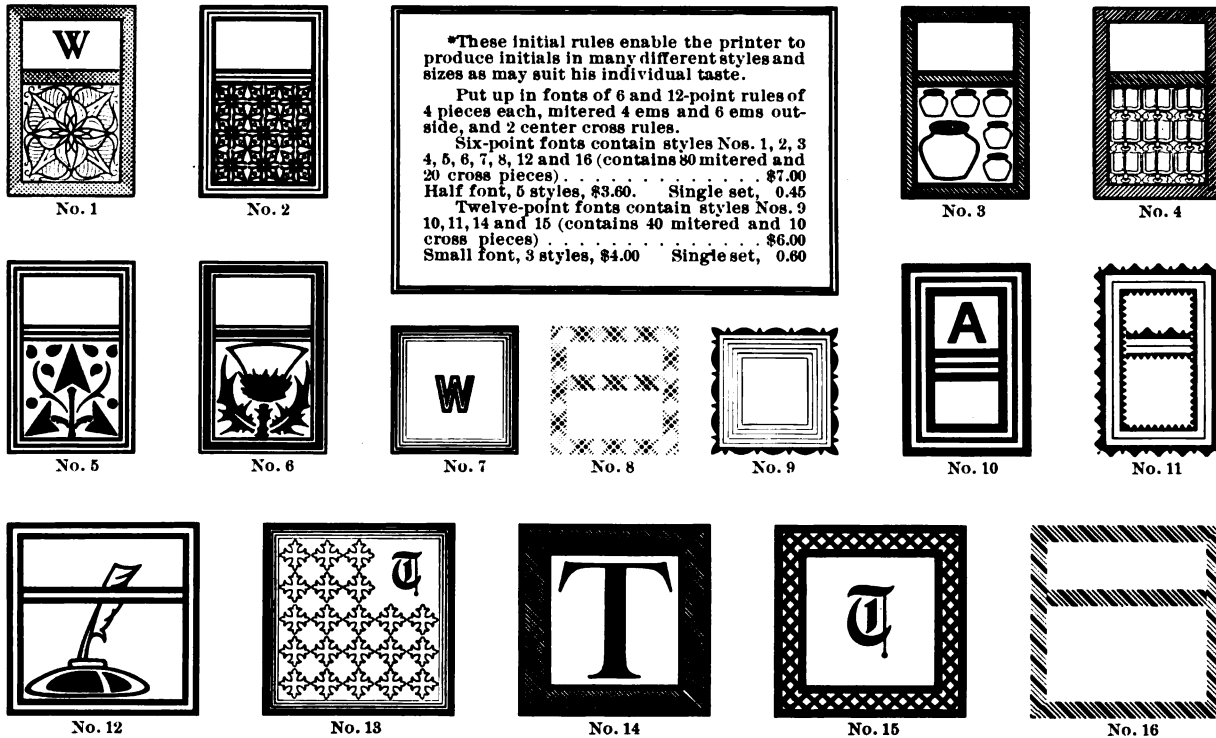

*Letters and ornaments do not go with rule fonts. Rules only are furnished

THE H. C. HANSEN TYPE FOUNDRY

S O M E T H I N G N E W
**HANSEN'S
 BEVELED QUOTATIONS AND QUADS**

Invented by H. C. Hansen (Patent applied for)

CAST ON ANGLES OF 45, 54, 60, 72 AND 78 DEGREES

NO PRINTING OFFICE SHOULD BE WITHOUT A FONT

The standard five angles cast give also angles of 36°, 30°, 18° and 12° as well the right angle or 90°.

Special Font in a Quarter-size case (shown on page 378) containing 45°, 54° and 60°, complete with case, \$12.00
 Advantageous for large offices.

THE HANSEN BEVELED QUADS AND QUOTATIONS supply a long-felt need, as they render artistic and complicated set-ups as rapid and easy to the job compositor as straight composition. Being made on five different angles they allow a variety of arrangement and a pleasing relief from the straight and ordinary appearance which printers have been forced to produce on account of the extra time and expense heretofore necessary to do work of this

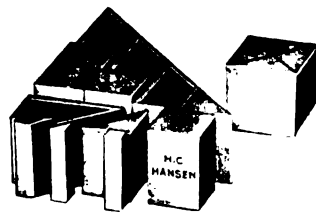

SHOWING THE ANGLE OF 45 DEGREES

kind. The Beveled Quads and Quotations completely do away with the necessity of using Plaster Paris after the form is set up, as is nearly always necessary when ordinary quads and leads are used for justification. A slanting panel or line justified



SHOWING THE ANGLE OF 54 DEGREES

with these quads is as secure and may be lifted as easily as a form of straight matter. The illustration shown below gives a clear idea of the utility of these quads and quotations and one glance will readily convince the printer of the practicability and value of them to the man who desires to do the "just a little different" style of printing which begets trade.

In the advertising departments of newspapers and other publications they will fill a long felt want,

and for the printer of labels their many uses make them simply invaluable.

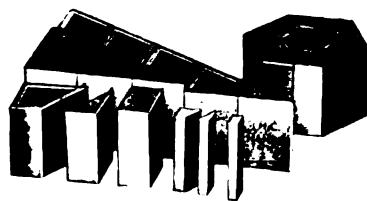

SHOWING THE ANGLE OF 60 DEGREES

Degree is stamped on each piece.

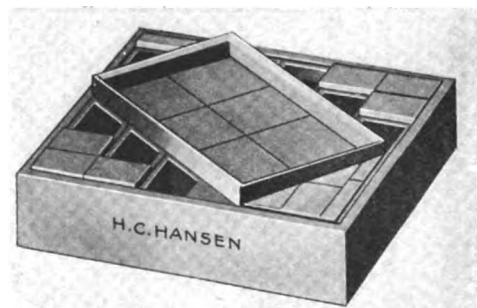

SHOWING FORM JUSTIFIED WITH HANSEN'S BEVELED QUADS AND QUOTATIONS

FOR PRICES, FONT SCHEMES AND EXAMPLES OF THEIR USE SEE THE PAGE OPPOSITE

THE H. C. HANSEN TYPE FOUNDRY



HANSEN'S BEVELED QUADS AND QUOTATIONS

PATENT APPLIED FOR

Illustrating a few possibilities. These rules are not soldered, no paper or Plaster Paris being used for justification

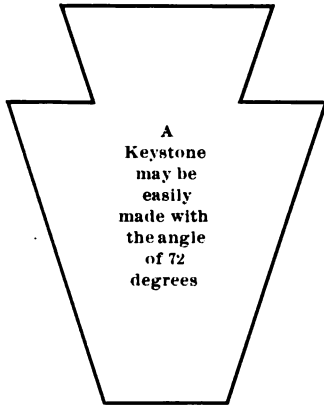

These Quotations and Quads make a form of this description very easy to justify.

Locked on the Point System
Compositors can now smile at angular set-ups by using these labor savers.



Hundreds of different set-ups can now be obtained by using Hansen's Beveled Quotations and Quads

One printer says: "Whenever I get a job with a slanting line or panel I feel like swearing; but these quads are a boon to all printers who have work of this kind, as the time saved on composition and lock-up will very soon pay for fonts of each angle."

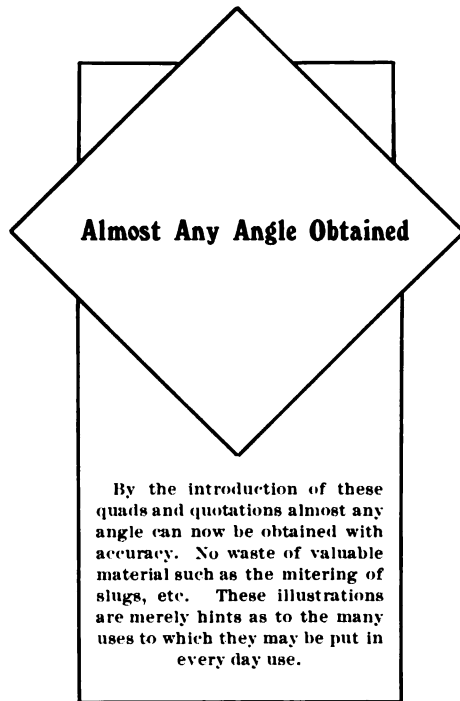

By the introduction of these quads and quotations almost any angle can now be obtained with accuracy. No waste of valuable material such as the mitering of slugs, etc. These illustrations are merely hints as to the many uses to which they may be put in every day use.

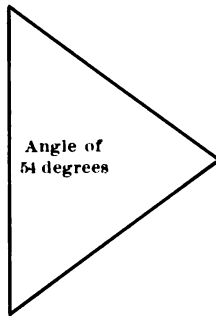
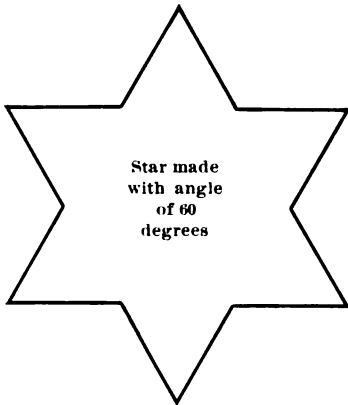

The Beveled Quads and Quotations are cast on five angles, as specified above, and allow a variety of arrangement in angular set-ups never before obtainable without the loss of much valuable time. By using these quotations and quads, lines can be set against an angle and justified as securely as straight matter. They will prove valuable to the printer in many ways, whenever the question of an angle enters into a job. Compositors have always disliked angular jobs, but the difficulty can now be easily overcome.

PRICES

Angle of 45 degrees, per font	\$2.00
" " 64 " " "	1.75
" " 60 " " "	1.50
" " 72 " " "	3.00
" " 78 " " "	3.00

Special separate fonts of angles either of 45, 54 and 60 degrees, containing only a large number of the smaller quads, per font \$3.50 each. Fonts contain characters enough to set eight average angles with sorts.

THE H. C. HANSEN TYPE FOUNDRY



HANSEN'S LABOR-SAVING METAL QUOTATIONS

*Cast in Steel Moulds
on a Type Machine*

The eleven sizes shown below are

2 x 3, 2 x 4, 2 x 5, 2 x 6 } ems
3 x 3, 3 x 4, 3 x 5, 3 x 6 }
4 x 4, 4 x 5, 4 x 6 }

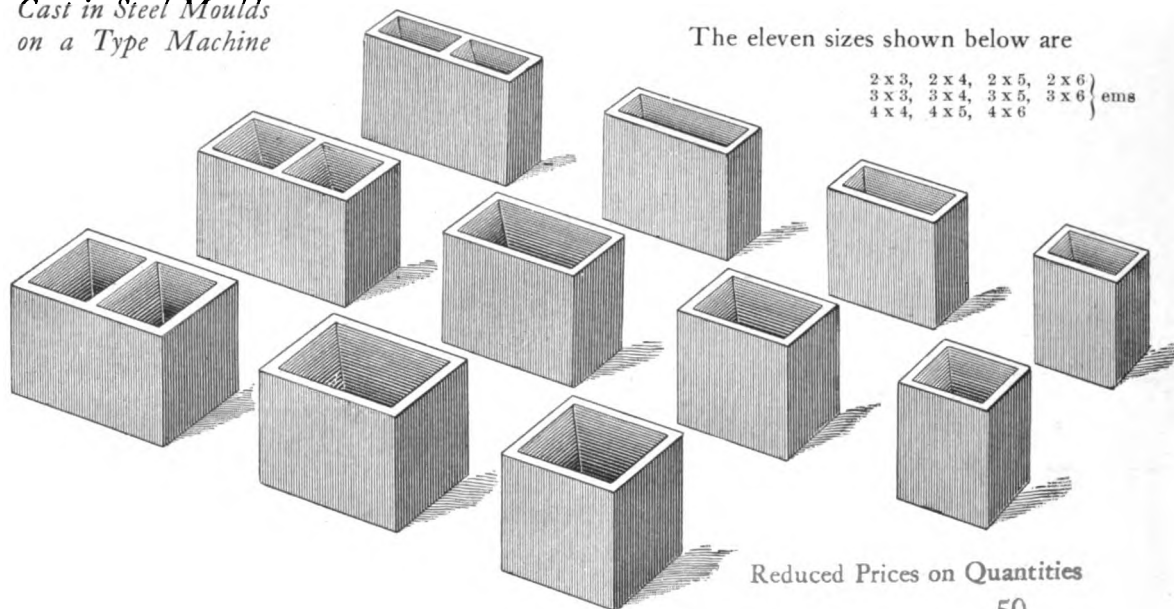

Reduced Prices on Quantities

50

Put up in fonts of 10 pounds or over, or sold individually in any quantity, at ~~25~~ cents per pound. In ordering quotations in fonts it should be specified whether a complete font of the twenty-six sizes are wanted, or the fifteen larger sizes, or the eleven smaller sizes only.

HIGH METAL QUOTATIONS. For Electrotyping, Stereotyping, etc.

Made in five sizes: 3 x 3, 3 x 4, 3 x 5, 3 x 6, 3 x 8 ems, and sold at regular rates

METAL FURNITURE

ACCURATELY FINISHED BY
IMPROVED MACHINERY

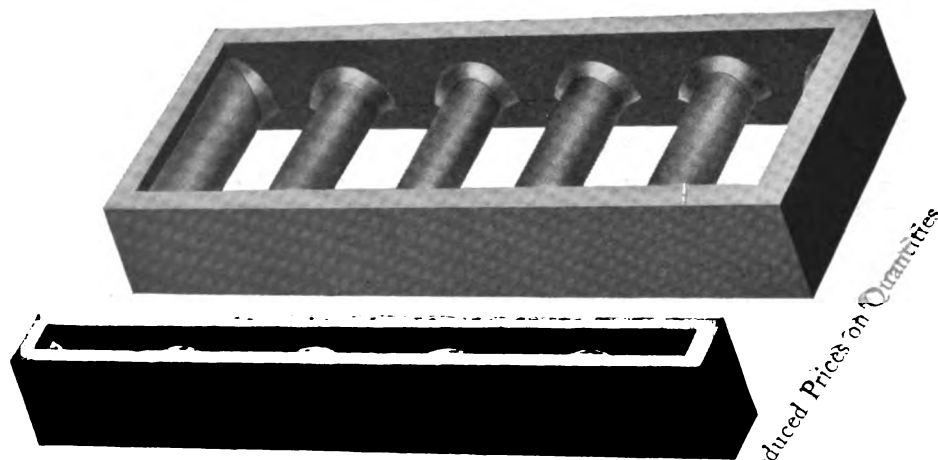

Reduced Prices on Quantities

30

Put up in fonts of 25, 50 and 100 pounds, at ~~25~~ cents per pound

2, 3, 4, 5, 6, 8 and 10 ems in width, and 4, 5, 6, 8, 10, 15, 20 and 25 ems in length. Other lengths to order

THE H. C. HANSEN TYPE FOUNDRY

HANSEN'S NEW LABOR SAVING METAL QUOTATIONS

CAST IN A STEEL MOULD ON
A TYPE MACHINE

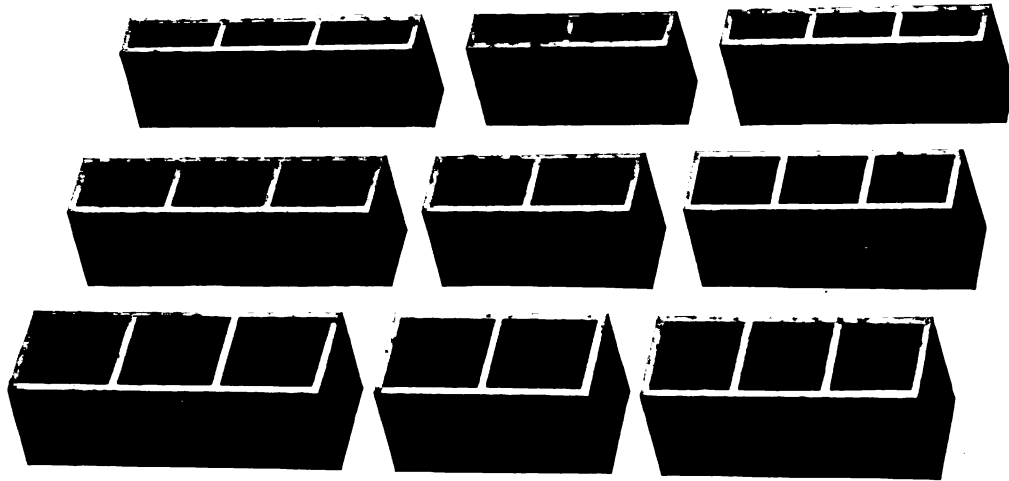

Sizes shown above are

2 x 8, 2 x 10, 2 x 12, 3 x 8, 3 x 10, 3 x 12, 4 x 8, 4 x 10, 4 x 12 ems



Sizes shown above are

2 x 13, 2 x 15, 3 x 13, 3 x 15, 4 x 13, 4 x 15 ems

This assortment of sizes includes the 13 em length, which enables the printer to obtain any odd measurement when used in combination with other sizes, in addition to the advantages of single column measure. Odd sizes such as 12½ and 13½ ems, cast to order. Put up in fonts of 25, 50 and 100 pounds or over, or individually in any quantity, at 25 cents per pound, subject to discount.

30 Reduced Prices on Quantities

THE H. C. HANSEN TYPE FOUNDRY



HANSEN'S NEW LABOR SAVING MAMMOTH METAL FURNITURE

Nine New Sizes Never Made Before

The Metal Furniture that Hansen makes is accurate, carefully made, and is offered in a greater variety of sizes than any other in the world. Put up in 25, 50 and 100 pound fonts at ~~25~~³⁰ cents per pound, or any size will be sold separately in any quantity at the same price, subject to regular discount. The illustrations on this page show four of the new or mammoth sizes, which comprises the largest metal furniture ever cast.

Reduced Prices on Quantities

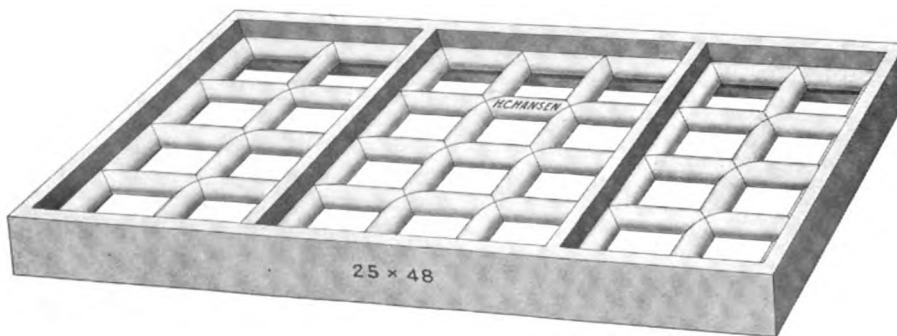
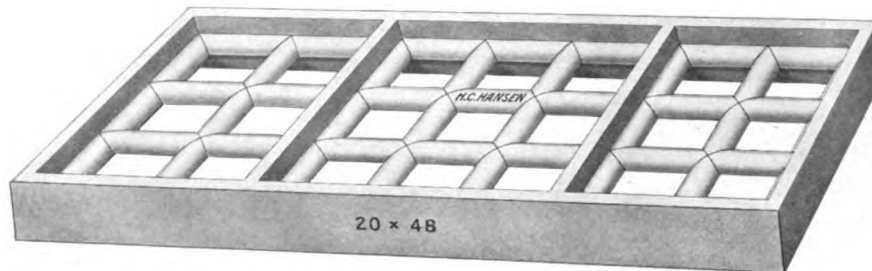
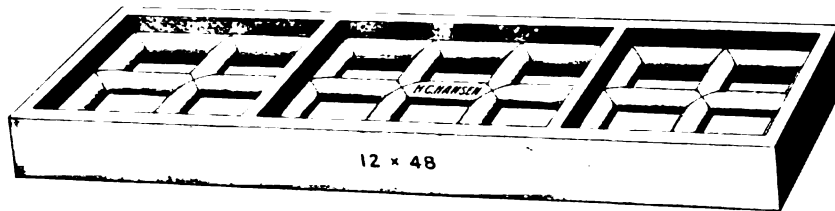
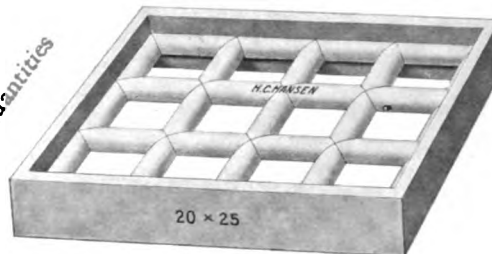

Sizes of Mammoth Metal Furniture

12 x 15	20 x 20
12 x 20	20 x 25
12 x 34	20 x 34
12 x 48	20 x 48
15 x 20	25 x 34
15 x 25	25 x 48

The Only Manufacturers of Metal Furniture in New England

THE H. C. HANSEN TYPE FOUNDRY



LEADS, SLUGS, BRASS LEADS, SPACES, ETC.

HANSEN QUALITY LEADS AND SLUGS STAND THE TEST.

The H. C. Hansen Type Foundry devote an exclusive department to the manufacture of metal leads and slugs, and are the only manufacturers making leads and slugs in New England, having invented special machinery for their accurate production during the past thirty-six years. Almost any spacing material called leads and slugs might seem satisfactory to the printer, but we assure the reader there is a difference, and we take pride in stating that the Hansen quality cannot be surpassed. We have, undoubtedly, sold as much as one hundred thousand pounds of leads and slugs to one printer customer. An interview with any printer will enable us to convince them further of the above facts. We list herein the common sizes, but to interest you we will mention that we have filled orders for thickness measuring twenty-to-pica, which is a remarkable measurement for such an item.

LIST PRICES OF LEADS AND SLUGS PER POUND

Size	Strips, full length	Cut labor saving	Cut to measure	
			2 to 6	1-2 ems 7 ems and over
1 Point	\$0 40	\$0 48	\$0 68	\$0 48
1 1-5 "	30	37	54	37
1 1-2 "	24	30	44	30
1 5-7 "	20	25	40	25
2 " or thicker providing on even points or half points	16	20	35	20

PRICES OF BRASS AND COPPER THIN SPACES

Two ounce package of either half-point copper or one point brass or two ounce package assorted brass and copper, 25 cents a package of any one size.

PRICE PER POUND		PRICE PER POUND	
5 Point	\$2 50	10 Point	\$1 55
5 1-2 "	2 25	11 "	1 45
6 "	2 00	12 to 16 Point	1 40
7 "	1 85	18 to 30 "	1 35
8 "	1 75	36 and larger	1 30
9 "	1 65		

Special prices on 50 pounds and over. High leads and slugs at above prices

One pound may contain either brass or copper or both

LEADS FOR LINING TYPE, ETC.

- FONT A. 1-pt. Brass, containing 7 pieces each 1 to 10 ems by 6-pt. ems; 7 pieces each 11 to 14 ems, 5 pieces each 15 to 19 ems and 6 pieces 20 ems by 12-pt. ems. \$1.00
- FONT B. 2-pt. Metal, containing 12 pieces each 1 to 10 ems by 6-pt. ems and from 11 to 20 ems by 12-pt. ems. 1.00
- FONT C. 3-pt. Metal, containing 8 pieces each 1 to 10 ems by 6-pt. ems and from 11 to 20 ems by 12-pt. ems. 1.00
- Small Labor-Saving Case to hold either 3 fonts of A or one font each of B and C. 0.60



Hansen Assorted Thin Space Case No. 1

HANSEN'S BRASS AND COPPER THIN SPACES

Case No. 1 contains 5 pounds of spaces, viz: 3 pounds of 2-pt. lead and 1 pound each of 1-pt. brass and 1/2-pt. copper, cut up into 6, 8, 10, 12, 18, 24, 36, 48, 60 and 72 points.

Case No. 2 contains 1 pound brass or copper thins or assorted if desired, cut up into 6, 8, 10, 12, 14, 16, 18, 20, 24, 30, 36, 42, 48, 54, 60 and 72 points.

One of the handiest things yet devised for the printing office, saving time and facilitating justification, doing away with the cutting of cardboard and paper and its train of subsequent evils.

- Case No. 1. \$5.00
- Case No. 2. \$1.75

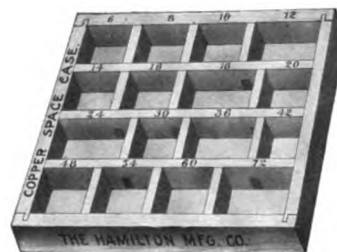

Thin Space Case No. 2

HANDY SPACE AND QUAD CASE

A most convenient little case for spaces and quads, with separate compartments for each size of space and quad, and also thin brass and copper spaces. Eight of these little cases will fit inside a full sized blank case. They can be carried about the office and placed where convenient, without taking up much space. The compartments are proportioned to hold a five pound font of spaces and quads. Size, 7 9-16 x 7 3-8 inches.

List price. \$0.40

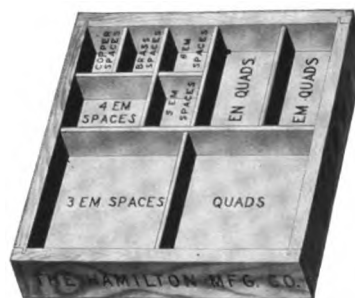



Designs Copyrighted

BERKSHIRE ORNAMENTS

Originated by H. C. Hansen

(Electrotypes)

Order by Number



No. 208. \$1.50



No. 201. \$0.50



No. 79. \$0.75



No. 94. \$0.80



No. 223. \$0.60



No. 215. \$0.50



No. 99. \$1.00



No. 292. \$0.50



No. 315. \$0.35



103. \$0.30



No. 97. \$1.25

THE H. C. HANSEN TYPE FOUNDRY



Designs Copyrighted

BERKSHIRE ORNAMENTS

Originated by H. C. Hansen

(Electrotypes)

Order by Number



No. 18. \$1.25



No. 25. \$0.50



No. 33. \$0.75*



No. 21. \$0.50



No. 47. \$0.60



No. 26. \$0.60



No. 91. \$0.85



No. 221. \$0.85



No. 86. \$0.85



No. 220. \$0.80

*Electrotyped initials shown made only in letters listed

THE H. C. HANSEN TYPE FOUNDRY



Designs Copyrighted

BERKSHIRE ORNAMENTS

Originated by H. C. Hansen

(Electrotypes)

Order by Number



No. 102. \$1.00



No. 19. \$0.60



No. 62. \$1.50



No. 29. \$0.50



No. 40. \$0.50



No. 64. \$0.50

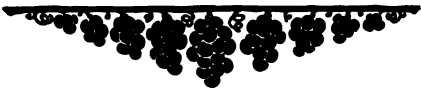

No. 69. \$0.50



No. 78. \$0.80



No. 44. \$0.50



No. 65. \$0.50



No. 42. \$0.50



No. 69. \$0.50



No. 63. \$0.50



No. 60. \$0.50



No. 61. \$0.50

THE H. C. HANSEN TYPE FOUNDRY



Designs Copyrighted

BERKSHIRE ORNAMENTS

Originated by H. C. Hansen

(Electrotypes)

Order by Number

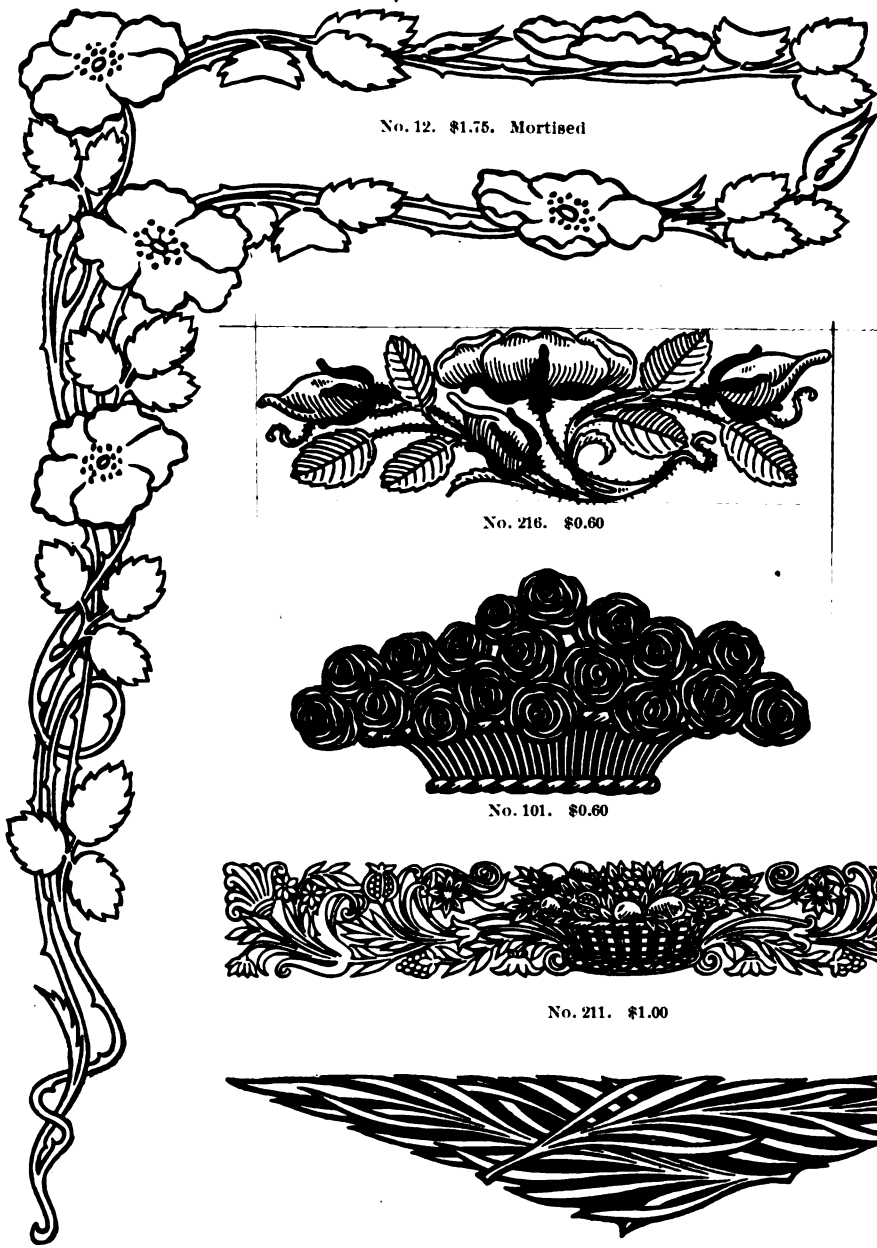

No. 12. \$1.75. Mortised



No. 216. \$0.60



No. 101. \$0.60



No. 211. \$1.00



No. 89. \$0.90



No. 230. \$0.75



No. 83. \$0.30

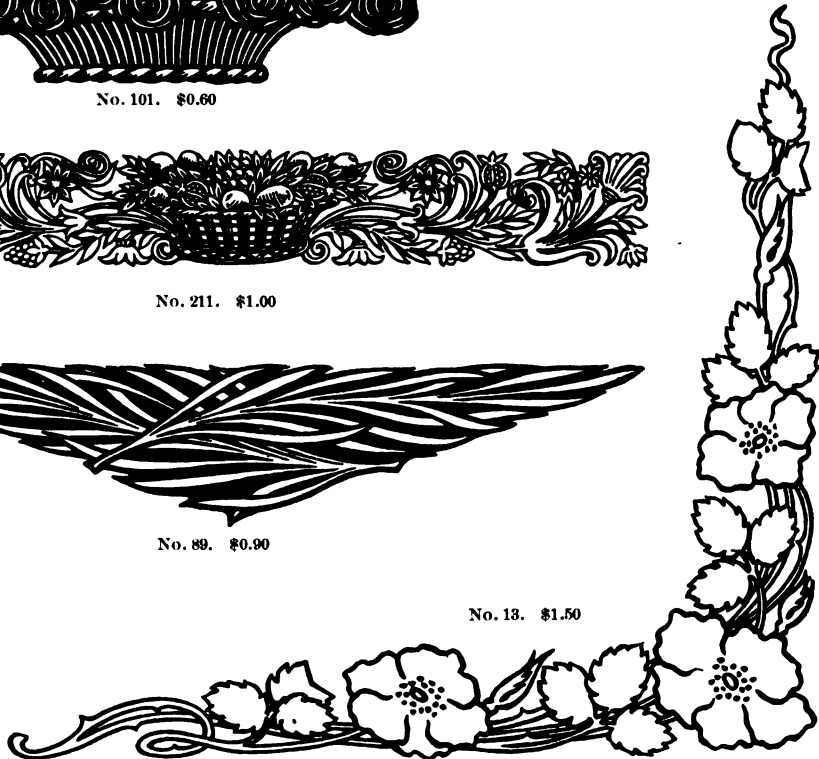

No. 13. \$1.50

THE H. C. HANSEN TYPE FOUNDRY



Designs Copyrighted

BERKSHIRE ORNAMENTS

Originated by H. C. Hansen

(Electrotypes)

Order by Number



No. 208. \$1.50

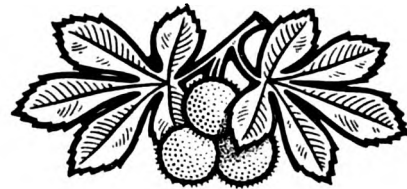

No. 201. \$0.50



No. 79. \$0.75



No. 94. \$0.80



No. 223. \$0.60



No. 215. \$0.50



No. 99. \$1.00



No. 292. \$0.50



No. 315. \$0.35



103. \$0.30

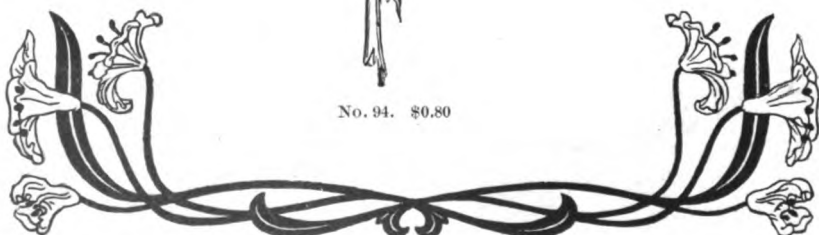

No. 97. \$1.25

THE H. C. HANSEN TYPE FOUNDRY

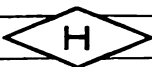

Designs Copyrighted

BERKSHIRE ORNAMENTS

Originated by H. C. Hansen

(Electrotypes)

Order by Number

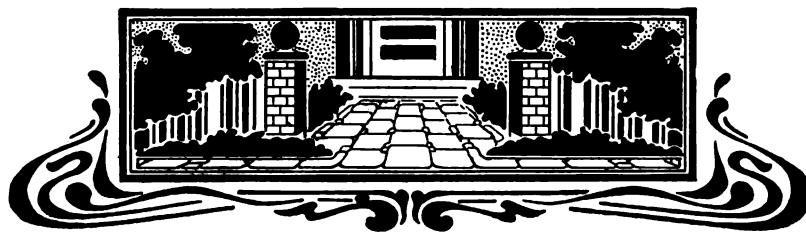

No. 18. \$1.25



No. 25. \$0.50



No. 33. \$0.75*



No. 21. \$0.50



No. 47. \$0.60



No. 26. \$0.60



No. 91. \$0.85



No. 221. \$0.85



No. 86. \$0.85



No. 220. \$0.80

*Electrotyped initials shown made only in letters listed

THE H. C. HANSEN TYPE FOUNDRY



Designs Copyrighted

BERKSHIRE ORNAMENTS

Originated by H. C. Hansen

(Electrotypes)

Order by Number



No. 102. \$1.00



No. 19. \$0.60



No. 62. \$1.50



No. 29. \$0.50



No. 40. \$0.50



No. 64. \$0.50



No. 44. \$0.50

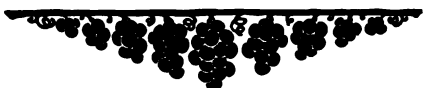

No. 69. \$0.50



No. 76. \$0.80



No. 42. \$0.50



No. 65. \$0.50



No. 63. \$0.50



No. 59. \$0.50



No. 60. \$0.50



No. 61. \$0.50

THE H. C. HANSEN TYPE FOUNDRY



Designs Copyrighted

BERKSHIRE ORNAMENTS

Originated by H. C. Hansen

(Electrotypes)

Order by Number

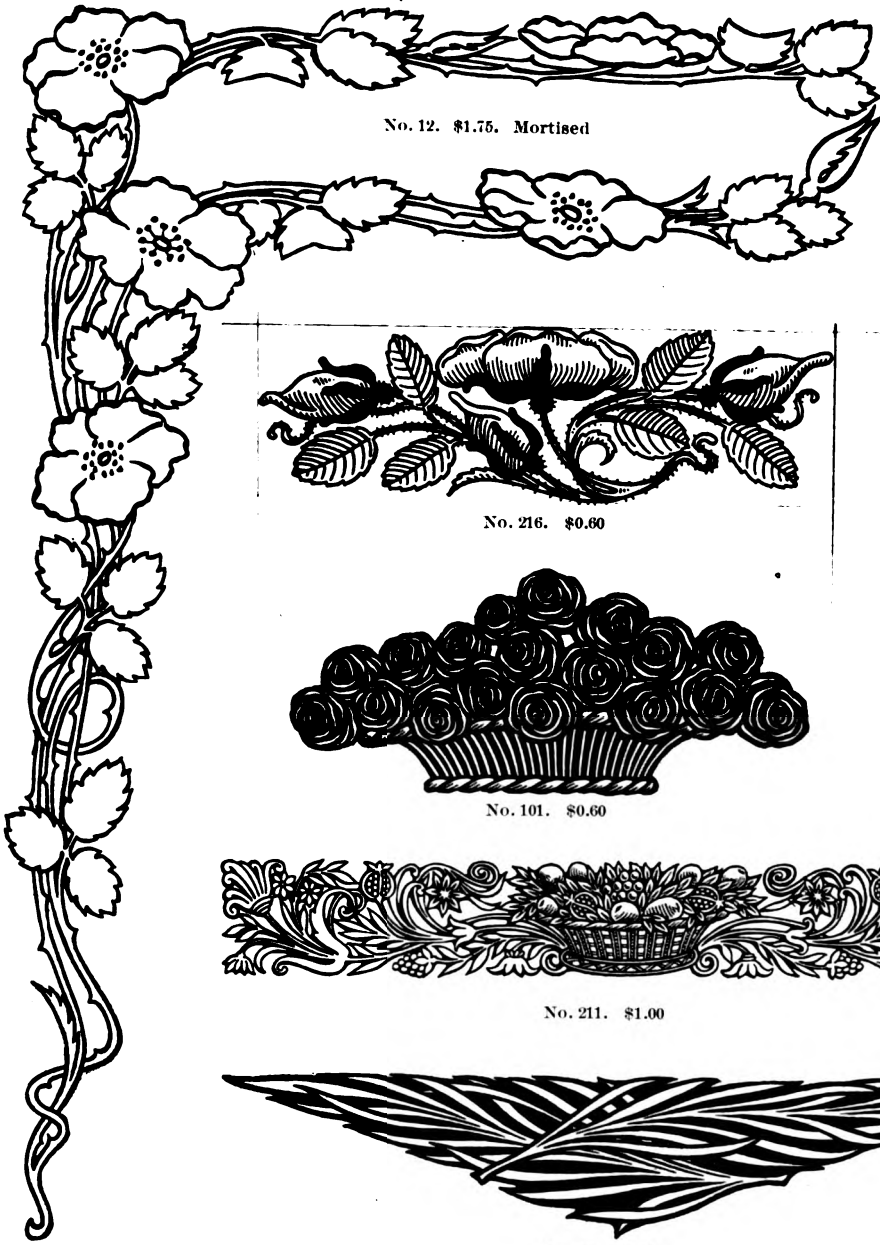

No. 12. \$1.75. Mortised



No. 216. \$0.60



No. 101. \$0.60



No. 211. \$1.00

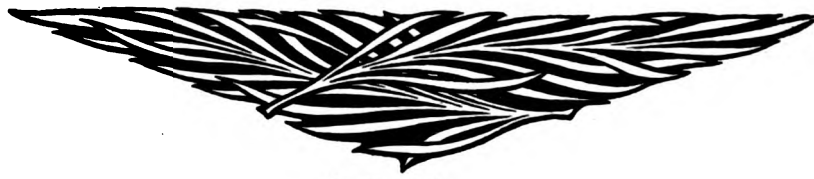

No. 89. \$0.90



No. 230. \$0.75



No. 83. \$0.30

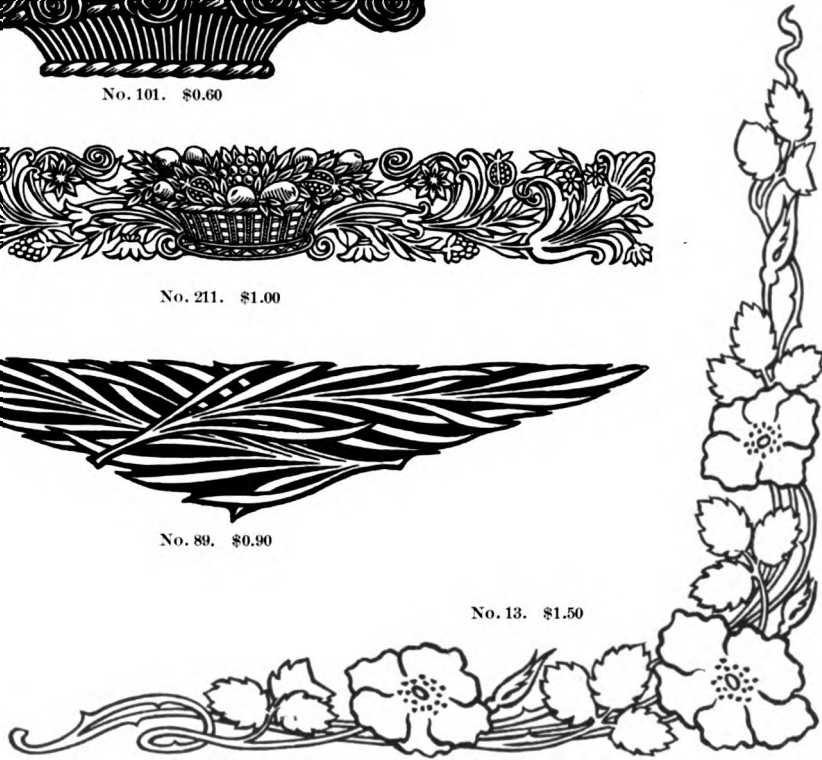

No. 13. \$1.50

THE H. C. HANSEN TYPE FOUNDRY



Designs Copyrighted

BERKSHIRE ORNAMENTS

Originated by H. C. Hansen

(Electrotypes)

Order by Number

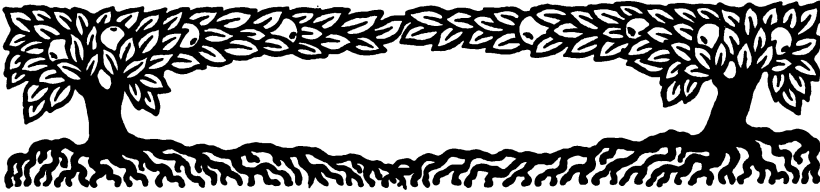

No. 88. \$1.50. Mortised



No. 22. \$0.60



No. 55. \$0.75



No. 205. \$0.80



No. 70. \$0.75



No. 39. \$0.60



No. 23. \$0.75. Mortised

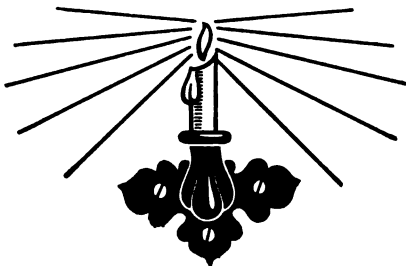

No. 51. \$0.60



No. 82. \$0.75



No. 53. \$0.75



No. 78. \$0.60



No. 81. \$0.75

THE H. C. HANSEN TYPE FOUNDRY



Designs Copyrighted

BERKSHIRE ORNAMENTS

Originated by H. C. Hansen

(Electrotypes)

Order by Number



No. 10. \$1.25 This is a companion cut to design No. 7, shown on page 270. It should then be used in the lower right hand corner



No. 309. \$0.30



No. 35. \$0.25



No. 36. \$0.25



No. 49. \$0.75



No. 500. \$0.50



No. 202. \$0.50



No. 282. \$0.35



No. 75. \$0.60



No. 259. \$0.35



No. 265. \$1.50 Mortised

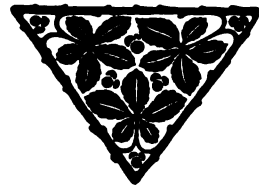

No. 258. \$0.35



No. 240. \$0.60



No. 248. \$0.60

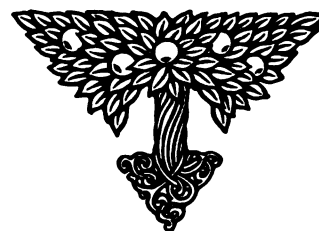

No. 249. \$0.60

THE H. C. HANSEN TYPE FOUNDRY



Designs Copyrighted

BERKSHIRE ORNAMENTS

Originated by H. C. Hansen

(Electrotypes)

Order by Number



No. 11. \$0.90



No. 222. \$0.75



No. 1. \$0.90



No. 320. \$0.25



No. 318. \$0.30

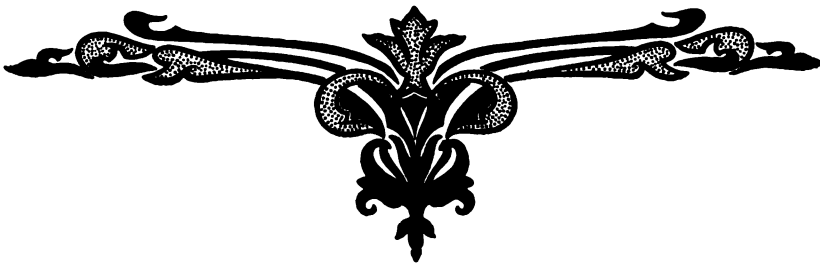

No. 2. \$0.90



No. 304. \$0.45



No. 3. \$0.90



No. 307. \$0.35



No. 288. \$0.25



No. 92. \$1.00



No. 214. \$0.50

THE H. C. HANSEN TYPE FOUNDRY



Designs Copyrighted

BERKSHIRE ORNAMENTS

Originated by H. C. Hansen

(Electrotypes)

Order by Number



No. 217. \$1.00



No. 310. \$0.50



No. 289. \$0.40



No. 218. \$1.00



No. 289. \$0.60



No. 200. \$0.90



No. 20. \$1.00 Mortised center, \$0.25 extra



No. 30. \$0.75



No. 31. \$0.75



No. 229. \$0.40



No. 206. \$0.35

THE H. C. HANSEN TYPE FOUNDRY



Designs Copyrighted

BERKSHIRE ORNAMENTS

Originated by H. C. Hansen

(Electrotypes)

Order by Number

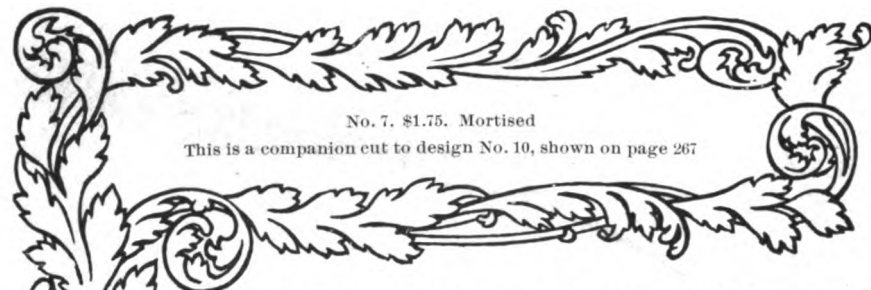

No. 7. \$1.75. Mortised

This is a companion cut to design No. 10, shown on page 267



No. 241. \$0.60



No. 246. \$0.60



No. 250. \$0.80



No. 242. \$0.35



No. 251. \$0.40



No. 257. \$0.35



No. 254. \$0.40



No. 245. \$0.60



No. 243. \$0.35



No. 253. \$0.60



No. 261. \$0.35



No. 264. \$0.35



No. 244. \$0.35



No. 98. \$0.50



No. 256. \$0.35



No. 247. \$0.45



No. 252. \$0.40



No. 255. \$0.25



No. 260. \$0.25



No. 263. \$0.20

THE H. C. HANSEN TYPE FOUNDRY



Designs Copyrighted

BERKSHIRE ORNAMENTS

Originated by H. C. Hansen

(Electrotypes)

Order by Number



No. 293. \$0.60



No. 291. \$0.50



No. 24. \$0.75



No. 96. \$0.80



No. 54. \$0.60



No. 98. \$0.80



No. 56. \$0.60



No. 226. \$0.60



No. 209. \$0.80



No. 225. \$0.60



No. 212. \$0.80

THE H. C. HANSEN TYPE FOUNDRY



Designs Copyrighted

BERKSHIRE ORNAMENTS

Originated by H. C. Hansen

(Electrotypes)

Order by Number

No. 4. \$0.90



No. 72. \$1.25



No. 87. \$0.90



No. 43. \$0.40



No. 90. \$1.35

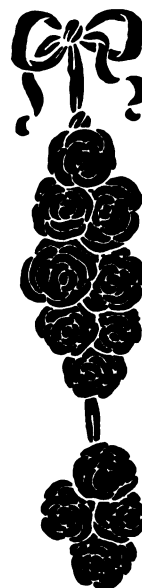

No. 45. \$0.60



No. 100. \$0.30



No. 46. \$0.50



No. 74. \$0.75



No. 80. \$0.75

THE H. C. HANSEN TYPE FOUNDRY



Designs Copyrighted

BERKSHIRE ORNAMENTS

Originated by H. C. Hansen

(Electrotypes)

Order by Number



No. 84. \$1.25. Mortised



No. 58. \$0.85



No. 52. \$0.85



No. 85. \$1.00

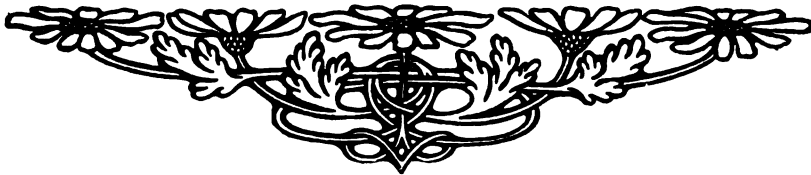

No. 57. \$0.85



No. 210 \$0.75



No. 207. \$0.50

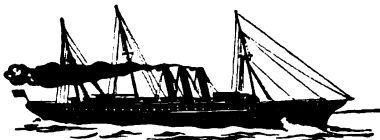

No. 295. \$0.60



No. 296. \$0.60



No. 224. \$0.50

THE H. C. HANSEN TYPE FOUNDRY

Designs Copyrighted

BERKSHIRE ORNAMENTS

Originated by H. C. Hansen

(Electrotypes)

Order by Number



No. 334. \$0.75



No. 288. \$0.75



No. 335. \$0.75



No. 333. \$0.35



No. 316. \$0.45



No. 308. \$0.35



No. 306. \$0.35



No. 273. \$0.50



No. 301. \$0.35



No. 281. \$0.75

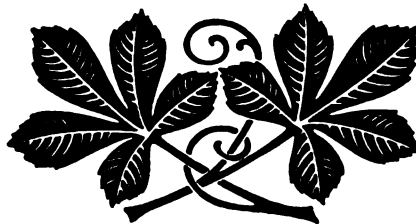

No. 271. \$0.60



No. 282. \$0.75



No. 336. \$0.35

No. 337. \$0.25

No. 338. \$0.35



No. 284. \$0.75



No. 280. \$0.50



No. 269. \$0.50



No. 294. \$0.50



No. 270. \$0.50



No. 272. \$0.50

THE H. C. HANSEN TYPE FOUNDRY



Designs Copyrighted

BERKSHIRE ORNAMENTS

Originated by H. C. Hansen

(Electrotypes)

Order by Number

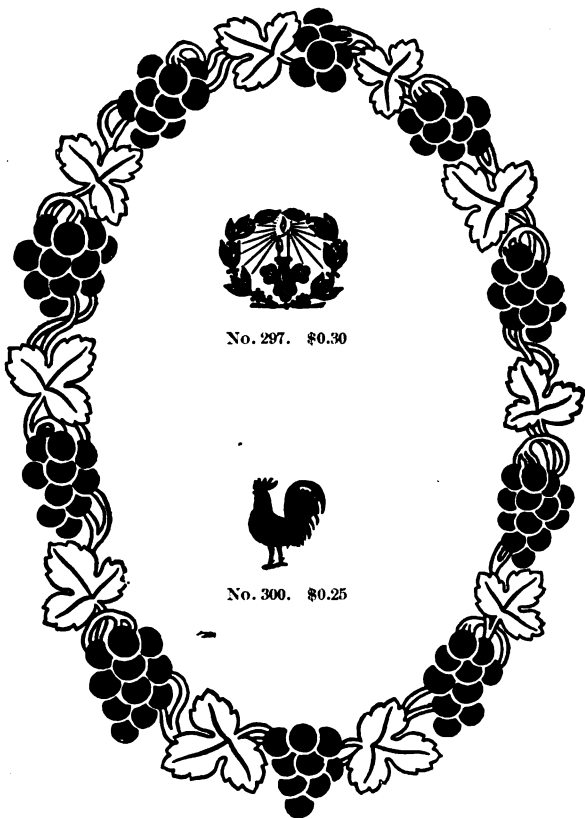

No. 297. \$0.30



No. 300. \$0.25



No. 27. \$0.75

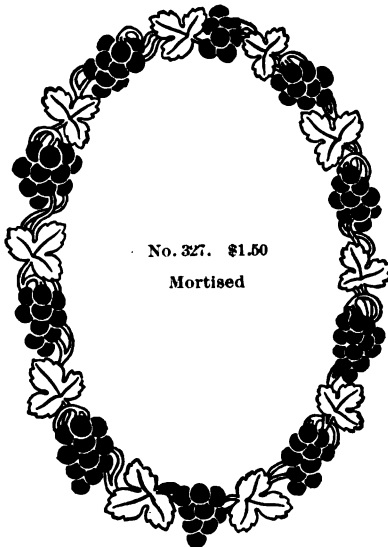

No. 327. \$1.50
Mortised

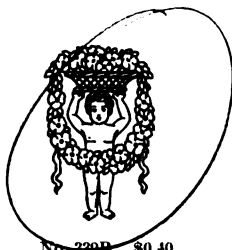

No. 329B. \$0.40



No. 340B. \$0.30



No. 302. \$0.35

No. 332. \$2.00. Mortised



No. 274. \$0.90



No. 283. \$0.75



No. 313. \$0.45



No. 317. \$0.50



No. 314. \$0.35



No. 319. \$0.40



No. 305. \$0.45

THE H. C. HANSEN TYPE FOUNDRY



Designs Copyrighted

BERKSHIRE ORNAMENTS

Originated by H. C. Hansen

(Electrotypes)

Order by Number

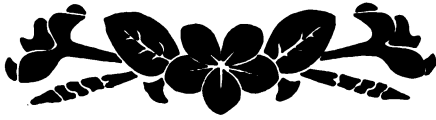

No. 126. \$0.50

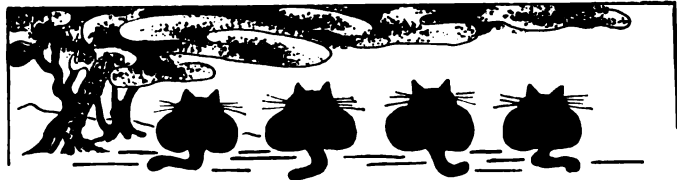

No. 348. \$0.80



No. 349. \$0.60



No. 350. \$0.45



No. 347. \$0.75



No. 346. \$0.80

No. 138. \$1.50. Mortised



No. 136. \$0.75



No. 351. \$0.80



No. 135. \$0.50

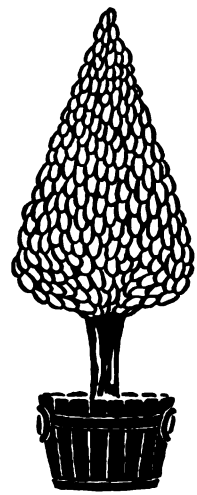

No. 128. \$0.75

THE H. C. HANSEN TYPE FOUNDRY

BERKSHIRE ORNAMENTS

ISSUED SINCE THE COMPLETION OF OUR CATALOG

Originated by
The H. C. Hansen
Type Foundry



No. 509 \$1.00



No. 517 \$0.50



No. 524 \$0.30

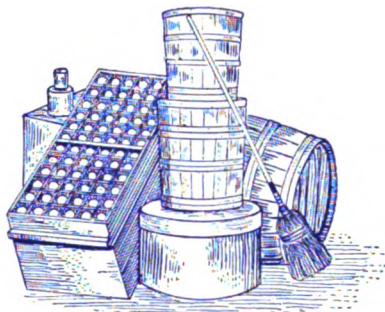

No. 504 \$0.75

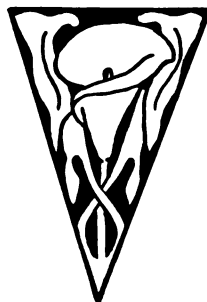

No. 520 \$0.40



No. 505 \$0.75

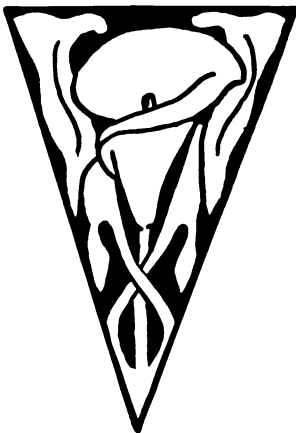

No. 521 \$0.75

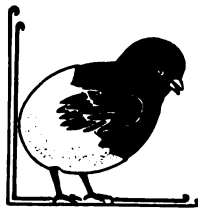

No. 503 \$0.40



No. 525 \$0.75

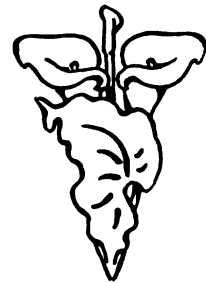

No. 523 \$0.40



No. 513 \$0.50



No. 519 \$0.75



No. 512 \$0.60



No. 515 \$0.60

THE H. C. HANSEN TYPE FOUNDRY
190-192 Congress St., Boston
43 Centre St., New York

Please insert this sheet in our 1909 catalog.

F802-2-09-12M

Berkshire Ornaments *The H. C. Hansen Type Foundry*
 Boston, Mass. New York City

New and Original Designs

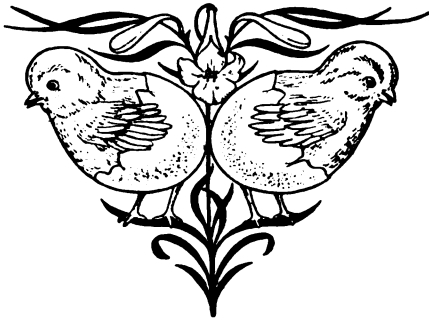

No. 506 \$0.75



No. 518 \$0.50

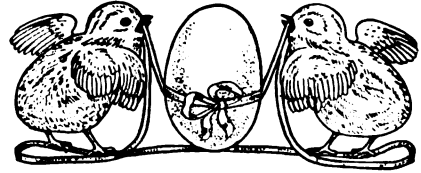

No. 516 \$0.60



No. 527 \$0.50

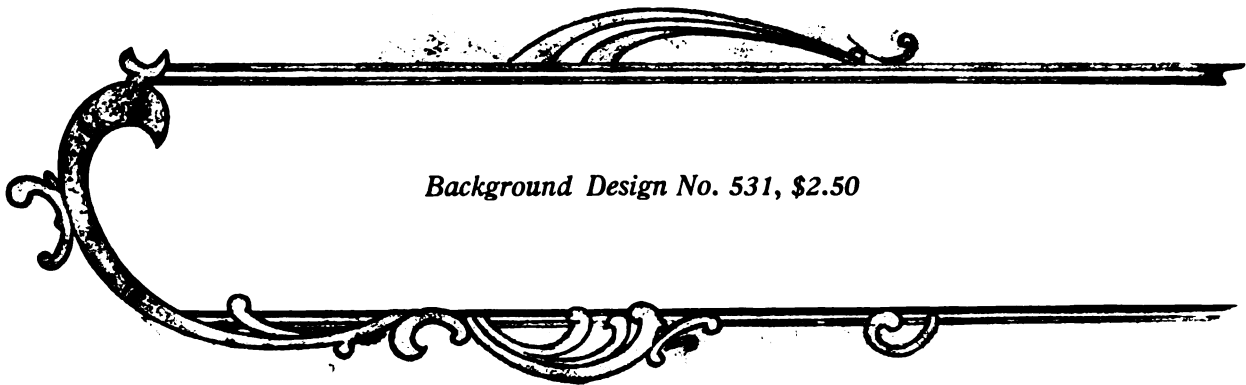

Background Design No. 531, \$2.50



No. 511 \$0.40



No. 529 \$0.35

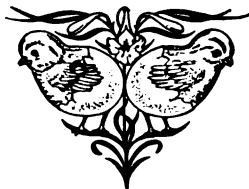

No. 514 \$0.40

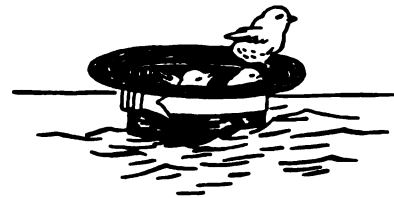

No. 525 \$0.50

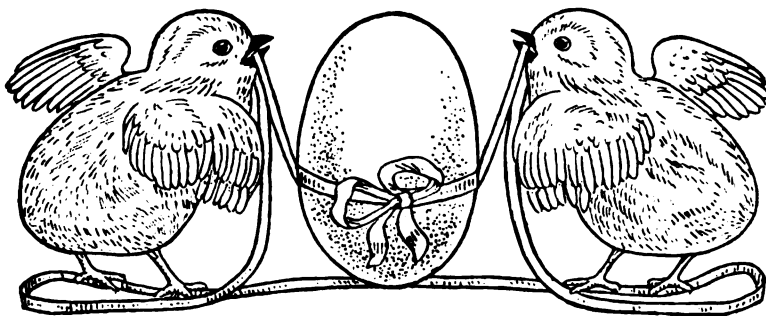

No. 508 \$1.00



No. 507 \$0.75



Designs Copyrighted

BERKSHIRE ORNAMENTS

Originated by H. C. Hansen

(Electrotypes)

Order by Number



No. 143. \$0.75

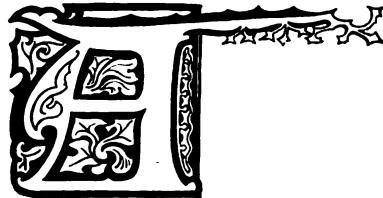

No. 151. \$0.60. Mortised.



No. 144. \$0.75



No. 141. \$0.40

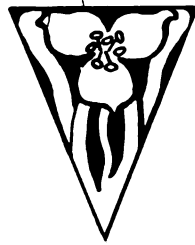

No. 140. \$0.35



No. 142. \$0.40

Designs Copyrighted

SANTA CLAUS CUTS

Originated by H. C. Hansen



No. 379. \$1.00



No. 377. \$0.75

No. 381
Same cut, size 2 1/4 x 4 1/4 in., \$1.50



No. 378. \$0.75

No. 382
Same cut, size 2 x 4 in., \$1.50



No. 380. \$1.00



No. 375. \$0.60

No. 376. Same cut, size 3/4 x 4 1/4 in. \$1.00

THE H. C. HANSEN TYPE FOUNDRY



Designs Copyrighted

SYMPHONY ORNAMENTS

Originated by H. C. Hansen

(Electrotypes)

Order by Number



No. 32. \$1.00 Mortised



No. 28. \$0.60



No. 41. \$0.75



No. 48. \$1.00 Mortised



No. 95. \$1.00



No. 34. \$0.25



No. 50. \$0.25

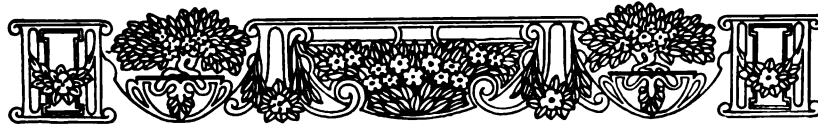

No. 6. \$1.25

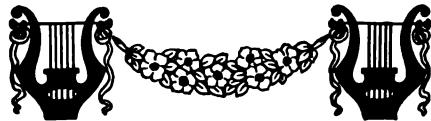

No. 66. \$0.60



No. 77. \$0.25



No. 68. \$0.60



No. 137. \$0.75

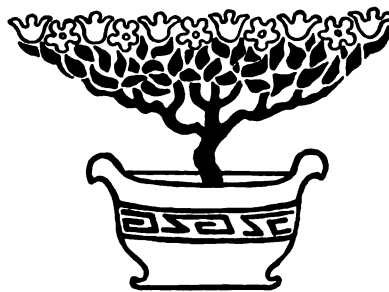

No. 130. \$0.60

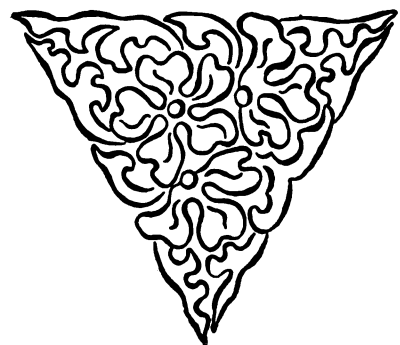

No. 127. \$0.60

THE H. C. HANSEN TYPE FOUNDRY



Designs Copyrighted

SYMPHONY ORNAMENTS

Originated by H. C. Hansen

(Electrotypes)

Order by Number



No. 290. \$1.00

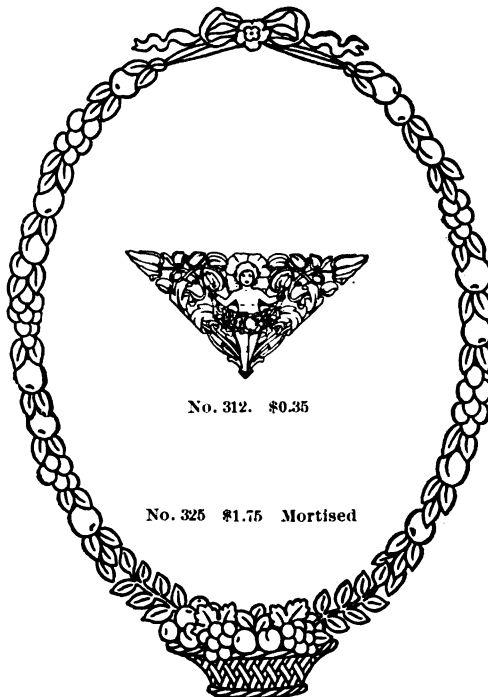

No. 312. \$0.35

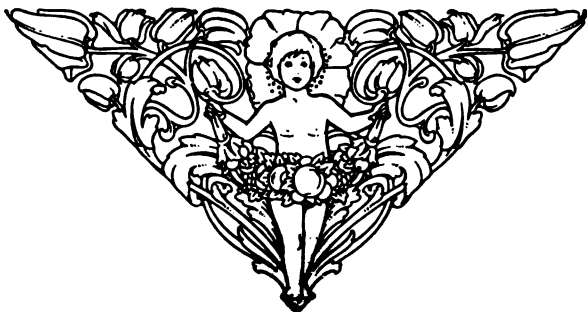

No. 287. \$1.00

No. 325 \$1.75 Mortised



No. 286. \$0.75



No. 339. \$0.25



No. 17. \$1.00



No. 330. \$1.50
Mortised



No. 277. \$1.00



No. 278. \$0.90

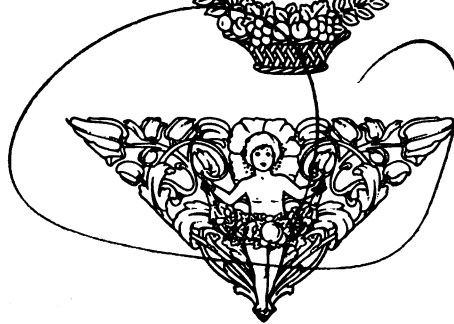

No. 311. \$0.75

THE H. C. HANSEN TYPE FOUNDRY



Designs Copyrighted

SYMPHONY ORNAMENTS

Originated by H. C. Hansen

(Electrotypes)

Order by Number

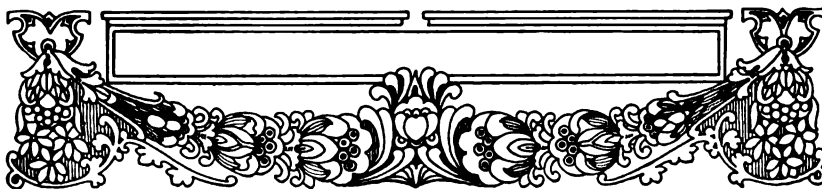

No. 233. \$1.50. Mortised



No. 14. \$1.75



No. 9. \$1.25



No. 5. \$1.75



No. 15. \$1.25



No. 16. \$1.25



No. 67. \$0.45

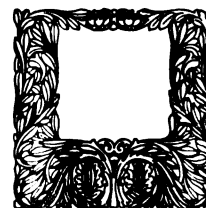

No. 38. \$0.45 Mortised



No. 232. \$0.75

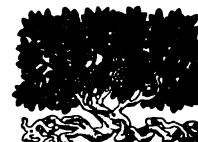

No. 37. \$0.40



No. 73. \$0.50. Mortised

THE H. C. HANSEN TYPE FOUNDRY



Designs Copyrighted

SYMPHONY ORNAMENTS

Originated by H. C. Hansen

(Electrotypes)

Order by Number

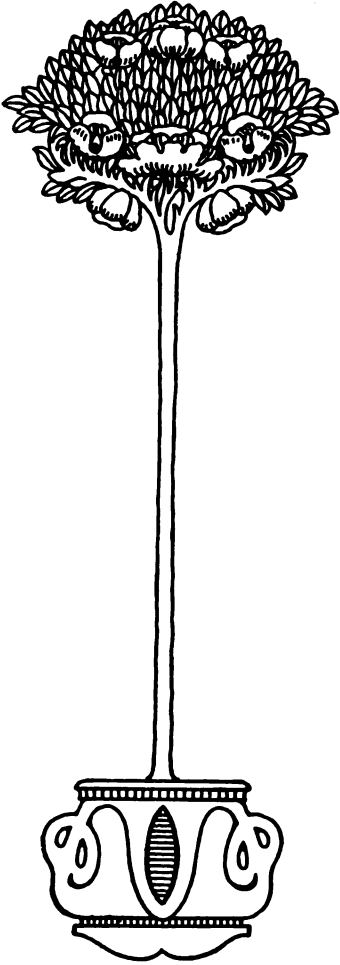

No. 340. \$1.25

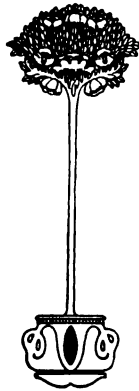

No. 342. \$0.75



No. 344. \$1.00

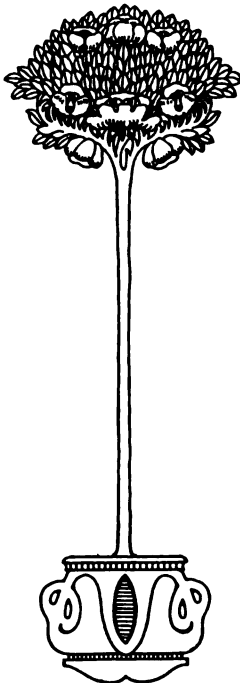

No. 341. \$1.00



No. 343. \$0.60

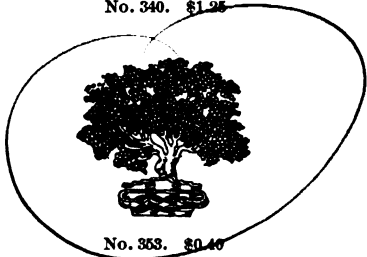

No. 353. \$0.40



No. 354. \$0.50

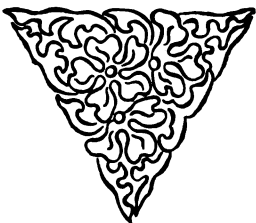

No. 125. \$0.35



No. 129. \$0.40

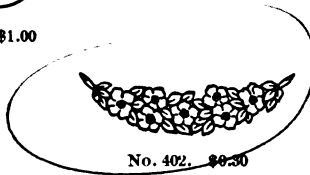

No. 402. \$0.30



No. 400. \$0.20

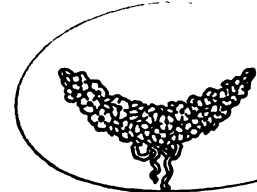

No. 401. \$0.30

THE H. C. HANSEN TYPE FOUNDRY



Designs Copyrighted

POST CARD HEADINGS

Originated by H. C. Hansen

(Electrotypes)

Order by Number



No. 275. \$1.75



No. 268. Cut only, \$1.25

THE H. C. HANSEN TYPE FOUNDRY

190-192 Congress Street,

Boston, Mass.



No. 267. \$1.00

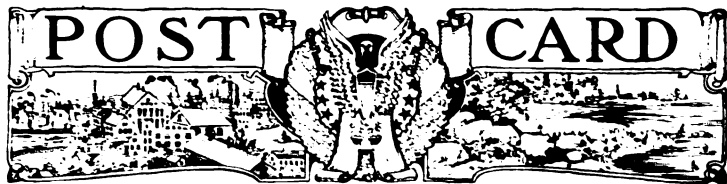

No. 266. \$1.25

THE H. C. HANSEN TYPE FOUNDRY

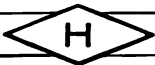

Designs Copyrighted

HOLLY ORNAMENTS

Originated by H. C. Hansen

(Electrotypes)

Order by Number



No. 204. \$0.75



No. 323
One color, \$1.50
Two colors, \$2.75
Mortised

No. 331
Same cut, size 3x3 1/4 in
One color, \$1.75
Two colors, \$3.25
Mortised



No. 227. \$0.75



No. 321. One color, \$1.60
Two colors, \$3.00. Mortised

No. 322. Same cut, size 4 ins
One color, \$2.00
Two colors, \$3.75. Mortised

No. 324. Same cut, size 2 ins
One color, \$1.00
Two colors, \$1.75. Mortised

No. 326. Same cut, size 1 1/2 ins
One color, \$0.75
Two colors, \$1.25. Mortised



No. 328
One color, \$0.75 Two colors, \$1.25
Mortised

No. 329. Same cut, size 2 1/2 x 2 1/2 inches
One color, \$1.00 Two colors, \$1.75
Mortised



No. 219. \$0.60



No. 203. \$0.60



No. 228. \$1.00
Mortised

THE H. C. HANSEN TYPE FOUNDRY



MISCELLANEOUS SOCIETY EMBLEMS

(Electrotypes)

Order by Number



No. 101. \$0.40
Two colors, \$0.75



No. 64. \$0.30



No. 135. \$0.30



No. 320. \$0.40



No. 111. \$0.35



No. 286. \$0.30



No. 239. \$0.30



No. 211E. \$0.30



No. 511. \$0.40



No. 133. \$0.35

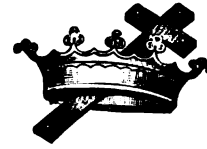

No. 74. \$0.35



No. 999. \$0.30



No. 266. \$0.40



No. 998. \$0.40



No. 100. \$0.50



No. 997. \$0.40



No. 367. \$0.40



No. 309. \$0.35



No. 296C. \$0.40



No. 375. \$0.75

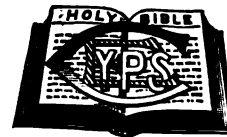

No. 128. \$0.50



No. 105. \$0.25



No. 233. \$0.40

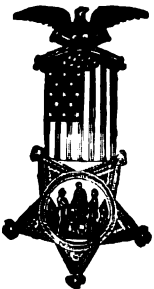

No. 777. \$0.40
Four colors, \$1.50



No. 868. \$0.40
Four colors, \$1.50



No. 991. \$0.50



No. 433. \$0.40



No. 88. \$0.20



No. 627. \$0.30



No. 66. \$0.35



No. 55. \$0.50

THE H. C. HANSEN TYPE FOUNDRY

ILLUSTRATED AND DESCRIPTIVE
CATALOG, INCLUDING PRICE LIST
OF PRINTING MACHINERY
MATERIALS and SUPPLIES

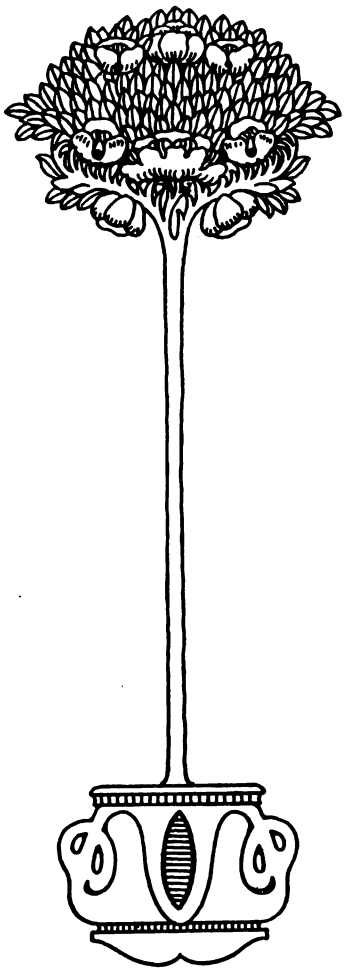

*Further Prices and Discounts
on application*

The H. C. HANSEN
TYPE FOUNDRY
BOSTON, MASSACHUSETTS
BRANCH, NEW YORK CITY

REPRESENTED IN
ST. PAUL, MINN. GRAND RAPIDS, MICH.
CHICAGO, ILL. PHILADELPHIA, PA.
ATLANTA, GA.



BRASS RULE CASES

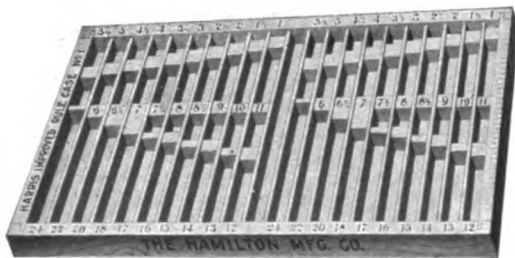

HARRIS RULE CASE No. 1
Price, \$1.25

This case holds two complete small fonts of labor-saving rule, each weighing 8 pounds or 16 pounds in all. Each half of this case holds 18 pieces each length from 1 to 8½ ems (varying by ems), 18 pieces each from 9 to 18 ems (varying by ems), and 9 pieces each 19, 20, 21, 22, 24, 26, and 28 ems, besides boxes for right and left miters. Size, 7¾ x 15½ inches. Weight, 19 ounces.

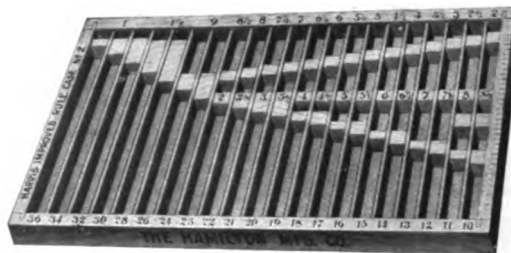

HARRIS RULE CASE No. 2
Price, \$1.00

This case holds one complete font of 16 pounds weight. It has compartments for 36 pieces each from 1 to 9 ems long (varying by ems), 18 pieces each from 10 to 24 ems (varying by ems), and 18 pieces each of 26, 28, 30, 32, 34, 36 ems long, besides boxes for right and left miters. A large proportion of small lengths. Size, 7¾ x 15½ inches. Weight, 19 ounces.

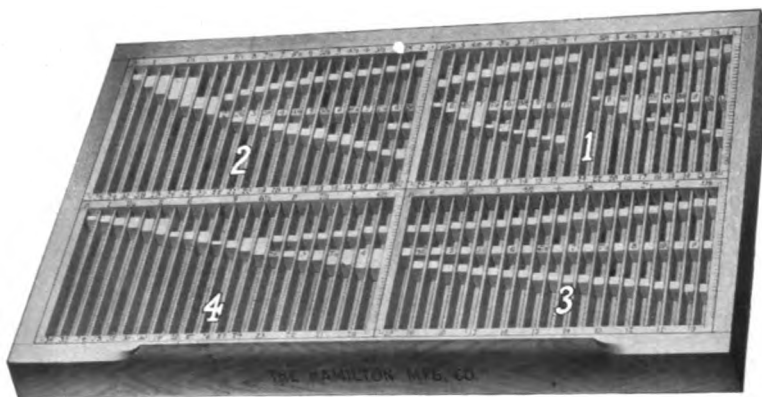

FOUR HARRIS RULE CASES IN FULL SIZE BLANK CASE
Price, \$4.65, including the Blank Case

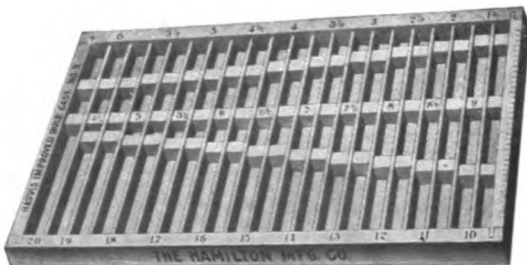

HARRIS RULE CASE No. 3
Price, \$0.75



HARRIS RULE CASE No. 4
Price, \$1.00

These two cases are designed to be used together to hold a font of rule weighing 32 pounds or less. Case No. 3 has compartments for all short lengths up to and including the 20 em length. Case No. 4 has compartments for all of the short lengths and also all long lengths up to and including the 36 em length. Together these cases have compartments for 72 pieces each from 1 to 9 ems long (varying by ems), 36 pieces each from 10 to 24 ems long (varying by ems), and 18 pieces each from 25 to 36 ems long, (varying by ems), besides boxes for right and left miters. Size, 7¾ x 15½ inches.

THE H. C. HANSEN TYPE FOUNDRY



BRASS RULE CASES

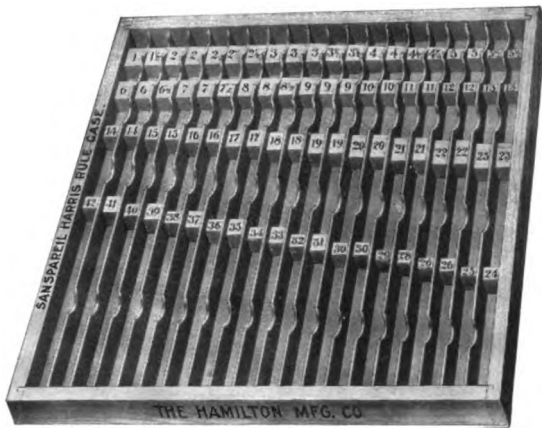

SANSPAREIL HARRIS RULE CASE

Price, \$1.50

The size of this case $14\frac{1}{2} \times 15\frac{1}{2}$ inches—2 cases fit into one standard blank case. The walls and partitions are a trifle over type high, so the rules are at all times protected.

Each case is complete with all sizes from 1 to $9\frac{1}{2}$ ems, varying by nonpareils, and from 10 to 42, varying by picas, with an extra allowance for small sizes; also an additional row for miters (second row of small sizes) which, when no miters are carried, can be used for overflow on small sizes, of which there is always a large stock.

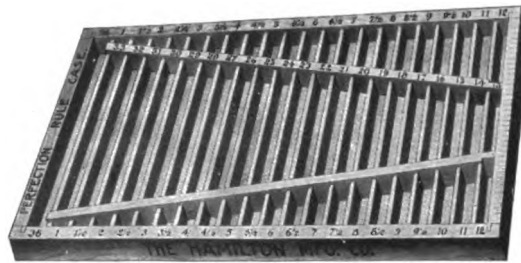

PERFECTION RULE CASE

Price, \$0.90

This case has two compartments for all lengths from 1 to 12 and one compartment for lengths from 13 to 36 ems. The variations are by ems from 1 to 10, and by ems from 10 to 36. Size, $7\frac{1}{2} \times 15\frac{1}{2}$ inches. Four of these cases fit in full size blank case.

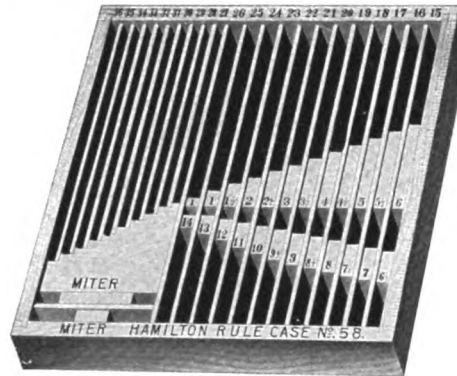

HAMILTON RULE CASE No. 58

Price, \$0.75

This case takes a 5 pound font of standard rule on 2 point body. Separate compartments for every length from 1 to 36 picas long, inclusive, with separate compartments for miters. All compartments are narrow, so that rules will always remain standing on edge. A line gauge for determining lengths is printed on edge of each case. Size, $8\frac{1}{2} \times 9\frac{1}{2}$ inches.

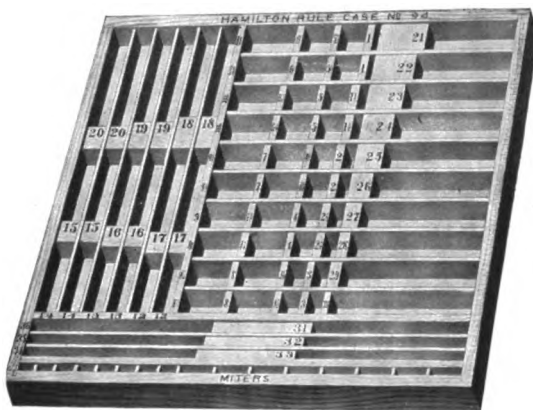

HAMILTON RULE CASE No. 94

Price, \$1.40

This case takes a 25 pound font of standard rule on 2 point body. Separate compartments are provided for every length from 1 to 36 picas long, inclusive, with separate compartments for two sizes of miters. Where there are a large number of pieces in the shorter lengths, the compartments are doubled, two for each length, so as to maintain narrowness of compartments in order to keep the rules standing. A line gauge for determining lengths is printed on the edge of each case. Size, $15\frac{1}{2} \times 12\frac{1}{2}$ inches.

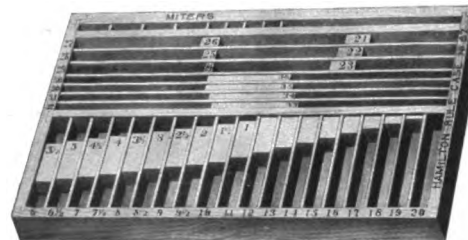

HAMILTON RULE CASE No. 67

Price, \$1.25

This case takes a 10 pound font of standard rule on 2 point body. Separate compartments are provided for every length from 1 to 36 picas long, inclusive, with separate compartments for miters. All compartments are narrow, so that rules will always stand on edge. A line gauge for determining lengths is printed on edge of case. Size, $7\frac{1}{2} \times 14\frac{1}{2}$ inches.

THE H. C. HANSEN TYPE FOUNDRY



NEW DEPARTURE CASES

FULL SIZE

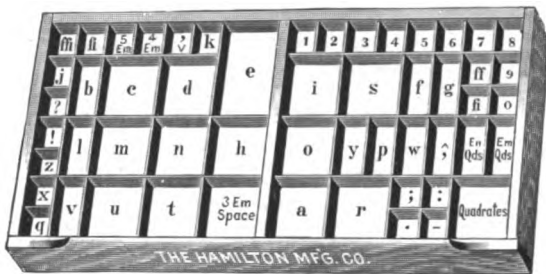

News Cases. Price, per Pair: Plain, \$1.60; With clasps, \$1.75



Two Rivers Cap Case
Plain, \$0.90 With clasps, \$1.00

California Job Case
Plain, \$0.90 With clasps, \$1.00

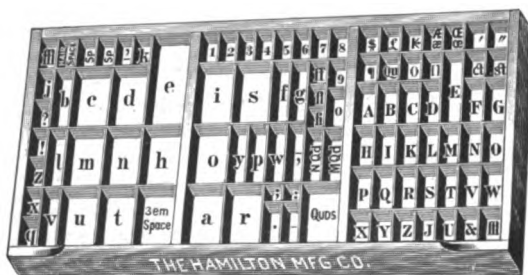

Wheeler Job Case
Plain, \$0.90 With clasps, \$1.00

Italic Job Case
Plain, \$0.90 With clasps, \$1.00



Combination Job Case
Plain, \$1.20 With clasps, \$1.35

Yankee Job Case
Plain, \$1.00 With clasps, \$1.15

THE H. C. HANSEN TYPE FOUNDRY



NEW DEPARTURE CASES

FULL SIZE



Dearing Job Case
Plain, \$1.00 With clasps, \$1.15

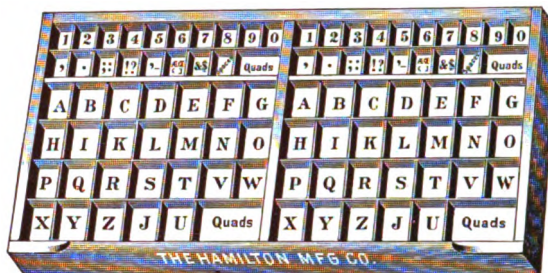

Wells Job Case
Plain, \$1.00 With clasps, \$1.15



Improved Job Case
Plain, \$1.20 With clasps, \$1.40



Spaceless Job Case
Plain, \$1.00 With clasps, \$1.15



Triple Case
Plain, \$0.90 With clasps, \$1.00

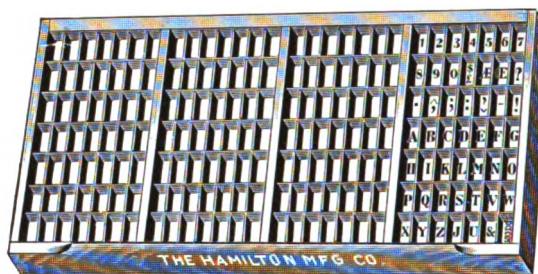

Quadruple Case
Plain, \$1.20 With clasps, \$1.35

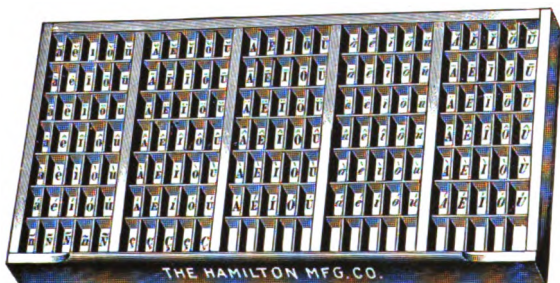

Dearing Accent Case
Plain, \$1.50 With clasps, \$1.80

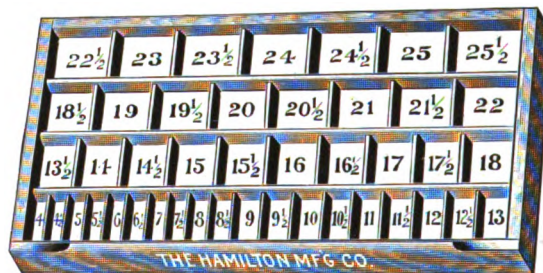

Two Rivers Lead and Slug Case
Plain, \$1.75

THE H. C. HANSEN TYPE FOUNDRY

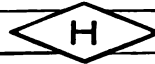

NEW DEPARTURE CASES

FULL SIZE

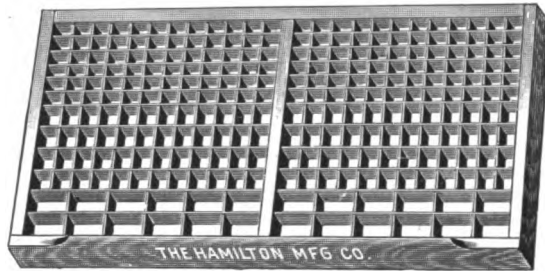

Border Case
Plain, \$1.25 With clasps, \$1.50

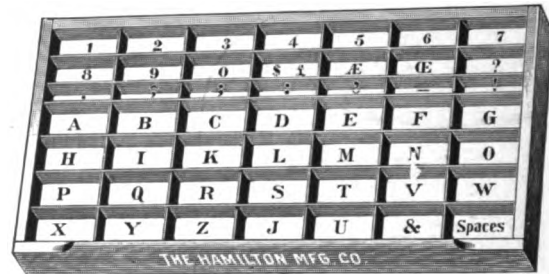

Hamilton Job Case
Plain, \$0.90 With clasps, \$1.00



Figure Case
Plain, \$1.00 With clasps, \$1.10

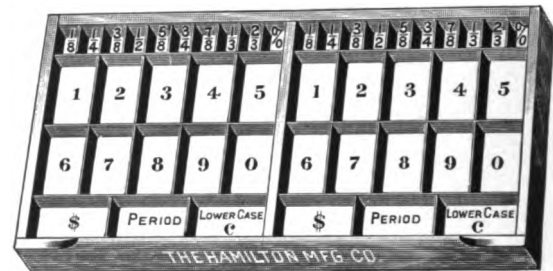

Byerly Figure Case
Plain, \$1.10 With clasps, \$1.20



Wood Type Case No. 1
Including 6 division strips Plain, \$0.90

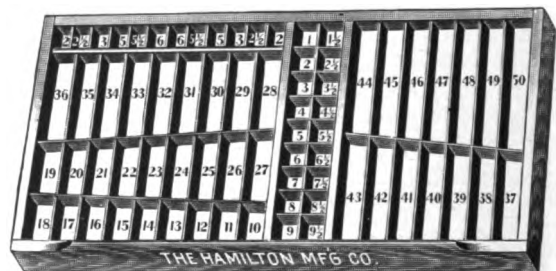

Rule Case (Ordinary)
Plain, \$1.15 With clasps, \$1.25

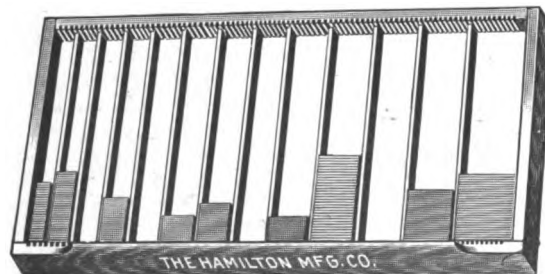

No. 1 Adjustable Lead and Slug Case
Single depth, \$1.50 Double depth, \$2.50



Neshota Rule Case
Plain, \$2.00

THE H. C. HANSEN TYPE FOUNDRY



NEW DEPARTURE CASES



Yankee Job Case. $\frac{2}{3}$ size
Plain, \$0.75 With clasps, \$0.85

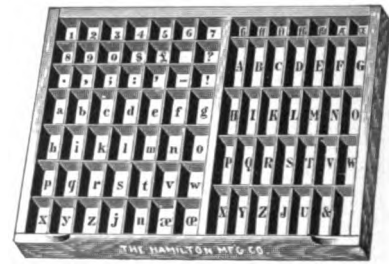

Dearing Job Case. $\frac{2}{3}$ size
Plain, \$0.75 With clasps, \$0.85



Spaceless Job Case. $\frac{2}{3}$ size
Plain, \$0.80 With clasps, \$0.90



Improved Job Case. $\frac{2}{3}$ size
Plain, \$0.90 With clasps, \$1.05

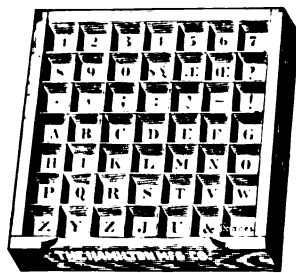

Half Cap Case
Price, \$0.60

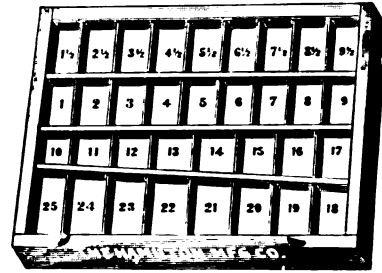

Brass Leader Case. $\frac{2}{3}$ size
Price, \$0.75

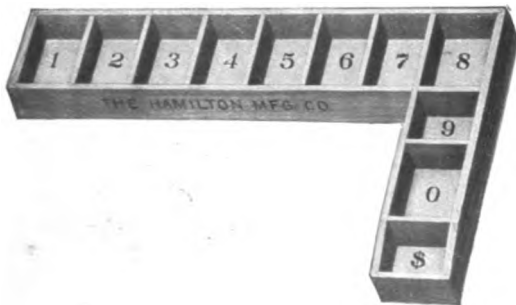

Auxiliary Figure Case No. 1
Price, \$0.65

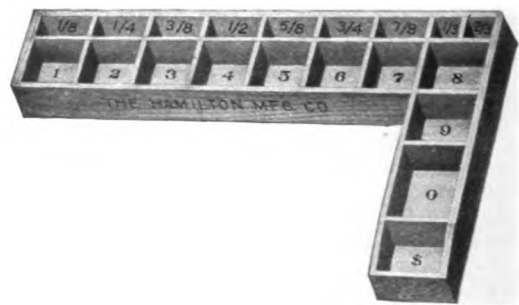

Auxiliary Figure Case No. 2
Price, \$0.75

THE H. C. HANSEN TYPE FOUNDRY



LEAD AND SLUG CASES



BETTIS LEAD AND SLUG CASE
No. 1

This case has compartments from 4 to 28 picas wide, varying by single picas, omitting the 27-em length. Partitions run from front to back without central division. Length, 72 inches; width, 18 inches, outside; depth, 1½ inches, inside. Price, \$4.00.

BETTIS LEAD AND SLUG CASE
No. 2

This case has compartments from 30 to 60 picas wide; one compartment each for 30, 32, 34, 36, 38, 40, 42, 45, 50 and 60 picas. Length, 72 inches; width, 18 inches, outside; depth, 1½ inches, inside. Price \$4.00

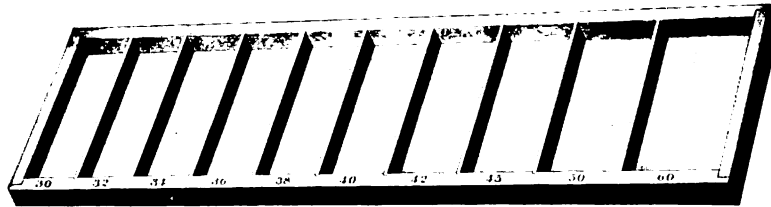

BETTIS LEAD AND SLUG CASE
No. 3

This case has compartments from 3 to 48 picas wide, varying by single picas. It also has compartments for ½ pica lengths from 3½ to 9½ picas inclusive. Length, 72 inches, width, 18 inches, outside; depth, 1½ inches inside. Price \$5.00

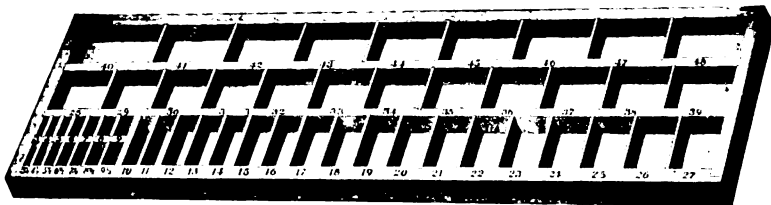

BETTIS LEAD AND SLUG CASE
No. 4

This case is the same as No. 1 and No. 2 combined, having a central bar running the long direction of the case. Length, 72 inches; width, 18 inches, outside; depth, 1½ inches, inside. Price \$5.00

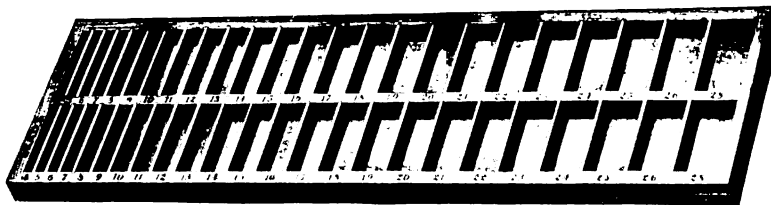
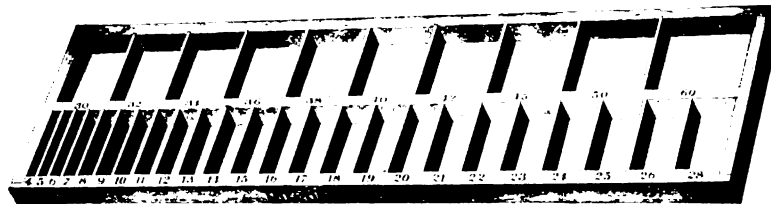

BETTIS LEAD AND SLUG CASE
No. 5

This case is same as No. 1 except that it has center bar long way dividing it in two sections which are alike. One section can be used for leads and the other for slugs. Length, 72 inches; width, 18 inches, outside; depth 1½ inches, inside. Price \$5.00

BETTIS LEAD AND SLUG CASE
No. 6

This case is a duplicate of the No. 2 except that it has center bar long way dividing it in two sections which are alike. One section can be used for leads and the other for slugs. Length, 72 inches; width, 18 inches, outside; depth, 1½ inches, inside. Price \$5.00

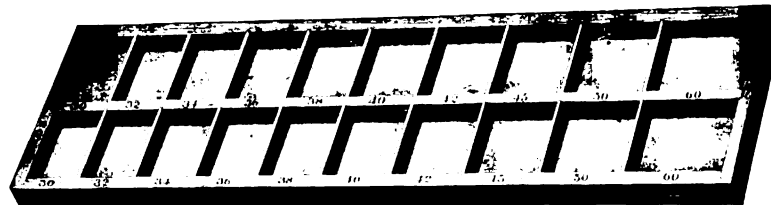

THE H. C. HANSEN TYPE FOUNDRY



LEAD AND SLUG CASES, Etc.

BETTIS LEAD AND SLUG CASE No. 7

This case represents Nos. 5 and 6 combined. Compartments are in duplicate so that leads and slugs for all lengths can be carried in separate compartments. Length, 72 inches; width, 18 inches, outside; depth, 1½ inches, inside.

Price \$6.00

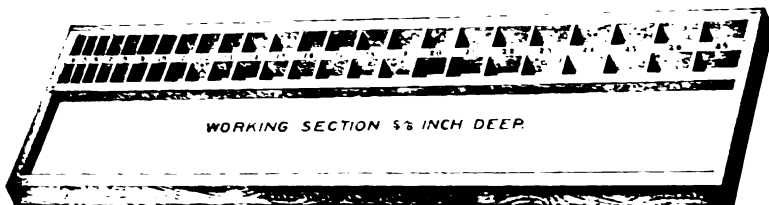
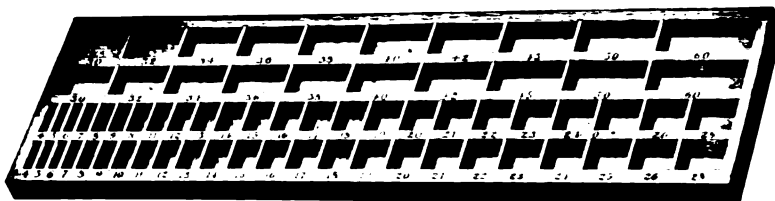

BETTIS LEAD AND SLUG CASE No. 8

Same as case No. 1 skipping the 27-em length. Blank space in front will readily take a 10 x 24 galley. Length, 72 inches; width, 18 inches, outside; depth, inside compartments, 1½ inches; working space ⅝ inch.

Price \$5.00

BETTIS SPACE AND QUAD CASE

This case provides for 14 sizes of spaces and quads, 6 boxes for each size from 6 to 48 point: large deep boxes in front are for quads and the smaller, shallower boxes in back for spaces. Depth: front, 6 inches; back, 2½ inches. Length, 72 inches; width, 18 inches, outside measurements

Price \$10.00

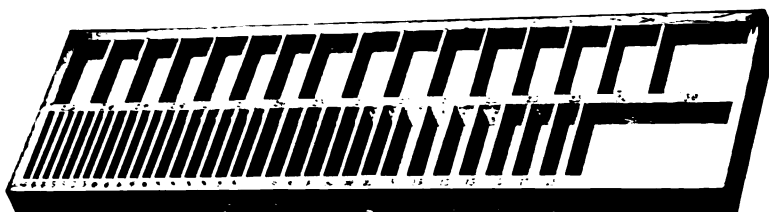

JONES METAL FURNITURE CASE

Constructed of hardwood with thick 3-ply bottom firmly fastened to the edges and also to the center bar. Being 2½ inches deep on the inside it will hold a great quantity of metal. It has 49 compartments as shown in illustration. Size, 18 x 72 inches, outside.

Price \$7 00

THIRTY-INCH SPACE AND QUAD CASE

Made to just fit inside a standard size blank case. Made to be used in connection with a blank case as a working bank. The thirty-inch case is pushed to the rear of the blank case, which leaves a space 10 inches wide for galley. Size, 4½ x 30 inches, outside.

Price \$0.75



THE H. C. HANSEN TYPE FOUNDRY

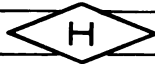

TRACY STEEL-RUN STANDS

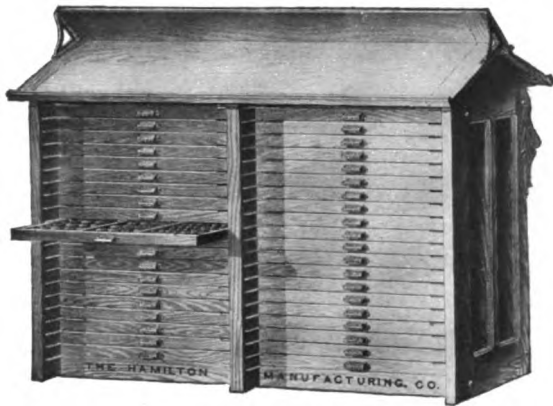

Tracy Steel-Run Stand Nos. 26 and 27. Job Case Side

No. 27 TRACY STEEL-RUN STAND

Occupies floor space 28 x 70½ inches; height at front, 43½ inches, capacity, 40 cases in body of cabinet, 20 lip-front cases in each tier. The top, on job case side, can be used as a bank or will take an 18 x 72 inch standard Bettis case. Regular pairs news cases or job cases can be used on other side of top. Under the news case bank is an additional bank for galleys or type matter, extending full length and 9 inches wide. Over this bank are two large copy drawers. Height from floor to top of bank, 56 inches. Has 5-inch extension front when cases are in position. No brackets required for this stand, Top is detachable and reversible and allows adjustment of 4 inches, throwing overhang to either side desired. Shipping weight, 440 lbs. Price \$42.00

No. 26 TRACY STEEL-RUN STAND

The No. 26 Tracy Steel-Run Stand is the same as the No. 27 described above, except for the omission of the two copy drawers and the 9-inch bank under the news case section, otherwise the two stands are identical. Top is detachable and reversible and allows adjustment of 4 inches, throwing overhang to either side desired. Shipping weight, 400 lbs.

Price.....\$35.00



No. 27 Tracy Steel-Run Stand. News Side

THE HARMS SERIES OF RULE CASES

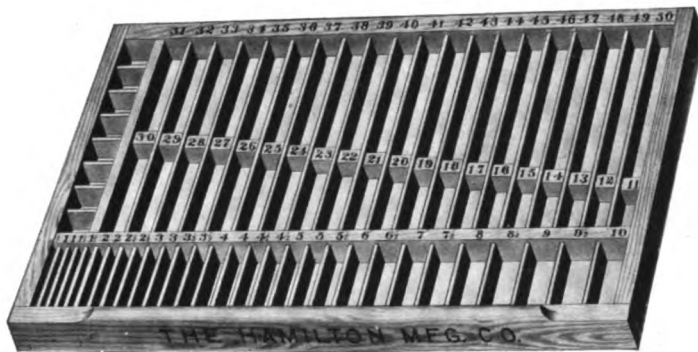

Harms Full Size Rule Case

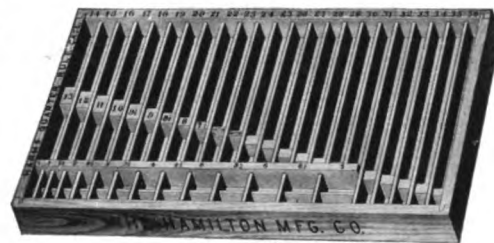

Harms Quarter Size Rule Case

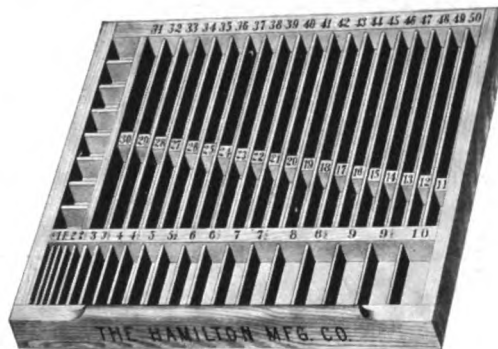

Harms Two-thirds Size Rule Case

The Harms series of rule cases, consisting of three cases, full size, two-thirds size and quarter size, are made with compartments economically arranged in natural sequence. The workman will not be confused and no time will be lost searching for desired lengths, and the mixing of various lengths in one compartment will be avoided.

- Full Size. 16½ x 32½ inches. Separate compartments for all lengths, ½ pica to 50 picas, with boxes for miters, etc..... \$2.25
- Two-thirds Size. 16½ x 21¾ inches. Separate compartments for all lengths, ½ pica to 50 picas, with boxes for miters, etc..... 1.75
- Quarter Size. 7¾ x 15½ inches. Separate compartments for all lengths, ½ pica to 36 picas, with boxes for miters, etc..... 1.25

THE H. C. HANSEN TYPE FOUNDRY



INDEXED ELECTROTYPE CABINETS

Made with steel runs. Each drawer is fitted with a metal number plate, and the Index book accompanies each cabinet without extra charge. All drawers placed in these cabinets are of the "New Departure" pattern. The cabinets are of ash, finished in antique oak. Cases are fitted with full equipment of division slats, including 5 of the slotted divisions for each drawer in the two-thirds size, and 6 for each drawer in the three-quarter and full-size cabinets; also a large assortment of cross divisions in various lengths.



Indexed Electrotyping Cabinet No. 1
With Steel Runs

No. and size of Cases	Floor Space	Price	No. and size of Cases	Floor Space	Price
No. 1 20 Two-thirds	25½x21	\$25.00	No. 10 40 Three-quarter	29½x21	\$53.00
No. 2 25 Two-thirds	25½x21	30.00	No. 11 50 Three-quarter	29½x21	65.00
No. 3 30 Two-thirds	25½x21	35.00	No. 12 60 Three-quarter	29½x21	78.00
No. 4 40 Two-thirds	25½x21	48.00	No. 13 20 Full-size	35½x21	35.00
No. 5 50 Two-thirds	25½x21	60.00	No. 14 25 Full-size	35½x21	40.00
No. 6 60 Two-thirds	25½x21	72.00	No. 15 30 Full-size	35½x21	45.00
No. 7 20 Three-quarter	29½x21	30.00	No. 16 40 Full-size	35½x21	60.00
No. 8 25 Three-quarter	29½x21	35.00	No. 17 50 Full-size	35½x21	75.00
No. 9 30 Three-quarter	29½x21	40.00	No. 18 60 Full-size	35½x21	90.00

ELECTROTYPE AND CUT CABINETS

With Wood Runs and Plain Blank Drawers

These cabinets are filled with blank drawers, and made of ash, antique finish. Drawers have extension side rails, enabling the full withdrawing of a drawer without danger of its falling out.

No. and size of Cases	Floor Space	Flat Top Price	No. and size of Cases	Floor Space	Flat Top Price
No. 1 12 Two-thirds	25½x20¾	\$12.00	No. 6 20 Three-quarters	30 x20¾	\$21.00
No. 2 16 Two-thirds	25½x20¾	14.00	No. 7 12 Full-size	35½x20¾	19.00
No. 3 20 Two-thirds	25½x20¾	16.00	No. 8 16 Full-size	35½x20¾	22.00
No. 4 12 Three-quarters	30 x20¾	15.00	No. 9 20 Full-size	35½x20¾	25.00
No. 5 16 Three-quarters	30 x20¾	18.00			

MASTERMAN COMPOSING ROOM CABINET

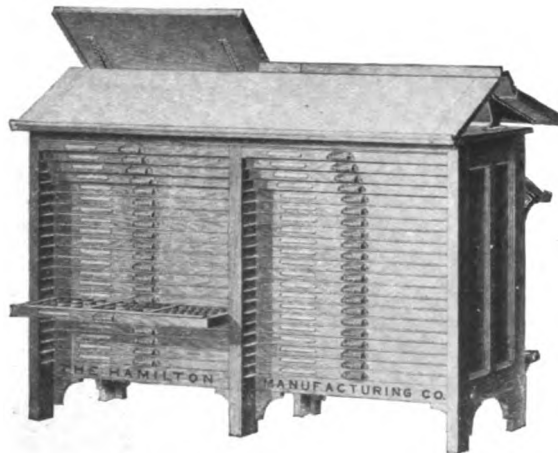

Job Side of Masterman Composing Room Cabinet

Floor space, 24 x 70 inches; height to flat top, 44 inches; two copy drawers, 12½ x 22½ x 2½ inches; galley bank under copy box 9x70 inches; lead and slug trays, 32 inches long with sloping face 23 picas wide, horizontal face, 14 picas; plain dump on job side 18 x 72 inches.

Equipment. 42 cases in body of cabinet; 2 pairs No. 18 brackets with detachable upper arms; 2 job cases for the top, interchangeable with cases in cabinet; 2 double surface galley boards, 32 inches long.

Complete with cases, brackets, copy box, and 18-inch bank \$90.00
 Extra for galley dump under copy drawers..... 5.00
 Extra for polished and blued foot rail..... 6.00
 Extra for label-holder mortises in case fronts, celluloid covers 2.50

It has detachable upper bracket arms, so that the top cases can be used in low form, dispensing with the cap case, and using job cases only, or by extending the brackets, pairs of news cases can be used in the usual form. Illustrations show both equipments. Where job cases are used on lower part of brackets it leaves room for storage of leads and slugs. The four upper cases in each tier project from case line, as shown. This allows these upper cases to be withdrawn, they having extension rails, so that the back compartments are accessible without taking the cases from the rack.

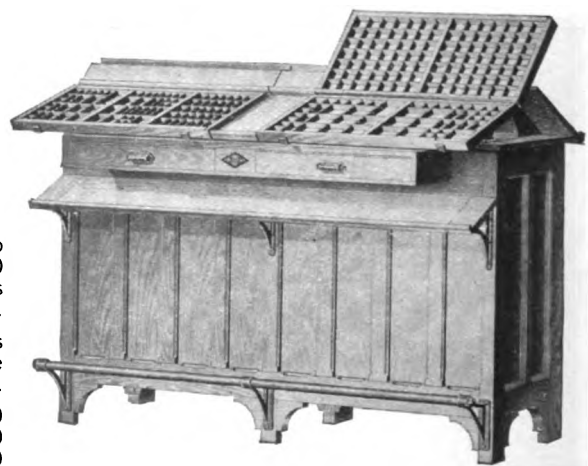

News Side of Masterman Composing Room Cabinet

THE H. C. HANSEN TYPE FOUNDRY



No. 11 Double Job Stand

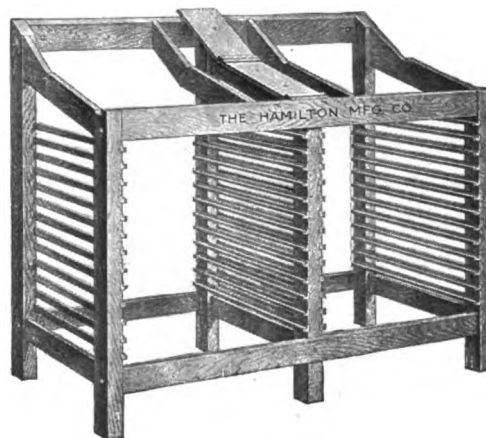

No. 15 Double Stand

PRICE LIST OF CASE STANDS

No.	Description	Floor Space	Weight	Price
1	Single, without racks.....	26 x 36 $\frac{1}{2}$	32	\$2.75
2	Single, with racks for 12 two-thirds cases.....	26 x 25 $\frac{1}{2}$	38	3.00
2 $\frac{1}{2}$	Single, with racks for 12 three-quarter cases....	26 x 30 $\frac{1}{2}$	42	3.00
3	Single, with racks for 8 full size cases.....	26 x 36 $\frac{1}{2}$	39	3.00
4	Single, with racks for 12 full size cases.....	26 x 36 $\frac{1}{2}$	45	3.25
5	Double News, without racks.....	26 x 60	50	3.25
6	Double News, with racks for 8 full size cases...	26 x 60	55	3.75
7	Double News, with racks for 10 full size cases..	26 x 60	56	4.25
8	Double News, with racks for 12 full size cases..	26 x 60	58	4.75
9	Double Job Stand with racks for 8 full size and 8 two-thirds cases.....	26 x 60	61	4.25
10	Double Job Stand, with racks for 10 full size and 10 two-thirds cases.....	26 x 60	65	5.00
11	Double Job Stand, with racks for 12 full size and 12 two-thirds cases.....	26 x 60	70	5.50
12	Double Job Stand, with racks for 12 full size and 12 three-quarter cases.....	26 x 64 $\frac{1}{2}$	72	5.75
13	Double Stand, with galley rest and racks for 16 full size cases.....	26 x 70 $\frac{1}{2}$	70	5.50
14	Double Stand, with galley rest and racks for 20 full size cases.....	26 x 70 $\frac{1}{2}$	74	5.75
15	Double Stand, with galley rest and racks for 24 full size cases.....	26 x 70 $\frac{1}{2}$	78	6.00
16	Double Stand, with galley rest and racks for 30 full size cases.....	26 x 70 $\frac{1}{2}$	83	7.00

Paneled ends to any of above stands, \$2.00 extra.



No. 4 Single Stand

PRICE LIST OF CASE RACKS

No.	Capacity	Height Inches	Floor Space	Weight	Plain	Closed back and sides
20	Single tier 10 full size cases	38	20 $\frac{1}{2}$ x 36 $\frac{1}{2}$	45	\$ 5.50	\$ 7.75
21	Single tier 12 full size cases	41	20 $\frac{1}{2}$ x 36 $\frac{1}{2}$	49	6.00	8.50
22	Single tier 16 full size cases	50	20 $\frac{1}{2}$ x 36 $\frac{1}{2}$	56	7.00	9.50
23	Single tier 20 full size cases	60	20 $\frac{1}{2}$ x 36 $\frac{1}{2}$	58	8.00	11.00
24	Single tier 24 full size cases	70	20 $\frac{1}{2}$ x 36 $\frac{1}{2}$	67	9.00	12.00
25	Single tier 30 full size cases	84	20 $\frac{1}{2}$ x 36 $\frac{1}{2}$	83	10.00	13.00
26	D'ble tier 40 full size cases	60	20 $\frac{1}{2}$ x 70 $\frac{1}{2}$	104	14.00	17.00
27	D'ble tier 60 full size cases	84	20 $\frac{1}{2}$ x 70 $\frac{1}{2}$	144	18.00	22.50

All Case Stands and Racks are furnished unfinished and shipped knocked down.

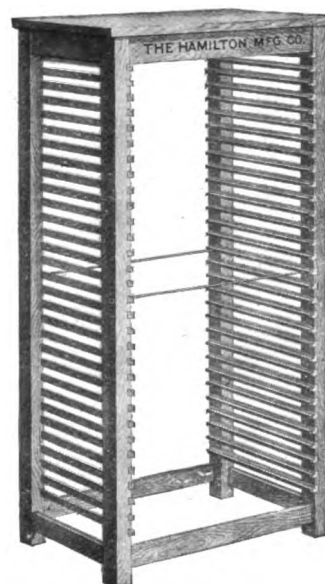

No. 25 Thirty Case Rack

THE H. C. HANSEN TYPE FOUNDRY

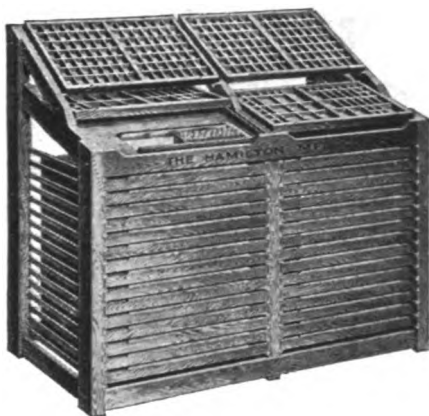

Double City Stand

CITY STANDS

The upper case projects forward over the lower, bringing it nearer the compositor, who sets caps with greater ease than from the ordinary stand. Under lower case there is a shelf for galley.

No. 1. Single, with racks for 15 full size cases; occupies floor space 26 x 36 inches.

List Price, \$5.75

No. 2. Double, with racks for 30 full size cases; occupies floor space 26 x 70½ inches.

List Price, \$8.00

The prices given are for stands only and do not include cases.



No. 2 New York Double Case Stand

NEW YORK STANDS

The lower cases project into the alley several inches, affording the compositor ample knee room. The angle of the lower case is just right for rapid setting.

- No. 1. New York Single Stand, 15 cases and 1 pair on top, floor space 18 x 36½ inches..... \$ 6.50
- No. 2. New York Double Stand, 30 cases and 2 pairs on top, floor space 18 x 70½ inches..... 10.50
- No. 3. New York Quadruple Stand, 60 cases and 4 pairs on top, floor space 35 x 70½ inches..... 18.00
- No. 4. New York Window Stand, 30 cases and two pairs on top, floor space 35 x 36½ inches..... 10.50

Prices include the brackets, but not the cases on top.



Wesel Wrought Iron Case Stand No. 5

WESEL WROUGHT IRON CASE STANDS

Made of the best grade of wrought iron piping, and are accurately joined at all intersections by substantial castings having large threads, the double stands being braced by two transverse braces in the rear not shown in the illustrations. They are practically indestructible. Made for full size, three-quarter or Rooker cases at the same prices. Extra runs riveted to stands at 40 cents per pair, list.

- No. 1. Single, without Racks..... \$ 9.00
- No. 2. Single, with 8 Racks..... 12.00
- No. 3. Single, with 8 Racks and Galley Rest..... 13.00
- No. 4. Double, without Racks..... 12.00
- No. 5. Double, with 8 Racks..... 15.00
- No. 6. Double, with 8 Racks and Galley Rest..... 18.00
- No. 7. Double, with 8 Racks, Galley Rest and 16 Galley Racks..... 25.00
- No. 8. Double, with 8 Racks for full size and 8 Racks for two-third cases 19.00
- No. 9. Double, with 16 Racks and Galley Rest..... 20.50
- No. 10. Double, with 8 Racks for full size and 8 Racks for two-thirds size cases, Galley Rest and 16 Galley Racks..... 30.00



Wesel Wrought Iron Case Stand No. 9

ROWEN BORDER AND SCRIPT TYPE CABINETS

Invaluable for the life and preservation of delicate borders and script faces which soon become battered and worn by friction when thrown in the ordinary type or border cases.

- No. 1. 4 Drawers, one tier.... \$ 8.00
- No. 2. 6 Drawers, one tier.... 10.50
- No. 3. 10 Drawers, one tier.... 16.00
- No. 4. 16 Drawers, two tiers.... 25.00
- No. 5. 20 Drawers, two tiers.... 30.00
- No. 6. 30 Drawers, two tiers.... 45.00
- No. 7. 40 Drawers, two tiers.... 60.00



No. 2 Rowen Border and Script Type Cabinet

THE H. C. HANSEN TYPE FOUNDRY

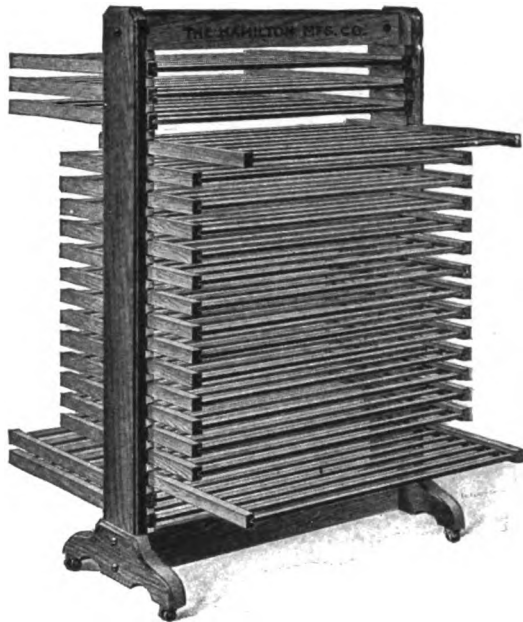
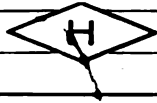

New York Drying Rack

NEW YORK DRYING RACK

The New York Dryers are removable and can be transferred to the press in order to take the sheets direct from the fly. Thus undue handling, which means an excess of spoilage, is avoided. The use of these dryers prevents the over stacking of freshly printed sheets, and also expensive slip sheeting is reduced to a minimum. The Frames are made to take 20 or 30 dryers as desired. The dryers are made in two sizes—No. 1 and 2 take sheets 24 x 36 inches, Nos. 3 and 4 take sheets 28 x 42 inches.

	Description	Complete	Racks Only	Shelves per doz.
No. 1	20 shelves, 24 x 36.....	\$22.75	\$12.00	\$6.50
No. 2	30 " 24 x 36.....	32.00	15.75	6.50
No. 3	20 " 28 x 42.....	28.75	12.75	9.60
No. 4	30 " 28 x 42.....	40.50	16.50	9.60

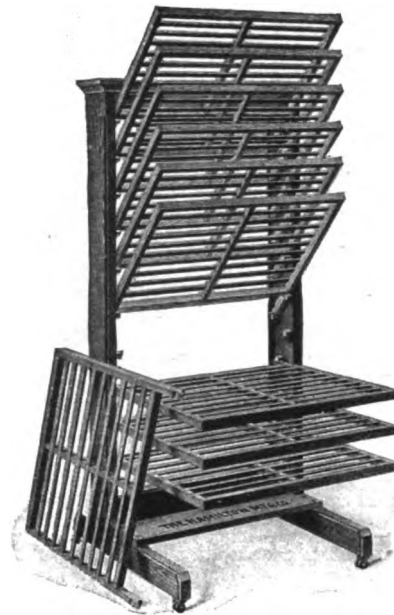

Chicago Drying Rack

CHICAGO DRYING RACK

These drying racks are substantially constructed of hardwood, and framework is finished in best cabinet style.

The Chicago Drying Racks differ from the New York Rack in the manner of placing drying shelves into the upright rack. The side rails extend at the rear and are notched to receive round lugs which project from the frame upright. When loaded the dryers can be placed in a horizontal position, and when not loaded they can be inclined upward and out of the way until required.

	Description	Complete	Racks Only	Shelves per doz.
No. 5	12 shelves, 24 x 24.....	\$20.25	\$12.50	\$ 7.75
No. 6	10 " 24 x 36.....	22.00	14.00	9.60
No. 7	10 " 30 x 48.....	32.25	21.00	13.50

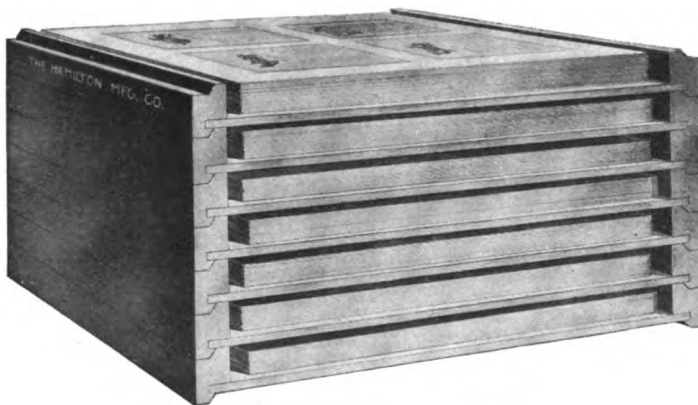

Interlocking Racks stacked with paper, straight and rigid

KOERNER'S PATENT INTERLOCKING DRYING RACKS

The interlocking device, which makes the pile straight and rigid, is shown in illustration. Each rack is firmly locked on its neighbor, but each slides with ease on the rack immediately below it. They may be stacked ceiling high in a perfectly straight and rigid pile, which cannot be knocked over by accident.

8 1/2 x 13 inches	\$0.20	24 x 36 inches	\$0.55
11 x 17 "	.25	32 x 48 "	.85
13 x 19 "	.30	38 x 52 "	1.20
15 x 21 "	.35	43 x 63 "	1.55
18 x 25 "	.45	45 x 65 "	1.60

THE H. C. HANSEN TYPE FOUNDRY



CASE RACKS, GALLEY BRACKETS, ETC.

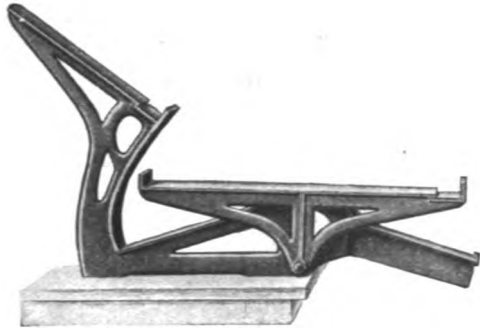

No. 1 HAMILTON PATENT TILTING BRACKET
 This bracket takes a pair of standard size news cases. The lower case can be tilted back to expose the galley board underneath. The tilting feature is also convenient for shaking the lower case to even up the type boxes.
 Price, per pair, \$2.00

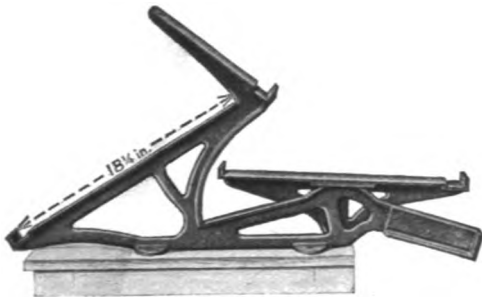

No. 2 HAMILTON PATENT THREE CASE TILTING BRACKET
 Takes a pair of standard news cases at the front, and an 18 inch working bank or standard size Bettis lead and slug case at the rear. Has the tilting feature, and is furnished with the galley board which goes under the lower case.
 Price, per pair, \$2.40

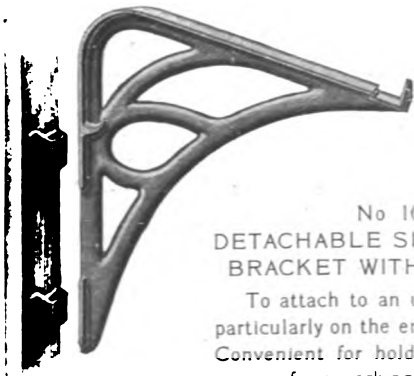

**No. 10
 DETACHABLE SINGLE CASE BRACKET WITH SOCKETS**
 To attach to an upright surface, particularly on the end of a cabinet. Convenient for holding a full size case or for a working bank.
 Price, per pair, \$2.00

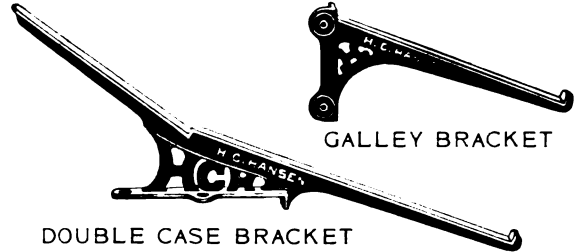

DOUBLE CASE BRACKET
 The Double Case Bracket can be screwed to the top of a cabinet, table, shelf, or any flat surface.
 Double Case Bracket, per pair, \$1.25
 Galley Brackets, per pair, .40

GALLEY RACKS
 These racks will hold a large quantity of matter in a small space, being screwed to the wall they are out of the way and utilize space which otherwise might be wasted.

For 6 galleys.....	\$2.50
" 12 "	5.00
" 18 "	7.50



No. 13 ROLLER BRACKET
 To attach to a perpendicular surface. Bracket arms extend horizontally. A pair of brackets will hold six rollers
 Price, per pair \$0.50

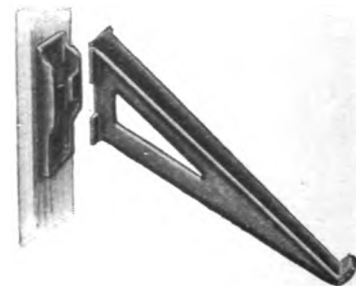

No. 14 DETACHABLE GALLEY BRACKET WITH SOCKET
 To attach to a perpendicular surface. Per pair, \$0.40

THE H. C. HANSEN TYPE FOUNDRY



No. 2 Wisconsin Window Cabinet



No. 27 Flat Top 20 Case Wisconsin Cabinet

WISCONSIN CABINETS

The Wisconsin Cabinets are made in ash, antique finish, this wood being very handsome and of unusual strength, with excellent staying qualities.

LIST PRICES OF WISCONSIN WOOD RUN CABINETS

No.	No. of Cases	Height Inches	Floor Space Inches	Weight	Flat Top	Galley Top
19	12 Two-thirds Cases ...	34½	25½ x 20½	140	\$15.00	\$18.00
20	16 Two-thirds Cases ...	43	25½ x 20½	170	18.00	21.00
21	20 Two-thirds Cases ...	43	25½ x 20½	190	21.00	24.00
22	12 Three-quarter Cases	34½	29½ x 20½	180	18.00	21.00
23	16 Three-quarter Cases	43	29½ x 20½	215	22.00	25.00
24	20 Three-quarter Cases	43	29½ x 20½	235	26.00	29.00
25	12 Full Size Cases....	34½	35½ x 20½	190	22.00	25.00
26	16 Full Size Cases....	43	35½ x 20½	235	26.00	29.00
27	20 Full Size Cases....	43	35½ x 20½	270	30.00	33.00

WISCONSIN WINDOW CABINETS

No. 1. With Wood Runs, 18 full size California Job Cases, 2 pairs of News Cases and 2 pairs of Tilting Brackets No. 1 on top.
Price, \$36.00

No. 2. With Steel Runs, 23 full size California Job Cases, 2 pairs of News Cases and 2 pairs of Tilting Brackets No. 1 on top.
Price, \$47.00

FLAT TOP CABINET BRACKETS

No. 6 Style A Double Case Bracket Pair \$1.50
 No. 7 Style B Double Case Bracket 1.25
 No. 1 Hamilton Patent Tilting Bracket 2.00
 No. 2 Three-Case Tilting Bracket 2.40
 No. 4 Three-Case Bracket 1.90

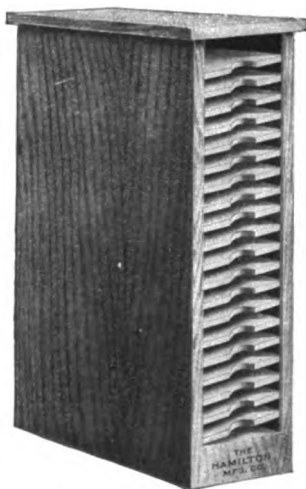

No. 7 Flat Top Cabinet with Flat Ends

HAMILTON'S GALLEY CABINETS

Practically indestructible and made to carry safely the heavy loads to which they must necessarily be subjected.

GALLEY TOPS AND PANELED SIDES

No.	Galley	Price	Extra for No. Plate
No. 1.	22 d'ble galleys,	\$14.00	\$1.10
No. 2.	44 " "	25.00	2.20
No. 3.	66 " "	36.00	3.30
No. 4.	88 " "	47.50	4.40
No. 5.	132 " "	62.00	6.60
No. 6.	198 " "	85.00	9.90

FLAT TOP AND FLAT SIDES

No.	Galley	Price	Extra for No. Plate
No. 7.	20 d'ble galleys,	\$ 8.00	\$1.00
No. 8.	30 " "	11.50	1.50
No. 9.	40 " "	15.00	2.00
No. 10.	60 " "	22.00	3.00



No. 5 Galley Top Cabinet with Paneled Ends

THE H. C. HANSEN TYPE FOUNDRY



PORTER'S PATENT EXTENSION FRONT STEEL-RUN CABINETS

No other cabinet equals this in points of solidity and carrying capacity. The runs are flat pieces of steel, which are placed between strips of wood as shown in illustration, and a steel rod is run from top to bottom of the cabinet through the steel runs and intervening wooden strips and then firmly locked with steel pins. The wooden strips are firmly fastened to the side rails of the cabinet.

All cabinets are fitted with the patented New Departure California Job Cases. The merits of this case are well known. They ride upon the side rails only, and the bottoms do not come in contact with the case runs.

Cabinets Nos. 6 and 7 have paneled backs. Other Cabinets of this series have plain backs.

The floor space occupied by Nos. 1 to 6 is 35½ x 22 inches; No. 7, 69¼ x 22 inches.

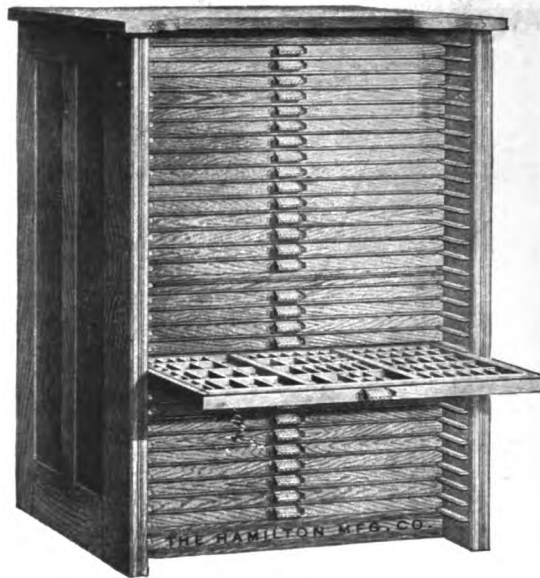

No. 2 Porter Extension Front Steel-Run Cabinet

LIST PRICES OF PORTER EXTENSION FRONT STEEL RUN CABINETS

No. 1	With 25 Cases, Single Tier, Flat Top.....	\$ 43.00
No. 2	With 30 Cases, Single Tier, Flat Top.....	51.00
No. 3	With 40 Cases, Single Tier, Flat Top.....	68.00
No. 4	With 50 Cases, Single Tier, Flat Top.....	85.00
No. 5	With 60 Cases, Single Tier, Flat Top.....	100.00
No. 6	With 23 Cases, Single Tier, with 1 pair No. 1 Tilting Brackets and one pair of News Cases on top.....	45.00
No. 7	With 46 Cases, Double Tier, with 2 pairs No. 1 Tilting Brackets and two pairs of News Cases on top.....	90.00

TWENTIETH CENTURY UNIT TYPE CASES

The Units can be added to the equipment of an office from time to time as stock increases, and there will never be many type cases not in actual use. The Units can be built up in sections around windows and in other places where it is not possible to put an ordinary cabinet.

LIST PRICES OF TWENTIETH CENTURY UNITS

No. 50	10 Cases, various depths.....	\$17.50
No. 51	10 Cases, equal depth.....	17.00
No. 52	8 Cases, equal depth.....	15.00
No. 53	6 Cases, equal depth.....	13.00
No. 54	8 Blank Cases, equal depth.....	13.00
No. 55	8 Indexed Electrotpe Cases.....	16.00
No. 60	Cap Piece with Drawer and 60 removable Sort Boxes.....	7.50
No. 61	Cap Piece, Plain.....	3.00
No. 62	Base Piece.....	1.50

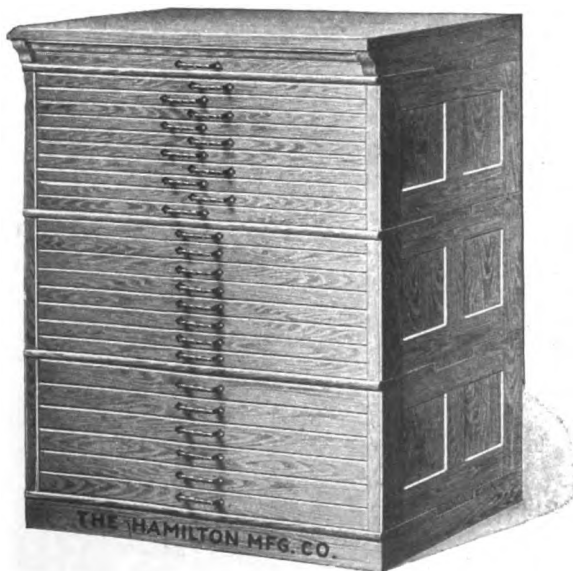

Twentieth Century Units Nos. 51, 52 and 53 Combined
With Cap Piece No. 60 and Base No. 62

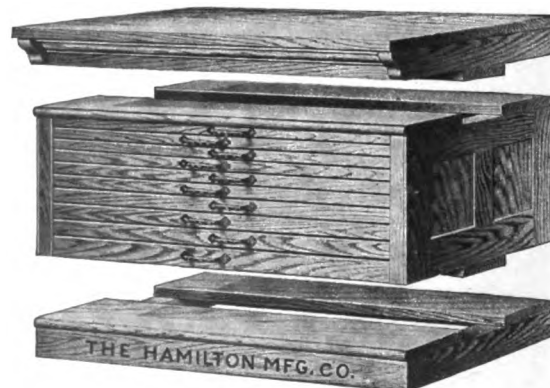

Twentieth Century Unit No. 50
With Cap Piece No. 61 and Base No. 62

THE H. C. HANSEN TYPE FOUNDRY



New Departure Cabinet No. 62

NEW DEPARTURE TYPE CABINETS

With Flat Steel Runs and "New Departure" Cases.

Where compactness is essential in saving space the New Departure Cabinets are recommended. In points of strength and beauty they are unsurpassed.

They are constructed of hardwood, finished antique; the ends are tastefully paneled and moulded, and the fronts ornamented and fitted with bronzed pulls. The cases are our best "New Departure" pattern covered with paper on the inside; the paper absorbs the moisture and prevents it from entering the bottom.

PRICES OF NEW DEPARTURE CABINETS

No.	No. of Cases	Tiers	Size of Cases	Floor Space Inches	Height inches	Price
50	25	1	Two-thirds	21 x 24 $\frac{3}{4}$	43	\$ 29.00
51	33	1	Two-thirds	21 x 24 $\frac{3}{4}$	43	37.00
52	30	1	Two-thirds	21 x 24 $\frac{3}{4}$	52	34.50
53	40	1	Two-thirds	21 x 24 $\frac{3}{4}$	67	45.50
54	50	1	Two-thirds	21 x 24 $\frac{3}{4}$	82	56.50
55	50	2	Two-thirds	21 x 49 $\frac{1}{2}$	43	57.00
56	25	1	Three-quarters	21 x 29 $\frac{1}{2}$	43	34.50
57	33	1	Three-quarters	21 x 29 $\frac{1}{2}$	43	43.00
58	30	1	Three-quarters	21 x 29 $\frac{1}{2}$	52	39.50
59	40	1	Three-quarters	21 x 29 $\frac{1}{2}$	67	52.00
60	50	1	Three-quarters	21 x 29 $\frac{1}{2}$	82	63.50
61	50	2	Three-quarters	21 x 58 $\frac{1}{2}$	43	64.25
62	25	1	Full Size	21 x 35 $\frac{1}{2}$	43	38.75
63	33	1	Full Size	21 x 35 $\frac{1}{2}$	43	49.00
64	28	1	Full Size	21 x 35 $\frac{1}{2}$	43	42.50
65	30	1	Full Size	21 x 35 $\frac{1}{2}$	52	45.00
66	40	1	Full Size	21 x 35 $\frac{1}{2}$	67	59.25
67	50	1	Full Size	21 x 35 $\frac{1}{2}$	82	72.50
68	50	2	Full Size	21 x 69 $\frac{1}{2}$	43	74.00
69	66	2	Full Size	21 x 69 $\frac{1}{2}$	43	93.00
70	56	2	Full Size	21 x 69 $\frac{1}{2}$	43	81.00
71	20	1	Full Size	21 x 35 $\frac{1}{2}$	43	38.00
72	78	3	Full Size	21 x 103 $\frac{1}{2}$	43	113.00

Prices given are for flat top cabinets. Galley tops, extra: for single tier cabinets, \$3.00; for double tier cabinets, \$6.00.

ANNEX TYPE BOX

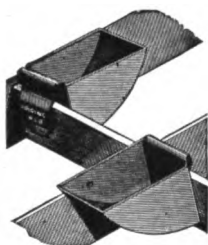

This is a brass cup which can readily be attached to the boxes of the lower case. They are very useful for holding leaders, fractions, and other sorts required for special jobs.

Each.....\$0.20
Per dozen..... 2.25

WOOD TYPE CABINETS

Wood type cabinets are made to hold two sizes of cases, viz.: Nos. 1, 2, 3, 7 and 8 hold cases 23 x 32 $\frac{1}{2}$ inches; Nos. 4, 5, 6, 9 and 10 hold cases 23 x 44 inches. The cases are slotted on the sides and have movable strips adjustable to picas.

PRICES OF WOOD TYPE CABINETS

No.	Steel or Wood Runs	No. of Cases	Floor Space Inches	Flat Top Price	Galley Top Price
1	Wood Runs	12	35 $\frac{1}{2}$ x 26 $\frac{1}{2}$	\$ 24.00	\$ 27.50
2	Wood Runs	16	35 $\frac{1}{2}$ x 26 $\frac{1}{2}$	30.00	33.50
3	Wood Runs	20	35 $\frac{1}{2}$ x 26 $\frac{1}{2}$	36.00	39.50
4	Wood Runs	12	47 $\frac{1}{2}$ x 26 $\frac{1}{2}$	30.00	34.00
5	Wood Runs	16	47 $\frac{1}{2}$ x 26 $\frac{1}{2}$	40.00	44.00
6	Wood Runs	20	47 $\frac{1}{2}$ x 26 $\frac{1}{2}$	48.00	52.00
7	Steel Runs	25	35 $\frac{1}{2}$ x 26 $\frac{1}{2}$	46.50	50.00
8	Steel Runs	50	69 $\frac{1}{2}$ x 26 $\frac{1}{2}$	87.00	94.00
9	Steel Runs	25	47 $\frac{1}{2}$ x 26 $\frac{1}{2}$	63.00	67.00
10	Steel Runs	50	93 $\frac{1}{2}$ x 26 $\frac{1}{2}$	118.00	125.00

The cabinets Nos. 8 and 10 with steel runs and 50 cases are double tier, 25 cases in each tier. Six division strips sent with every case in a cabinet. Extra strips 2 cents each.



Wood Type Cabinet No. 9

THE H. C. HANSEN TYPE FOUNDRY



THE POLHEMUS CABINETS

The Polhemus Cabinets concentrate the type case equipment into the smallest possible floor space. At the same time it gives more room and relieves the congestion.

These Cabinets are built in the best manner and nicely finished. Prices quoted are for ash with antique finish Cabinets are made flush with floor to prevent dirt from getting underneath.

COMPLETE LIST PRICES AND DESCRIPTIONS OF ALL POLHEMUS CABINETS

No. 1
 Double Polhemus Cabinet with wood runs, containing 18 full size California Job Cases in one tier and 20 two-third size California Job Cases in one tier, two pairs of News Cases and two pairs of No. 1 Hamilton Patent Tilting Brackets on top. Galley Boards under the lower cases. Full length Galley Dump and one tier of ten Sort Drawers between the two tiers of cases.....\$ 75.00

No. 2
 Single Polhemus Cabinet with wood runs, containing 18 full size California Job Cases in one tier, one pair of News Cases and one pair of No. 1 Hamilton Patent Tilting Brackets on top. Galley Board under lower case. Full length Galley Dump..... 35.00

No. 3
 Triple Polhemus Cabinet with wood runs, containing 40 two-thirds size California Job Cases in two tiers, 20 cases in each tier, 18 full size California Job Cases in one tier, three pairs of News Cases and three pairs No. 1 Hamilton Patent Tilting Brackets on top, with Galley Boards under lower cases. Full length Galley Dump, one tier of Sort Drawers and series of Galley Shelves between the tiers of Cases.. 110.00

No. 4
 Triple Polhemus Cabinet with Steel runs, containing 50 two-thirds size California Job Cases, 25 cases in each tier, and 25 full size California Job Cases in the center tier, three pairs of News Cases and three pairs of No. 1 Hamilton Patent Tilting Brackets on top. Galley Boards under lower cases. Full length Galley Dump, one tier of Sort Drawers and one tier of Galley Shelves 140.00

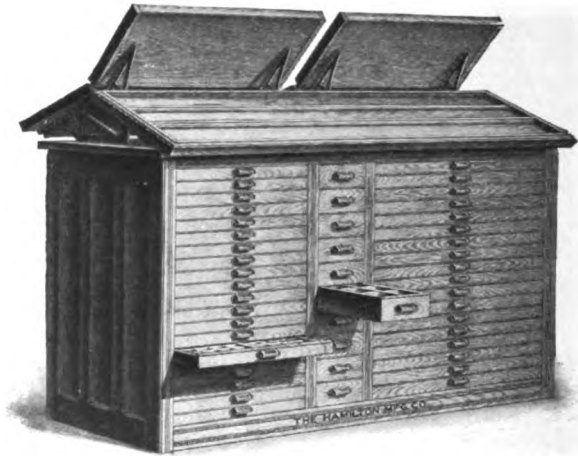

Front View of No. 1 Double Polhemus Cabinet

No. 5
 Double Polhemus Cabinet with steel runs, containing 25 full size California Job Cases in one tier and 25 two-thirds size California Job Cases in one tier, two pairs of News Cases and two pairs of No. 1 Hamilton Patent Tilting Brackets on top. Galley Boards under lower cases. Full length Galley Dump and one tier of Sort Drawers between the two tiers of cases.\$ 95.00

No. 6
 Double Polhemus Cabinet with steel runs, containing 50 full size California Job Cases, 25 in tier, two pairs of News Cases and two pairs of No. 1 Hamilton Patent Tilting Brackets on top. Galley Boards under lower cases. Full length Galley Dump. Without Sort Drawers or Galley Cabinet..... 95.00

No. 7
 Single Polhemus Cabinet with steel runs, containing 25 full size California Job Cases, one pair of News Cases and a pair of No. 1 Hamilton Patent Tilting Brackets on top. Galley Board under lower case. Full length Galley Dump..... 47.00

No. 8
 Double Polhemus Cabinet with steel runs, containing 25 full size California Job Cases in one tier and 25 two-thirds size California Job Cases in one tier, two pairs News Cases and two pairs No. 1 Hamilton Patent Tilting Brackets on top. Galley Boards under lower cases. Full length Galley Dump and tier of Galley Shelves between the two tiers of cases 95.00

No. 9
 Double Polhemus Cabinet with wood runs, containing 18 full size California Job Cases in one tier and 20 two-thirds size California Job Cases in one tier, two pairs of News Cases and two pairs of No. 1 Hamilton Patent Tilting Brackets on top. Galley Boards under lower cases. Full length Galley Dump and tier of Galley Shelves between the tiers of cases.... 75.00

For full brass lined Dumps on these Cabinets, add to list prices as follows:

- Nos. 2 and 7\$13.00
- Nos. 1, 5, 6, 8 and 9 24.00
- Nos 3 and 4 35.00

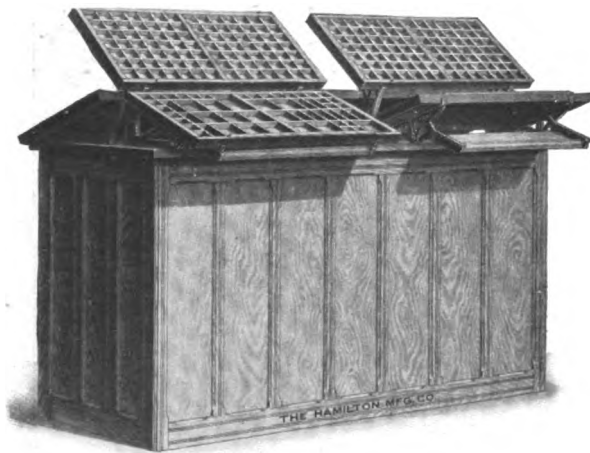

Rear View of Double Polhemus Cabinets, Nos. 1, 5, 6, 8 and 9

THE H. C. HANSEN TYPE FOUNDRY



MASTODON CABINET

With Lead and Slug Bank

Combining Letter Board Cabinet, Sort Cabinet, Indexed Electrotpe Cabinet, Galley Cabinet and Metal Furniture Cabinet.

Brass Lined Lead and Slug Bank—On each side the sloping brass-lined top is divided into compartments for leads and slugs from 4 to 50 ems, with extra compartments for 54-em lengths. 1500 pounds of leads and slugs can be stored on single depth and 3000 pounds on double depth bank.

End Drawers—There are three drawers in the end under the sloping top. These drawers are 10 feet long and can be drawn from either end. They run on steel rollers and will hold hundreds of pounds of metal furniture

Sort Drawers—There are twenty sort drawers 47 inches long, 9 inches wide and 3 inches deep. These drawers run on steel rollers, which gives easy motion when heavily loaded.

Indexed Electrotpe Cases—There are forty-six indexed electrotpe cases 15 x 30½ inches inside. They are fitted with a full complement of division strips, both the double slotted and plain kind, and an index book is furnished without extra charge.

Letter Boards—There are thirty letter boards on one side, 15 boards 30½ x 24 inches, and 15 boards 25½ x 19½ inches. These letter boards have a lip at front edge to receive galley, so that type can be readily pushed from the boards to galley.

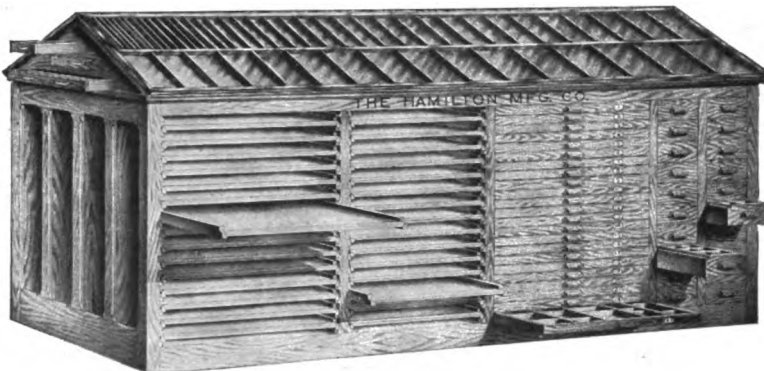

Showing one side of Mastodon Cabinet. See illustration below for other side

Galley Cabinets—There are six tiers of galley shelves, inclined, with accommodations for 114 galleys. Four tiers of 19 each are for double column galleys and two tiers are for single column galleys. These shelves are numbered with metal number plates from 1 to 114 inclusive.

Dimensions—Length, 10 feet and ¼ inch; width, 47 inches; height at front of lead bank, 43 inches; height at the center, 56 inches; width of lead bank, 26½ inches on each side, and each side is divided into two equal divisions of 12½ inches.

The weight of this piece of furniture, complete, ready for shipment, is 2380 pounds.

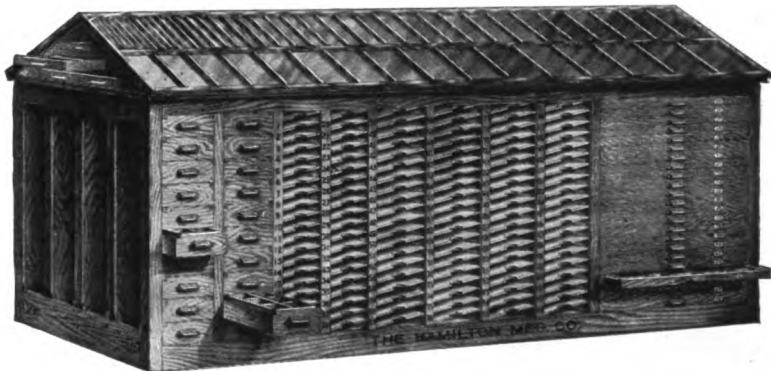

Showing one side of Mastodon Cabinet. See illustration above for other side

List Prices

Made in one piece, complete.....	\$375.00
Made in sections, knock-down form	400.00
Extra to list price for double depth brass lined lead and slug bank...	50.00

INK AND ROLLER CABINETS



Ink and Roller Cabinet

No. 1—With shelf for ink, shelf for brayers and slabs, and brackets to hold 6 eighth and 6 quarto rollers. Height, 36½ inches; floor space, 27½ x 15 inches. List price..... \$6.50

No. 2—With shelf for ink, shelf for brayers and slab, and brackets for 6 each eighth, quarto, and half medium rollers. Height, 36½ inches; floor space, 33½ x 15 inches. List price..... \$9.50

No. 3—With shelf for ink, shelf for brayers and slab, and brackets for 12 each eighth, quarto, and half-medium rollers. Height, 48½ inches; floor space, 33½ x 15 inches. List price..... \$13.00

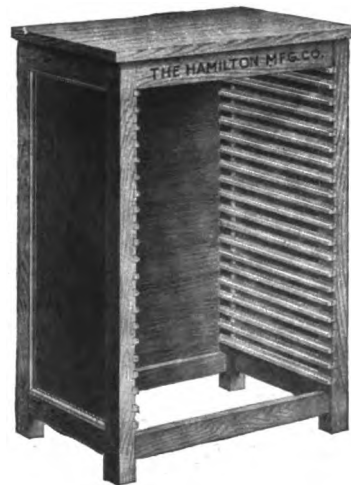

No. 25 Twenty Case Rack, closed back and sides
For price see page 297



MONOTYPE WORK BENCH

This bench is made of ash, finished antique. The top is of maple plank, built of pieces grooved together, and first-class in every respect.

The dimensions of the bench are as follows: length of top, 72½ inches; width, 36 inches; height from floor to top, 35 inches; back board, 4 inches high. There are two drawers, each 5½ inches deep, 24½ inches wide, 28½ inches long, inside measure. Cupboard 26 x 30 inches, 19½ inches high. Flywheel compartment, 6 inches wide, 32 inches deep, 26½ inches high. Weight, complete, ready for shipment, 350 pounds.

This Bench includes the raised triangle at the corner, which supports the cabinet, but does not include the cabinet.

List Price, without vise or cabinet on top. . . . \$48.00

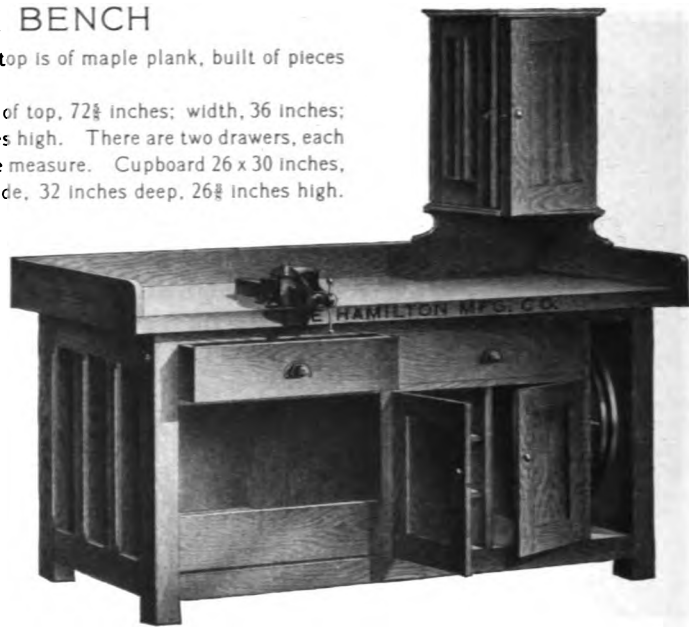

Monotype Work Bench

MONOTYPE CABINET

Especially designed to embody the ideas of monotype users and operators for a safe and convenient place for holding all accessories to the monotype casting machine when not in use. The door is arranged with holders for the various wrenches, screw-drivers and gauges furnished with the machine.

The molds are kept in two sliding trays at the top of the cabinet; each holds six molds in such a way that it is impossible for them to strike. Beneath these trays are two shelves for normal wedges; each shelf holds fifteen wedges and each wedge has its particular place where it is protected from injury. Two additional shelves provide for twenty-eight matrix cases; each case being held on edge and prevented from striking the other cases. Beneath these shelves are four drawers for individual matrices; each drawer is divided in thirty-seven grooves, in which the matrices are stood on end. A bar across the center of each drawer divides it so that matrices taken from the matrix case, in making changes, are put above the bar in the same groove from which the matrices below the bar are taken to replace those removed from the matrix case.

Height, 25½ inches; width, 14 inches; depth, 16 inches; shipping weight, 75 pounds. List price. \$22.00



New Departure Cabinet No. 68

NEW DEPARTURE CABINET

No. 68

A cabinet of standard dimensions, containing 50 regular full size California job cases in two tiers, 25 cases in each tier. This cabinet occupies floor space 21 x 69½ inches; height, 43 inches. Shipping weight, 600 pounds. List price. \$74.00

Without top equipment.

Prices and specifications of other New Departure Cabinets will be found on page 303.



Four Leg Imposing Frame with One Drawer

IMPOSING STONES AND SQUARE-LEG FRAMES

These Imposing Frames are substantially constructed of selected hardwoods. The coffins are of oak, and are so made that when the stone is bedded it will project 1-16 of an inch above the coffin. This ledge is to receive the galley which rests on the coffin. Type matter can be transferred from stone to galley without danger of damage. Six-leg frames have two drawers while the four-leg frames have one drawer. The frames are furnished in the white, without finish, and are shipped in knock down form, with stones crated separately.

We equip all stone frames with the finest grade of Vermont marble, the best stone imposing surface in the world. The weight of imposing stones in the standard thickness of 2 inches is approximately 30 pounds per square foot, uncrated, and 37 pounds crated.

All imposing stones are shipped *released*, and no claim can be entered for damage in transit.

PRICE LIST AND DIMENSIONS OF IMPOSING STONES AND SQUARE LEG FRAMES

	Capacity of Stone	Size of Stone	Weight of Stone	Price of Stone	Floor Space	Height	Weight of Frame	No. of Legs	Price of Frame
No. 60	2 pages, 6 Column ...	24 x 36 Ins.	210 lbs.	\$ 6.00	26½ x 38½ Ins.	38½ Ins.	130 lbs.	4	\$ 7.25
No. 61	2 pages, 7 Column ...	26 x 44 Ins.	280 lbs.	8.00	28½ x 46½ Ins.	38½ Ins.	140 lbs.	4	8.00
No. 62	2 pages, 8 Column ...	28 x 50 Ins.	350 lbs.	10.00	30½ x 52½ Ins.	38½ Ins.	160 lbs.	4	9.00
No. 63	For Job Work.....	36 x 48 Ins.	420 lbs.	12.00	38½ x 50½ Ins.	38½ Ins.	190 lbs.	4	9.50
No. 64	2 pages, 9 Column ...	32 x 60 Ins.	470 lbs.	13.50	34½ x 62½ Ins.	38½ Ins.	200 lbs.	4	10.00
No. 65	4 pages, 7 Column ...	26 x 76 Ins.	475 lbs.	13.75	28½ x 78½ Ins.	38½ Ins.	200 lbs.	6	10.75
No. 66	4 pages, 8 Column ...	28 x 80 Ins.	530 lbs.	15.50	30½ x 82½ Ins.	38½ Ins.	270 lbs.	6	12.50
No. 67	4 pages, 9 Column ...	30 x 90 Ins.	650 lbs.	18.75	32½ x 92½ Ins.	38½ Ins.	290 lbs.	6	14.50
No. 68	4 pages, 6 Col. Quarto	36 x 60 Ins.	525 lbs.	15.00	38½ x 62½ Ins.	38½ Ins.	200 lbs.	4	12.00
No. 69	4 pages, 7 Col. Quarto	48 x 60 Ins.	675 lbs.	20.00	50½ x 62½ Ins.	38½ Ins.	225 lbs.	4	15.00

HAMILTON CORRECTING BANK

Compact in form without waste space. Three men can work at it without interfering. It holds 126 loaded galleys.

Above the top is a lead rack, subdivided into 36 divisions, which will accommodate 13-em leads and slugs. Immediately under the lead rack is an opening extending to a metal-lined chute through which the discarded slugs drop to the truck below.

Dimensions—Floor space, 25½ x 59 inches; height at the front and ends, 44½ inches; total height to top of lead rack, 57½ inches. There are six tiers of galley racks, each tier accommodating 21 standard linotype galleys 24 inches long. These galley shelves are 5 inches wide inside. The two shelves over the truck are 20 inches wide and 18½ inches deep. The drawer under the top is 17 x 18½ inches inside. The metal box of truck is 13 inches wide, 19 inches long and 16½ inches deep, tapered with round bottom.

LIST PRICES

With wood top, without truck\$ 90.00
 With full brass lined top, without truck 110.00
 Metal lined dumping truck..... 40.00



Hamilton Correcting Bank with Truck

THE H. C. HANSEN TYPE FOUNDRY

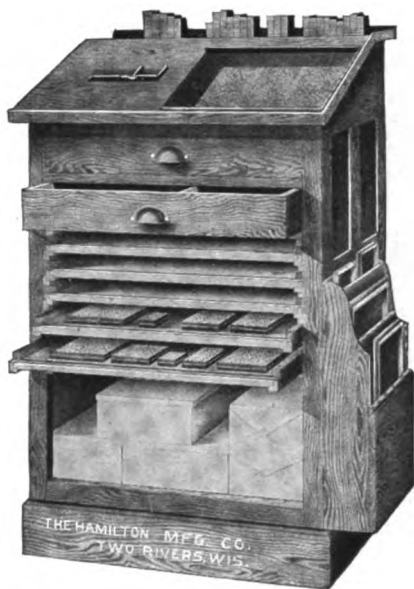

Dorsey Compositor's Working Cabinet

DORSEY COMPOSITOR'S WORKING CABINET

Patented

A time saver and money maker

Sloping top is same size as ordinary lower case. 8-inch flat surface at top for slugs, etc. Two drawers each with two compartments for copy, tools, etc. Five letter boards each 21½ x 24 inches inside. Galley rack at side accommodates four brass galleys. Under letter boards is large open space for storage of cuts, personal property of compositor, etc.

List Price, \$36.00



Dorsey Combination Press Room Cabinet

DORSEY COMBINATION PRESS ROOM CABINET

Patented

It will clear up the office and reduce danger from fire. The top is covered with plate glass, substituting the old ink slab. Beneath the glass are receptacles for inks, oil cans, tympan paper, etc. Beneath this is a drawer 3½ inches deep for wrenches, etc. Beneath this drawer is a compartment for scraps of paper, spoiled sheets, etc. The material is thrown through a V-shape open bin on opposite side from which drawer pulls so it is not necessary to open drawer to put material into it. Below this drawer is a metal-lined compartment for old rags, accessible from both sides of cabinet. List Price, \$36.00

MEDORA LEAD AND SLUG BANK

Substantially and conveniently arranged, it occupies very small floor space, but possesses tremendous storage capacity.

The Lead Bank arranged on both sides of the cabinet at an angle of 45 degrees, has compartments on each side, in duplicate, to take lengths from 4 to 25 picas, varying by single ems, allowing leads and slugs to be kept separate. The length of lead bank is five feet, and width is 32 inches on each side of cabinet. By stacking leads two tiers deep it gives 53 square feet of lead and slug surface, while floor space occupied by cabinet is about 17 square feet.

Six Letter Boards or Metal Furniture Drawers under the lead and slug bank, pulling from both ends, and enclosed by drop doors. These drawers are all five feet long.

There are 36 Sort drawers, 9 drawers in tier, two tiers on each side of the cabinet at the ends. Each drawer is subdivided into ten equal compartments, each compartment 3¼ x 3¼ x 2½ inches, inside measure.

The Letter Boards—11 on each side—flipped in front to receive galleys, provide 88½ square feet of storage surface for tied-up forms and standing matter. The size of letter boards is 30½ x 19 inches inside. List Price, Complete, \$145.00

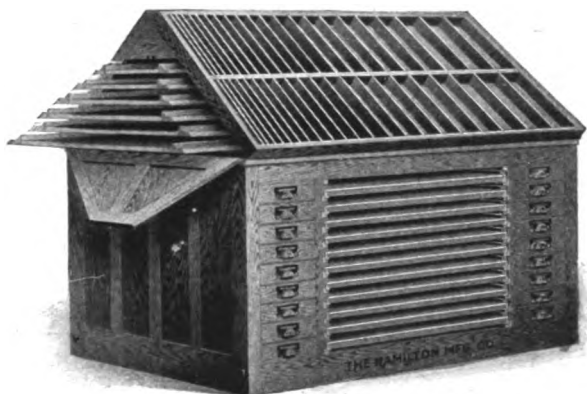

Medora Lead and Slug Bank

PROOF READER'S DESK No. 1

Properly constructed to meet the requirements of modern proof readers. Made of hardwood, nicely finished. Designed from suggestions furnished by practical proof readers. Length 37½ inches, depth 18 inches, height to flat top 31 inches, to top of hood 42 inches.

List Price, \$20.00



Proof Reader's Desk No. 1

THE H. C. HANSEN TYPE FOUNDRY



LABOR-SAVING FURNITURE CASES

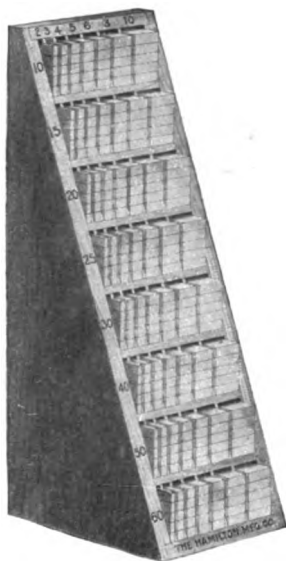

No. 10 Midget Furniture Case

Built in the most convenient form without door, and with partitions separating the various widths and lengths.

All furniture which goes into these cases is cut from carefully selected stock, thoroughly seasoned and oil-soaked. With the aid of our special machinery, we are enabled to produce furniture which is smoothly finished, accurate and uniform in size.

The lengths are stamped on the ends of the pieces of all of our furniture.

The lengths and widths are also placed on the edges of the case, as shown in the illustration. This feature assists in the distribution and replacing of the furniture in the cases after use.

A line gauge for determining lengths is placed on the edge of each furniture case, numbered by picas, making distribution easy.

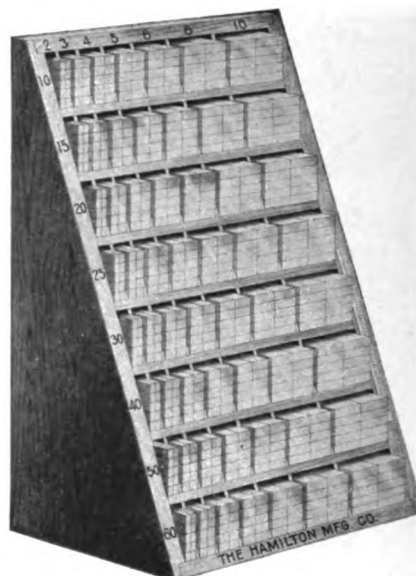

No. 12 Standard Furniture Case

LIST PRICES, DIMENSIONS AND WEIGHTS OF ALL FURNITURE CASES

No.	Name	Pica Lengths	No. of Pieces	Height Inches	Dimensions of Base	Case and Furniture	Weight Crated	Furniture Only	Weight Boxed
10	Midget.....	10 to 60	280	31	10 x 10½	\$ 6.00	50	\$ 2.75	25
11	Midget Extension.....	70 to 160	245	28	10 x 27½	17.00	130	8.25	70
12	Standard.....	10 to 60	560	31	16½ x 10½	10.00	80	5.00	50
13	Standard Extension.....	70 to 160	490	28	16½ x 27½	23.00	190	15.50	140
14	Double Standard.....	10 to 60	1,176	41½	22½ x 10½	20.00	175	11.50	100
15	Double Standard Extension.....	70 to 160	1,029	34½	22½ x 27½	45.75	375	33.75	275
16	Baby Mammoth.....	10 to 160	765	41	18½ x 27½	29.00	240	15.00	136
17	Mammoth.....	10 to 170	1,530	41	31½ x 27½	40.00	400	25.00	230
18	Variety.....	12 to 120	1,112	24½	30 x 21	24.75	190	13.75	100
19	Caslon.....	12 to 120	2,080	39½	30 x 21	46.50	340	26.00	200
20	Jumbo.....	12 to 216	3,800	62	31 x 37	110.00	760	73.00	500

Order by name and number.

The feature of extension furniture cases is entirely new and such cases are here listed for the first time. Many printers have found that the lengths which usually go with an ordinary furniture case are not long enough for all requirements. Thus it has been necessary to make special cases to meet the requirements and often the old case has been found useless after the new case was installed. With the extension furniture cases a printer requiring longer lengths can order the companion case to the one he already has and the two will work together. The case with the shorter lengths can be set on top of the one with longest lengths. The two cases combined make practically one complete furniture case.

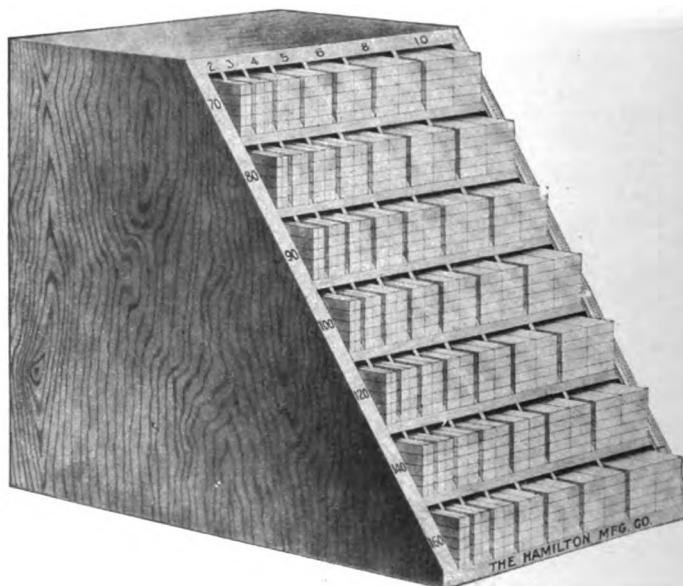

No. 15 Standard Extension Furniture Case

THE H. C. HANSEN TYPE FOUNDRY

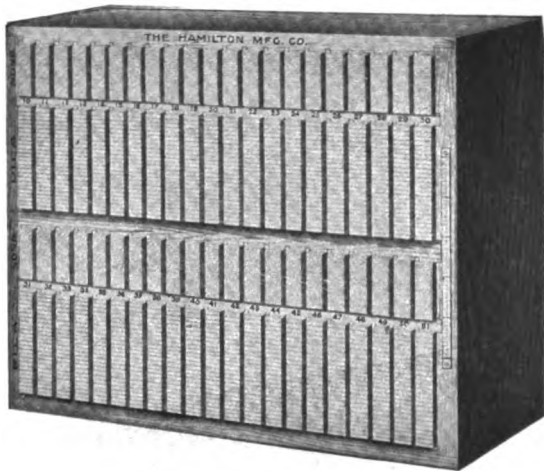

Labor-Saving Reglet Case No. 5

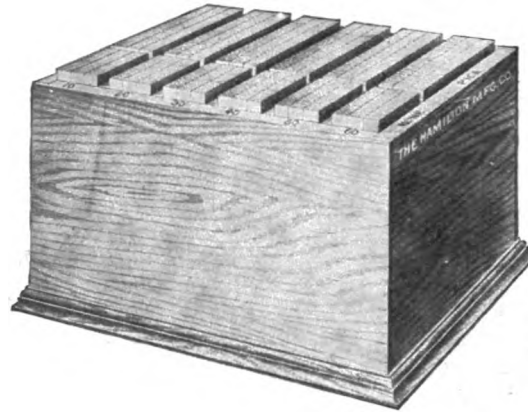

Labor-Saving Reglet Case No. 1

LABOR-SAVING REGLET CASES

The cases are made of selected hardwood and finished in antique oak, of fine appearance and substantial build. The reglet is made of thoroughly oiled hardwood, accurately cut and trimmed to even points, and guaranteed to give satisfaction.

LIST PRICES OF ALL REGLET CASES

Description	Case and Reglet	Reglet only
No. 1 contains 300 yards, cut into 1,800 pieces, 10 to 60 picas.....	\$10.00	\$ 6.00
No. 2 contains 560 yards, cut into 2,400 pieces, 10 to 120 picas.....	18.00	12.00
No. 3 contains 600 yards, cut into 4,200 pieces, 10 to 51 picas.....	18.00	11.00
No. 4 contains 300 yards, cut into 2,100 pieces, 10 to 51 picas.....	11.00	5.50
No. 5 contains 1,550 yards, cut into 6,200 pieces, 10 to 150 picas.....	45.00	30.00
No. 6 contains 775 yards, cut into 3,100 pieces, 10 to 150 picas.....	27.00	15.00

HANDY LETTER BOARD CABINETS

For job work these small letter board cabinets are unrivaled. Nos. 25, 26 and 27, in single tier, occupy floor space of 16½ x 19 inches, and are filled with letter boards, 12 x 15 inches inside, constructed of hardwood throughout.

The sides of the cabinet are tastefully paneled and all exterior surfaces are finished and varnished like the best type cabinets.

The letter boards are lipped in front to receive the galleys and have retaining walls at the ends and back to hold the type forms.

- No. 25. 10 Letter Boards.....List price \$14.50
- No. 26. 12 Letter Boards.....List price 17.00
- No. 27. 16 Letter Boards.....List price 21.00

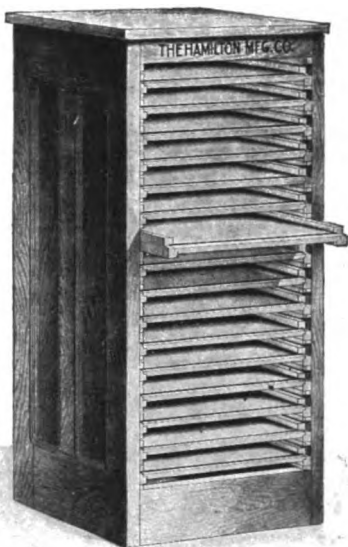

No. 27 Handy Letter Board Cabinet

WOOD FURNITURE AND REGLET

	Softwood	Hardwood		Hardwood
6-Pt., per yd.....	\$0.01½	\$0.02	48-Pt., per yd. (4-line).....	\$0.04
8-Pt., " "01½	.02	60-Pt., " " (5-line).....	.04
10-Pt., " "01½	.02	72-Pt., " " (6-line).....	.06
12-Pt., " "01½	.02	96-Pt., " " (8-line).....	.06
18-Pt., " "02	.03	120-Pt., " " (10-line).....	.08
24-Pt., " " (2-line) .	.02½	.03	144-Pt., " " (12-line).....	.08
36-Pt., " " (3-line) .		.04	216-Pt., " " (18-line).....	.12

BEVELED SIDE STICKS

Extra thin.	Thick end ½ inch, thin end ⅜ inch, per yard.....	\$0.04
Thin	Thick end ¾ inch, thin end ½ inch, per yard.....	.05
Medium	Thick end 1 inch, thin end ¾ inch, per yard.....	.06
Thick	Thick end 1½ inch, thin end 1 inch, per yard.....	.07

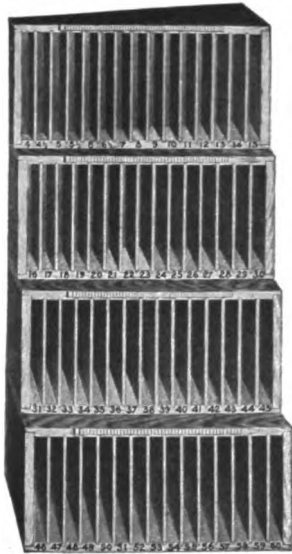

Boston Lead Rack

BOSTON LEAD RACK

This rack is made in four sections, which are sold separately, if desired. The different lengths which go in each section are stamped at the bottom of each compartment, as shown in cut. A line gauge is attached to each section. The four sections accommodate the lengths from 4 to 7 varying by ems, and from 7 to 60, varying by ems.

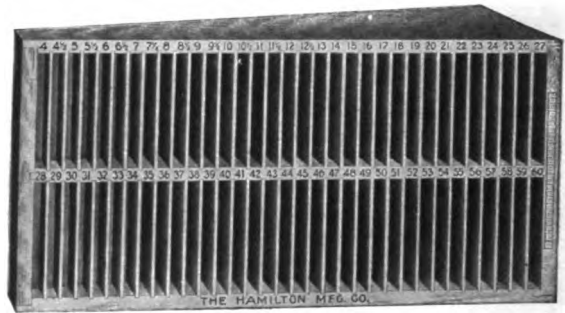

Two-Tier Wisconsin Lead Rack

WISCONSIN LEAD RACK

A common-sense rack and one in which leads will not pl. These are made in a superior solid style, and each compartment is numbered very plainly. A line gauge is attached to every lead rack. The two-tier rack will hold 750 pounds of leads and slugs; the four-tier rack will hold 1,500 pounds.



Eureka Lead Rack

EUREKA LEAD RACK

Substantially constructed in two sections, each section holding lengths from 4 to 28 ems, varying by single ems. One section may be used for leads and the other for slugs. The partitions in this rack are placed on an incline to prevent the leads and slugs from falling. These partitions are also inclined backwards, so that the material cannot be easily thrown from the case by a slight jar.

LIST PRICES OF LEAD AND SLUG RACKS

Description	Price of Rack only	Reglet to Fill
Two-tier Wisconsin Rack.....	\$6.00	\$14.00
Four-tier Wisconsin Rack.....	9.00	28.00
Eureka Lead Rack.....	2.50	4.25
Boston Rack No. 1, 4 to 15 ems } Price {	.90	.80
Boston Rack No. 2, 16 to 30 ems } set of {	1.20	1.80
Boston Rack No. 3, 31 to 45 ems } four {	1.50	3.00
Boston Rack No. 4, 46 to 60 ems } \$5.40 {	1.80	4.25

SPACE RULE CASE

Designed to take standard fonts of space rule, as now put up by the manufacturers. Made in three sections, each section taking a one pound font in any size from 1 point to 12 points. Three one pound fonts of any one size or three separate fonts of three different sizes will just fill the case. See cut below. List price, 50 cents.



Space Rule Case

HAMILTON LEADER BOX

The Hamilton box is one of the best, as it can be used anywhere about the office, carried to the job bank or used on a stone.

Size, 5 x 8 x 1 1/4 inches.
List price..... \$0.25
Per dozen..... 2.50

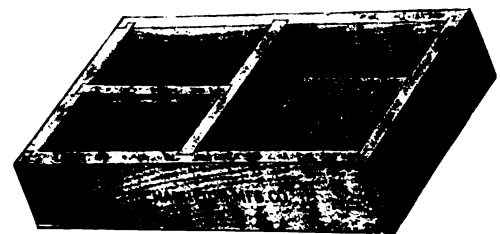

Hamilton Leader Box



METROPOLITAN IMPOSING STONE FRAME

WITH DUSTLESS BOTTOM



Metropolitan Imposing Stone Frame with Dustless Bottom

of 206 yards selected oil soaked hardwood Furniture, 1155 pieces, and pica Reglet cut on the point system, smooth and perfect with variations by single picas in the shorter lengths, and by three picas in the longer lengths, a total of 280 yards, 2016 pieces.

Size of Stone 48 x 72 inches. Height from floor to top of stone, 38 inches. The frame occupies a floor space of 50½ x 74½ inches. Weight, complete, with Stone and full equipment of Reglet and Furniture, 2250 pounds. Weight, complete, without Stone, 1360 pounds.

Fitted with Letter Boards, Galley Racks, Chase Racks, Reglet and Furniture Racks, Drawers for metal furniture, etc.

There are 24 Letter Boards, 23½ x 30½ inches inside, 12 on each side of frame, supported on heavy steel runs. Under coffin are 2 Drawers 14 x 48½ inches, 3 inches deep, and 2 drawers 14 x 48½ inches, 1 inch deep, for metal furniture. 6 Chase Racks on one side, vertical clearance, 25½ inches, measurement from front to back 32½ inches. On the other side are two series of 6 Chase Racks, measuring vertically 14 inches and 11 inches, both 17½ inches from front to back. All Chase Racks metal lined on bottom to prevent injury to woodwork. One tier of Galley Racks on each side, each having 14 shelves for double column galleys. There is a total

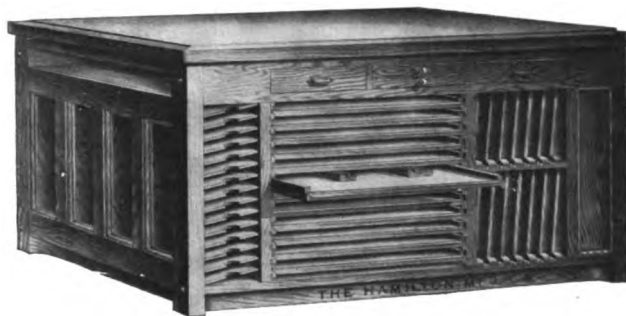

Metropolitan Imposing Stone Frame. Opposite Side of Cut Shown Above

List Price, complete, with Stone.....\$195.00

PRESSMAN'S REGISTER CABINETS

The top is of heavy plate glass, with compartment under glass finished in white enamel. The light reflectors in the bottom of this compartment are turned upward, thus throwing a strong white light which is reflected through the sheets when laid on the plate glass to determine the register. These cabinets are made of hardwood, and with the exception of the interior light-compartment, are finished the same as all our other cabinet work.

PRESSMAN'S REGISTER CABINET No. 1

Occupies floor space 30 x 44 inches; height from floor to plate glass, 32 inches; size of plate glass top 28½ x 42½ inches; thickness of glass ½ inch. Three lights are fitted in the light-compartment, in triangular form, wired and complete with reflectors. This light-compartment is finished in white enamel. Top is removable, thus providing access to light-compartment. Shipping weight, 325 pounds. List Price,.....\$50.00



Pressman's Register Cabinet No. 1

PRESSMAN'S REGISTER CABINET No. 2

Has top like the No. 1 Cabinet, but has base containing four drawers 17½ x 26 x 3½ inches inside, and one drawer 36 x 26 x 3½ inches inside. Access to light compartment is provided by sliding doors on each side. Occupies floor space 32 x 46 inches. List Price.....\$80.00

THE H. C. HANSEN TYPE FOUNDRY



MALLETS, PLANERS, ETC.

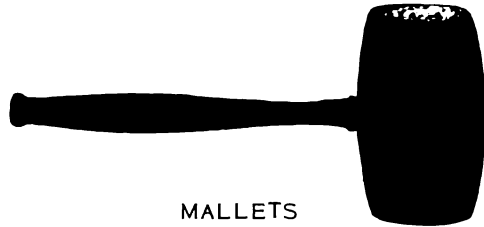

MALLETS

Made of thoroughly seasoned and selected stock, handles screwed in, finished in oil, attractive shape. Our Lignumvitæ Mallets are specially recommended. They are heavier than Hickory Mallets and wear like iron.

No. 1—Hickory, small,	2½ x 4½ inches	wt. 10 oz.	\$0.25
No. 2—Hickory, medium,	3 x 5 inches	" 1 lb.	.30
No. 3—Hickory, large,	3½ x 6 inches	" 1½ lbs.	.40
No. 4—Lignumvitæ,	1½ x 2½ inches	" 5 oz.	.30
No. 5—Lignumvitæ,	1¾ x 3 inches	" 7 oz.	.40
No. 6—Lignumvitæ,	2½ x 3½ inches	" 10 oz.	.50
No. 7—Lignumvitæ,	3 x 5 inches	" 1½ lbs.	.60
No. 8—Lignumvitæ,	3½ x 5½ inches	" 2½ lbs.	.75
No. 9—Iron bound		" 1½ lbs.	1.00

Weight Approximate



RAWHIDE MALLETS

The head of this mallet is made of specially treated rawhide, formed into shape by hydraulic pressure, and kept in shape by waterproof adhesives. It is the most serviceable mallet made for printers' use.



No. 4, 2 x 3½ in.,	weight 10 oz.	\$0.75
No. 5, 2½ x 4½ in.	" 21 oz.	1.50
No. 10, 2 x 3½ in.	" 24 oz.,	
	loaded with lead	.90

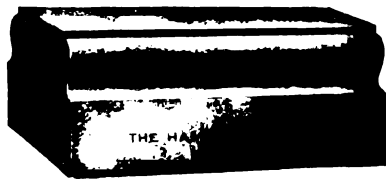

PLANERS

Our planers are made of the best selected and seasoned rock maple, which will hold its surface longer than cheaper woods and gives perfect satisfaction.

Maple, 3½ x 6 inches,	weight 1½ lbs.	\$0.25	
Maple, 3½ x 8 inches,	weight 1¾ lbs.	.30	
Maple, leather top,	3½ x 8 inches,	weight 2 lbs.	.40
Midget planers,	1½ x 3 x 1½ inches,	weight 3 ounces.	.07



PROOF PLANERS

Made of maple, carefully faced with high-priced closely woven, firm and durable felt.

Size 3½ x 8 inches,	weight 2 lbs.	\$0.60	
Size 3½ x 8 inches,	with leather top,	weight 2 lbs.	.70

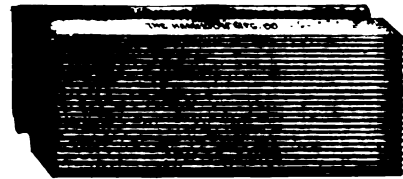

LINOTYPE PLANER

A necessity in every office having linotype machines. Faced with corrugated rubber, it removes the "whiskers" from linotype slugs without injuring the face of the type.

Size 3½ x 6 inches,	weight 1½ lbs.	\$0.50
---------------------	----------------	--------

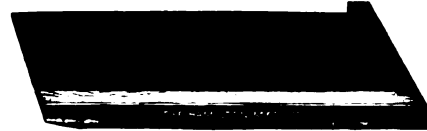

WOOD GALLEYS

Made of hard wood throughout, of the best seasoned stock. The bottoms are screwed to the rims, the open end is rounded to a sharp edge. The rim extends around one side and one edge only.

4 x 6....	\$0.20	6½ x 24....	\$0.60	10 x 16....	\$0.65
5 x 8....	.25	6 x 20....	.50	9 x 18....	.70
5 x 15....	.30	7 x 22....	.55	10 x 24....	.75
5½ x 18....	.40	8 x 10....	.40	3½ x 24....	.50
6 x 10....	.30	8 x 24....	.60		



BRONZING PAD

Bronze is placed in top and is delivered through valves in center of fur at bottom, passing through a sieve before reaching the paper. The quantity of bronze required can be regulated by screw at end of pad. No bronze can escape except through the bottom. Absolutely no waste of bronze.

Large size, 2½ x 6 inches	\$2.50
Small size, 2½ inches square	1.50



WOOD TYPE

The wood type shown in this catalog is cut on solid end grain Wisconsin Rock Maple which is absolutely the hardest of American woods. By the use of recently perfected special machinery the makers are enabled to produce wood type guaranteed to be accurate in height within one-thousandth of an inch. Wood type of guaranteed height has not heretofore been obtainable.

All designs can be furnished in any size desired although space allows us to show only a few styles and sizes.

The prices for all sizes of any style can be found by referring to the accompanying price list. The left hand column gives the size of type, or lines pica; the letters, L, M, N, etc., at the top of the table, give the class to which the style belongs, and the figures in the different columns give the prices for the different sizes up to 100 lines pica.

To find the net cost of any style of type in any size desired, by the use of the two scales: first determine the kind of font desired—whether caps only, or caps and figures, or caps, lower case and figures. Then determine the size of font desired, whether 3A, 4A, or 5A. When this is determined you will have the total number of characters in the font. See in what class the particular style is listed and find the price per letter. Multiply the total number of pieces by this price per letter and deduct the discount and you have the net price.

REVISED PRICE LIST										
Lines Pica	Class L	Class M	Class N	Class O	Class P	Class Q	Class R	Class S	Class T	Class U
	Cents per Letter	Cents per Letter	Cents per Letter	Cents per Letter	Cents per Letter	Cents per Letter	Cents per Letter	Cents per Letter	Cents per Letter	Cents per Letter
2	6	6	6	6	6	6	8	10	13	16
3	6	6	6	6	6	6	8	12	15	18
4	6	6	6	6	6	6	8	12	15	18
5	6	6	6	6	6	7	8	9	14	20
6	6	6	6	6	6	8	10	11	16	22
8	8	8	8	8	10	12	13	18	22	26
10	9	9	10	10	12	15	16	20	25	30
12	10	10	12	12	14	17	18	23	28	32
14	11	12	13	14	16	20	22	26	30	34
15	12	13	14	15	18	21	24	28	32	36
16	12	14	15	16	19	22	25	30	34	38
18	13	15	17	18	21	24	28	33	37	42
20	14	16	18	20	24	28	32	37	40	44
24	17	19	22	24	28	32	36	42	45	48
25	18	20	23	25	30	34	38	45	48	50
30	21	24	28	30	35	40	44	52	55	58
35	28	31	34	36	41	46	50	56	59	62
40	33	36	38	40	45	50	56	60	63	66
45	36	39	42	45	50	58	63	64	67	70
50	45	47	48	50	56	65	70	70	72	74
60	50	53	56	60	66			80	83	86
72	60	62	64	72	78			90	95	100
80	64	66	68	80	86			100	107	114
100	75	78	80	100	106			115	125	135

SCALE OF FONTS											
Showing number of letters in each font from 3a to 5a											
3 A		3 a		4 A		4 a		5 A		5 a	
Caps	L. Case	Caps	L. Case	Caps	L. Case	Caps	L. Case	Caps	L. Case	L. Case	
75	65	106	90	120	104						
Letters		Letters		Letters		Letters		Letters		Letters	
A	-3	a	-3	A	-4	a	-4	A	-5	a	-5
B	-2	b	-2	B	-3	b	-3	B	-3	b	-3
C	-2	c	-2	C	-3	c	-3	C	-4	c	-4
D	-2	d	-2	D	-3	d	-3	D	-4	d	-4
E	-4	e	-4	E	-5	e	-5	E	-6	e	-6
F	-2	f	-2	F	-3	f	-3	F	-3	f	-3
G	-2	g	-2	G	-3	g	-3	G	-4	g	-4
H	-2	h	-2	H	-3	h	-3	H	-4	h	-4
I	-4	i	-3	I	-4	i	-4	I	-5	i	-5
J	-2	j	-1	J	-3	j	-2	J	-3	j	-2
K	-1	k	-1	K	-2	k	-2	K	-2	k	-2
L	-3	l	-4	L	-5	l	-5	L	-6	l	-6
M	-2	m	-2	M	-3	m	-3	M	-4	m	-4
N	-3	n	-3	N	-4	n	-4	N	-5	n	-5
O	-3	o	-3	O	-4	o	-4	O	-3	o	-3
P	-2	p	-2	P	-3	p	-3	P	-3	p	-3
Q	-1	q	-1	Q	-2	q	-2	Q	-2	q	-2
R	-3	r	-3	R	-4	r	-4	R	-5	r	-5
S	-4	s	-4	S	-5	s	-5	S	-6	s	-6
T	-3	t	-4	T	-4	t	-4	T	-5	t	-5
U	-2	u	-2	U	-3	u	-3	U	-4	u	-4
V	-2	v	-2	V	-3	v	-3	V	-3	v	-3
W	-2	w	-2	W	-3	w	-3	W	-3	w	-3
X	-1	x	-1	X	-2	x	-2	X	-2	x	-2
Y	-2	y	-2	Y	-3	y	-3	Y	-3	y	-3
Z	-1	z	-1	Z	-2	z	-2	Z	-2	z	-2
&	-1	&	-1	&	-2	&	-1	&	-2	&	-1
!	-2	!	-1	!	-3	!	-1	!	-1	!	-1
;	-1	;	-1	;	-1	;	-1	;	-1	;	-1
,	-3	,	-1	,	-4	,	-1	,	-4	,	-1
.	-1	.	-1	.	-2	.	-1	.	-2	.	-1
'	-1	'	-1	'	-1	'	-1	'	-1	'	-1
'	-2	'	-1	'	-2	'	-1	'	-2	'	-1
'	-3	'	-1	'	-4	'	-1	'	-4	'	-1
?	-1	?	-1	?	-1	?	-1	?	-1	?	-1

Figures 1 2 3 4 5 6 7 8 9 0 \$ } 26 in each
No. of each 3 2 2 2 2 2 2 2 2 5 2 } font

Larger fonts put up 7A, 9A, 12A, 15A, 20A, 30A and 7a, 9a, 12a, 15a, 20a, 30a can be furnished.

Give full directions for shipping unless it is desired to leave the matter to us, in which case we will ship the cheapest way, by freight or express.

THE H. C. HANSEN TYPE FOUNDRY

190-192 CONGRESS STREET, BOSTON

Established 1872

43 CENTRE STREET, NEW YORK

THE H. C. HANSEN TYPE FOUNDRY



WOOD TYPE

No. 4006—Class L

Six Line

6c per Letter

DELIGHTFUL Homes 3

No. 4006—Class L

Eight Line

8c per Letter

ROUGH RIDING 2

No. 4006—Class L

Ten Line

9c per Letter

DESIGNED 5

No. 4006—Class L

Twelve Line

10c per Letter

RED BAND

All Styles of Wood Type shown in this book made in any size desired—caps, lower case and figures
For prices and font schemes see page 315

THE H. C. HANSEN TYPE FOUNDRY

WOOD TYPE

No. 5072—Class O

Ten Line

10c per Letter

KIND 2

No. 6243—Class L

Eight Line

8c per Letter

BLUE Robes 2

No. 3164—Class N

Ten Line

10c per Letter

BINDERS

No. 689—Class N

Ten Line

10c per Letter

STUMP 2

All Styles of Wood Type shown in this book made in any size desired—caps, lower case and figures
For prices and font schemes see page 315

THE H. C. HANSEN TYPE FOUNDRY

WOOD TYPE

No. 180—Class N

Ten Line

10c. per Letter

HORSE RACES

68

No. 3161—Class P

Six Line

8c per Letter

MOUND

5

No. 627—Class O

Eight Line

8c per Letter

Nurse 13

No. 627—Class O

Twelve Line

12c per Letter

SIGN

All Styles of Wood Type shown in this book made in any size desired—caps, lower case and figures
For prices and font schemes see page 315

THE H. C. HANSEN TYPE FOUNDRY

WOOD TYPE

No. 5009—Class N

Four Line

6c per Letter

PINK Roses 123

No. 180—Class N

Five Line

6c per Letter

Beautiful Roses in Gardens 9523

No. 660—Class N

Twelve Line

12c per Letter

MARKET Value

No. 641—Class P

Eight Line

10c per Letter

Show Cards 8

All Styles of Wood Type shown in this book made in any size desired—caps, lower case and figures
For prices and font schemes see page 315

THE H. C. HANSEN TYPE FOUNDRY

WOOD TYPE

No. 679—Class N

Five Line

6c per Letter

Honor Our Friends 65

No. 679—Class N

Twelve Line

12c per Letter

KINGDOM

No. 706—Class N

Five Line

6c per Letter

San Francisco 25

No. 706—Class N

Fifteen Line

14c per Letter

GEMS

All Styles of Wood Type shown in this book made in any size desired—caps, lower case and figures
For prices and font schemes see page 315

THE H. C. HANSEN TYPE FOUNDRY



WOOD TYPE

No. 172—Class N

Four Line

6c per Letter

BOUNDING Wave 2

No. 665—Class O

Eight Line

8c per Letter

ROGUES 2

No. 105—Class N

Eight Line

8c per Letter

ROSEBUDS 2

No. 5041—Class O

Fifteen Line

15c per Letter

R I G

All Styles of Wood Type shown in this book made in any size desired—caps, lower case and figures
For prices and font schemes see page 315

THE H. C. HANSEN TYPE FOUNDRY



WOOD TYPE

No. 4056—Class N

Six Line

6c per Letter

BEAUTIFUL AFRICAN DIAMONDS 263

No. 235—Class P

Six Line

8c per Letter

RICE Bed 15

No. 699—Class P

Six Line

8c per Letter

ON Sea 13

No. 226—Class S

Six Line

16c per Letter

World's Fair 2

No. 255—Class N

Twelve Line

12c per Letter

GRINDERS

All Styles of Wood Type shown in this book made in any size desired—caps, lower case and figures
For prices and font schemes see page 315

THE H. C. HANSEN TYPE FOUNDRY



SILHOUETTES AND CATCHWORDS

MADE ANY SIZE DESIRED



No. 28 8-Line



No. 34 8-Line

PRICES OF SILHOUETTES

12-Line, each.....\$0.75	30-Line, each.....\$1.75
15-Line, each......85	36-Line, each..... 2.00
18-Line, each..... 1.00	40-Line, each..... 2.25
20-Line, each..... 1.25	50-Line, each..... 2.50
24-Line, each..... 1.50	60-Line, each..... 3.00

PRICES OF CATCHWORDS

5-Line, each.....\$0.20	18-Line, each.....\$0.50
6-Line, each......20	20-Line, each......50
8-Line, each......25	25-Line, each......75
12-Line, each......40	30-Line, each......75
15-Line, each......40	40-Line, each..... 1.00



No. 31 8-Line



No. 29 8-Line

WOOD RULE BORDERS

Sidewood, yard lengths, per yard.....\$0.12
 Endwood, cut in labor-saving lengths, per foot......15
 Solid corners, any rule, endwood or sidewood, set of four .25

Style N. 8-Point



Style P. 10-Point



Style R. 12-Point



Style U. 18-Point



Style W. 24-Point



Style Y. 36-Point



Style E. 12-Point



Style J. 24-Point



No. 31 8-Line



No. 44 18-Line



No. 45 18-Line



No. 51 12-Line



No. 29 5-Line



No. 56 12-Line



No. 17 5-Line



No. 55 12-Line

THE H. C. HANSEN TYPE FOUNDRY



WOOD BORDERS AND ORNAMENTS

Five Line Border No. 448

Per foot \$1.05



Three Line Border No. 448

Per foot \$0.85



Other Sizes Border 448

2=Line, per foot \$0.75
9=Line, per foot 1.50

6=Line, per foot \$1.20
10=Line, per foot 1.60

7=Line, per foot \$1.30

8=Line, per foot \$1.40
Corners, per set, same price as border per foot

Four Line Border No. 448

Per foot \$0.95

No. 92 4=Line

No. 89 4=Line



FANCY ORNAMENTS—Made any size desired

4=Line, per pair \$0.50 5=Line, per pair \$0.50 6=Line, per pair \$0.60 8=Line, per pair \$0.75 10=Line, per pair \$1.00
12=Line, per pair \$1.00 15=Line, per pair \$1.25 18=Line, per pair \$1.50 20=Line, per pair \$1.50

No. 157 10=Line

No. 132 6=Line

No. 9 12=Line

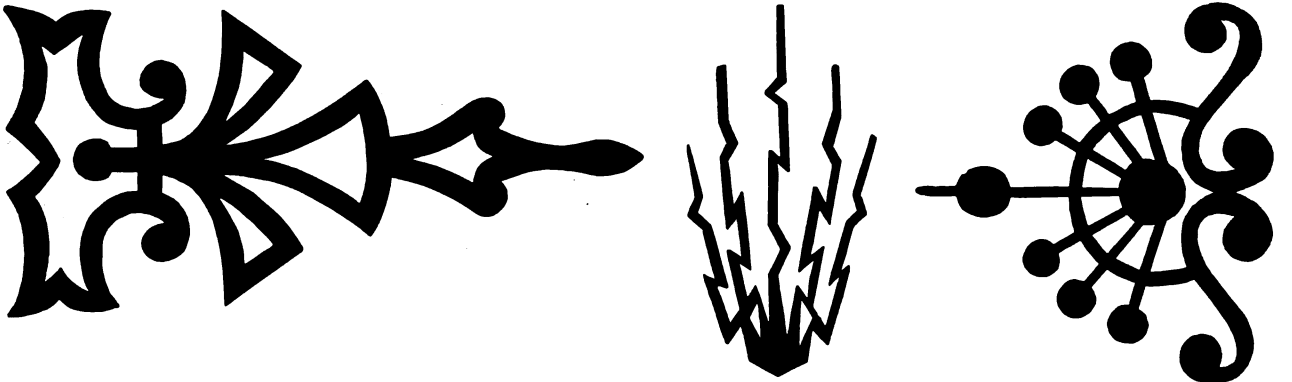

No. 7 6=Line

No. 7 6=Line

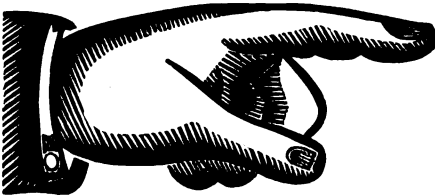

INDEXES—Made any size desired

PRICE PER PAIR

5=Line.. \$2.00	12=Line.. \$3.00
6=Line.. 2.00	15=Line.. 3.25
8=Line.. 2.25	20=Line.. 3.50
10=Line.. 2.50	30=Line.. 4.00
40=Line... \$6.00	

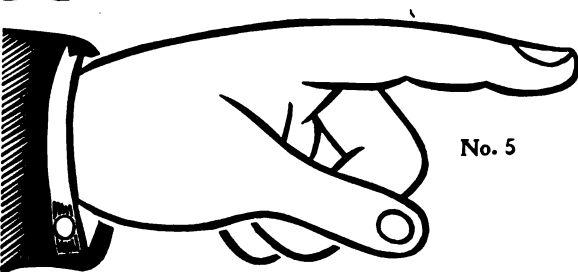

No. 5

8=Line



No. 5

THE H. C. HANSEN TYPE FOUNDRY



END WOOD BORDERS

TWELVE FEET OF BORDER AND ONE SET OF CORNERS REQUIRED FOR A FULL SHEET OF 25x38 INCHES

Border No. 263 Per foot 60c



Border No. 265 Per foot 60c



Border No. 269 Per foot 60c



Border No. 130 Per foot 60c



Border No. 256 Per foot 60c



Border No. 263 Per foot 60c



Border No. 110 Per foot 70c



Border No. 78 Per foot 70c



Border No. 132 Per foot 70c



Border No. 368 Per foot \$1.25

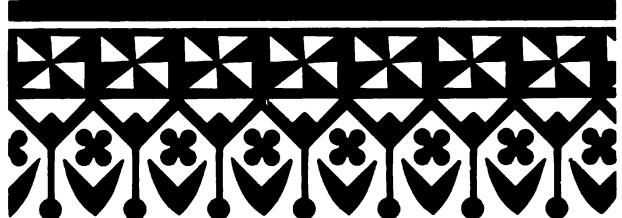

Border No. 371 Per foot \$1.25



Border No. 125 Per foot \$1.00

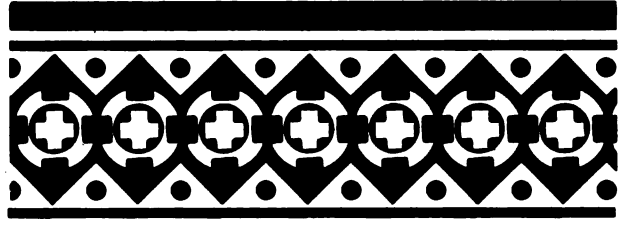

Solid Corners per Set of four pieces, same price as corresponding border per foot

STAR RULE BORDERS

Cut on the point system

Price of all sizes 30c per foot

Solid corners 40c per set of four

No. 1. 12-Point

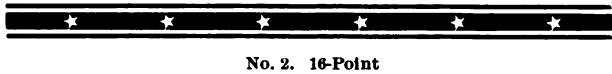

No. 2. 16-Point

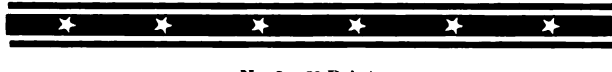

No. 3. 20-Point



No. 4. 24-Point



No. 5. 30-Point

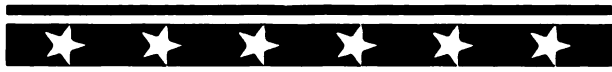

No. 6. 40-Point



No. 8. 16-Point

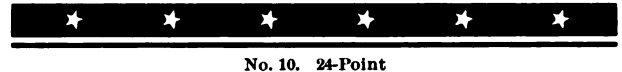

No. 10. 24-Point



No. 13. 48-Point



THE H. C. HANSEN TYPE FOUNDRY



Hansen's Complete Mitering Machine

PATENTED

Price, Complete
\$18.50

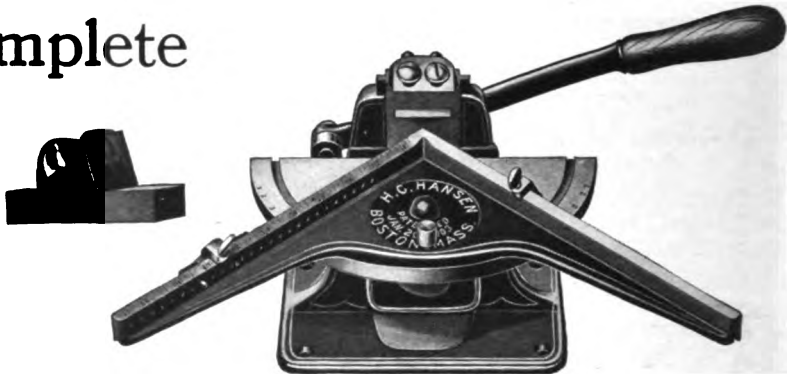

Miters any angle accurately and in much less time than any other, therefore it saves the printer from continually wasting brass rule and enables him to do better work. The rule holder has an angle of 90 degrees, when placed in the center you can miter square sets without changing its position. It is easily set by a pin for any desired angle, having no lines to guess at, the operator obtains the required angle positively accurate. It is graduated by 12-point ems and has two gauges, the left hand gauge having a supporter that enters any one of the holes of even ems and by turning the supporter each quarter turn it lengthens or shortens the measure a 6-point em. The inside measure is obtained by placing 2, 3, or 4 points between the supporter and the gauge.

The knife is held firmly by two screws and is regulated by two adjusting screws. A jointer for sharpening the knife to the proper angle is furnished with each machine. This enables the operator to always have the same bevel, which is very essential in order to obtain a clean cut.

The handle strikes a rubber tube which does away with the noise and jar received on other machines. A cup for chips is included with each machine.

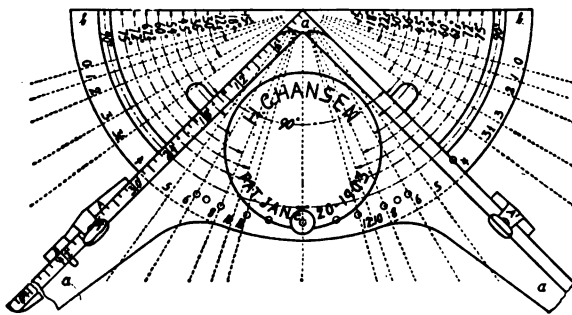

Diagram 1

To miter a square—angle 90 degrees—place the brass rule supporter *aaa* in the center of the bed *bb* on the Mitering Machine, the adjusting pin *c* in the center hole, leaving Figure 4 on the bed in view on each side of the supporter, as indicated in diagram 1. In that position each end of the rule can be mitered to 45 degrees without any change of the supporter.

When it is desired to miter any one of the designs shown in Diagram 2, take the degree from the desired design and find the corresponding degree in Diagram 1, and place the supporter on dotted line corresponding with the figure on the Mitering Machine, as indicated in Diagram 1. For instance, if you wish to miter an octagon, as indicated in Diagram 2, Figure F, each end of the rule to be mitered $67\frac{1}{2}$ degrees, place the supporter

to the right, leaving Figure 8 in view on the mitering machine, and miter the first ends of the rules. Then turn the supporter so that Figure 8 be in view at the left hand side of the mitering machine, and miter the next ends to length, which will give the miters perfect for any size eight sided design.

The outer circular edge on the bed of the mitering machine is marked with numbers 1, 2, 3, 4, 5, 6, 8, 10 and 12, which, as indicated in Diagram 1, correspond to 18, 22 $\frac{1}{2}$, 30, 45, 54, 60, 67 $\frac{1}{2}$, 72 and 75 degrees respectively.

Figures 0 and 3 $\frac{1}{2}$ on Diagram 1, corresponds to 15 and 36 degrees, illustrated by Figures H and R on Diagram 2.

When it is desired to miter a diamond place the supporter to the desired degree for one end of the rules, and the supporter

in the same position will be correct for the opposite end of the rules.

Thousands of these machines are in daily use and are giving perfect satisfaction to the users. The verdict is universal that they are the most accurate, the easiest and quickest to operate, and the most complete mitering machines on the market.

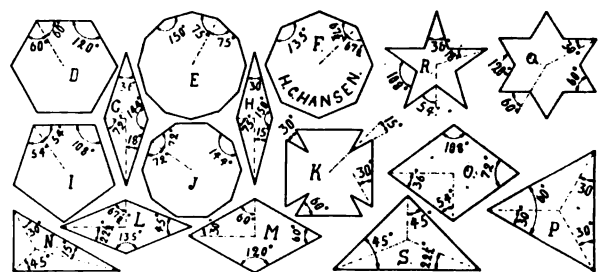
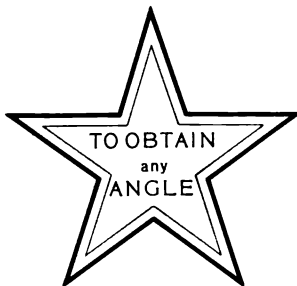

Diagram 2

THE H. C. HANSEN TYPE FOUNDRY



AMERICAN LEAD AND RULE CUTTERS

The gauges can be set instantly. They are self-locking. There are no screws to change from one hole to another. They cannot possibly slip. They are accurate and are guaranteed to remain so.

Cutter No. 30. Capacity, 105 ems;
by points, 45 ems.....\$12.00
Cutter No. 20. Capacity, 105 ems 10.00
Cutter No. 10. Capacity, 84 ems 7.00
Cutter No. 1. Capacity, 14 inches 6.00

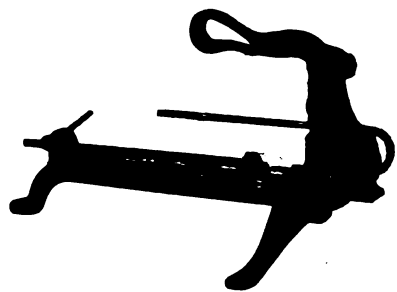

No. 1 Cutter

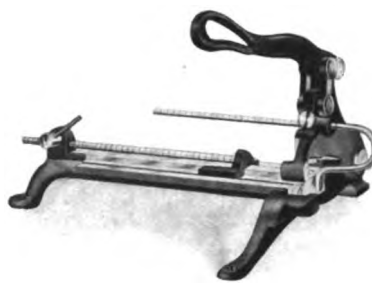

No. 10 Cutter

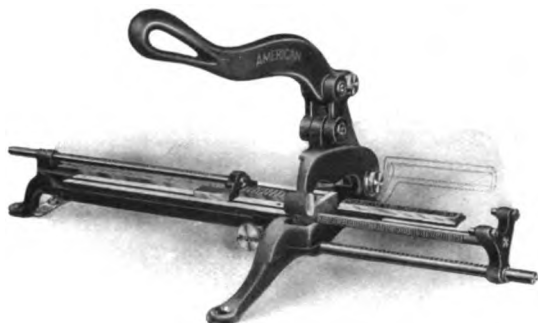

No. 20 Cutter

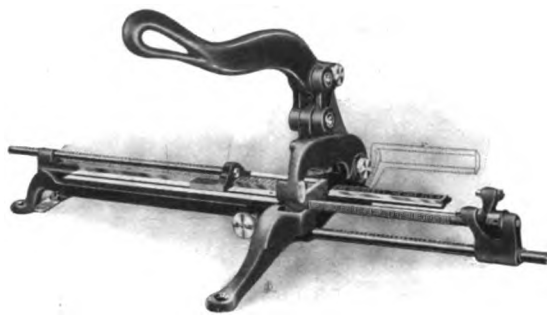

No. 30 Cutter

THE IDEAL VIBRATOR FOR GORDON AND PEERLESS PRESSES

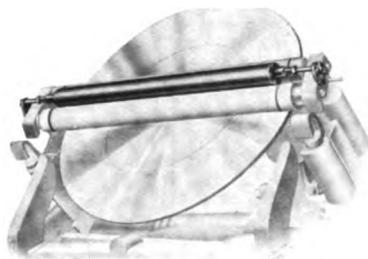

Ideal Vibrator on Gordon Press

The Vibrator rests between and travels with the two form rollers constantly distributing ink from one to the other. It saves ink, does away with double rolling, prevents streaking, and improves the quality of presswork.

7 x 11.....\$13.00	10 x 15.....\$15.00	13 x 19....\$17.00
8 x 12..... 13.00	10 x 16..... 15.00	14 x 20.... 20.00
9 x 13..... 13.00	11 x 17..... 16.00	14½ x 22.... 20.00
	12 x 18..... 17.00	

IDEAL FORM TRUCKS

Made in two styles, No. 1 having solid iron wheels, while the No. 2 is provided with rubber tires which prevent slipping and are easier to propel on any floor.

Boxed individually.
No. 1, Iron Tires \$3.00
No. 2, Rubber Tires \$5.00

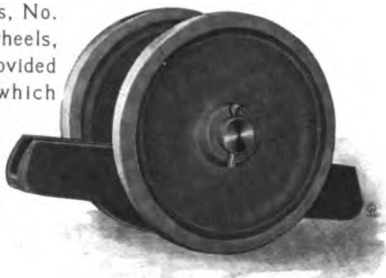

Ideal Form Truck

ROUSE REGISTER QUOINS

For use in forms of mounted plates where perfect register is desired. The quoins are placed on all four sides of each page.

Any page may be moved independently in any direction without disturbing the other pages. With No. 1 the margins can be regulated from 16 to 24 points, No. 2, 36 to 48 points.

No. 1, per doz.....\$2.00
No. 2, per doz..... 2.00
Key for either style..... .20

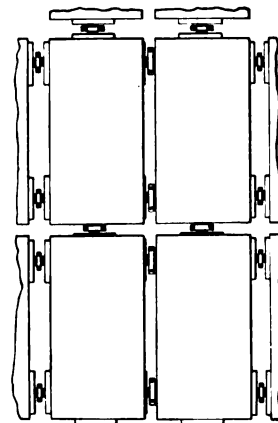

Register Hooks in Use



No. 1

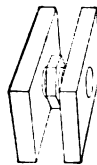

No. 2

PRESS POINTS

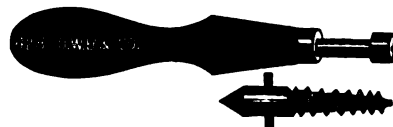

For inserting in wood furniture when sheets are printed for folding machine. Points are screwed into the wood as far as the cross pin will allow, when they will be correct height.

Price, per doz.....\$0.75 Wrench, each.....\$0.75

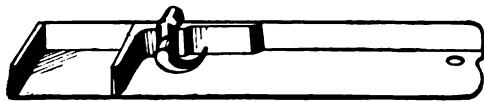

BUCKEYE JOB STICK

6-inch.....\$0.90 14-inch.....\$1.60
 8-inch.....1.00 16-inch.....1.80
 10-inch.....1.20 20-inch.....2.20
 12-inch.....1.40 24-inch.....2.60
 This stick is also made in the 1½ inch width. Prices: 6-inch,
 \$0.90; 8-inch, \$1.00; 10-inch, \$1.20



COMPOSING AND MAKE-UP RULES

Composing Rules
 To 15 ems, \$0.15. 16 to 20, \$0.20. 21 to 26½, \$0.25
 Make-up Rules
 To 15 ems, \$0.15. 16 to 20, \$0.20. 21 to 26½, \$0.25

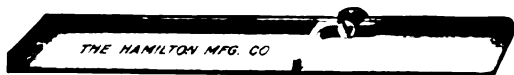

WOOD POSTER STICKS

Made of best seasoned cherry, with brass-lined ends, iron knee and screw clamp, 2½ inches wide. Extra width and full brass lined at special price.

16-inch.....\$1.00 30-inch.....\$1.35
 18-inch.....1.05 32-inch.....1.40
 20-inch.....1.10 36-inch.....1.50
 24-inch.....1.20 40-inch.....1.75
 28-inch.....1.30 42-inch.....1.80



POCKET RULE CASE

This is a handy set for carrying in the vest pocket. The case is made of strong brown leather, with patent clasps, and contains twelve steel composing rules. Sizes, 10, 12, 13, 14, 15, 16, 18, 21, 24, 26½, 28 and 30 ems pica.....Price, \$1.50

COMPOSING STICK RACK

The most convenient receptacle for sticks. Holds twelve sticks, any size, set to any measure. Sides are of japanned iron, attached to a varnished board.....Price, \$1.50

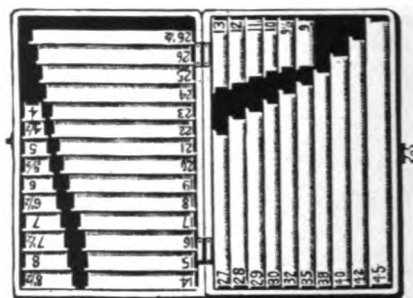
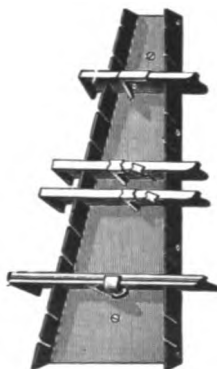

COMPLETE RULE CASE

This handsome case is strongly made of polished oak, lined with plush, and nicely finished. It contains an assortment of forty spring tempered steel composing rules from four to forty-five picas, numbered, and including half em measures below ten picas. It forms a valuable addition to the systematic job printer's outfit.....Price complete, \$3.50



UNBREAKABLE MITER BOXES

Made of lumber that is built up of different layers with the grain crossed, they will outwear the old kind many times.
 13½ ems wide.....\$0.50 3 inches wide.....\$0.60

BACK SAW

8-inch.....\$1.00
 10-inch.....1.25
 12-inch.....1.50

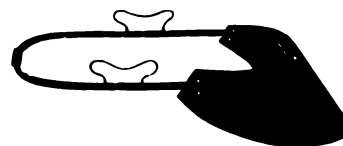
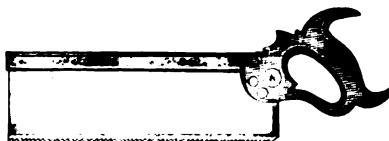

TYLER'S NON-CONTACT EYE SHADE

The best. Does not irritate the forehead; weighs but an ounce. Durable and adjustablePrice, \$0.25
 Regular Printers' Eye Shade..... .15



COMPOSING STICKS

THE ROUSE JOB STICK



Quickest to set; most perfect measure; stiffest knee; best clamp; faultless adjustment; unequalled construction; superior finish.

Length	2-inch	2½-inch	2¾-inch
6-inch Capacity 21 picas.....	\$1.75	\$1.85	\$1.95
8-inch Capacity 34 picas.....	2.00	2.10	2.20
10-inch Capacity 46 picas.....	2.25	2.35	2.45
12-inch Capacity 57 picas.....	2.50	2.60	2.70
16-inch Capacity 73 picas.....	3.00		

STANDARD JOB STICK

This stick is original in its action, absolutely correct, and cannot slip. It can only be set to picas and nonpareils on the point system. Its use will result in a great saving of time and material, as every lead and rule cut for jobs set in it must be on the standard, and no carelessness on the part of compositors setting sticks can lead to waste of material through cutting irregular measures. Prices and sizes same as Rouse sticks shown above.

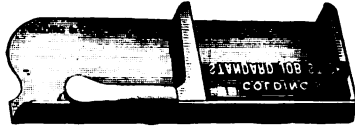

SCREW COMPOSING STICK Style B
Patent Adjustable Knee

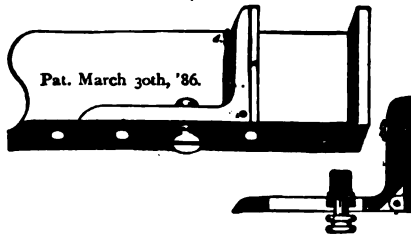

SLOT COMPOSING STICK Style C
Patent Adjustable Knee

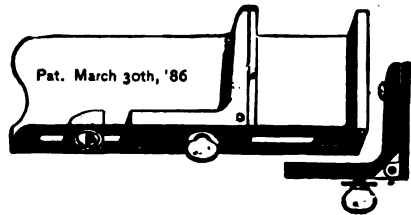

UNION COMPOSING STICK

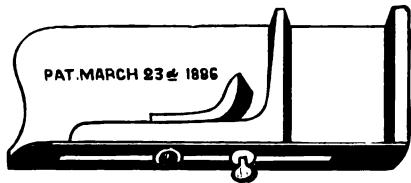

THE ALBION COMPOSING STICK

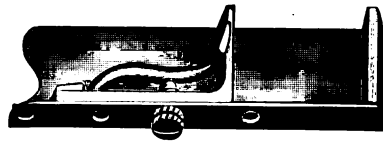

A screw stick with a greatly reinforced knee. The reinforcement is made of brass strongly riveted to knee at both ends.

COMMON SCREW STICK

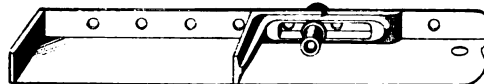

YANKEE JOB STICK



GROVER JOB STICK



PRICE LIST

	Screw	Style B	Style C	Union	Grover
6-inch	\$0.75	\$0.90	\$1.10	\$1.10	\$0.90
8-inch	.80	1.00	1.20	1.20	1.00
10-inch	1.00	1.20	1.40	1.40	1.20
12-inch	1.15	1.35	1.60	1.60	1.40
14-inch	1.30	1.45	1.80	1.80	1.60
16-inch	1.45	1.60	2.00	2.00	1.80
18-inch	1.60	1.80	2.20	2.20	2.00
20-inch	1.75	2.00	2.40	2.40	2.20

	Yankee	Standard	Albion
6-inch.....	\$0.70	\$1.75	\$1.10
8-inch.....	.80	2.00	1.20
10-inch.....	.95	2.25	1.30
12-inch.....	1.00	2.50	1.60
14-inch.....	1.30		1.80
16-inch.....	1.45		2.00
18-inch.....	1.50		2.20
20-inch.....	1.75		2.40

ELM CITY NEWS STICK
PISTOL GRIP HANDLE

This stick has no rival for news work. Made solid to measure there is no chance of its springing, and it can be used as the standard of the office. Being light, well-balanced, and shaped to fit the hand, the cramping grip necessary on the ordinary stick is done away with. Made to measure in 13 and 13½ ems.

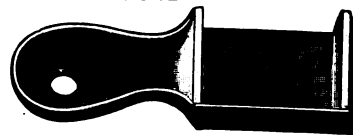

Price, Japanned.....\$1.00
Polished and Nickerled..... 1.25

PERFECT NEWS STICK No. 2



A desirable stick for newspaper composition. It is light, convenient and accurate. 2½ inches in depth.

No. 2, steel riveted, 13 ems measure.....each \$0.80

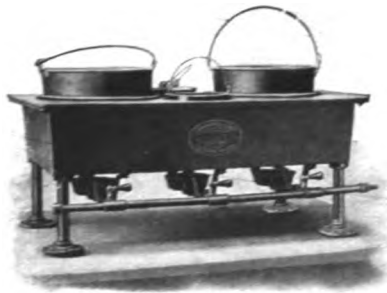

GAS GLUE HEATER

Consists of a cast iron box with cover in which are holes of suitable size to hold the pots. Each heater is equipped with copper pots, the only metal that will not discolor glue.

No. 1 Heater 2 five inch pots.....	\$15.00
No. 1 Heater 1 ten " "	15.00
No. 2 Heater 6 five " "	26.00
No. 2 Heater 2 five " " and 1 ten inch pot.....	22.00
No. 3 Heater 2 ten " " " 2 five " pots.....	30.00

Prices are for either gas or steam and subject to discount.

GLUE JACKET WITH POTS

Prices include the cast iron jacket with bolted rim, copper pot and two valves.

8 inch diameter of pot.....	\$14.00
7 inch " " "	11.00



GLUE POTS

1 quart.....	\$0.90
2 quart.....	1.20

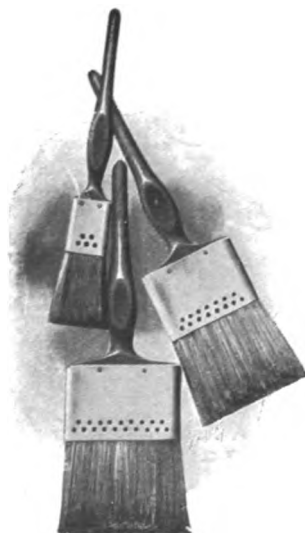

TIN BOUND BRUSHES FOR GLUE AND PASTE

Best quality bristles, double thick.

	Each
1 inch	\$0.30
1½ "40
2 "55
2½ "65
3 "70
3½ "75

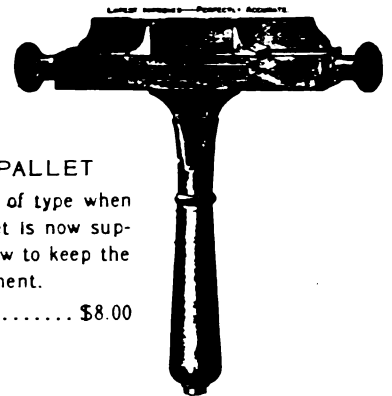

LETTERING PALLET

For holding lines of type when lettering. This pallet is now supplied with a face-screw to keep the type in perfect alignment.

Price..... \$8.00

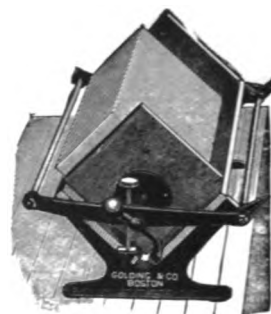

TABLET PRESSES

No. 1 will hold 2,000 sheets any size, up to 6x12 inches. Price..... \$6.00

No. 2 will hold 5,000 sheets any size, up to 8x16 inches. Price..... \$12.00

OILY WASTE CANS

No. 1, regular.....	\$2.00
No. 2, large	2.75

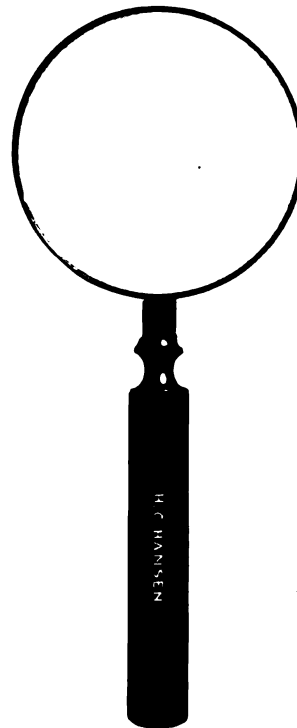

HIGH GRADE READING GLASSES

Every printer and publisher should have one.

They are strongly made and lenses are ground from extra white glass of strong curvatures, giving the best possible magnification.

2 inch diameter.....	\$0.60
2½ "	1.00
3 "	1.25
3½ "	1.50
4 "	1.75
4½ "	2.25
5 "	2.75
5½ "	3.50
6 "	4.00

Reducing glasses also furnished by request in the above sizes.

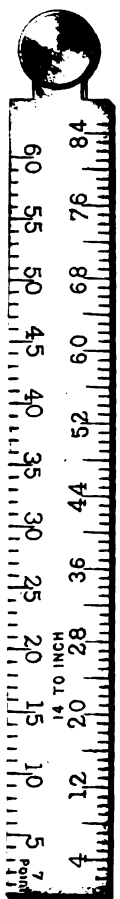

Fig. 1 Closed 6 Size

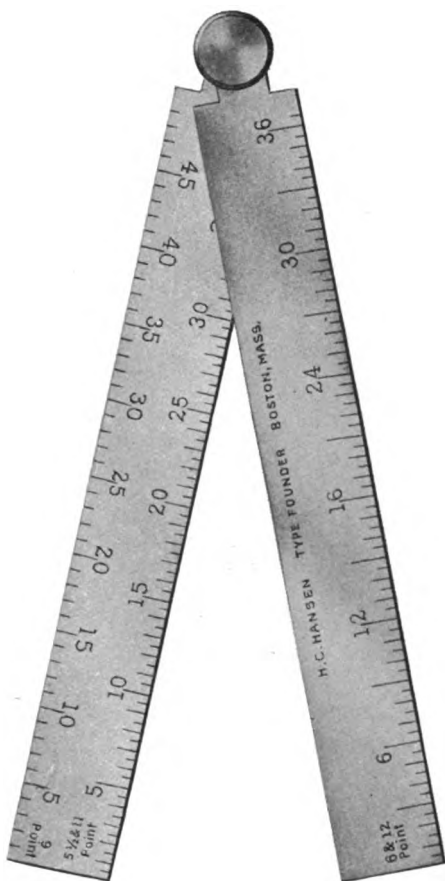

Fig. 2 Open 6 Size

HANSEN'S COMPLETE TYPE MEASURES

TWO SIZES, 4-INCH AND 6-INCH

4-INCH, \$1.00
6-INCH, \$1.50

Made of German Silver. It is the most complete Type Measure made, and the only one which can be used as a pair of dividers. The user can find the number of 5, 5½, 6, 7, 8, 9, 10, 11 or 12-points in the length or width of any size page or space.

Figure 1 is a reproduction of a 6-Inch Type Measure when closed, showing the 14 to the Inch measurement from 1 to 85 Agates in length. Also 7-point measurement, or 60 7-points in length.

Figure 2 shows Type Measure when open, illustrating two sides, giving the measures of 6 and 12-point, 5½-point, 11 and 9-point measurements.

These Type Measures fold to a convenient size for the pocket making them invaluable for Advertising solicitors and printing salesmen.

LEAD AND RULE MEASURES

Divided into Pica ems, point system, and has ends cut to 10 picas. Nickel-plated. Price, each\$1.00
Type Measures made to order

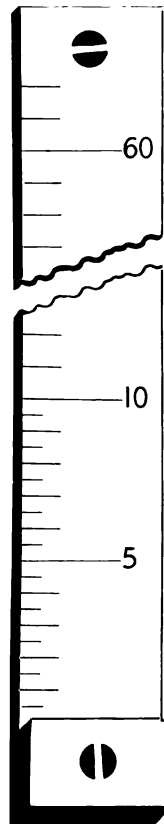

Lead and Slug Measure

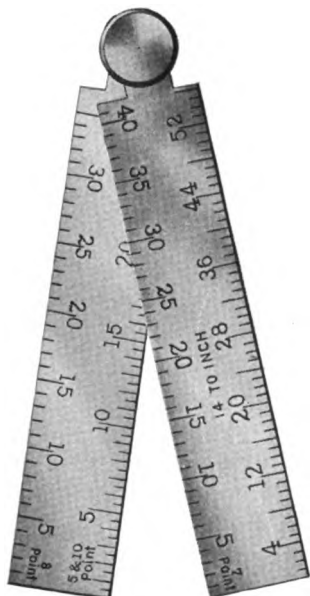

AGATE MEASURES

14 to Inch } 100 Agate\$1.25
 } 200 Agate 2.50

HANSEN BRASS LINE GAUGES

These line gauges are made of 5-point brass with lines and figures deeply and accurately cut. Made in 6 and 12 inch lengths.

	6-inch	12-inch
Pica, with hook	\$0.45	\$0.75
Pica and Agate, with hook60	.90
Nonpareil and Agate, with hook60	.90
Pica and Nonpareil, with hook60	.90
Pica, Nonpareil and Agate, with hook75	1.25

ELECTROTYPED TAKE SLUGS

4

Price, each\$0.15

BRASS TAKE SLUGS

2

Price, each\$0.20

THE H. C. HANSEN TYPE FOUNDRY



QUOINS AND LOCKING DEVICES

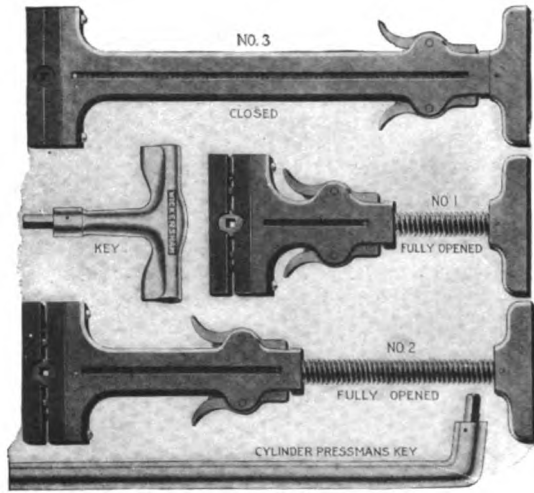

IMPROVED STEPHENS EXPANSION LOCKS

Takes the place of wood, empty chases, etc.; saves time; prevents spring.

No. 1, closed 4 1/2 in., fully opened 6 1/2 in.	price each, \$3.25
No. 2, " 6 1/2 " " " 10 1/2 " " " "	4.00
No. 3, " 10 1/2 " " " 18 1/2 " " " "	5.25
No. 4, " 18 1/2 " " " 34 1/2 " " " "	7.00



TRIAD QUOIN KEY

Two sizes of Hempel and the Wickersham on one body, making it a very handy tool for printing offices. Price, \$0.50

THE MINIKIN KEY
Vest pocket size. Suitable for small forms, galleys, etc. Price, \$0.25

THE REGULAR KEY
Shown with quoin. Reversible steel centers. Price, \$0.50

CYLINDER PRESSMAN'S KEY
Shown in opposite column. 10 inches long. A time-saver when quoins are at back of form \$0.60

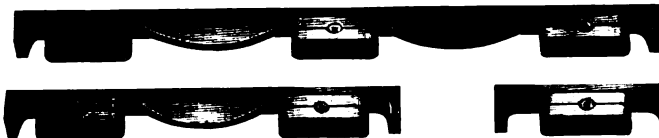

THE MORTON LOCK-UP

Consisting of quoins and furniture combined. These are made slightly under 12-point-em lengths to avoid end-bearings at foot of pages.

Length	Quoins	Each	Length	Quoins	Each
18 to 32 ems	1	\$0.40	17 inches	3	\$1.50
34 to 42 ems	2	.70	18 inches	3	1.75
45 to 54 ems	2	.75	19 inches	4	2.25
60 ems	2	.80	20 inches	4	2.50
66 ems	2	.85	21 inches	4	2.75
72 ems	3	1.10	22 and 22 1/2 ins.	4	3.00
78 ems	3	1.15	23 inches	4	3.25
84 ems	3	1.20	24 inches	5	3.75
90 ems	3	1.25	25 inches	5	4.00
16 inches	3	1.35	26 inches	5	4.25

The full space required between type and chase is 1 inch for the regular width Lock-up as carried in stock; or 3/4 inch for the special width Lock-up as fitted to order.

THE "MIDGET" SAFETY QUOIN

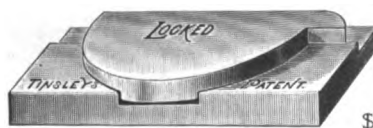

Specially adapted for the locking up of forms where space is limited as in mortises, etc.

\$2.00 per doz.

It is but 18 points in thickness, is simple, practical, safe and effective. Just the thing for ledger headings with but little space for end lock-up.



PERFECTED WICKERSHAM QUOIN

Each expands 15 points and locks by one turn of the key, at any expansion. Adaptable to all forms, small or large.

No. 1. 2 in. long x 3/8 in. wide	per doz. \$2.50
No. 2. 2 in. long x 1/2 in. wide	per doz. 2.50

HEMPEL'S PATENT QUOIN

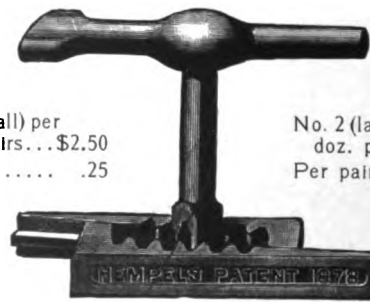

No. 1 (small) per doz. pairs... \$2.50
Per pair..... .25

No. 2 (large) per doz. pairs... \$3.00
Per pair..... .50

Challenge Hempel Quoins No. 1, per doz. pairs..... \$1.00
Challenge Hempel Quoins No. 2, per doz. pairs..... 1.50
Keys, Nos. 1 and 2, plain, \$0.50; nicked, \$0.75



WARRANTED STEEL SCREW DRIVERS

6-inch (whole length)	\$0.20
8 " " "	.25
12 " " "	.40
15 " " "	.50
18 " " "	.60

THE H. C. HANSEN TYPE FOUNDRY

a counter which records only for each individual job we recommend the new **Five Wheel Sheppard Counter** which registers from 1 to 99,999 and repeats. It can be set back to cypher in an instant and locked with a key, which prevents its being thrown out of count either intentionally or accidentally. It is constructed for durability and simplicity, having no springs to get out of order. The parts are all milled out of steel and can be relied upon for years of perfect service. It is the most reliable counter ever devised and will bear the most critical investigation. Each machine is fully guaranteed.

Price, \$10.00

Sheppard Counters Safeguard Your Interests

THE VERY BEST FOR THE MAN WHO PRINTS

THE H. C. HANSEN TYPE FOUNDRY

ESTABLISHED 1872

190-192 CONGRESS STREET, BOSTON

43 CENTRE STREET, NEW YORK

TYPE - MACHINERY - WOOD GOODS - SUPPLIES



DURANT COUNTING MACHINES



Especially adapted for printing presses. All working parts are of high-grade iron and steel. The machine is handsomely finished

and case is full nickel-plated. The dials have large black figures which are easily read at a distance. They may be easily and quickly reset to 0 or any number required. A bracket is furnished with each machine for convenience in securing it to the feed-board of press.

No. 1.	Counts	10,000	\$ 8.00
No. 2.	"	100,000	10.00
No. 3.	"	1,000,000	12.00

HART COUNTING MACHINES

Counts up to 100,000 and repeats automatically. It is accurate and durable.



Made in a thorough manner and guaranteed to be in every way reliable.

Hart Cylinder Press Counter No. 2, counts 100,000... \$6.00

COUNTER FOR JOB PRESSES

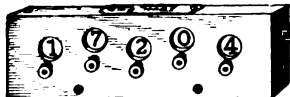

A reasonable-priced reliable counter for job presses. Made of best materials. Gears and dogs are stamped from steel and case hardened. Every part is first-class and nickel plated.

Size 1 1/4 x 4 1/2,	registering	10,000	\$3.00
" 1 1/2 x 5 "	"	100,000	3.25
Press attachment, each		50

THE HART SPRINGLESS COUNTER



Counts only sheets printed. If the throw-off is made within 1/4 inch of the impression the sheet will not be counted. Nothing to get out of order as all gears and weights hang on rods and depend on gravity and not on springs. Suitable for either

job or cylinder presses. Made throughout of iron and brass. Set to 0 in a moment.

Hart Springless Counter	\$5.00
Complete with Press Attachments	6.10

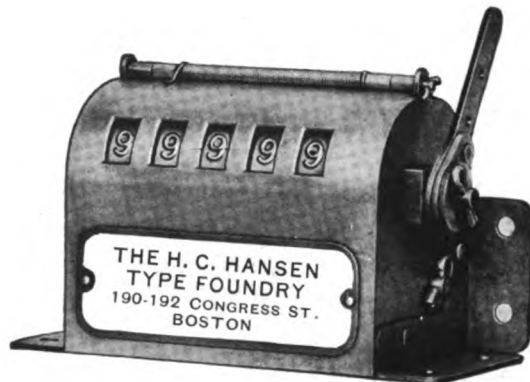

THE REDINGTON COUNTING MACHINE

The Redington Counting Machine has all the necessary qualifications for accurate and rapid counting, is durable, neat in appearance, convenient in size and low in price. All parts are made from sheet steel formed by dies and are, therefore, interchangeable. Simplicity in design, heavy material and large wearing surfaces insure ease of operation and long life for the counter. All working parts are enclosed and protected, yet easily accessible for oiling as the case opens both front and back, exposing mechanism for oiling and inspection. The counter can be set back to 0 without the use of a key or other device. It can be run at any speed without jumping or losing count. Size 3 1/2 x 2 1/2 x 2 1/2 inches.

Redington Counting Machine..... \$5.00

IMPROVED HORTON MAILER

The Horton Mailer is guaranteed to do first class work at a high rate of speed.

It is light and compact, and requires very little space.

It is perfectly constructed from the most durable metals.

It is 12 inches long, 3 inches wide, 5 inches high, and weighs two and three-quarter pounds

When ordering be sure to give width of the mailing slip.

Regular No. 1 Mailer, taking a mailing strip not exceeding 1 1/2 inches	\$20.00
Special No. 2 Mailer, taking a mailing strip not exceeding 2 1/2 inches	\$30.00

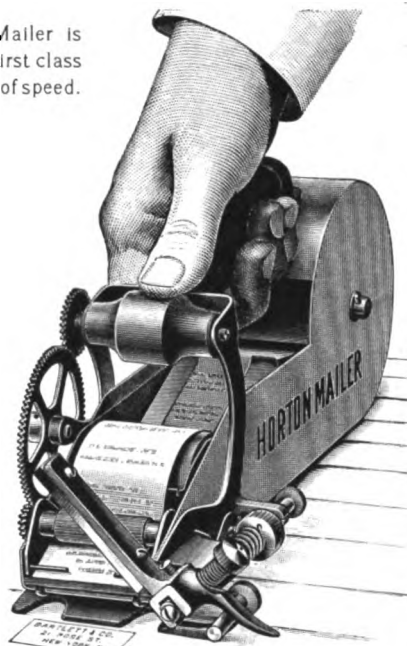

THE H. C. HANSEN TYPE FOUNDRY



HANSEN ALL BRASS RIVETED GALLEYS

An All Brass Riveted Galley having the strongest, most durable and most symmetrical corners to be found on any galley of this description on the market. Our galley, in addition to having an interlocking corner, has a rivet in the exact center of the corner extending through the bottom plate, side and end piece, making a secure fastening and guarding against all possibility of springing or breaking.

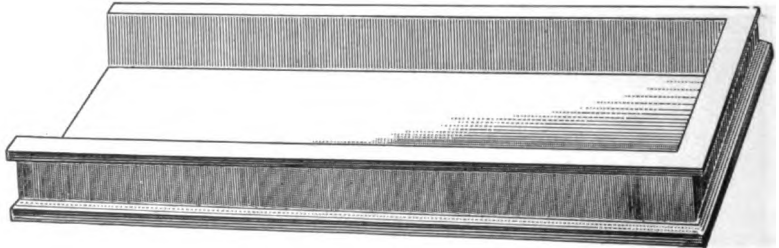

The Hansen All Brass Riveted Galley

By our method of interlocking and fastening the corner, all sharp and ragged edges are done away with and the corners are as smooth and symmetrical as the bottom of the galley itself. The bottom plates are of the best obtainable material and are absolutely accurate and of standard thickness. The sides are grooved in such a manner as to give a firm hold for the fingers when lifting. The accompanying cuts give a clear idea of the strength and beauty of these galleys. Although of Hansen Superior Quality they cost no more than the ordinary.

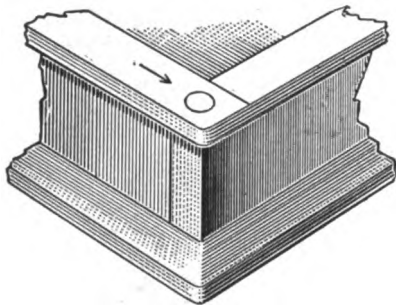

Showing Our New Corner Securely Held by Rivet

JOB GALLEYS			
6 x 10 Inches Inside	\$2.00	12 x 18 Inches Inside	\$4.00
8 1/2 x 13 " " "	2.50	14 x 21 " " "	4.75
9 x 14 " " "	2.75	15 x 22 " " "	5.25
10 x 16 " " "	3.25	18 x 25 " " "	7.00

NEWS GALLEYS			
Single Col. 3 1/2 x 23 1/2 Inches Inside	\$2.50	Triple Col. 8 1/2 x 23 1/2 Inches Inside	\$3.50
" " 3 1/2 x 15 1/2 " " "	2.00	Four " 10 1/2 x 23 1/2 " " "	4.25
" " 3 1/2 x 11 1/2 " " "	1.75	Five " 13 x 23 1/2 " " "	5.00
Medium " 5 x 23 1/2 " " "	2.75	Six " 15 x 23 1/2 " " "	5.50
Double " 6 1/2 x 23 1/2 " " "	3.00	Seven " 17 x 23 1/2 " " "	6.25
" " 6 1/2 x 15 1/2 " " "	2.50	Eight " 19 x 23 1/2 " " "	7.00
" " 6 1/2 x 11 1/2 " " "	2.25		

Other sizes made to order at proportionate prices

LINCOLN PATENT ALL BRASS GALLEYS

Standard among self-locking galleys. It is made to order only. Care should be taken in ordering to see that correct measure is given for width of column.

12 in. long, not exceeding 15 ems pica wide	\$2.00
16 " " " " 15 " " "	2.50
24 " " " " 15 " " "	3.00
24 " " " by 25 ems pica wide	3.50
For each additional pica em exceeding 15 ems pica, add to the list price	.05
Extra Foot Clamps, each	.50

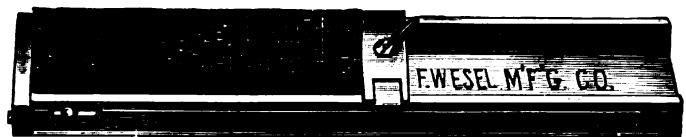

Lincoln Galley, showing type matter locked on sides and end

WESEL PATENT ALL BRASS LINOTYPE GALLEY

Style A has one low side. Style B both sides high.

12 in. long, not exceeding 15 ems pica wide	\$1.50
16 " " " " 15 " " "	1.75
24 " " " " 15 " " "	2.00
For each additional pica em in width exceeding 15 ems pica, add to list price	.05
Extra Foot Clamps, each	.50

The prices include Foot Clamp. In ordering, it is necessary to give exact width of column and to send sample linotype slug; also state whether Style A or Style B is wanted.



Linotype Galley, Style B



MUSTANG MAILING GALLEY

Zinc bottom, Price each \$0.50

CHALLENGE PLATE ZINC GALLEYS

Job and Book, 6 x 10 Inches Inside	\$0.80
" " " 8 1/2 x 13 " " "	.95
" " " 10 x 16 " " "	1.30
News, Single Column, 3 1/2 x 23 1/2 Inches Inside	.75
" " " 3 1/2 x 11 1/2 " " "	.60
" " Double " 6 1/2 x 23 1/2 " " "	1.00
Mailing Galleys, 3 1/2 x 22 1/2 Inches Inside, closed ends	.95
" " " 6 1/2 x 22 1/2 " " "	1.20

Reduced prices on quantities of 100 or more



PATENT STEREOTYPE BLOCKS

APPROXIMATE SIZES AND PRICES

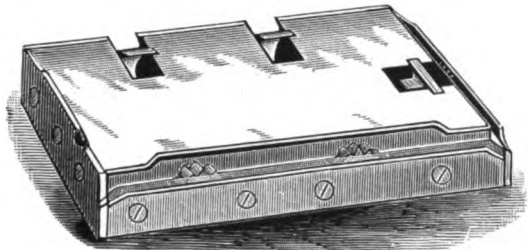

Improved Plain Old Style Block, with Patent End Hook

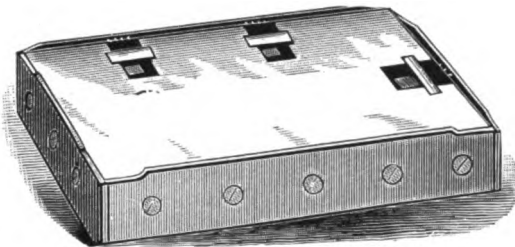

New Style Block, with Patent Side and End Hooks

The above cuts represent our new Stereotype Blocks, with End Hooks, for Cylinder Presses. They are made of the best San Domingo Mahogany, thoroughly seasoned, and every part is made and fitted with the utmost care. The superior quality of material and the workmanship in these blocks, and their accuracy is well known; they recommend themselves.

Owing to the number of different sizes, and the uncertainty of demand, we cannot undertake to carry a full line of these blocks in stock, but are prepared to fill orders for any quantity at short notice.

In ordering blocks, state whether patent or plain, with or without end hooks, and if any additional hook is wanted. Also state size of block over all, with sizes of largest and smallest plate to be worked, measuring the plate from the back. All blocks are made 1/4 of an inch thick unless otherwise ordered. Blocks without End Hooks are for Bed and Platen Presses, those with end hooks are for cylinders.

SIZES.	WITHOUT END HOOKS.				WITH END HOOKS.		
	Outside Dimensions of Blocks.	No. of Side Hooks.	Plain Old Style.	Patent New Style.	Whole No. of Hooks.	Plain Old Style.	Patent New Style.
Folio:							
Imperial	16 x 22 1/4	4	\$5.00	\$6.25	7	\$7.25	\$8.50
Sup. Royal..	13 1/4 x 21 1/4	4	4.55	5.70	7	6.80	7.95
Royal	12 1/4 x 19 1/4	4	4.20	5.25	7	6.40	7.45
Medium.....	11 1/4 x 18 1/4	4	3.90	4.80	7	6.10	7.00
Quarto:							
Imperial	11 x 16	4	3.75	4.50	6	5.30	6.10
Sup. Royal..	10 1/4 x 13 1/4	3	3.10	3.75	5	4.50	5.25
Royal	9 1/4 x 12 1/4	3	2.95	3.50	5	4.25	4.90
Medium.....	9 x 11 1/4	3	2.80	3.30	5	4.00	4.60
Octavo:							
Imperial	7 1/4 x 11	3	2.65	3.10	4	3.30	3.80
Sup. Royal..	6 1/4 x 10 1/4	3	2.50	2.90	4	3.15	3.60
Royal	6 x 9 1/4	3	2.40	2.75	4	3.00	3.40
Medium.....	5 1/4 x 9	3	2.30	2.60	4	2.85	3.25
Demy	5 1/4 x 7 1/4	3	2.20	2.45	4	2.70	3.10
Duodecimo:							
Broad	5 1/4 x 6 1/4	2	1.65	1.90	3	2.05	2.45
Sixteen mo:							
Sup. Royal..	5 x 6 1/4	2	1.50	1.70	3	1.95	2.30
Medium.....	4 1/4 x 6	2	1.40	1.60	3	1.85	2.15
Demy	3 3/4 x 5 1/4	2	1.30	1.50	3	1.75	2.00
Eighteen mo:							
Medium.....	3 1/4 x 5 1/4	2	1.30	1.50	3	1.75	2.00
Thirty-two mo:							
Sup. Royal..	3 x 5	2	1.20	1.40	3	1.65	1.85

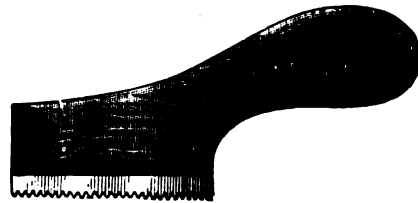

RACHETS FOR STEREOTYPE BLOCKS

These Rachets are strongly made in brass and steel riveted to Wood or Steel handles.

Brass, Wood or Steel Handle..... \$0.50
Steel, " " " "75

EMBOSSING COMPOSITION



BURBANK'S EMBOSSING COMPOSITION

This composition is a plastic cement, about the consistency of ordinary putty, which becomes as hard as stone on exposure to the air. It will not crumble, and will stand an unlimited number of impressions without losing its sharpness. A pound can contains sufficient composition for a dozen or more ordinary jobs.

Price, per can..... \$0.75





MULLER PATENT HALFTONE SOFTENING HAMMERS AND PUNCHES



For softening harsh vignettted edges of illustrations, whether original halftones, electros, stereos, or woodcuts.

Lines to match any screen are cut on a convex surface, in hand-forged steel. Hammers are also made for use on stipple and grain work.

The harsh edges of cut are tapped with hammer, and the results are magical. No special skill is required.

Punches are for use where there is no room for the hammer. Any screen desired is furnished, and a different screen at each end of No. 1 Hammer. In ordering, state screen desired. It is not necessary that the screen on hammer should exactly match screen used on plate, but the screen on hammer should not be coarser than screen on the work.

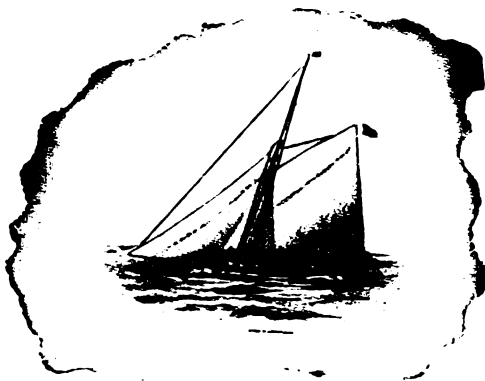

Before using Muller Hammer on Halftone

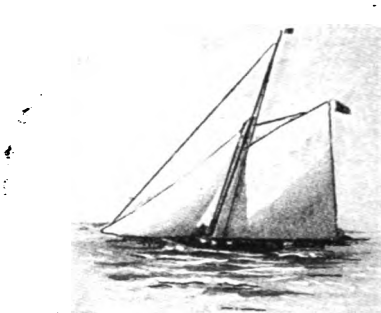

After using Muller Hammer on Halftone

PRICES OF SOFTENING HAMMERS AND PUNCHES

No. 1 Hammer, with different screen at each end.....	\$5.00
No. 2 Hammer, with screen at small end and stipple at large end.....	6.50
No. 3 Hammer, with screen at small end and burnisher at large end.....	3.50
Oblong Punch, any screen, $\frac{1}{2} \times \frac{3}{8}$ Inch.....	1.50
Square Punch, any screen, $\frac{1}{2} \times \frac{1}{2}$ Inch.....	1.50
Diamond Punch, any screen, $\frac{1}{2} \times \frac{1}{2}$ Inch.....	1.50
Oblong and Square Punches, for Stipple.....	2.50

SOUTHWORTH PUNCHING MACHINE



This is a convenient and powerful hand punch. It contains exclusive features which only have to be seen to be appreciated. Full description of this remarkable machine, together with diagram showing the fourteen different sizes of punches, mailed on application.

The price of the Southworth Punching Machine includes one punch, die and stripper. No. 6, which is 3-16 inch diameter, is always sent unless otherwise directed. Additional sizes are \$2.00 per set.

Southworth Punching Machine.....\$15.00

THE H. C. HANSEN TYPE FOUNDRY



HANSEN'S SOLID BRASS GAUGE



Many pressmen prefer these Gauges to any other kind, especially for registered color work. They are easily and quickly secured to the tympan sheet with either paste or mucilage, and will not slip. Made in 10, 12 and 18-point thicknesses, and furnished assorted if desired. Price, 5 cts. each, or 50 cts. per doz. A great improvement over the old quad gauge.

SPRING TONGUE GAUGE PINS

A most satisfactory gauge pin. Adjustable same as "Originals." Has back stays which carry a tongue adjustable to all margins. Price, \$1.20 per doz. 40 cts. per set of 3, including extra tongues.



Tongues 25 cts. per doz.

Explanation of Numbers for use in ordering Original and Golden Gauge Pins

No. 1, 12 points high; No. 2, 15 points high; No. 3, 18 points high; each with 1-16 inch lip. No. 4, 12 points high, no lip. No. 5, 15 points high, 1-8 inch lip. No. 6, 12 points high, 1-4 inch lip. All gauges with tongues, unless otherwise stated, are 12 points high.

ORIGINAL STEEL GAUGE PINS



Has double-thick head presenting a full face.



No. 2 secured to the tympan, with sheet fed.

The prong is inserted quarter inch below feed-line and brought up through. Register may then be obtained and the teeth forced down to hold position and keep sheets from feeding under. Nos. 1, 2, 3, 4. Price, 60 cts. per doz.

GOLDEN STEEL GAUGE PINS



Adjustable same as "Originals." Fit into corners of envelope blanks. Straight sides. Nos. 1, 2, 3, 4, 5, 6. Price, 40 cts. per doz.

FLEXIBLE GAUGE PINS

Relaxes under pressure and as a side gauge, is used directly under gripper without injury. Attached in same manner as "Originals." Price, with or without lips, 60 cts. per doz.

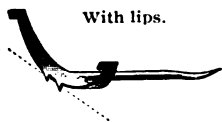

With lips.

SCREW ADJUSTING GAUGE PINS



Has a range of adjustment of nearly half an inch. The prong is inserted below the feed-line and forced home. Adjustment is obtained by turning the little nut. Price, including extra tongues, \$1.00 per set of 3.

DOUBLE-GRIP GAUGE

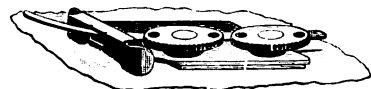

Fastens through a single slit cut in direction of adjustment. Any degree of adjustment. No pin-points or glue. Tympan can be re-used. Two nuts clamp vise-like on edge of slit. Unequaled for heavy stock. The strongest hold on tympan ever obtained. Price, including extra tongues and key, \$1.25 set of 3.

PERFECT REGISTER GAUGE

Secured to the tympan with glue. Gives fine and accurate adjustment by movement of disk. Quickest means of getting forms in register in color work. Front prong enters tympan and keeps sheets from feeding under head. Price, including extra tongues, \$1.25 set of 3.



ECCENTRIC STUD GAUGE

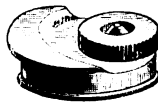

Secured in suitable slits or holes cut in tympan. Price, 75 cents per set of 3.

EXTENSION FEED GUIDES

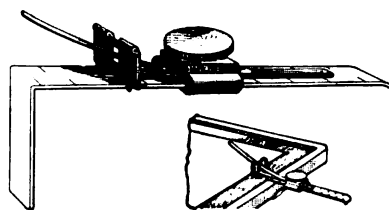

Fasten in the tympan Bail. Gauge sheets at lower edge of platen, from about an inch above to nearly two inches below if allowed by press. Easy to secure and adjust. Price, \$1.00 per pair, including pair short guides and long tongues.

CYLINDER PRESS SIDE GUIDE

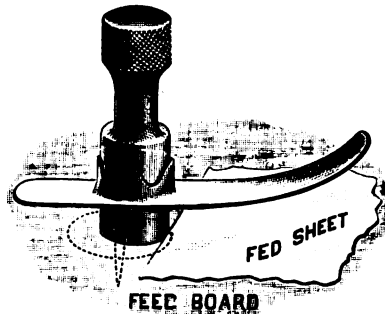

Secured by driving point in feed board just off feed line. Fine register quickly made by turning the pillar. The bendable brass tongue may be raised, lowered or directed over sheet as desired. Saves feed-board as close changes of point are unnecessary. Price, 50 cts. each.

IRON GAUGE PIN DRAWER

A handy place for gauge pins when not in use. Price, 25 cents each.

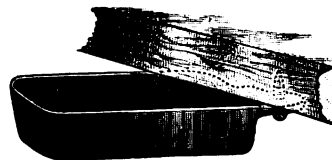

GRIPPER FINGERS



Designed for the platen press and apply quickly and adjustably to any shape or size of gripper, holding immovably. Meet innumerable conditions for relieving sheets from the form. 50 cents each.



WOOD QUOINS

Kind	Boxes of 100	Bags of 500	Bags of 1000	Barrels of about 7500 per 1000
Hickory.....	\$0.40	\$1.80	\$3.50	\$3.25
Boxwood.....	.60	2.70	5.25	5.00
Lignumvitæ.....	.80	3.60	7.00	

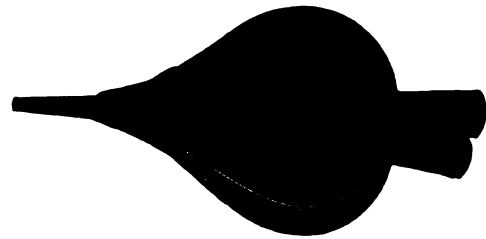

BELLOWS

Correct in shape and made of best materials, with reed to assist inflation; few bellows sold to printers have this feature. Small size, 8 inches, \$1.00 Large size, 10 inches, \$1.25



WELLS LONG WOOD QUOINS

Improved by top notch, which greatly assists in unlocking forms. Made in four sizes, all working in pairs with straight furniture, or they can be used singly with side sticks.

No. 1.	Boxes of 100.....	Hickory	\$0.75	Boxwood	\$1.10
No. 2.	" " " ".....	"	.75	"	1.10
No. 3.	" " " ".....	"	1.10	"	1.75
No. 4.	" " " ".....	"	1.10	"	1.75



UNIVERSAL DUSTER AND BELLOWS

- No. 1. Length of cylinder 16 inches, inside diameter 2 3/8 inches, entire length 20 inches..... \$1.25
- No. 2. Length of cylinder 18 inches, inside diameter 2 1/2 inches, entire length 22 3/8 inches..... 1.50



SHOOTING STICKS

Polished steel.....	\$0.60
The H. C. Hansen, forged steel.....	.75
Malleable Iron, enamelled.....	.25
" " Brown's Patent, plain.....	.50
Brass, Brown's Patent, polished or nickel plated.....	.75



ADZIT GALLEY LOCK

The Adzit Galley Lock is a simple, positive lock for locking linotype slugs or type in plate zinc or galvano steel galleys or galleys of like construction. For linotype slugs no side lock is necessary as this lock holds matter firmly in place. Equally useful for type. It will grip instantly and firmly at any point on the side of the galley and a simple pressure releases it.

Single column.....	each \$0.15	per doz. \$1.50
Double column.....	each .20	per doz. 2.00



HAMILTON NEWSPAPER FILE

This is a most satisfactory newspaper file. It is strong and efficient, yet is simple in its operation. The method of opening and closing the file is novel and simple. The clasp end of file has a flat-headed thumbscrew which is passed through a slot, and by giving the screw a quarter turn the file is securely locked. When the head is turned parallel with the file it opens instantly. In stock in the following sizes: 4-column paper, 16 1/2 inches clear, 10 ounces; 5-column paper, 20 1/2 inches clear, 11 ounces; 6-column paper, 22 1/2 inches clear, 12 ounces; 7-column paper, 24 1/2 inches clear, 13 ounces; 8-column paper, 26 1/2 inches clear, 16 ounces; 9-column paper, 28 1/2 inches clear, 17 ounces. List price.....each, \$1.25

THE H. C. HANSEN TYPE FOUNDRY



BATES NUMBERING MACHINES

AUTOMATIC HAND NUMBERING MACHINE

Model No. 49

Designed to meet the popular demand for a very moderately priced automatic numbering machine of durable construction, capable of accurate work. Numbers from "1" to "999,999." It is made to number consecutively, in duplicate, and repeat continuously. The figures are automatically inked before each impression from a thick felt pad. Weight, 12 ounces.....Price, \$3.50



123456
FAG SIMILE IMPRESSION
Model No. 49

AUTOMATIC HAND NUMBERING MACHINE

Model No. 50

This model embodies the highest achievements in the art of numbering machine construction. Numbers from "1" to "999,999." Made to number consecutively, in duplicate and repeat continuously. The figures are automatically inked before each impression, from a thick felt pad. The pad holder may be instantly removed for re-inking. All metal parts made of steel. Weight, 14 ounces. Price, \$10.00



123456
FAG SIMILE IMPRESSION
Model No. 50



No 12345

STANDARD TYPE-HIGH NUMBERING MACHINE Model No. 27

A type-high automatic numbering machine, designed to be locked in the chase with the form, wholly surrounded by type matter or used separately to print number only. Every figure disc is advanced automatically from "1" to "99,999." Provision is also made for skipping any number necessary, as is required for check and other work with several forms to a page. Size, 1 1/2 x 15-16 inches.....Price, \$ 8.00
Model 28. 6-wheel, numbering to "999,999"..... 10.00
Prices of other styles and sizes on request

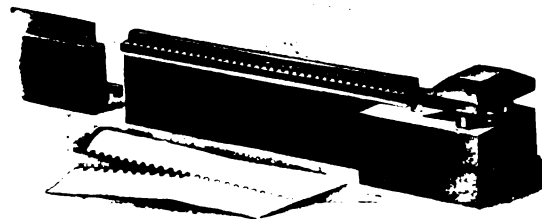

PERFORATING AND SCORING MACHINE Models 45 and 46

Designed to be locked in form separately, when there is no printing or numbering to be done, or imposed together with typographic numbering machines and entirely surrounded with type matter. The cases are made to the point system and the style of perforating is the colorless pinhole variety in appearance. No tympan attachments are necessary. Two or more of the blades interlock so that any length of perforation may be obtained. The release of plunger after each impression allows perforating blade to drop below type high thus preventing contact with inking rollers. Creasing or scoring blades may be used with same cases and driving head.

Perforating Machine
3-in. sections, each, \$6.00 No. 46 Driving Heads, \$4.00
2-in. sections, each, 5.00 Scoring Blades..... 2.50

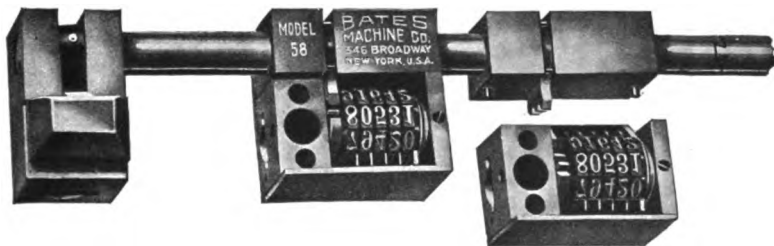

MODEL NO. 58

This attachment is designed to operate Standard Models No. 27, 28 and 29 with their plungers removed and without any characters preceding the figures. A shaft to which the actuating-pawl-swings are geared, transmits the necessary movement. The driving-head and the first section of shaft is 12 inches over all. Additional sections of

shaft (6 inches long) with dove-tailed ends designed to be assembled to each other, provide for any necessary length from 12 to 48 inches and will operate from one to twenty numbering machines. Detailed description and prices on application

THE H. C. HANSEN TYPE FOUNDRY



WETTER NUMBERING MACHINES

STANDARD MODEL

The Standard Model Wetter is a type high machine operated by a plunger with the word "No." to precede the figures. It can be locked in the form with type and printing and numbering done at one impression. With each machine is furnished a blank to be used with a frisket in place of the word "No." when working on a job

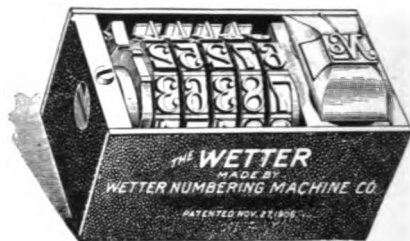

press when it is desirable to

have only the figures print. Made of best material and is fully guaranteed.

SOME OF THE STANDARD MODELS: ORDER BY MODEL NUMBER

Model	Number of Wheels	STYLE OF FIGURES	Height Inches	List Price	Code Word	
237	3	No 12345	Type High	\$10 00	Jay	
186	4			11 00	June	
125	5			8 00	Jimmy	
126	6			10 00	Jaguar	
127	7			19 00	Jasper	
188	3	No 1234	Type High	10 00	Key	
182	4			11 00	Keel	
130	5			8 00	Karat	
131	6			10 00	Kopeck	
132	7			19 00	Kindle	
238	3	25098	Type High	12 00	Lay	
217	4			14 00	Love	
135	5			16 00	Leach	
136	6			19 00	Launch	
239	4	123456	Type High	22 50	Meat	
138	5			25 00	Mouse	
139	6			28 00	Monkey	
140	7			32 00	Martel	
210	4	2345	1 1/2	53 00	Over	
196	5			55 00	Omen	
181	6			60 00	Ourang	
211	7			65 00	Otter	
242	3	No 123456	Type High	14 00	Rain	
187	4			16 00	Roach	
147	5			18 00	Racket	
148	6			21 00	Radish	
149	7			24 00	Rafter	
197	3	1234	Type High	16 00	Enter	
198	4			18 00	Ending	
199	5			22 00	Ethics	
244	4	78490	Type High	21 50	Titter	
156	5			27 00	Teale	
157	6			30 00	Tavern	
158	7			33 00	Taunt	
191	3	12345	Type High	24 00	Pack	
144	4			25 50	Part	
145	5			27 00	Pint	
146	6			30 00	Parry	
241	7			33 00	Pearl	
206	3	12358	1 3/4	43 00	Bank	
192	4			45 00	Bike	
105	5			47 00	Baked	
207	6			50 00	Butter	
171	2	1 to 50 and repeat	Type High	10 00	Congo	
172	2	50 to 1 and repeat		10 00	Congoback	
283	2	No 23	Type High	12 00	Sail	
264	2			1 to 00 and repeat	12 00	Sailor
173	3			00 to 1 and repeat	14 00	Dancer
174	3			1 to 100 and repeat	14 00	Dancerback
204	3	678	1 1/2	54 00	Office	
194	4			55 00	Onyx	
143	5			56 00	Oregon	
205	6			60 00	Oxygen	

We Make to Order Machines to Meet Every Requirement

THE "BETTER WETTER"

A type-high numbering machine which prints figures only—no plunger. The pressure of the platen or cylinder on the figures operates the mechanism which changes the numbers and also brings into action ingenious bearers which raise automatically and hold the printed sheet off the figures while they are changing. It is easily taken apart for cleaning. Made of best material throughout, insuring perfect accuracy and durability.

Styles and prices on application.

SKIPPING UNIT WHEELS

For numbering checks with stubs any number to a page "skipping" unit wheels are necessary; these are interchangeable with the consecutive unit wheels furnished with each machine and can be adjusted to the machine by any printer.

Skipping Wheels (to skip any one number from 2 to 9) each \$2.50
Letter Slides (one letter) each50

Any model "Wetter" will be made, on special order, to number backward without extra charge. Backward machines do not automatically depress the drop-ciphers.



No. 27 Galley Top Wisconsin Cabinet, with Copy Drawer
Prices and specifications on page 301

THE H. C. HANSEN TYPE FOUNDRY



EJECTOR PRESS PUNCHES

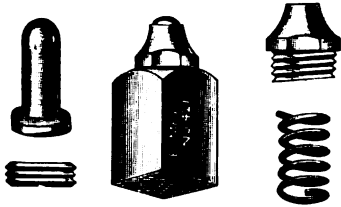

One or more can be locked in a form. Will cut clean holes at same time job is printed. Cuttings are ejected after each impression. The plunger protects rollers from injury. Parts are inter-

changeable. Springs can be made stiffer by turning screw in base. Brass rule should be used under outer sheet of tympan so as to get clean cut holes.

Made to punch holes in six sizes, 3-32, 1-8, 3-16, 1-4, 5-16 and 3-8 inches diameter.

Sets of four, viz: 3-32, 1-8, 3-16, 1-4 inch.....	per set, \$3.00
Sets of three, any assortment.....	per set, 2.25
Either size.....	each, .75
Sets of two, 5-16, 3-8 inch.....	per set, 2.50
Either size.....	each, 1.25
Renewals for 3-32, 1-8, 3-16, 1-4 ins.	For 5-16, 3-8 ins.
Cutters.....each, \$0.35	each, \$0.60
Screws..... " .10	" —
Square Bases..... " .20	" .40
Plungers..... " .10	" .20
Springs..... " .05	" .05
Cutting plates..... doz. .10	doz. .10

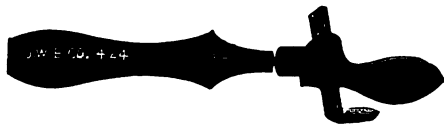

PAPER COUNTER

Each..... \$0.75



STEEL TABLET KNIVES

Each..... \$0.35



PRINTERS' BODKINS

Wood handle, steel needle.....each, \$0.10



TEMPERED STEEL DIVIDERS

Nickeled, 5 Inches.....\$1.00
Plain, 5 Inches......85

TWEEZERS



No. 91. 3½-in. Nickel..... \$0.30



No. 50 4¼-in. File cut backs and points, nickel..... \$0.85

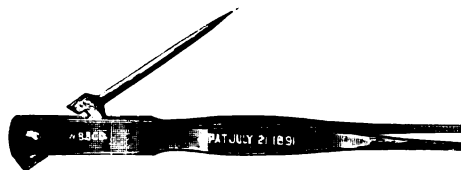

No. 54. 4¼-in. File cut backs and points, nickel..... \$1.00



No. 35. 4¼-in. File cut backs and points, with pin... \$0.85



No. 40. 4-in. File cut backs and points, nickel..... \$0.75
No. 40B Same as No. 40, but without back pin or shim. .50



No. 41. Same as No. 40 but with narrower points for very small type..... \$0.75



No. 51. 3½-in. closed. Nickel..... \$0.65



OPEN.

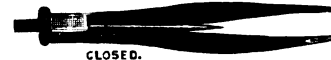

CLOSED.

No. 55. Tweezers with reversible bodkin..... \$0.60

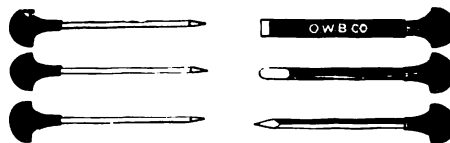

ENGRAVING TOOLS

Ground and sharpened ready for use. Per set of 6, \$2.50



**CHALLENGE
STEEL SECTIONAL BLOCKS**

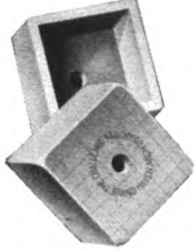

8 x 8, each.. \$0.18
2 x 8, each.. .09
2 x 6, each.. .08

**LITTLE GIANT REGISTER
HOOK**

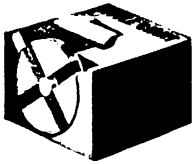

Made from solid brass. The screw and slotted head are in one piece, cut from steel, and tempered; the clutch is also made of steel, and there are but four pieces to each hook. It is actuated by a steel key. It is designed especially for fine register and color printing.

Little Giant Register hooks, 6 x 8 ems..... \$1.00
Steel Keys, 2-inch.....each, \$0.05
Steel Keys, 4-inch, with double end.....each, .20

EUREKA REGISTER HOOK

Made from solid brass, clutch and screw of steel. Slotted head of steel, tempered. Eighteen points between plates is all that is required for clutch and slotted head.

Designed for use between plates where it is necessary to work to narrow margins.

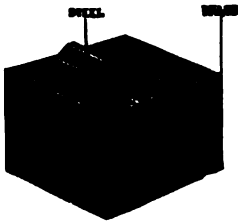

Eureka Register Hooks, 6 x 6 ems.....each, \$1.00
Steel Keys, 2-inch.....each, .05
Steel Keys, 4-inch, double end.....each, .20

QUICKEST REGISTER HOOK

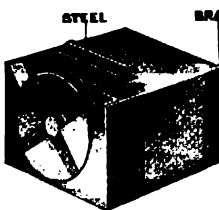

Especially designed for book work where it is desirable to change from one plate to another quickly. One turn of the key moves the clutch far enough to release the plate.

Made from solid brass. Clutch and screw of steel. Slotted head of steel, tempered.

Quickest Register Hooks, 6 x 6 ems.....each, \$1.00
Steel Keys, 2-inch.....each, .05
Steel Keys, 4-inch, double end.....each, .20

KYLE REGISTER HOOK

Designed for narrowest possible margins. Plates can be placed within eight points of each other. Made from solid brass, clutch screw and nut of steel.

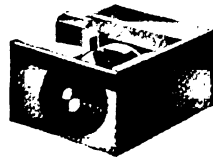

Kyle Register Hooks, 6 x 6 ems. (right or left)....each, \$1 10
Steel Keys, 2-inch.....each, .05
Steel Keys, 4-inch, double end.....each, .20

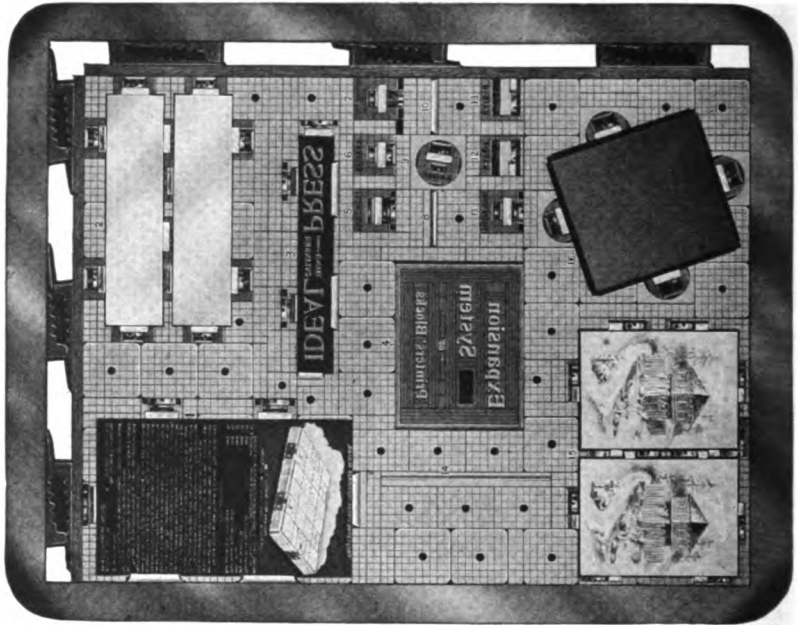

Cut Showing Sectional Blocks and Register Hooks in Use

SWIVEL REGISTER HOOK

Made from solid steel and brass. The center portion is the well-known Eureka Register Hook so mounted that it will turn in any direction even after being locked up in form. By use of these hooks an irregular plate can be held perfectly or any plate can be placed at any desired angle in the form.

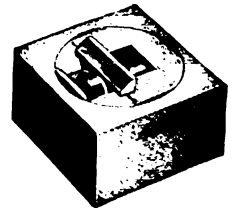

Swivel Register Hooks, 8 x 8 ems.....each, \$1.50
Steel Keys, 2-inch.....each, .05
Steel Keys, 4-inch, double end.....each, .20

BRASS CATCHES

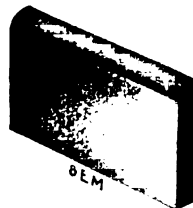

1 x 4 ems, Brass Catches, each, \$0.10
1 x 6 ems, Brass Catches, each, .12
1 x 8 ems, Brass Catches, each, .15
1 x 16 ems, Brass Catches, each, .25

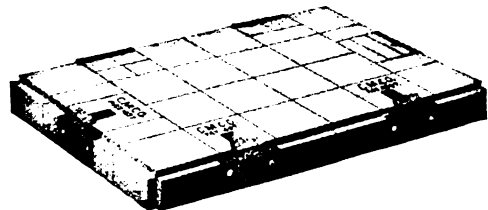

CHALLENGE METAL SECTIONAL BLOCKS
or the "Expansion System of Printers' Blocks."

Challenge Metal Sectional Blocks, hard metal, sizes 16 x 16, 8 x 16, 8 x 8, 4 x 8, 2 x 8, 2 x 6, 2 x 4, 1 x 8, 1 x 6 and 1 x 4 ems..... per pound, \$0.25
Mahogany Sections, 8 ems square.....each, .10



PATENT IRON GROOVED BLOCK

This is a block that will completely meet all the requirements of those who print from flat plates. It is made from solid iron three-quarters of an inch thick (unless otherwise ordered), and is made flush all round. It is lined over its entire surface in squares of one 12-point em, the grooves being cut diagonally across the block one inch apart. The blocks are usually made two inches larger each way than the largest form that can be printed on the press for which the block is required. Blocks larger than 20 x 25 inches are made in two or four sections at no extra charge. The sections are accurately fitted together with dowel pins and each section may be used as an independent block.

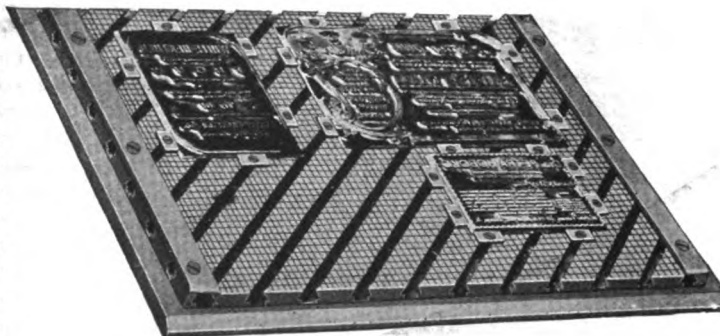

Patent Grooved Blocks are made to order only. In ordering, send us the name of the press for which a block is required, with the exact bed measurements and the narrowest margins required. Write for net prices.

LABOR-SAVING IRON FURNITURE



This furniture is all made on the point system, in regular labor saving sizes; is micro-ground and therefore absolutely accurate. It cannot be dented or bruised and will not expand in stereotyping and afterwards contract out of shape, but will keep its proper form under the most severe locking or heating. It has a permanent value as it is practically indestructible. It is much lighter than metal furniture. Where close register is required, as in three-color work, this furniture is especially valuable on account of its great accuracy and rigidity.

- Font A—12 pieces each 3, 4 and 5 x 5, 3, 4, 5 and 6 x 6, 3, 4, 5, 6 and 8 x 8, 3, 4, 5, 6, 8 and 10 x 10, 3, 4, 5, 6, 8, and 10 x 15, 3 and 4 x 20; 8 each of 5, 6, 8 and 10 x 20, 3, 4, 5, 6, 8 and 10 x 25. 392 pieces.....\$32.00
- Font B—12 pieces each 2 x 4, 2, 3, 4 and 5 x 5, 2, 3, 4, 5 and 6 x 6, 2, 3, 4, 5, 6 and 8 x 8, 2, 3, 4, 5, 6, 8 and 10 x 10, 2, 3, 4, 5, 6, 8 and 10 x 15, 2, 3 and 4 x 20, 2 x 25; 8 each 5, 6, 8 and 10 x 20, 3, 4, 5, 6, 8 and 10 x 25. 488 pieces.....\$37.00
- Font C—16 pieces each 3, 4, 5, 6, 8 and 10 x 15, 3, 4, 5, 6, 8 and 10 x 20, 3, 4, 5, 6, 8 and 10 x 25. 288 pieces.....\$32.00
- Font D—16 pieces each 2, 3, 4, 5, 6, 8 and 10 x 15, 3, 4, 5, 6, 8 and 10 x 20, 3, 4, 5, 6, 8 and 10 x 25. 336 pieces....\$37.00
- Font E—36 pieces each 2, 3 and 4 x 4, 2, 3 and 4 x 5, 2, 3 and 4 x 6; 28 pieces each 2, 3 and 4 x 8, 2, 3 and 4 x 12; 16 pieces each 2, 3 and 4 x 16, 2, 3 and 4 x 20. 588 pieces.....\$32.00
- Font F—28 pieces each 2, 3 and 4 x 4, 2, 3 and 4 x 5, 2, 3 and 4 x 6, 2, 3 and 4 x 8, 2, 3 and 4 x 12, 2, 3 and 4 x 16, 2, 3 and 4 x 20. 588 pieces.....\$32.00
- Font G—One-half size of Font A.....\$16.00
- Font H—One-half size of Font B..... 18.50
- Font I—One-half size of Font C..... 16.00
- Font J—One-half size of Font D..... 18.50
- Font K—One-half size of Font E..... 16.00
- Font L—One-half size of Font F..... 16.00
- Font M—One-fourth size of Font A.....\$ 8.50
- Font N—One-fourth size of Font B..... 10.00
- Font O—One-fourth size of Font C..... 8.50
- Font P—One-fourth size of Font D..... 10.00
- Font Q—One-fourth size of Font E..... 8.50
- Font R—One-fourth size of Font F..... 8.50

COMBINATION PAPER JOGGER

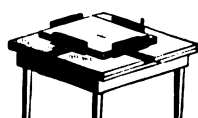

These Joggers will save the price they cost from one to four times a year. It will take a good man two hours, or more to even the paper from one day's output of a press, to say nothing of the sheets that are torn on the edges by handling uneven paper. In ordering, always give size of largest sheet you want to print. If your table is fitted to the press, give accurate measurement of the same. State the kind of press.

- 24 x 36 or less.....\$15.00
- 36 x 48 or less..... 18.00
- Larger than 36 x 48..... 20.00

TYPE-HIGH GAUGE



This gauge saves an immense amount of time; with it you can put a gauge on work sent in by electrotypers and engravers thus enabling you to correct the height of cuts and electrotypes before they are sent to the press room, thereby avoiding delay and saving valuable time which, otherwise, is a total loss because unnecessary.

Price, \$1.50

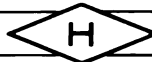

PATENT STEEL FURNITURE

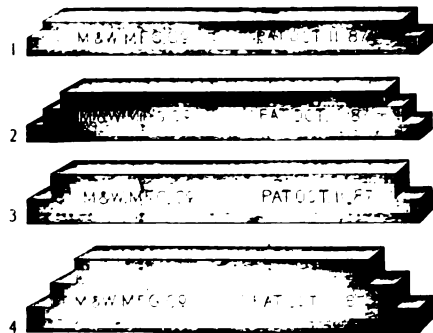

Invaluable for blank work. Accurately cut on the point system. One of the greatest labor savers ever introduced. In use in most of the large offices in this country and Great Britain.

Patent Steel Furniture is a well-tryed and useful device for saving time in making up and locking up printing forms. It consists of pieces of steel in accurate lengths with notched ends, which can be quickly thrown around blank spaces, instead of filling in the ordinary way with wood or metal furniture. As it takes less material to go around a space than to fill

it, so it takes less time to do it. For color and blank work it is unequalled.

Pieces of first and second styles work together, and pieces of the third and fourth.

Made of 24, 36, or 54-point steel $\frac{1}{8}$ of an inch high, and with either 12 or 18 point notches. Accurate in every way to the one-thousandth of an inch. It is not only practically perfect when new, but being made of steel it is always accurate.

STYLES AND PRICES

Font A—The lengths from 8 to 42 are of 24-point steel, with 12-point notch, namely: 8, 10, 12, 14, 16, 18, 20, 22, 24, 26, 28, 30, 32, 34, 36, 38, 40 and 42 picas. The lengths from 45 to 72 are of 36-point steel, with two 12-point notches, namely: 45, 48, 51, 54, 57, 60, 63, 66, 69 and 72 picas. Total—28 different lengths, eight pieces of each, 224 in all..... Price, \$54.00

Font B—Has half the quantity of Font A..... Price, \$27.00

Font C—Is the 24-point stock only of Font A, 8 pieces each, 8 to 42 ems, 144 pieces in all..... Price, \$29.00

Font D—Has half the quantity of Font C..... Price, \$14.50

Font E—Is the 36-point stock of Font A, 8 pieces each, 45 to 72 ems, 80 pieces in all..... Price, \$25.00

Font F—Has half the quantity of Font E..... Price, \$12.50

Font G—Is made entirely of 36-point steel, with one 18-point notch, as per Style Number Three, and runs in length from 9 to 72 picas, varying by 3 picas, namely: 9, 12, 15, 18, 21, 24, 27, 30, 33, 36, 39, 42, 45, 48, 51, 54, 57, 60, 63, 66, 69, 72 picas. Total—22 lengths, 8 pieces each, 176 in all..... Price, \$44.00

Font H—Has half the quantity of Font G..... Price, \$22.00

Font I—Is made of 54-point steel, with two 18-point notches, as per Style Number Four, the lengths being 15, 18, 21 and 24 inches, there being four outside pieces and two cross bars for each length, or 24 pieces in all. The outside pieces are notched to receive the cross bars, which are halved together..... Price, \$21.00

Font J—The lengths from 6 to 30 are of 24-point steel, with 12-point notch, namely: 6, 8, 10, 12, 14, 16, 18, 20, 22, 24, 26 and 30 picas. From 33 to 60 it is 36-point steel, with two 12-point notches, namely: 33, 36, 39, 42, 45, 48, 51, 54, 57 and 60 picas. From 63 to 72 it is 48-point steel, with three 12-point notches, namely: 63, 66, 69 and 72 picas. Total—27 different lengths, 8 pieces of each, 216 in all..... Price, \$58.00

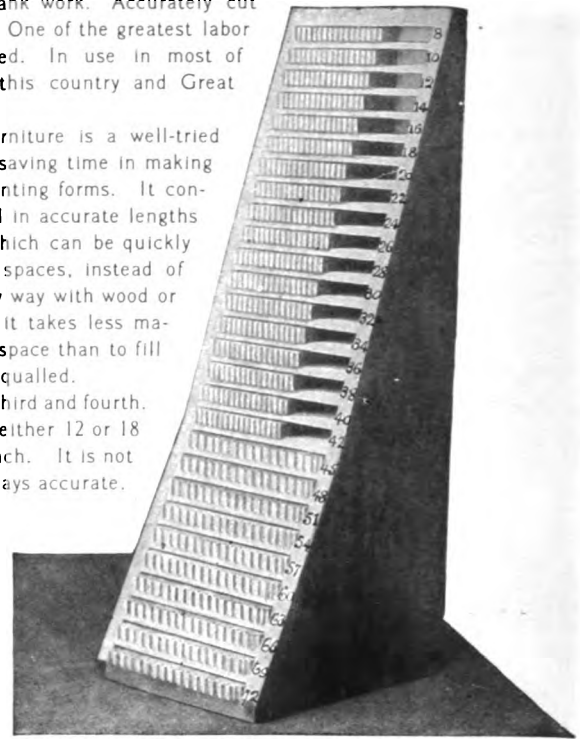

Double Font "A" in Case

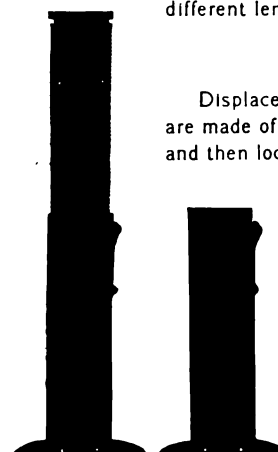

Slanson Patent Locks Open and Closed

SLANSON PATENT CYLINDER PRESS LOCKS

Displace furniture and quoins in locking up forms in chases and on the beds of cylinder presses. They are made of flat drawn steel tubes, which telescope one into another and are drawn out to fill a given space and then locked by an ordinary Hempel key. The quoin, which is in the form of a coil or snail, has an extension of two picas and is absolutely safe. The parts are dropped steel forgings. The locks themselves are practically indestructible. They are invaluable on beds of cylinder presses where forms are being locked that are smaller than the beds. They are almost as quick as a flash and they hold the form solid to the bed, taking out the spring of a chase and preventing the working up of material inside.

Made in five sizes and sold in pairs at net prices as follows:

3 inches when shut, opening to 5 inches.....	Price, per pair, \$4.50
5 " " " " " 8 "	" " " 4.50
8 " " " " " 14 "	" " " 5.50
14 " " " " " 26 "	" " " 6.50
22 " " " " " 36 "	" " " 8.00

Complete Set, \$29.00

Wall Pocket for holding a set, \$0.50

THE H. C. HANSEN TYPE FOUNDRY



STERLING ROUND CORNERING MACHINE

This machine is for round cornering booklets, catalogs, cards of all kinds, labels, folders, calendar backs, and an endless variety of other work. It is the most popular machine for the purpose ever devised, and over 6,000 of them have already been sold. The machine is self-clamping and very rapid. Every part is made with the utmost care.

The price is \$15.00, including one knife of the size generally used, but we have four other styles at \$1.25 each.

The operation of the Sterling is so simple and the price so low that no enterprising concern can afford to get along without one of these wonderful machines.

SOME OF THE STERLING ATTACHMENTS

The Sterling is like the "Elastic Book Case" always complete but never finished. We illustrate the Pedestal Foot Power Attachment on which the Sterling can be mounted in a few minutes, allowing the operator use of both hands for guiding the stock. The price of this attachment is only \$15.00. It increases the utility of the machine to a very great extent.

We also illustrate the Perforating Attachment which can be added to any Sterling Machine. The gauges can be instantly adjusted for handling any particular size or shape of

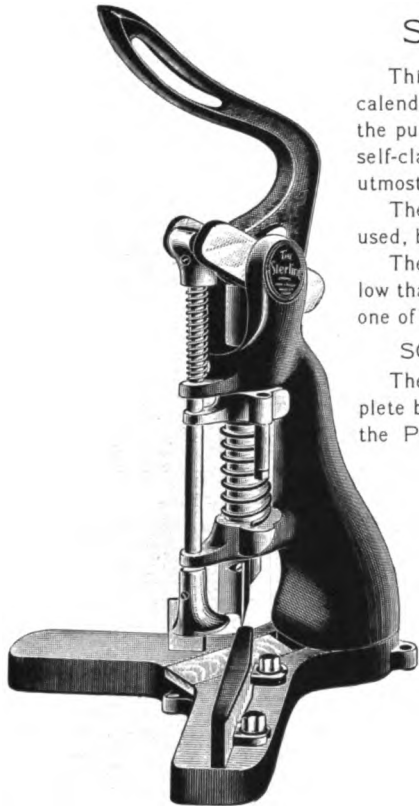

Sterling Round Cornering Machine

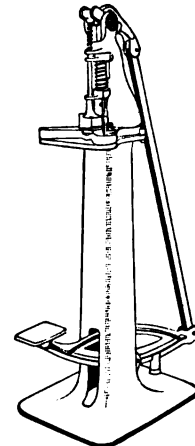

Sterling Pedestal Foot Power Attachment

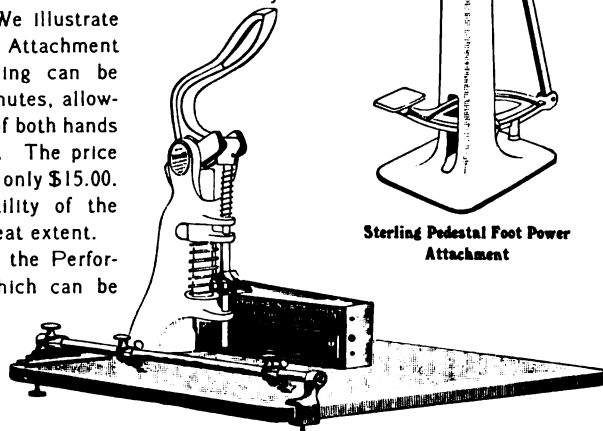

Sterling Perforating Attachment

work, and adjustments can be made to the hundredth part of an inch. This attachment costs \$18.00, and when added to a Sterling you will have the best 10-inch perforator on the market.

Space will not permit us to show the other attachments for punching of all kinds, including the loose leaf and card index work, eyeletting, stabbing, etc.

We shall be glad to send you a special illustrated catalog regarding the Sterling and what it will do.

Sterling Round Cornering Machine, hand power.....	\$15.00
Pedestal Foot Power Attachment, additional.....	15.00
Stabbing Attachment	5.00
Loose Leaf Punching Attachment	12.00
Perforating Attachment	18.00
Punching Attachment	10.00

BROWER ROLLING GALLEY RACK

The Rolling Galley Rack costs but little more, capacity considered, than the ordinary wall galley rack, and is much more convenient and economical. The racks loaded with galleys and type can be transferred from the composing room to the make-up tables, and when not in actual use they can be pushed aside into out of the way corners. They are mounted on heavy 2½-inch double casters with wheel bearings, capable of sustaining a weight of 2,000 pounds. Uprights have drop handles. The base is wide, thus insuring against accident by capsizing. The woodwork is of hardwood nicely finished. The brackets are detachable and reversible. When reversed the galleys are held in a horizontal position.

No. 1 holds 30 galleys, is 66 inches high.....	List price, \$20.00
No. 2 holds 20 galleys, is 49 inches high.....	List price, 17.00
No. 3 holds 16 galleys, is 42 inches high.....	List price, 15.00

Prices are for racks complete with 8-inch brackets, which take standard double column galleys. 10- and 12-inch brackets can be supplied. Prices on application.

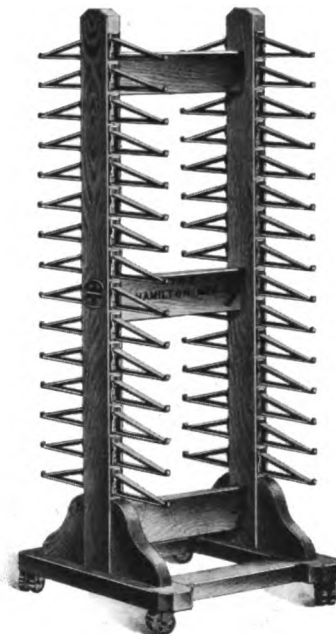

Brower Rolling Galley Rack

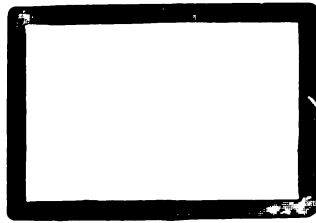

Skeleton Chase

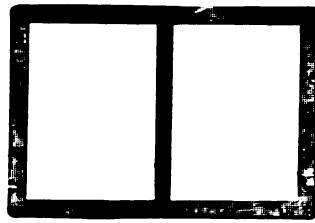

News Chase

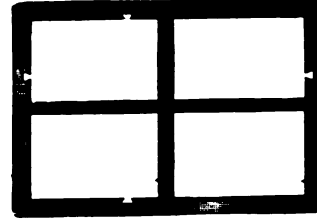

Book Chase with Shifting Bar

ELECTRIC WELDED CHASES

PRICE LIST AND SIZES

No.	Length and Breadth. (Ins.)	Outside Measure of Chase.	Inside Measure of Chase.	Skeleton Chase.	News Chase.	Book Chase, Both Bars Shifting.	No.	Size of Pair Over all.	Size of Each Half, Inside.	Folio Chase.	Quarto Chase.
21	38	17 X 20%	14 1/2 X 18%	\$4 50	\$6 50	\$10 50	21 17	X 20%	14 1/2 X 8 1/2	\$9 00	\$12 00
22	39	17 X 21%	14 1/2 X 19%	4 50	6 50	10 50	22 17	X 21%	14 1/2 X 9	9 00	12 00
23	45	20 X 24%	17 X 22 1/2	4 95	6 95	10 95	23 20	X 24%	17 X 10 1/2	9 00	12 00
24	49	22 X 26%	19 X 24 1/2	5 40	7 40	11 40	24 22	X 26%	19 X 11 1/2	9 30	12 00
25	53	24 X 28%	21 X 26 1/2	5 85	7 85	11 85	25 24	X 28%	21 X 12 1/2	10 05	12 00
26	54	24 X 29%	21 X 27 1/2	5 95	7 95	11 95	26 24	X 29%	21 X 12 1/2	10 25	12 00
27	55	25 X 29%	22 X 27 1/2	6 05	8 05	12 05	27 25	X 29%	22 X 12 1/2	10 45	12 10
28	56	25 X 30%	22 X 28 1/2	6 15	8 15	12 15	28 25	X 30%	22 X 13 1/2	10 65	12 30
29	57	26 X 30%	23 X 28 1/2	6 25	8 25	12 25	29 26	X 30%	23 X 13 1/2	10 85	12 35
30	58	26 X 31%	23 X 29 1/2	6 40	8 40	12 40	30 26	X 31%	23 X 13 1/2	11 00	12 75
31	58	27 X 30%	24 X 28 1/2	6 40	8 40	12 40	31 27	X 30%	24 X 13 1/2	11 00	12 75
32	60	25 X 34%	22 X 32 1/2	6 60	8 60	12 60	32 25	X 34%	22 X 15 1/2	11 40	13 20
33	60	26 X 33%	23 X 31 1/2	6 60	8 60	12 60	33 26	X 33%	23 X 14 1/2	11 40	13 20
34	62	25 1/2 X 35%	23 1/2 X 33 1/2	6 80	8 80	12 80	34 25 1/2	X 35%	23 1/2 X 15 1/2	11 80	13 65
35	62	26 X 35%	23 1/2 X 33 1/2	6 80	8 80	12 80	35 26	X 35%	23 1/2 X 15 1/2	11 80	13 65
36	63	26 X 36%	23 1/2 X 34 1/2	6 95	8 95	12 95	36 26	X 36%	23 1/2 X 16 1/2	11 95	13 85
37	63	28 X 34%	25 1/2 X 32 1/2	6 95	8 95	12 95	37 28	X 34%	25 1/2 X 15 1/2	11 95	13 85
38	65	27 X 37%	24 1/2 X 35 1/2	7 15	9 15	13 15	38 27	X 37%	24 1/2 X 16 1/2	12 35	14 30
39	66	27 X 38%	24 1/2 X 36 1/2	7 25	9 25	13 25	39 27	X 38%	24 1/2 X 17 1/2	12 55	14 50
40	67	27 X 39%	24 1/2 X 37 1/2	7 35	9 35	13 35	40 27	X 39%	24 1/2 X 17 1/2	12 75	14 75
41	70	28 1/2 X 40%	26 X 38 1/2	7 70	9 70	13 70	41 28 1/2	X 40%	26 X 18 1/2	13 30	15 40
42	71	29 X 41%	26 1/2 X 39 1/2	7 80	9 80	13 80	42 29	X 41%	26 1/2 X 18 1/2	13 50	15 60
43	72	29 1/2 X 41%	27 1/2 X 39 1/2	7 90	9 90	13 90	43 29 1/2	X 41%	27 1/2 X 18 1/2	13 70	15 85
44	72	29 X 42%	26 1/2 X 40 1/2	7 90	9 90	13 90	44 29	X 42%	26 1/2 X 19 1/2	13 70	15 85
45	72	30 X 41%	27 1/2 X 39 1/2	7 90	9 90	13 90	45 30	X 41%	27 1/2 X 18 1/2	13 70	15 85
46	74	31 X 42%	28 1/2 X 40 1/2	8 15	10 15	14 15	46 31	X 42%	28 1/2 X 19 1/2	14 05	16 30
47	76	33 X 42%	30 1/2 X 40 1/2	8 35	10 35	14 35	47 33	X 42%	30 1/2 X 19 1/2	14 45	16 70
48	76	32 X 43%	29 1/2 X 41 1/2	8 35	10 35	14 35	48 32	X 43%	29 1/2 X 19 1/2	14 45	16 70
49	77	29 X 47%	26 1/2 X 45 1/2	8 45	10 45	14 45	49 29	X 47%	26 1/2 X 21 1/2	14 65	16 95
50	78	32 X 45%	29 1/2 X 43 1/2	8 60	10 60	14 60	50 32	X 45%	29 1/2 X 20 1/2	14 80	17 15
51	79	32 X 46%	29 1/2 X 44 1/2	8 70	10 70	14 70	51 32	X 46%	29 1/2 X 21 1/2	15 00	17 40
52	79	34 X 44%	31 1/2 X 42 1/2	8 70	10 70	14 70	52 34	X 44%	31 1/2 X 20 1/2	15 00	17 40
53	80	33 1/2 X 45%	31 X 43 1/2	8 80	10 80	14 80	53 33 1/2	X 45%	31 X 20 1/2	15 20	17 60
54	80	33 X 46%	30 1/2 X 44 1/2	8 80	10 80	14 80	54 33	X 46%	30 1/2 X 21 1/2	15 20	17 60
55	80	34 X 45%	31 1/2 X 43 1/2	8 80	10 80	14 80	55 34	X 45%	31 1/2 X 20 1/2	15 20	17 60
56	81	33 1/2 X 46%	30 3/4 X 44	8 90	10 90	14 90	56 33 1/2	X 46%	30 3/4 X 21 1/2	15 40	17 80
57	81	33 X 47%	30 1/4 X 45	8 90	10 90	14 90	57 33	X 47%	30 1/4 X 21 1/2	15 40	17 80
58	81	35 X 45%	32 1/4 X 43	8 90	10 90	14 90	58 35	X 45%	32 1/4 X 20 1/2	15 40	17 80
59	82	33 1/2 X 47%	30 3/4 X 45	9 00	11 00	15 00	59 33 1/2	X 47%	30 3/4 X 21 1/2	15 60	18 05
60	82	32 X 49%	29 1/4 X 47	9 00	11 00	15 00	60 32	X 49%	29 1/4 X 22 1/2	15 60	18 05
61	82	34 X 47%	31 1/4 X 45	9 00	11 00	15 00	61 34	X 47%	31 1/4 X 21 1/2	15 60	18 05
62	82	35 X 46%	32 1/4 X 44	9 00	11 00	15 00	62 35	X 46%	32 1/4 X 21 1/2	15 60	18 05
63	83	33 1/2 X 48%	30 3/4 X 46	9 15	11 15	15 15	63 33 1/2	X 48%	30 3/4 X 22 1/2	15 75	18 25
64	84	33 1/2 X 49%	30 3/4 X 47	9 25	11 25	15 25	64 33 1/2	X 49%	30 3/4 X 22 1/2	15 95	18 50
65	84	34 X 49%	31 1/4 X 47	9 25	11 25	15 25	65 34	X 49%	31 1/4 X 22 1/2	15 95	18 50
66	84	36 X 47%	33 1/4 X 45	9 25	11 25	15 25	66 36	X 47%	33 1/4 X 21 1/2	15 95	18 50
67	85	34 1/2 X 49%	31 3/4 X 47	9 35	11 35	15 35	67 34 1/2	X 49%	31 3/4 X 22 1/2	16 15	18 70
68	85	35 X 49%	32 1/4 X 47	9 35	11 35	15 35	68 35	X 49%	32 1/4 X 22 1/2	16 15	18 70

* The figures in this column represent the combined length and breadth of each chase; fractions being taken as one inch.
 † For Book Chases with one bar shifting, deduct \$1.00 from list price of all sizes; for Book Chases with bars stationary, deduct \$2.00 from list price of all sizes.

Chases for All Makes of Job Presses Prices on application

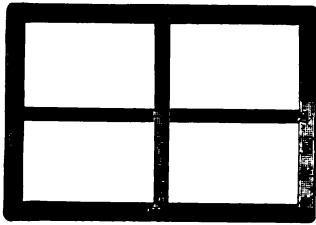

Book Chase with Stationary Bars

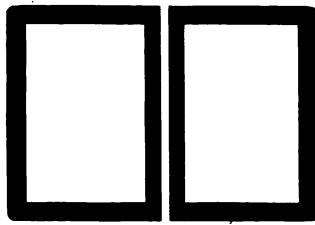

Folio Chase

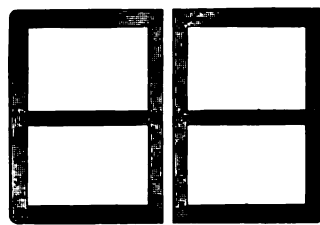

Quarto Chase

ELECTRIC WELDED CHASES
PRICE LIST AND SIZES

No.	* Length and Breadth (Ins.)	Outside Measure of Chase.	Inside Measure of Chase.	Skeleton Chase.	News Chase.	† Book Chase, Both Bars Shifting.	No.	Size of Pair, Over all.	Size of Each Half, Inside.	Folio Chase.	Quarto Chase.
69	85	37 X 47%	34 1/4 X 45	\$9 35	\$11 85	\$15 35	69	37 X 47%	34 1/4 X 21 1/4	\$16 15	\$18 70
70	86	35 X 50%	32 1/4 X 48	9 45	11 45	15 45	70	35 X 50%	32 1/4 X 23 1/4	16 35	18 90
71	87	36 X 50%	33 1/4 X 48	9 55	11 55	15 55	71	36 X 50%	33 1/4 X 23 1/4	16 55	19 15
72	88	36 X 51%	33 1/4 X 49	9 70	11 70	15 70	72	36 X 51%	33 1/4 X 23 1/4	16 70	19 35
73	88	37 X 50%	34 1/4 X 48	9 70	11 70	15 70	73	37 X 50%	34 1/4 X 23 1/4	16 70	19 35
74	89	37 1/4 X 50%	34 1/4 X 48	9 80	11 80	15 80	74	37 1/4 X 50%	34 1/4 X 23 1/4	16 90	19 60
75	89	37 X 51%	34 1/4 X 49	9 80	11 80	15 80	75	37 X 51%	34 1/4 X 23 1/4	16 90	19 60
76	89	38 X 50%	35 1/4 X 48	9 80	11 80	15 80	76	38 X 50%	35 1/4 X 23 1/4	16 90	19 60
77	91	38 1/4 X 51%	35 1/4 X 49	10 00	12 00	16 00	77	38 1/4 X 51%	35 1/4 X 23 1/4	17 30	20 00
78	91	37 X 53%	34 1/4 X 51	10 00	12 00	16 00	78	37 X 53%	34 1/4 X 24 1/4	17 30	20 00
79	91	39 X 51%	36 1/4 X 49	10 00	12 00	16 00	79	39 X 51%	36 1/4 X 23 1/4	17 30	20 00
80	92	38 1/4 X 52%	35 1/4 X 50	10 10	12 10	16 10	80	38 1/4 X 52%	35 1/4 X 24 1/4	17 50	20 25
81	92	39 1/4 X 51%	36 1/4 X 49	10 10	12 10	16 10	81	39 1/4 X 51%	36 1/4 X 23 1/4	17 50	20 25
82	92	38 X 53%	35 1/4 X 51	10 10	12 10	16 10	82	38 X 53%	35 1/4 X 24 1/4	17 50	20 25
83	92	39 X 52%	36 1/4 X 50	10 10	12 10	16 10	83	39 X 52%	36 1/4 X 24 1/4	17 50	20 25
84	93	38 3/4 X 53%	36 X 51	10 25	12 25	16 25	84	38 3/4 X 53%	36 X 24 1/4	17 65	20 45
85	93	38 X 54%	35 1/4 X 52	10 25	12 25	16 25	85	38 X 54%	35 1/4 X 25 1/4	17 65	20 45
86	94	38 1/4 X 54%	35 1/4 X 52	10 35	12 35	16 35	86	38 1/4 X 54%	35 1/4 X 25 1/4	17 85	20 70
87	94	39 1/4 X 54%	36 1/4 X 52	10 35	12 35	16 35	87	39 1/4 X 54%	36 1/4 X 25 1/4	17 85	20 70
88	94	40 X 53%	37 1/4 X 51	10 35	12 35	16 35	88	40 X 53%	37 1/4 X 24 1/4	17 85	20 70
89	96	39 X 56%	36 1/4 X 54	10 55	12 55	16 55	89	39 X 56%	36 1/4 X 26 1/4	18 25	21 10
90	96	41 X 54%	38 1/4 X 52	10 55	12 55	16 55	90	41 X 54%	38 1/4 X 25 1/4	18 25	21 10
91	97	39 1/4 X 57%	36 1/4 X 54 1/2	10 65	12 65	16 65	91	39 1/4 X 57%	36 1/4 X 26 1/4	18 45	21 35
92	98	42 1/4 X 54%	39 1/4 X 52	10 80	12 80	16 80	92	42 1/4 X 54%	39 1/4 X 25 1/4	18 60	21 55
93	99	43 X 55%	40 1/4 X 53	10 90	12 90	16 90	93	43 X 55%	40 1/4 X 25 1/4	18 80	21 80
94	100	43 X 56%	40 1/4 X 54	11 00	13 00	17 00	94	43 X 56%	40 1/4 X 26 1/4	19 00	22 00
95	101	41 X 59%	38 X 56%	11 10	13 10	17 10	95	41 X 59%	38 X 27 1/4	19 20	22 20
96	101	43 1/4 X 57%	40 1/2 X 54 1/2	11 10	13 10	17 10	96	43 1/4 X 57%	40 1/2 X 26 1/4	19 20	22 20
97	102	42 X 59%	39 X 56%	11 20	13 20	17 20	97	42 X 59%	39 X 27 1/4	19 40	22 45
98	103	43 X 59%	40 X 56%	11 35	13 35	17 35	98	43 X 59%	40 X 27 1/4	19 55	22 65
99	104	43 X 60%	40 X 57%	11 45	13 45	17 45	99	43 X 60%	40 X 27 1/4	19 75	22 90
100	104	44 X 59%	41 X 56%	11 45	13 45	17 45	100	44 X 59%	41 X 27 1/4	19 75	22 90
101	105	43 X 61%	40 X 58%	11 55	13 55	17 55	101	43 X 61%	40 X 28 1/4	19 95	23 10
102	105	45 X 59%	42 X 56%	11 55	13 55	17 55	102	45 X 59%	42 X 27 1/4	19 95	23 10
103	106	46 X 59%	43 X 56%	11 65	13 65	17 65	103	46 X 59%	43 X 27 1/4	20 15	23 30
104	107	46 1/4 X 59%	43 1/2 X 56%	11 75	13 75	17 75	104	46 1/4 X 59%	43 1/2 X 27 1/4	20 35	23 55
105	107	45 X 61%	42 X 58%	11 75	13 75	17 75	105	45 X 61%	42 X 28 1/4	20 35	23 55
106	107	47 X 59%	44 X 56%	11 75	13 75	17 75	106	47 X 59%	44 X 27 1/4	20 35	23 55
107	108	45 1/2 X 61%	42 1/2 X 58%	11 90	13 90	17 90	107	45 1/2 X 61%	42 1/2 X 28 1/4	20 50	23 75
108	108	45 X 62%	42 X 59%	11 90	13 90	17 90	108	45 X 62%	42 X 28 1/4	20 50	23 75
109	108	47 X 60%	44 X 57%	11 90	13 90	17 90	109	47 X 60%	44 X 27 1/4	20 50	23 75
110	108	48 X 59%	45 X 56%	11 90	13 90	17 90	110	48 X 59%	45 X 27 1/4	20 50	23 75
111	109	46 1/2 X 61%	43 1/2 X 58%	12 00	14 00	18 00	111	46 1/2 X 61%	43 1/2 X 28 1/4	20 70	24 00
112	110	50 X 59%	47 X 56%	12 10	14 10	18 10	112	50 X 59%	47 X 27 1/4	20 90	24 20
113	111	45 1/2 X 64%	42 1/2 X 61%	12 20	14 20	18 20	113	45 1/2 X 64%	42 1/2 X 29 1/4	21 10	24 40
114	112	47 X 64%	44 X 61%	12 30	14 30	18 30	114	47 X 64%	44 X 29 1/4	21 30	24 65
115	116	48 X 67%	45 X 64%	12 75	14 75	18 75	115	48 X 67%	45 X 31 1/4	22 05	25 50
116	118	48 1/2 X 68%	45 1/2 X 65%	13 00	15 00	19 00	116	48 1/2 X 68%	45 1/2 X 31 1/4	22 40	25 95

* The figures in this column represent the combined length and breadth of each chase; fractions being taken as one inch.
† For Book Chases with one bar shifting, deduct \$1.00 from list price of all sizes; for Book Chases with bars stationary deduct \$2.00 from list price of all sizes.

Electrotype Chases. 6 x 8, \$1.00. 7 x 9, \$1.25. 9 1/2 x 11 1/2, \$1.75. 9 1/2 x 14, \$2.00 10 x 14, \$2.25 12 1/2 x 18, \$2.75

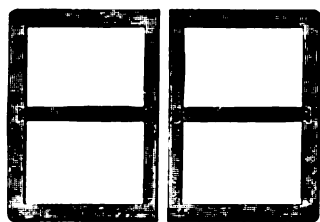

Newspaper Folio Chases

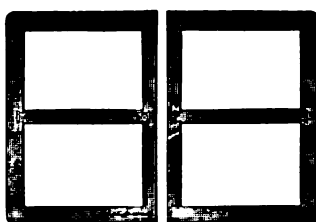

Newspaper Quarto Chases

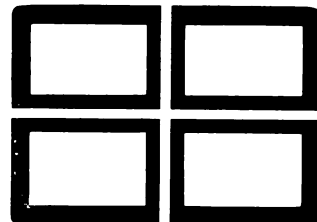

Quarto Chases

ELECTRIC WELDED CHASES

Newspaper Chases, Folio

Two sizes of chases for each standard size of newspaper are given, the smaller for use where the bed measurement of press limits size of chase, the larger size for use where the bed offers ample room for lock-up.

No.	Size of Paper.	Size of Pair, over all.	Size Each Half, Inside.	Width of Backs.	Size of Iron.	Price per Pair.
1	5-Column	21¾×28	12½ ×19%	1¾	1½×%	\$9 50
*2	5-Column	22¼×29%	12¾×20½	1¾	1½×%	9 90
3	6-Column	24 ×32½	14% ×21½	1¾	1½×%	10 85
*4	6-Column	24 ×33%	15 ×21¾	1¾	1½×%	11 00
5	7-Column	25¼×38	17¼ ×23½	1¾	1½×%	12 15
*6	7-Column	26 ×38%	17½×23%	1¾	1½×%	12 35
7	7×6-Column	24 ×38%	17½ ×21%	1¾	1½×%	11 95
8	8-Column	28 ×42	18¾×25½	1¾	1½×%	13 30
*9	8-Column	28¼×43%	19% ×25%	1¾	1½×%	13 70
10	9-Column	30½×47	21½×28	1¾	1½×%	14 80
11	9-Column	30¼×48%	22 ×27%	1¾	1½×%	15 00
12	For Paper 24×36	26¼×40	14½×24	1¾	1½×%	12 75

* These measures allow for 13 ems pica columns and 7-point column rules, except for 9-column paper, when 8-point rules are used, allowing 1¾ ins. for lock-up.

Newspaper Chases, Quarto

Two sizes of chases for each standard size of newspaper are given, the smaller size for use where the bed measurement of press limits size of chase, the larger size for use where the bed measurement allows ample room for lock-up.

No.	Size of Paper.	Size of Pair, over all.	Size, Each Half, Inside.	Width of Backs.	Width of Bar.	Size of Iron.	Price per Pair.
*1	4-Column	24¼×35%	16¼×22%	1¾	1	1½×%	\$13 40
2	4-Column	24½×36	16% ×22%	1¾	1	1½×%	13 40
3	5-Column	28½×43	19¾×26¼	1¾	1	1½×%	15 85
*4	5-Column	29½×44½	20½×27¼	1¾	1	1½×%	16 30
5	6-Column	32½×46	20¾×30	1¾	1	1½×%	17 40
6	6-Column	32½×47	21¾×30	1¾	1	1½×%	17 60
*7	6-Column	34 ×47%	21¾ ×31½	1¾	1	1½×%	18 05
8	7-Column	37½×51	23¼ ×34%	1¾	1	1½×%	19 60
*9	7-Column	39 ×52%	23¾×36%	1¾	1	1½×%	20 25
*10	8-Column	43½×56½	25¾×40%	1¾	1	1½×%	22 00

* These measurements allow for 13 ems pica columns and 7-point column rules, except for 9-column paper, when 8-point column rules are used, allowing 1¾ ins. for lock-up.

Quadruple Chases

No.	Size of Paper.	Size of Set, over all.	Size Each Chase, Outside.	Size Each Chase, Inside.	Width of Backs.	Size of Iron.	Price per Set of Four.
1	5-Column	28 ×42½	14 ×21¼	12½ ×19%	1¾	1½×%	\$19 90
1a	5-Column	29¼×42%	14% ×21¾	12¾×19½	1¾	1½×%	20 45
2	6-Column	32½×47	16¼ ×23½	14¾×21¾	1¾	1½×%	22 40
2a	6-Column	33%×46%	16¾×23¾	14% ×21½	1¾	1½×%	22 70
3	7-Column	38 ×50½	19 ×25¼	16¾×22¾	1¾	1½×%	24 90
3a	7-Column	38%×51%	19% ×25½	17% ×23½	1¾	1½×%	25 20

Unless otherwise specified we will supply the 1a, 2a, and 3a sets. They are designed to accommodate standard size pages, made up of 13-em matter, with 7-point column rules. With side and foot sticks 5/8 x 3/8 in., No. 2 Hempel or Keystone Quoins can be used; with side and foot sticks 3/4 x 5/8 in., No. 1 Hempel or Keystone Quoins can be used.

To ascertain list prices of other sizes of Quadruple Cases, add length and breadth in inches of set over all, and multiply by 28 cents per inch.

Heading Chases. 6x17, \$4.50 8x21, \$4.50. 8x28, \$4.50. Cross Bars \$2.00 extra. Other sizes to order.



No. 8 Benzine Brush



No. 5 Benzine Brush

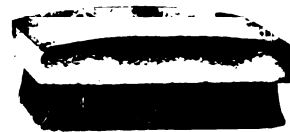

No. 4 Benzine Brush

BENZINE AND LYE BRUSHES

No. 4 Benzine Brush, all bristle, size 2½ x 4½ inches, convex back..... each \$0.50 per doz. \$5.00	No. 4823 Benzine Brush, goat hair, size 2½ x 5½ inches, convex back.....each \$0.60 per doz. \$6.50
No. 6 Benzine Brush, mane hair, size 2½ x 6½ inches, rounded ends.....each \$0.40 per doz. 4.00	Boston Benzine Brush, plush surface, size 2½ x 6 inches.....each .25
No. 5 Benzine Brush with handle, white bristle, size 1 x 11½ over all, 6-inch handle..each \$0.35 per doz. 3.75	No. 4330 Lye Brush, white Tampico, 3 x 8½ inches... each \$0.25 per doz. 2.50
No. 7 Benzine Brush, Jap. bristle, size 2½ x 8½ inches each \$1.00 per doz. 10.50	No. 1 Lye Brush, size 3 x 9 inches, each \$0.50 per doz. 5.00
No. 8 Benzine Brush, size 3 x 8½ inches..... each \$0.75 per doz. 7.50	

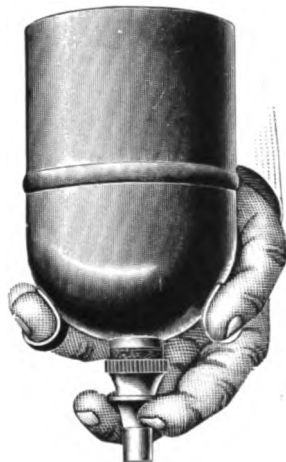

Quart Size Steel-Clad Can in Use

SAFETY BENZINE CANS

These cans have successfully passed all tests of the insurance companies, and are approved by Boards of Fire Underwriters in the United States and Canada.

STEEL CLAD

Pint Can, coppered.....	\$0.90
Quart Can, coppered.....	1.20
Extra Patent Stoppers, each.....	.40



Success Benzine Cans

BRASS

Half Pint.....	\$0.50	Two Quart.....	\$1.50
Pint.....	.60	Gallon.....	2.00
Quart.....	.75	Gallon, with handle.....	2.50
Extra Patent Stoppers, each.....	\$0.40		

TAPE FOR PRESSES AND FOLDING MACHINES

Sold in Rolls containing 36 yards

¾-Inch, per roll.....	\$0.75	1 -inch, per roll.....	\$1.50
½-Inch, " ".....	.75	1 ½-Inch, " ".....	1.60
¾-Inch, " ".....	1.00	1 ¾-Inch, " ".....	1.75
¾-Inch, " ".....	1.25	1 ½-Inch, " ".....	2.00
¾-Inch, " ".....	1.40	2 -inch, " ".....	2.50



Tape

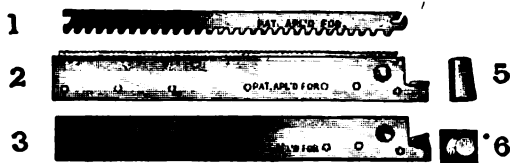

Damon Perforating and Scoring Machine

- 1 Scoring Blade
- 2 Machine with Perforating Blade Raised
- 3 Machine with Blade Depressed
- 4
- 5
- 6

DAMON PERFORATING AND SCORING MACHINE

Can be locked up in form with type and blades do the work neatly and accurately at the time it is printed without inking the perforations or creasing line and without touching the rollers.

No. 1 Machine 5 inches	Blade 4 ½ inches.....	\$3.00
No. 2 " 7 " "	" 6 ½ " "	4.00
No. 3A " 8 " "	" 7 ½ " "	5.00
No. 3 " 10 " "	" 9 ½ " "	5.00
No. 4 " 12 " "	" 11 ½ " "	6.00

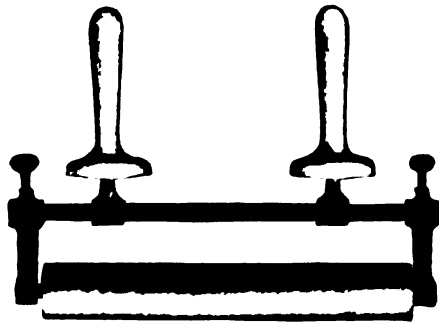

HAND ROLLERS

	Handles	Frame and Stock	Complete Roller Cast	Extra Stock
6-Inch	1.....	\$1.25	\$1.85	\$0.40
8-Inch	1.....	1.50	2.30	.45
10-Inch	1.....	1.75	2.75	.50
12-Inch	1.....	2.00	3.20	.60
14-Inch	2.....	2.25	3.65	.70
16-Inch	2.....	2.50	4.10	.75
18-Inch	2.....	2.75	4.55	.80
20-Inch	2.....	3.00	5.00	.85
22-Inch	2.....	3.25	5.45	1.00



IDEAL OVERLAY KNIFE

Made of the finest tempered steel and will hold a very keen edge. The handle is of wood and may be cut away as the blade is ground down. Price\$0.50

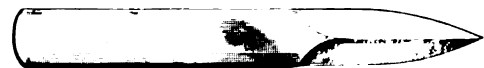

PRESSMAN'S STEEL KNIFE

Finely tempered and polished Ground sharp.

Knife.....\$0.50
Leather Case......10

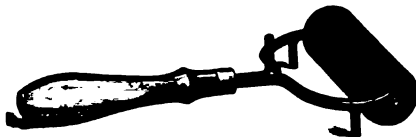

BRAYER ROLLERS

	Frame and Core	Roller Complete
6-Inch.....	\$0.90	\$1.20
8-Inch.....	1.00	1.40

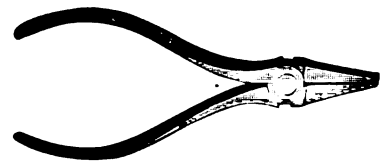

PLIERS

Flat or Round Nosed.....\$0.50

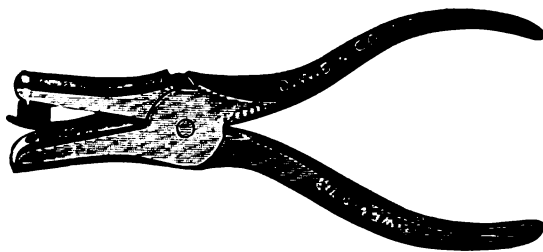

CARD PUNCHES

Made with steel punch and die

Cut shows one-half size.....\$1.25

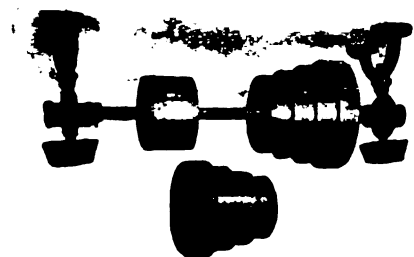

OVERHEAD FIXTURES

Countershaft, hangers and cone pulleys. When ordering give exact diameter of main shaft and number of revolutions per minute.

EIGHTH OR QUARTO MEDIUM

3 speeds, solid cone pulleys.....\$15.00
3 speeds, split cone pulleys..... 17.25
4 speeds, solid cone pulleys..... 18.00
4 speeds, split cone pulleys..... 21.00

HALF MEDIUM OR 14 1/2 x 22

4 speeds, split cone pulleys.....\$24.00



RECASTING ROLLERS

Rollers of all sizes recast from best quality composition at lowest prevailing prices. When ordering state whether summer or winter composition is desired. We can also supply roller composition in quantities to suit.

THE H. C. HANSEN TYPE FOUNDRY



THE CHANDLER & PRICE FOUNTAIN

Like the press, the Chandler & Price Fountain is very simple and effective. It is quickly cleaned; quickly adjusted to proper flow at any rate needed; easily removed from the press and replaced by extra fountain for colors, if desired. Ink blade is of finest steel and its adjustments insure positive flow.

Price..... \$20.00

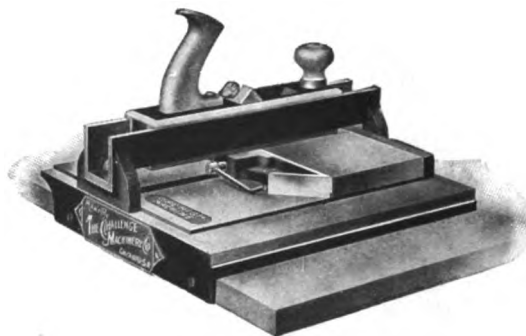

HOERNER'S COMBINATION SHOOTBOARD AND TYPE HIGH MACHINE

Three Machines in one—Shootboard, Type-High Machine and Miterer. A Boon to Printers. A convenience for every working day of the year. Quick, easy and true work. The carriage or guide frame being movable from side while operating, blocks of the full width of the bed can be shaved at one locking.

Complete, with two planes (1 file plane, 1 knife plane) \$35.00
 Extra Files..... .75
 Extra Knives..... .75

THE BUCKEYE FOUNTAIN

Easily attached and instantly interchangeable to any press—is perfect in both construction and action. The roller is easily removed for cleaning; ink supply regulated by a "twist of the wrist."

Price..... \$10.00

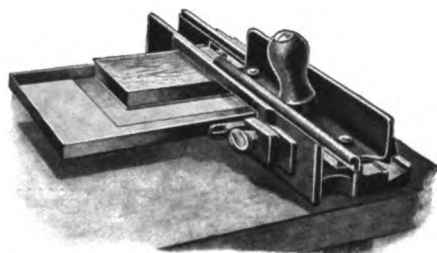
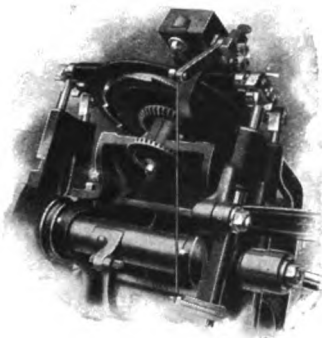

THE PILOT PRESS

The Pilot Press may be turned to excellent use in any printing office for small lots of cards, programs, invitations, hotel menus, etc. Very quickly made ready, strong, reliable and capable of good work. Inside chase measurement, 6½ x 10 inches.

Price..... \$33.00

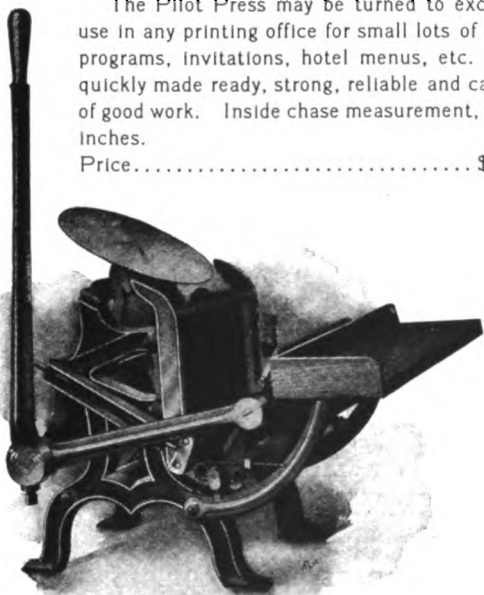

CHALLENGE TYPE-HIGH MACHINE

Will reduce cuts to type-high, and make them true and even when they have become warped from any cause. Passing all cuts, or plates mounted on wood through this machine before the form is sent to press saves one-half the time usually spent in make-ready.

Challenge Type-High Machine, with galley 8x12 inches \$15.00
 Extra Files for Challenge Type-High Machine..... .75

THE OFFICIAL PRESS

The frame and bed are in one casting, made from the best grade of iron, and so designed that the bed is centrally supported by the frame. The bed and platen are so reinforced by cross braces that it is impossible to spring them under the heaviest impression.

No. 2 4 x 6 inches... \$16.00
 No. 3 5 x 7½ inches... 25.00
 No. 4 6 x 9 inches... 35.00
 No. 6 8½ x 12½ inches... 60.00

Nos. 9 and 12

For printing large sheets. In this style platen is stationery, the bed being brought down to meet it.

No. 9 6 x 9 inches... \$45.00
 No. 12 8½ x 12½ inches... 80.00



THE H. C. HANSEN TYPE FOUNDRY

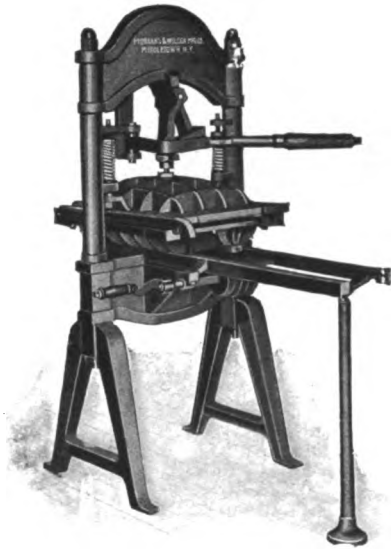

HAND PRESSES

These presses are of new design, with the latest improvements in construction and are made with the best of workmanship and material. They are heavily built, in good proportion and with the material correctly distributed according to the strains. They are easily and quickly operated and are particularly adapted to the use of printers and photo-engravers in proving cuts, giving solid impression.

No. 1	Bed 17 x 21,	Platen 14½ x 18½	Inches.....	Price \$150.00
No. 2	" 20 x 25,	" 17 x 22	"	" 175.00
No. 3	" 24 x 29,	" 20 x 25	"	" 200.00
No. 4	" 26 x 34,	" 22 x 30	"	" 225.00
No. 5	" 29 x 42,	" 25 x 38	"	" 250.00
No. 6	" 32 x 47,	" 28 x 43	"	" 275.00

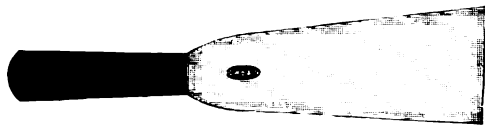

INK KNIVES, WIDE BLADE

6-Inch blade.....	\$0.60	8-Inch blade.....	\$1.00
10-Inch blade.....	\$1.60		



PALLET INK KNIVES

4-Inch blade.....	\$0.35	8-Inch blade.....	\$0.70
6 " "50	10 " "	1.00

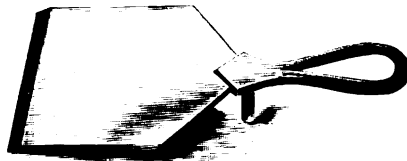

INK SLICE, STEEL BLADE

Handles cannot get loose..... \$0.75



CHALLENGE INK SPADE

Nickel plated..... \$0.60

TYMPAN GAUGE SQUARE

The invention of a practical printer for instantly securing straight margins on all jobs on platen presses. Especially useful in securing accurate register on forms printed in two or more colors. Will save its cost every day where time is worth anything. Made of transparent material ruled in pica-spaced squares. Price..... \$0.25

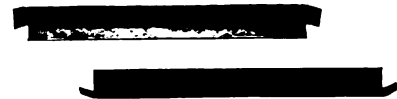
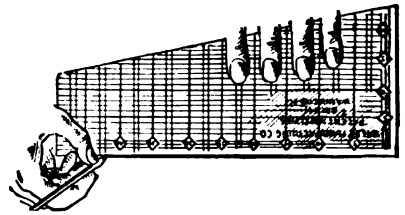

STEEL ROLLER SUPPORTERS

For 7 x 11 chase	pair \$0.40	For 11 x 17 chase	pair \$0.60
" 8 x 12 "	" .45	" 12 x 18 "	" .75
" 9 x 13 "	" .50	" 13 x 19 "	" .75
" 10 x 15 "	" .50	" 14 x 20 "	" .90
		For 14½ x 22 chase	pair \$0.90



BRASS LABEL HOLDERS

Price per hundred, complete, size 1 x 5½ inches, with cards and tacks..... \$2.75

THE H. C. HANSEN TYPE FOUNDRY



Self-Feeding, Self-Inking Proof Press

SELF-FEEDING, SELF-INKING WEB PROOF PRESSES

10-in. Bed, Single Web, to print matter 26 in. long,	\$330.00
12-in. " " " " " " " " " " " " " " " "	355.00
12-in. " Double " " " " " " " " " " " " " "	380.00
18-in. " Single " " " " " " " " " " " " " "	415.00
18-in. " Double " " " " " " " " " " " " " "	440.00
22½-in. " Single " " " " " " " " " " " " " "	525.00
22½-in. " Double " " " " " " " " " " " " " "	550.00

EXTRA HEAVY

25-in. Bed, Single Web, to print matter 36 in. long	\$650.00
28-in. " " " " " " " " " " " " " " " "	700.00

Prices for Direct Motor Equipment furnished on application.



Herald Self-Inking Proof Press

PATENT HERALD SELF-INKING PROOF PRESS

	Without Feed-board	With Feed-board
10-in. Bed, prints matter 26 in. long,	\$275.00	\$330.00
12-in. " " " " " " " " " " " " " " " "	300.00	355.00
18-in. " " " " " " " " " " " " " " " "	340.00	415.00
22½-in. " " " " " " " " " " " " " " " "	400.00	525.00

EXTRA HEAVY

25-in. Bed, prints matter 36 in. long,	\$525.00	\$650.00
28-in. " " " " " " " " " " " " " " " "	575.00	700.00

All presses furnished complete with cast rollers



Chandler & Price Proof Press

ROLLER PROOF PRESSES

CHANDLER & PRICE

No. 1. 10 x 31 inches, with Frame.....	\$30.00
" " " " without "	22.50
No. 2. 16 x 31 " " with "	40.00
" " " " without "	30.00

CHALLENGE

No. 0. 9 x 27 inches, with Iron Stand.....	\$ 25.00
No. 1. 10½ x 32 " " " " " "	30.00
No. 2. 16½ x 35 " " " " " "	40.00
No. 3. 20 x 38 " " " " " "	60.00
No. 4. 24 x 42 " " " " " "	75.00
No. 5. 27 x 54 " " " " " "	125.00
No. 6. 9 x 40 " " " " " "	30.00

GOLDING

No. 1. Bed 5 x 27 inches, with stand.....	\$22.00
" " " " without stand.....	15.00
No. 2. " 8½ x 27 " " with "	27.00
" " " " without "	20.00
No. 3. " 15 x 27 " " with "	38.00
" " " " without "	30.00

CHALLENGE TIE-UP SLUGS

Made of the best grade metal and are grooved on one side so that they can be placed around type pages, when being locked up, without removing string. They are standard height and point system in thickness.

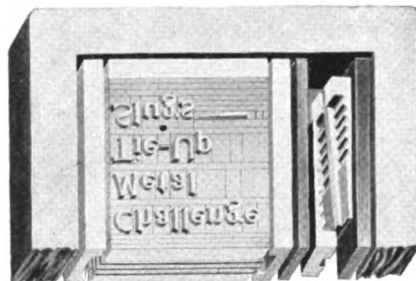

Full Length, 18 inches long.....	per lb. \$0.18
Cut to measure, 7 ems pica and over.....	per lb. .25
Cut to measure, 4 to 6½ ems pica.....	per lb. .35
Labor-Saving Fonts, 5, 10 or 25 lbs.....	per lb. .25



THE WHITLOCK CYLINDER PRESS

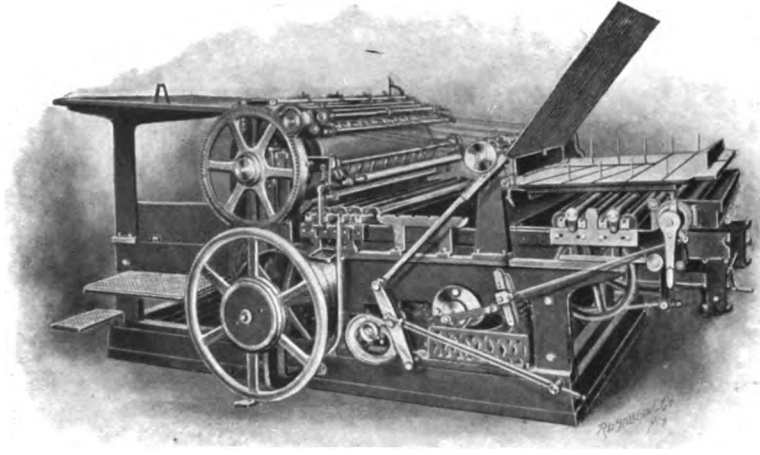

Whitlock Two-revolution, Four-roller Press

WHITLOCK TWO-REVOLUTION FOUR-ROLLER PRESS Front Fly Delivery

The swiftest, smoothest running, simplest, most durable and most efficient of the two-revolution presses.

Built in the following sizes:

Bed, inches	Form Covered	Sheet
46 x 65	41 x 61	43 x 63
43 x 56	38 x 52	40 x 54
41 x 52	36 x 48	38 x 50
35 x 47	30 x 43	32 x 45
29 x 42	24 x 38	26 x 40

Specially designed to do not only the finest half-tone printing in black and three-color, but also to be equally efficient for the general work of the modern printing office, having special regard for the production of the finest quality in the largest quantity, at the least possible cost.

All Whitlock presses are built with extra heavy double-arched girder directly under the impression, and the heavy girder at each end of the machines, impart strength and solidity.

The new Crank Bed Movement is a modification of the bed driving mechanism employed in almost all stop cylinder and lithograph presses—the simplicity, durability and register exactness of these machines being retained, and modern speed being imparted by use of speed gears. The Box Type Bed has a bottom surface and not merely the usual cross ribbing. This fully doubles the strength of the type bed; it is also scraped absolutely true. The Cylinder is larger in diameter than is commonly used, thereby lessening considerably the wear on type and plates. The Fountain is adjustable and may be tipped to any angle, forcing the ink down on the fountain roller, thereby preventing color from working light. It also saves ink waste. All Ink Rollers are interchangeable, being of same diameter. Old form rollers can be used as angle rollers, thus saving roller expense. The Hinged Roller Frame with Roller lifting device is so finely balanced that an easy swing of a lever lifts the top riding and vibrating rollers from off the form rollers, the form rollers being lifted away from the form at the same time. Trip and Back-up Motion both are on all Whitlock presses. The trip cannot be broken through improper timing. The back-up operates by friction and acts instantly without any damage to the press.

Either Front Fly Delivery (as shown in illustration) or the carrier delivery (printed side up) is supplied.

Prices and further information about other meritorious features of the Whitlock press, which space does not permit giving in detail, may be obtained on application.

WHITLOCK TWO-REVOLUTION TWO-ROLLER PONY PRESS

Carrier Delivery (Printed side up)
(Also built with Front Fly Delivery)

The swiftest, smoothest running, simplest, most durable and convenient of all pony presses. Has the meritorious features of the larger Whitlock presses.

Made in two sizes.

Bed....27 x 31	Bed....27 x 40
Type....22 x 27	Type...22½ x 36
Sheet...24 x 29	Sheet...25 x 38

Prices and further particulars may be obtained on application.

When in the market for any kind of cylinder press, new or second hand, be sure and write us.

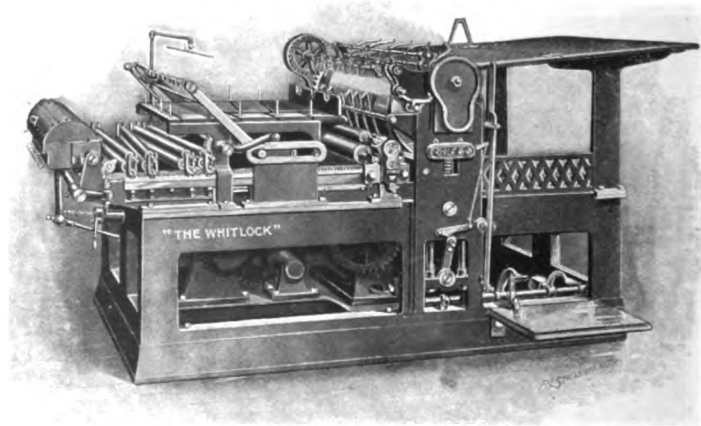

Whitlock Two-roller, Two-revolution Pony Press

THE H. C. HANSEN TYPE FOUNDRY

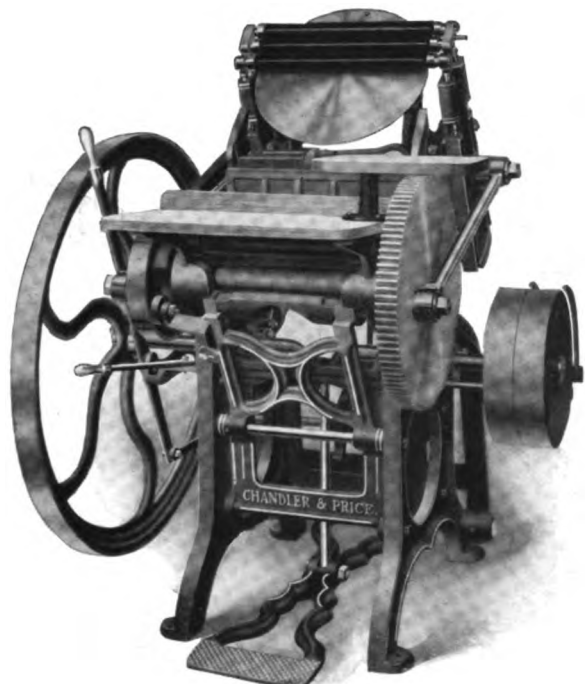

Chandler & Price Gordon Press

THE CHANDLER & PRICE PRESS

Stock always on hand

The long life of the Chandler & Price Gordon Press is insured by its extra heavy weight and the materials of which it is made. Also by the great care which enters into its construction, every part of the press being made by machinery specially designed for the purpose which insures perfect uniformity and accuracy. The frame is constructed of the best grade of iron. The side arms and shaft are of forged steel. The throw-off is instantaneous, positive and easily operated, without springs, clamps or catches. The depressible grippers cannot get beneath the rollers. The chase clamp is positive and instantaneous. The distribution is unsurpassed. The horizontal platen with long rest insures speed and ease in feeding. Every press is given an expert's severe test before leaving the factory.

Eighth Medium,	7 x 11	inside chase.....	\$150.00
"	7 x 12	" "	165.00
Quarto	10 x 15	" "	250.00
Large Quarto	12 x 18	" "	300.00
Half Medium	14 x 20	" "	400.00
"	14½ x 22	" "	450.00

EXTRAS FOR EITHER SIZE PRESS

Steam Fixtures.....	\$15.00
Buckeye or Short Fountain.....	10.00
Chandler & Price Fountain.....	20.00

Write for Net Prices

The New Vibrating Riding Roller is as easily attached as an ordinary form roller. It prevents streaking, renders unnecessary double rolling, saves ink and time. Complete, any size, \$10.00

THE PEERLESS PRESS

This press is simple, strong and readily understood and operated. It is so constructed that every motion is positive and there being no adjustments, it is simply impossible for even the most inexperienced person to get it out of order. It is made with tools specially constructed for the purpose and all parts are interchangeable. The strain-bearing parts are steel and are made very heavy which insures great strength. The impression is given by a toggle, applied behind the platen-yoke. This motion is very simple and powerful. The chase is instantly and securely fastened to the bed by an automatic chase-hook. The throw-off is an eccentric, operated by a lever which locks itself in either position.

8 x 12 Peerless Press.....	\$225.00	11 x 17 Peerless Press.....	\$350.00
9 x 13 " "	250.00	14 x 20 " "	450.00
10 x 15 " "	300.00	14½ x 22 " "	500.00

EXTRAS FOR EITHER OF THE ABOVE PRESSES

Long Fountain.....	\$25.00	Pony Fountain.....	\$10.00
Steam Fixtures.....	\$15.00		

Write for Net Prices

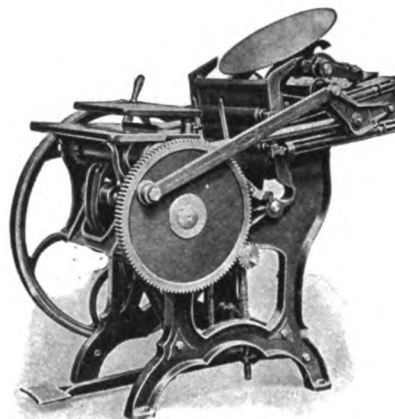

The Peerless Press

THE PEARL PRESS

The Pearl is the speediest, easiest running press of its size ever invented. The small number of fly-wheel revolutions to the impression makes it particularly desirable in offices which do not use a mechanical drive. On all sizes the bed is perpendicular, heavily ribbed in both directions at the back, and of convex construction, providing extra metal at the point of greatest strain to prevent springing. A powerful chase clamp holds the form rigidly to the bed. The platen lies in a position that facilitates rapid and accurate feeding, and, because of the long feed-dwell (one-half of each press movement), may be operated at a very high speed.

Pearl No. 1. 5 x 8 inches.....	\$ 70.00
Pearl No. 3. 7 x 11 inches.....	110.00
Improved Pearl No. 8. 5 x 8 inches.....	95.00
Improved Pearl No. 11. 7 x 11 inches.....	135.00
Improved Pearl No. 14. 9 x 14 inches.....	200.00

Nos. 1 and 3 are without throw-off. Nos. 8, 11 and 14 have throw-off and full length fountain.
 Steam Fixtures, No. 1 \$8.00, No. 3 \$9.00, No. 8 \$10.00, No. 11 \$12.00, No. 14 \$14.00.

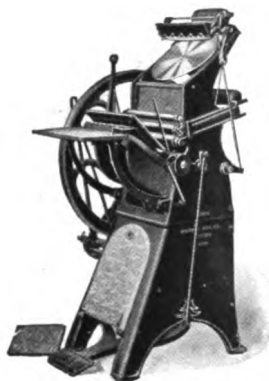

The Improved Pearl Press

THE H. C. HANSEN TYPE FOUNDRY

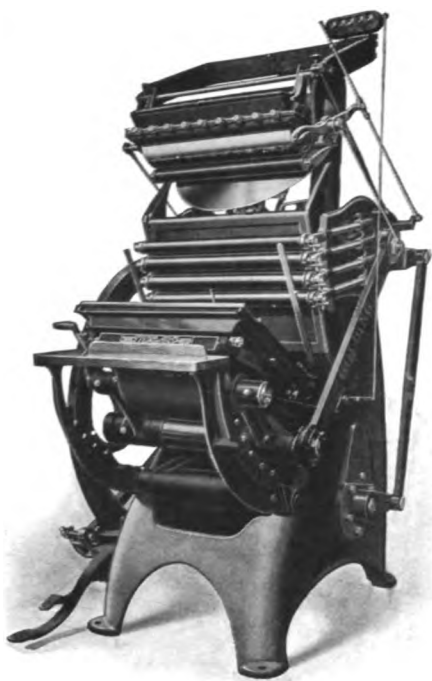

Golding Art Jobber

THE GOLDING JOBBER

The Golding Jobber in the regular series is made for use on ordinary classes of work where it is important that the maximum output be realized and at the smallest percentage of labor. The Golding Art Jobber is made to supply the demand for a machine capable of turning out the highest grade of work.

No. and Name	Size of Chase inside	No. of Form Rollers	Without Fountain and Fixtures	Regular Fountain and Fixtures	With Art Fountain and Fixtures
No. 6. Eighth Medium	8 x 12	3	\$200.00	\$250.00
No. 7. Quarto Medium	10 x 15	3	275.00	335.00	\$370.00
No. 8. Half Medium	12 x 18	3	350.00	420.00
No. 9. Half Super Royal	15 x 21	3	450.00	525.00
No. 18. Art Series	12 x 18	4	470.00	500.00
No. 21. Art Series	15 x 21	4	490.00	560.00	600.00

(1) These prices are with machine rollers complete, extra set of roller cores, extra set of roller wheels, two chases, wrench, treadle and brake. Unless otherwise ordered, steam fixtures are furnished with the Jobbers No. 9, 18 and 21 instead of treadle.

(2) These prices include Automatic Fountain, Duplex Distributer, Steam Fixtures with Automatic Belt Shipper and Quick-

stop brake, complete set of composition rollers with extra set of cores, extra set of roller wheels, two chases and wrench. Complete press does not include counter and its attachments, as these are extra.

In setting up platen presses, two or three feet of space between each machine should be allowed. The fly wheels on all sizes turn from the feeder.

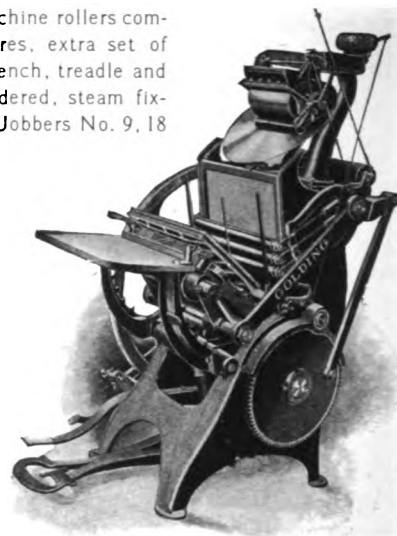

Golding Jobber

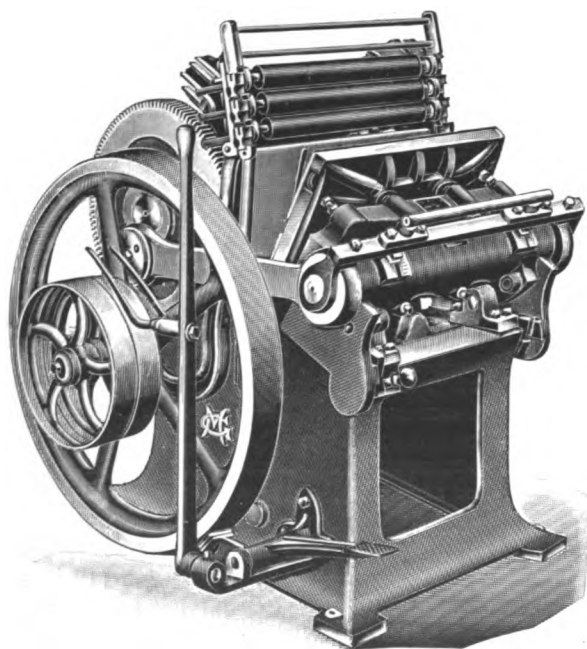

Gally Improved Universal Style I

GALLY IMPROVED UNIVERSAL

This is the regular press, adapted for general letterpress printing. An improved gear wheel is now put on all Style One Universals, except the 10 x 15, with a section of steel cast into the cam-way at the place where the friction roller wears the hardest.

10 x 15	Shipping weight, 1,900 lbs.....	\$255.00
13 x 19	Shipping weight, 2,700 lbs.....	360.00
14 x 22	Shipping weight, 2,850 lbs.....	410.00
17 x 25	Shipping weight, 3,300 lbs.....	550.00

Above prices are for Style 1. Prices of other styles will be furnished on request. Prices subject to change.

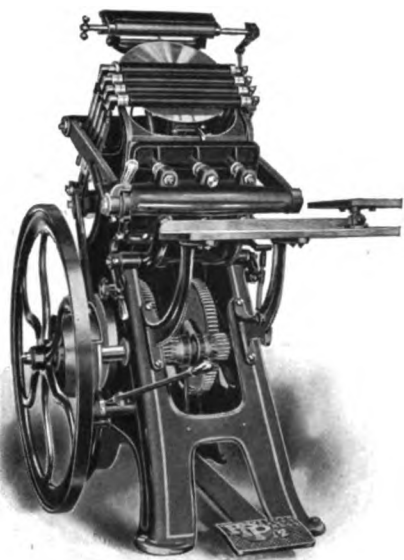

No. 2 Improved Perfected Prouty Press

IMPROVED PERFECTED PROUTY PRESS

A rigid, speedy, durable press with two main gear wheels, rigid and powerful impression, four rollers, platen adjuster, improved chase-latch, new throw-off, special improved ink fountain, double end roller trucks. It is easily made ready. Built in five sizes. Full particulars on application.

No. 1.	7 x 11	Inches	inside chase	\$215.00
No. 2.	9 x 13	"	"	284.00
No. 3.	10 x 15	"	"	338.00
No. 4.	12 x 18	"	"	417.00
No. 5.	{ 12 x 20 } { 13 x 21 }	Inches	inside chase	450.00

Prices given include full length fountain and side steam fixtures.

PROUTY WOOD PRINTING PRESS

No.	Chase	Boards	Price
No. 1.	7 x 11	10 x 14	\$220.00
No. 2.	9 x 13	11 x 18	315.00
No. 3.	10 x 15	12 x 22	375.00
No. 4.	12 x 18	15 x 24	465.00
No. 5.	{ 12 x 20 } { 13 x 21 }	16 x 26	500.00
Spec. 5.	{ 12 x 20 } { 13 x 21 }	16 x 34	555.00

Write for Net Prices



Special No. 5 Prouty Wood Printing Press. 34 inch

THE MIDGET STAPLE BINDER



Midget Staple Binder

It is strongly built, cannot clog and needs no adjusting. It holds 100 staples at a charge and will bind a little over 1/4 inch any kind of paper. Very useful in offices or can be used in making up samples. Finished in nickel. Price, in neat box.....\$3.00

IMPROVED LIGHTNING BINDER No. 2

For Printers and Binders this is a good low-priced machine for binding pamphlets or stitching calendars. Holds 200 staples at a charge. Staples can be inserted six inches from margin. Only one adjustment—by means of a hand screw which elevates or depresses the clincher. Capacity 2 sheets up to 125 sheets. Six sizes of staples may be used, from 3-16 in. to 1-2 in.

Price.....\$25.00

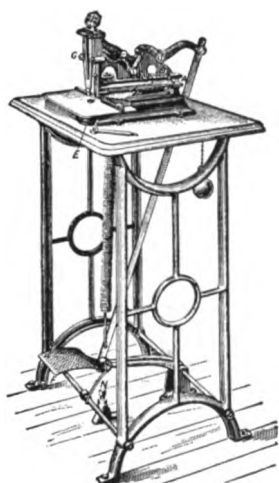

Imp. Lightning Binder No. 2

ACME BINDER No. 6

The Acme No. 6 binds to one-quarter inch, all kinds of paper. It has an automatic clinching device. It is equipped with anti-clogging devices and both flat and saddle-back tables. No adjustment required. The machine uses 250 staples at each charge, numbered as follows: No. 21, fine wire, 1/4-inch; No. 22, fine wire 5/16-inch; No. 23, coarse wire, 1/4-inch; No. 24, coarse wire, 5/16-inch.

Price.....\$35.00

Write for further particulars and net prices of any of the above machines.



Acme Binder No. 6

THE H. C. HANSEN TYPE FOUNDRY

COLT'S ARMORY PLATEN PRESSES

The Quarto Medium is built in the Style One and Style Two constructions. The Style One has two form rollers and Style Two has three form rollers.

The Half Medium and the Half Super Royal are now built in the Style Two-A, Style Five-A and Style Six-A constructions.

The Quarto Medium Style One is particularly a high-speed press. It can be operated as rapidly as the "disc" type of machine and has more effective ink distribution.

The Quarto Medium Style Two is better adapted, through its greater distribution, for halftone and color printing.

The Half Medium and Half Super Royal in the Style Two-A construction are equal to the average requirements of high-class printers. They are high-speed presses.

The Half Medium and Half Super Royal in the Style Five-A construction are much stronger machines than the Style Two. They are adapted for all the Style Two is capable of doing and also for a much heavier range of work, especially in the way of half-tone, chromotype and tint printing. They are high-speed presses.

The Half Medium and the Half Super Royal in the Style Six-A construction are modifications of the Style Five, adapting them for all that can be done on the Styles Two and Five and also for certain classes of embossing, book-cover stamping and the like, hot or cold.



Style Two-A Colt's Armory Press

QUARTO MEDIUM, STYLE TWO

Size, 10 x 15 inches inside of chase. Carrying three form roller, two distributor and one vibrator stocks, each to be cast 2 inches in diameter. Will operate safely and smoothly up to 2200 impressions an hour. Space through which press will pass when assembled, 33½ inches; when wholly dismembered, 19½ inches.

Price of Press, complete with ink fountain, driving pulleys, belt shifter and brake.....\$350.00

The following parts are included: 6 form roller stocks; 4 distributor stocks; 2 vibrator stocks; 4 distributor stock boxes; 4 adjusting clamps; 6 form roller wheels, 1 ¼ inches diameter; 6 form roller wheels, 1 ½ inches diameter; 5 chases; 2 feed tables; 2 feed table floor standards; 3 frisket fingers; 1 treadle; 3 wrenches.

HALF MEDIUM, STYLE TWO-A

Size, 13 x 19 inches inside of chase. Carrying three form roller, two distributor and one vibrator stocks, each to be cast 2 inches in diameter. Will operate safely and smoothly up to 1800 impressions an hour. Space through which press will pass when assembled, 41 inches, when wholly dismembered, 29½ inches.

Price of Press, complete with ink fountain, driving pulleys, belt shifter and brake.....\$500.00

The following parts are included: 6 form roller stocks; 4 distributor stocks; 2 vibrator stocks; 1 changer; 4 distributor stock boxes; 4 adjusting clamps; 6 form roller wheels, 1 ¼ inches diameter; 6 form roller wheels, 1 ½ inches diameter; 5 chases; 2 feed tables; 2 feed table floor standards; 3 frisket fingers; 3 wrenches.

HALF SUPER ROYAL, STYLE TWO-A

Size, 14 x 22 inches inside of chase. Carrying three form roller, two distributor and one vibrator stocks, each to be cast 2 inches in diameter. Will operate safely and smoothly up to 1700 impressions an hour. Space through which press will pass when assembled, 43 inches, when wholly dismembered, 32½ inches.

Price of Press, complete with ink fountain, driving pulleys, belt shifter and brake.....\$575.00

The following parts are included: 6 form roller stocks; 4 distributor stocks; 2 vibrator stocks; 1 changer; 4 distributor stock boxes; 4 adjusting clamps; 6 form roller wheels, 1 ¼ inches diameter; 6 form roller wheels, 1 ½ inches diameter; 5 chases; 2 feed tables; 2 feed table floor standards; 3 frisket fingers; 3 wrenches.

When double inking device is furnished with any of the above described presses, the price thereof will be \$15.00 net.

Prices and particulars regarding Style One, Style Five-A and Style Six-A will be given on application.

Write for Hansen's list of Rebuilt Presses.

Write for Net Prices

THE H. C. HANSEN TYPE FOUNDRY

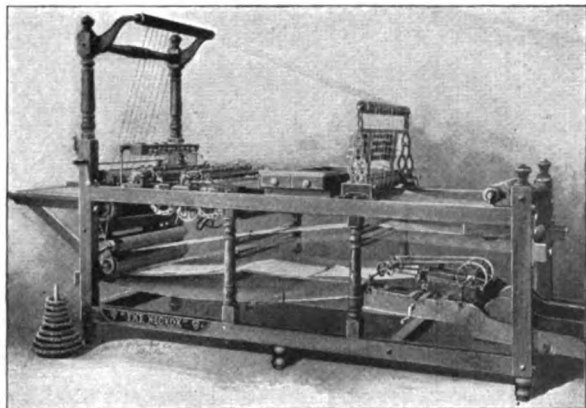

Style 5 O-A "Duplex" Ruling Machine, having two O-A Automatic Striker Beams with 1 1/2 Lay-boy

HICKOK RULING MACHINE

The Hickok O-A styles of Ruling Machines are known throughout the entire civilized world as being the best and most complete Ruling Machines.

The O-A Strikers of the Ruling machine are the styles preferred by 90 per cent of the trade throughout the world, and can be found in almost every ruling shop in the United States and Europe.

Built in sizes and styles for every class of work.

Full particulars and prices on application. In writing for information give full description of class of work you propose doing.

THE MENTGES FOLDER

The Mentges Folder contains no frail or delicate parts. The frame is built for strength, solidity and compactness, and is made of highest grade cast-iron, ribbed throughout to give the greatest strength, lightness and rigidity. All castings are of the same high quality, reinforced with ribs, thus enabling them to withstand the utmost strain without fear of breakage.

It is simple in construction and easy to operate, it is unsurpassed in durability, speed and accuracy of its work.

The new model is equipped with especially designed steel rollers—not the old style wood rollers, cloth covered. These steel rollers cannot warp, swell, stick, or give trouble in any way. They are turned true in a lathe and then milled, thus adding a valuable and durable improvement.

The folding knives in this machine are of highly polished steel, with saw teeth and will last for years.

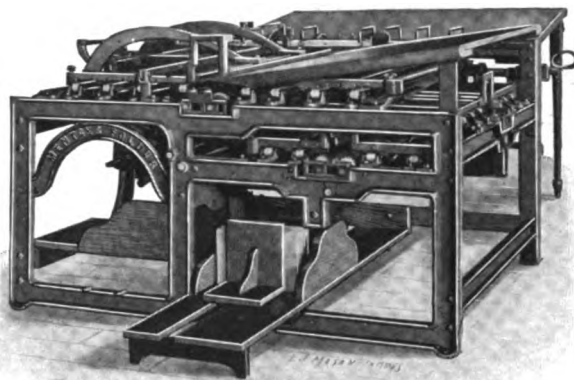

Style 2 Mentges Folder

Mentges Folder, Style No. 2. 4, 6, 8, 10 or 12 pages, with 8- and 10-page paster and trimmer.....\$225.00
 6-page paster, extra.....\$15.00 12-page paster, extra.....\$15.00
 Particulars and prices of other styles and sizes on application.

BROWN CATALOG AND BOOK FOLDERS

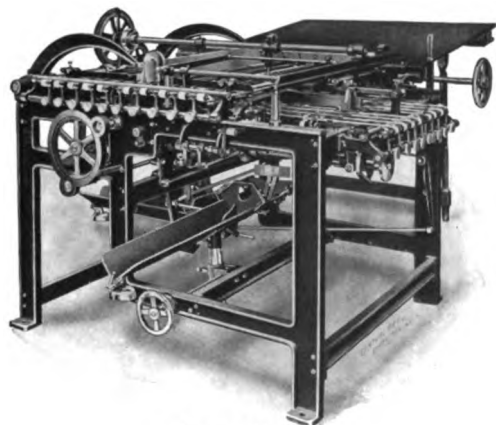

Brown Folder No. 131

This is another entirely new design, taking the place of the old No. 133, which is now known as No. 133 1/2.

It is larger, being 33x45 inches in size, and folding down to 11x14 inches. It is a Two, Three and Four-fold Machine, and has a very wide range of work, folding both Regular and Oblong work in various sizes.

It folds 8, 12, 16, 24 and 32 pages.

It has Automatic Revolving Sheet Retarder, Automatic Gripper Side Registers, both Right and Left Hand at the first fold, Push Side Registers at third and fourth folds, Adjustable Tape Tighteners, Micrometer Adjustments on end stops, 16 and 32 Page Head Perforators and Adjustable Packers.

The Head Perforators are thrown in and out of use from the outside of machine. This is a great time saver and convenience.

Price.....\$1200.00 8-page paster.....\$50.00
 Extra Set Rolls, parallel to third set for 24's and 32's in gangs, \$150.00

Brown Catalog Folder No. 131. This is a Two and Three-Fold Machine, 25x38 in size, and folding down to 12x16. It folds 8, 12 and 16 pages. Has Automatic Gripper Side Register at first fold, 16 Page Head Perforators, Automatic Sheet Retarder and Adjustable Tape Tighteners. Price, \$600.00. 8-page paster, \$50.00. Fourth set of folding rolls, \$150.00 32-page Head Perforator, \$35.00.

Prices and specifications of various other styles of Folding Machines sent on request.

THE H. C. HANSEN TYPE FOUNDRY

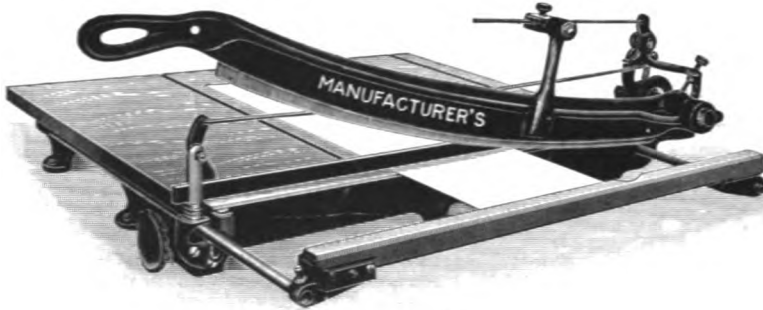

MANUFACTURER'S CUTTER

A strong machine having a 24-inch blade, adapted to any reasonable work for which such a cutter may be used. An essential feature is the automatic grip or binder which securely holds the work in position before the descending blade begins to cut and throughout its movement.

Price.....\$25.00



STUDIO CUTTER

This cutter has a 10-inch blade and is suited for light work.

Price.....\$3.00

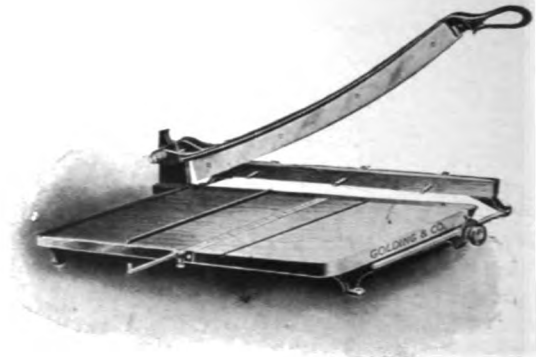

BOSTON CARD CUTTER

Made in three sizes. The frame is made of iron, all parts being accurately fitted. The table is made of well-seasoned hardwood. The knives are made of best tempered cast steel, and they are also made in curved form to have a drawing cut so that no clamp of any kind is necessary to hold the stock.

- No. 8. 8½-inch blade.....\$ 8.00
- No. 12. 12¼-inch blade..... 12.00
- No. 24. 24¼-inch blade..... 21.00

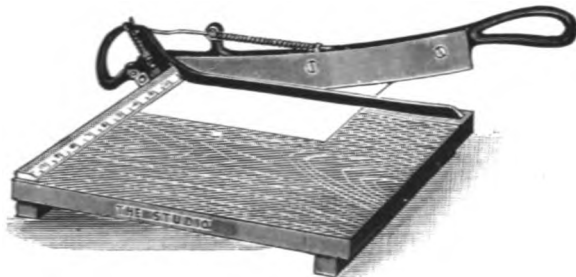

STUDIO CUTTER AND BINDER

Some people prefer a binder attached to the trimmer. We can furnish the trimmers and binders as follows:

- Diamond Trimmer and Binder.....\$1.75
- Dandy Trimmer and Binder..... 2.75
- Studio Cutter and Binder..... 3.75

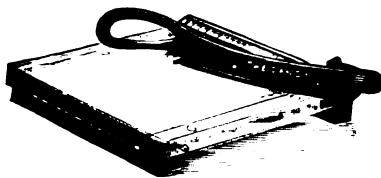

DANDY PHOTO TRIMMER

This trimmer has a blade 8 inches in length; the curved blade gives a good clean cut.

Price.....\$2.00

DIAMOND PHOTO TRIMMER

This is practically a smaller edition of the Dandy trimmer and it is made to meet the demand for a lower priced cutter. It has a blade 6 inches in length.

Price.....\$1.25

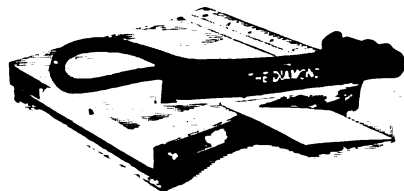

PREMIUM CARD CUTTER

A popular, general, all round cutter with 12-inch blade, meeting the requirements of a medium sized cutter. A distinct advantage is secured by a peculiar arrangement of the joint, by which a sheet of any length may be cut. Attention is called to the adjustable back gauge, which can be clearly seen in the illustration. It is a great improvement over the former gauge.

Price.....\$10.00

THE POPULAR CUTTER

This cutter has a 15-inch blade and a number of special features. The table is lined in ¼-inch squares. The lower knife is secured to a strip of wood separated from the table by a space more than sufficient to allow for a possible swelling of the table, thus making the position of the knife permanent.

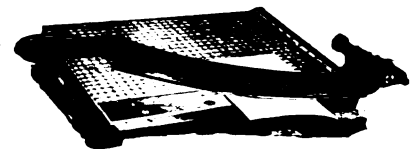

Price.....\$7.00

Every Printer should investigate Hansen's new invention for reproducing typewritten letters on job presses. The most practical yet devised

THE H. C. HANSEN TYPE FOUNDRY

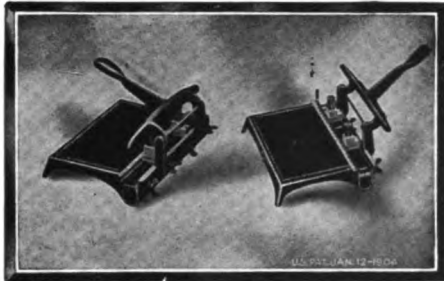

Unimatic Punch No. 2

UNIMATIC PUNCH No. 2

The most convenient and practical low price punch on the market. It is made with removable and adjustable punch heads, and will punch holes in any sheet, any distance apart up to 10½ inches. Maximum distance from center of hole to edge of sheet for special heads that can be used in this machine is ½ inch. The punch has adjustable side and back stops and a graduated scale for setting punch heads. The punch heads may be set any distance apart and locked firmly into position by thumb screws. The punches may be easily removed or changed. Nicely finished in Japan and Gilt with punch head and small parts nickel plated. Size 11 x 8½ inches.

No. 2 Unimatic Punch including any two single round hole dies of the following sizes: 1-8", 3-16", 1-4", 7-32", 5-16", 3-8", 13-32".....\$7.50

UNIMATIC PUNCH No. 3

The No. 3 Unimatic Punch is similar to the No. 2 in construction, but is larger, heavier and stronger. Also it is capable of punching holes any distance apart up to 14½ inches in any length of sheet. This Machine takes the same punch heads as the No. 2 and is also adaptable for punching holes ½ inch center of hole to edge of sheet. It is nicely finished in Japan and Gilt same as the No. 2.

No. 3 Unimatic Punch including any two single round hole dies of the following sizes: 1-8", 3-16", 1-4", 7-32", 5-16", 3-8", 13-32".....\$15.00

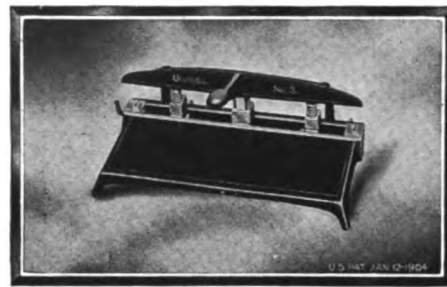

Unimatic Punch No. 3

UNIMATIC PUNCH HEADS

STYLE C. U.

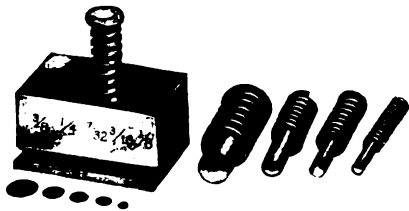

Style C. U.

Combination head, comprising five round hole punches as follows: 1-8", 3-16", 7-32", 1-4" and 3-8". Fitted with five punches, four of which may be removed, leaving desired size for punching.

Price each \$3.00

STYLE U

For punching single round holes, for post binders Shannon files, etc. Carried in stock in the following sizes: 1-8", 3-16", 7-32", 1-4", 5-16", 3-8" and 13-32"

Price each \$1.25



Style U

STYLE 13 U

Card Index Die, for punching slotted hole to fit card index.

Price each \$7.50

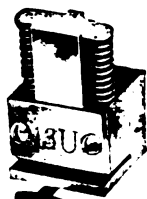

Style 13 U

STYLE 11 U

Card Index Die, for punching slotted hole to fit card index.

Price each \$7.50



Style 11 U

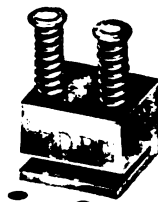

Style D. U.

STYLE D. U.

For punching double round holes 3-16" in diameter and 1-2" between centers, for S. & T. Prong price books, or 7-32" in diameter and 27-32" between centers for Reliable, Tengwall or Government files.

Price each \$2.00

MULTIPLEX PUNCHES

We also sell the Multiplex Punches made by the manufacturers of the Unimatic. They are similar to the Unimatic in construction but of greater capacity and accommodate a larger range of work. Write for descriptive circular.

Prices: No. 214, Hand Power, \$35.00. No. 216, Foot Power, \$50.00. No. 216, Foot Power, mounted on table, \$75.00



MONITOR WIRE STITCHERS

The Monitor Wire Stitchers embody the result of years of experience and costly experiment, covering simplicity and durability in all points. All working parts are made of the finest material obtainable and the workmanship is of the highest grade. All working parts are in plain view of operator. The wire is fed straight into machine forming a true and perfect staple which is absolutely necessary for all classes of stitching thicker than one-half inch. Furnished with every convenience to insure speed and accuracy of work.

Size 000	20th Century.	Capacity $\frac{3}{4}$ to 2 inches, weight 850 lbs.....	\$700.00
" 00	20th Century.	Capacity 2 sheets to 1 $\frac{1}{2}$ inches, weight 700 lbs.....	475.00
" 0	20th Century.	Capacity $\frac{1}{2}$ to 1 $\frac{1}{2}$ inches, weight 600 lbs.....	400.00
" 1	20th Century.	Capacity 2 sheets to $\frac{3}{4}$ inch, weight 480 lbs.....	300.00
" 1 $\frac{1}{2}$	20th Century.	Capacity 2 sheets to $\frac{3}{4}$ inch, weight 440 lbs.....	265.00
" 1 $\frac{3}{4}$	20th Century.	Capacity 2 sheets to $\frac{1}{2}$ inch, weight 400 lbs.....	235.00
" 2	Roll Feed.	Capacity 2 sheets to $\frac{3}{4}$ inch, weight 325 lbs.....	200.00
" 2 $\frac{1}{2}$	Roll Feed. Calendar.	Capacity 2 sheets to $\frac{1}{2}$ inch, weight 320 lbs.	175.00
" 4	Direct Feed. Foot Power.	Capacity 2 sheets to 1-5 inch, weight 270 lbs.....	100.00
Box Machine, power,		weight 285 lbs.....	160.00

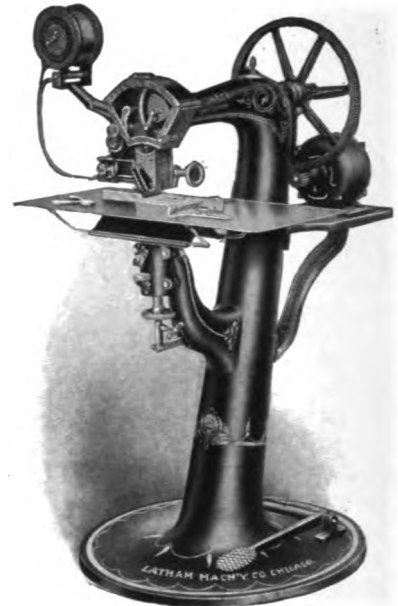

No. 1 Monitor Wire Stitcher with Motor Equipment

BOSTON WIRE STITCHER

The Boston Wire Stitcher is a strong, exceedingly simple machine, being self regulating in all parts, except setting the thickness of work. This operation of compressing the pad of paper (constituting the job) by means of a hand wheel, sets the feed, cutter, clinchers, table, and every part of the stitcher to absolute adjustment. The best quality of material is used in construction, all working parts being the finest quality of hardened steel. Each machine is subjected to rigid tests before leaving the factory.

No. 3.	Capacity 2 sheets to exceeding $\frac{3}{4}$ inch, weight 290 lbs.....	\$200.00
No. 4.	Capacity 2 sheets to $\frac{1}{2}$ inch, weight 335 lbs.....	250.00

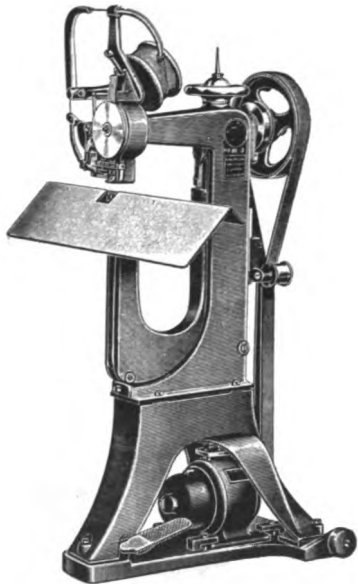

No. 3 Boston Wire Stitcher with Electric Equipment

BOSTON STAPLE BINDER

The Boston Staple Binder is designed to meet the requirements of offices not having work enough to warrant the expense of a wire stitcher. It is built on new lines and is the nearest approach to a stitcher yet devised. It is difficult to distinguish its stapling from the best wire stitching. The foot-power Boston Stapler is made in two styles. Style A has a pedestal and Style B must be screwed to a bench or table, the treadle attaching to the floor. The capacity of both styles is 3-16 of an inch, flat or saddle work.

Style A, Pedestal.....	\$35.00
Style B, Bench.....	25.00

Staples put up in boxes of 5000. Special discount for quantity orders.

Write for Hansen's List of Rebuilt Machinery

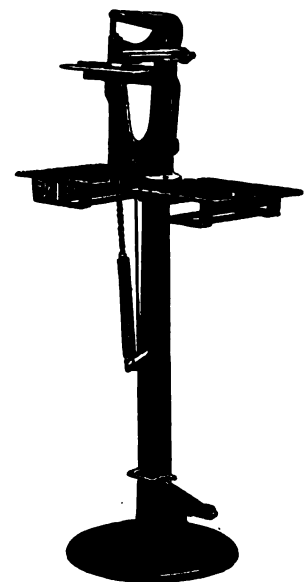

Boston Staple Binder. Style A

THE H. C. HANSEN TYPE FOUNDRY



HANSEN'S IMPROVED CURVING MACHINE



THE
SIMPLEST AND MOST PRACTICAL
CURVING MACHINE
ON THE MARKET
PRICE, \$15.00

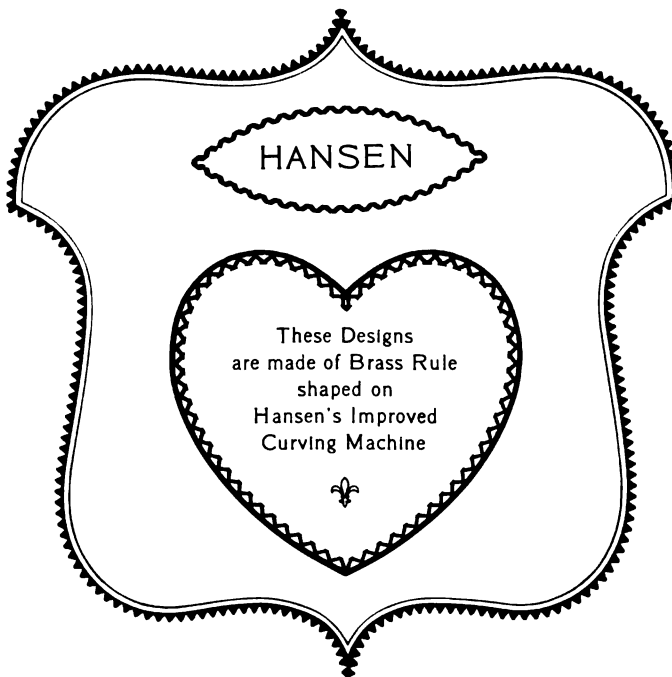

It will rapidly and accurately bend brass rules, leads or slugs into circles, ovals, or curves of almost any size; it will also straighten out curved or bent pieces of rule so that they may be used indefinitely.

The construction of the machine is simple, solid and powerful. The curving cylinder can be easily detached, and circles, ovals, etc., taken from it without injuring their completeness. The degree of curve desired is constantly at the will of the operator. Invaluable for bending steel cutting rule for box manufacturers.

HANSEN'S POWER IMPROVED PIN-HOLE PERFORATOR

The cut represents the new Pin-Hole Perforator, which for durability, strength and general utility stands second to none, having a number of advantages over all other machines.

It consists of two die wheels placed in such a position as to register perfectly, with no gearing to get out of order.

It has a nicely finished table with gauge on side which can be quickly and accurately set at any distance from the point of perforation.

It will perforate a sheet 26 inches wide and any desired length.

An excellent feature of this machine and one that will be appreciated, is that it does the work in one-fourth the time consumed by any other machine, and may be run by either hand or power.

A prominent printer says of Hansen's Perforator: "I could easily dispense with some of my other machines, but could not for a minute think of getting along without the perforator."

Price, Complete, \$65.00



THE H. C. HANSEN TYPE FOUNDRY



MONITOR HEAVY PERFORATOR

The Monitor Extra Heavy Perforator is very massive and strong in construction. The side guides for the head are supported by a cross brace above the head, thereby insuring a true and perfectly perpendicular motion. The head is connected with the operating shaft below by side rods, which are joined to head by means of a projected hub, on which the collar of the side rod operates. This removes any possible lateral motion or strain to the perforator head. The die plates are made of the highest grades of special tempered steel. Holes in die plate are 60 gauge, 15 to an inch. Every needle can be removed independently, and can be sharpened while in the machine. The machine is finely finished, is provided with suitable gauges and fine hardwood tables.

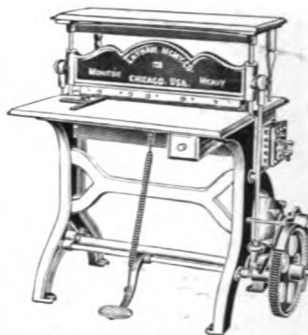

Monitor Extra Heavy Perforator

24-inch, Power Perforator, extra heavy.....	\$250.00		
28-inch, " " " "	275 00		
30-inch, " " " "	325.00		
20-inch, Foot Power, extra heavy.....	\$175.00	28-inch, Foot Power, extra heavy.....	\$225.00
24-inch, " " " "	200.00	30-inch, " " " "	275 00

Write for Net Prices

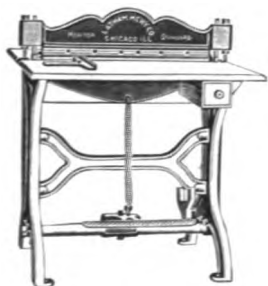

Monitor Standard Perforator

MONITOR STANDARD PERFORATOR

The Monitor Standard Perforator is constructed on the same principle as the heavy pattern, embodying the same recent improvements and conveniences. They will meet all requirements of general work and give entire satisfaction. Made for foot or steam power. The power device is very simple and quick in action. The machines are fully guaranteed in every respect. They are finely finished and provided with hardwood table and suitable gauges.

20-inch, Steam Power.....	\$125.00	20-inch, Foot Power.....	\$ 75.00
24-inch, " "	150.00	24-inch, " "	100.00
28-inch, " "	175.00	28-inch, " "	125.00
30-inch, " "	225.00	30-inch, " "	150.00

Write for Net Prices

ROSBACK PROGRESS POWER PERFORATOR

The dies are made of imported Jessop tool steel being 3-16 inch thickness, are hardened and guaranteed for five years. The punches are tool steel. The automatic delivery does away with one handling of the stock. The reclining table is adjustable to different angles, thus providing for various heights of piles. The feed gauge is an attachment for feeding sheets into the machine to be perforated when more than one line of perforation is desired. Without the feed gauge it would be necessary to run the sheets through the machine as many times as you have lines of perforation. The feed gauge is provided with stops which slide on a round shaft and can be slid and fastened at any desired position. Each one can be turned up and out of the way independently. The spaces can be made from 1/4 inch to 20 inches. The perforator is provided with a sectional adjustment to afford such different lengths of sections as desired. With our device the punches cannot slide by, and cause defective perforations. In case of a bent or injured punch, a single punch can be removed and a new one inserted in a moment's time without removal of other punches.

28-inch, Progress, Heavy, Steam Power.....	\$275.00
30-inch, " " " "	300.00

Write for Net Prices

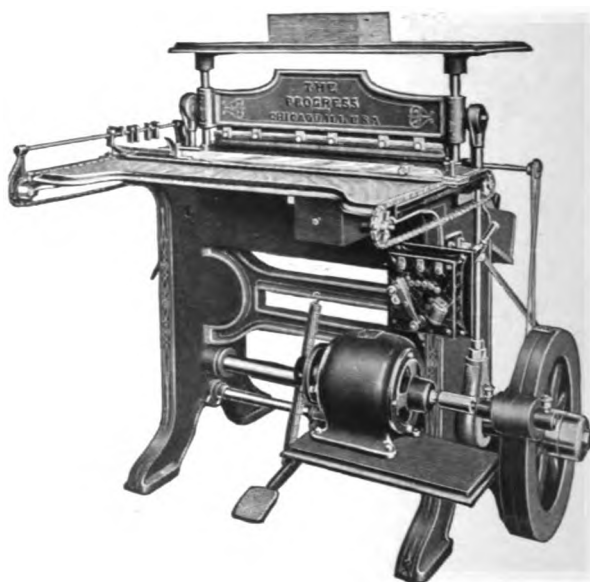

Extra Heavy Progress Steam Power Perforator

THE H. C. HANSEN TYPE FOUNDRY



30-Inch Iron Frame Shears—Style A

30-INCH IRON FRAME SHEARS

STYLE A

The 30-Inch Iron Frame Shears are adaptable for use of fancy leather goods and picture frame manufacturers as well as for the cutting of all kinds of cardboard, cloth, felt, paper, etc.

Price, without Spring Gauge.....\$75.00
 With Spring Gauge 83.00

Write for net prices and information on other sizes and styles.

THE ANDERSON BUNDLING PRESS

The range of work is from 3 x 6 inches to 10 x 12 inches, and larger if boards are used at each end of the bundle. It has a patent releasing device, a novel and very important feature. Made of the best material throughout. The gears are compounded so a pressure of 10,000 lbs. is easily obtained with the least exertion on the part of the operator. Weight, 700 pounds. Write for net prices.

Price.....\$125.00

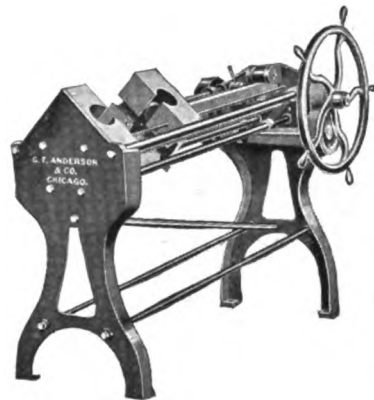

The Anderson Bundling Press



New Model Perforator

THE NEW MODEL PERFORATOR

The New Model will perforate a row of holes of any length up to 22 inches without removing any needles. The system of gauges is most comprehensive and adjustments can be made to the hundredth part of an inch. Perforator pins can be quickly removed or replaced. Extra pins 30 cents per hundred.

Price.....\$75.00

ROSBACK ROTARY PERFORATOR

Designed to do strictly up-to-date work, do it rapidly and at the smallest cost. It makes the slot hole and also the knife cut perforation; will score, trim and crimp, all at the same time or separately as desired. It is furnished with both styles of perforating heads. Automatic feed.

Price.....\$400.00

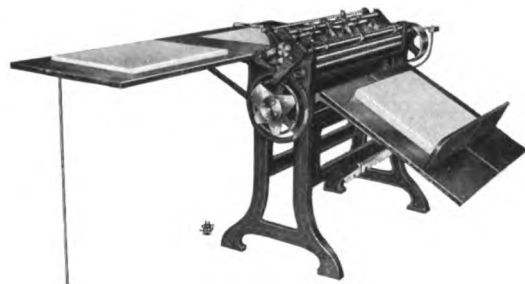

Rosback Rotary Perforator

ROSBACK ROTARY CRIMPING MACHINE

For crimping loose leaf ledger sheets rapidly and in first-class manner. Twenty-four teeth in each head so that any desired number of crimps may be made by simply shifting heads to engage a certain number of teeth. The machine will take in a full 28-inch sheet. Capacity rests alone with operator. Operates by power and will run continuously if desired. Price, \$105.00

THE H. C. HANSEN TYPE FOUNDRY



Rosback Perforator

ROSBACK PERFORATORS

These machines are very strongly built. Punches are of steel, perfectly round and straight, and make a clean perforation. They are placed directly under the center of the head which insures a perfectly perpendicular motion without tilt. Punches are independent of each other and can be removed and renewed without disturbing the others. Every machine is furnished with a file for sharpening punches. Bed is very heavy and insures perfect rigidity under any possible strain. Strippers are 3/8 inch thick and in one piece. Sliding steel plates, easily moved by the loosening of thumb screws, permit the operator to perforate just as much of the sheet as is desired. This is essential when perforating checks, etc.

EXTRA HEAVY HARD DIE ROSBACK PERFORATORS

15-Inch, Foot Power.....	\$ 85.00	28-Inch, Foot Power.....	\$150.00
20-Inch, " "	100.00	24-Inch, Steam Power.....	125.00
24-Inch, " "	125.00	28-Inch, " "	200.00
	10-Inch, Hand Power.....		\$50.00

REGULAR ROSBACK PERFORATORS

15-Inch, Foot Power.....	\$ 60.00	28-Inch, Foot Power.....	\$125.00
20-Inch, " "	75.00	24-Inch, Steam Power.....	150.00
24-Inch, " "	100.00	28-Inch, " "	175.00
	10-Inch, Hand Power.....		\$35.00

MONITOR MULTIPLEX PUNCH

Built on correct mechanical principles, and of the best grades of material. It is very heavy, solid and substantial. The combined punch and die heads for special punching are made of one solid casting, embracing the upper and lower dies. The combined head slides in groove to desired position, locked instantly by a lever, and requires no adjustment whatever. With the separate punch head and die block holes can be punched in any part of a 30 x 44 inch sheet, through about one-half inch of paper, making perfectly true and smooth perforations which can be spaced from 1 1/2 inches to 30 inches apart, and from one to twenty made at each operation.

- Machine complete, with 4 heads and upper and lower round dies (standard sizes) ..\$250.00
- Extra Round Hole Punches and Dies, less than 3/8-inch in diameter, per set..... 2.50
- Special Punches and Dies, including guide, stock sizes, each..... 7.50
- Combined Punch and Die Head (or holders) each..... 5.00
- Special Dies and Punches for loose leaf work made to order.

Write for Net Prices.

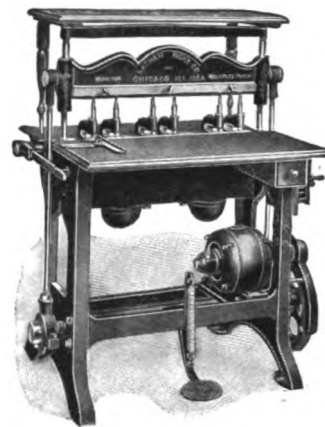

Monitor Multiplex Punch

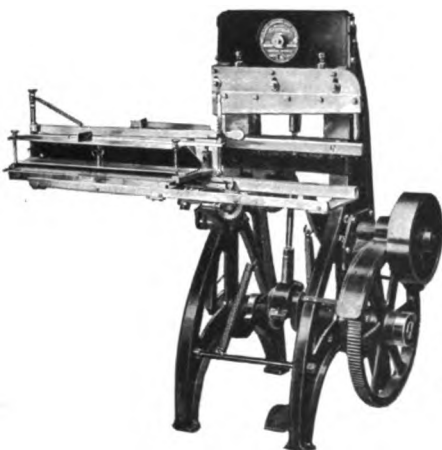

Rosback Automatic Index Cutting Machine

ROSBACK AUTOMATIC INDEX CUTTING MACHINE

This machine makes the indexing of blank books, directories, catalogs, loose leaves, etc., one of the most simple things in the bindery. The spacing is done entirely automatically and any length of space from 3-16 to 2 1/4 inches may be cut. Change of spacing can be made in two seconds and no change of racks or parts is required. The machine will cut anything from a vest pocket memorandum book to a 20-inch ledger. Depth of cut can be made as desired, from 1-8 to 2 inches by an adjustable receding gauge. The number of leaves to be cut for each letter is shown you by the automatic indicator or dial which revolves. The construction of this machine is strictly first-class, and all materials the best. Every machine guaranteed.

Prices on application.



THE BROWN & CARVER PAPER CUTTERS

AUTOMATIC CLAMP AND FOOT TREADLE POWER PAPER CUTTER

The Brown & Carver Automatic Cutters have been perfected so they will cut as accurately as the Brown & Carver Hand Clamp Cutters, and are absolutely unbreakable. The mechanism of these machines is simple and there are few wearing parts. They do not require frequent adjusting. The clamping pressure is applied on the principle of the Brown & Carver Hand Clamp. It is independent of the knife, is powerful and reliable, and can be instantly varied by shifting a lever within easy reach of the operator. With a speed of thirty cuts per minute the clamp descends gently upon the stock and packs the pile without jarring sheets out of position. The automatic pressure is then applied. The pile is held under uniform pressure throughout the stroke of the knife, and, as the three operations of packing, clamping and cutting are distinct and separate, and are performed at different times during the revolution of the machine, the belt power is never called upon for more than one operation at a time and consequently the Brown & Carver Cutters take the least power to operate. Further particulars and specifications on application.

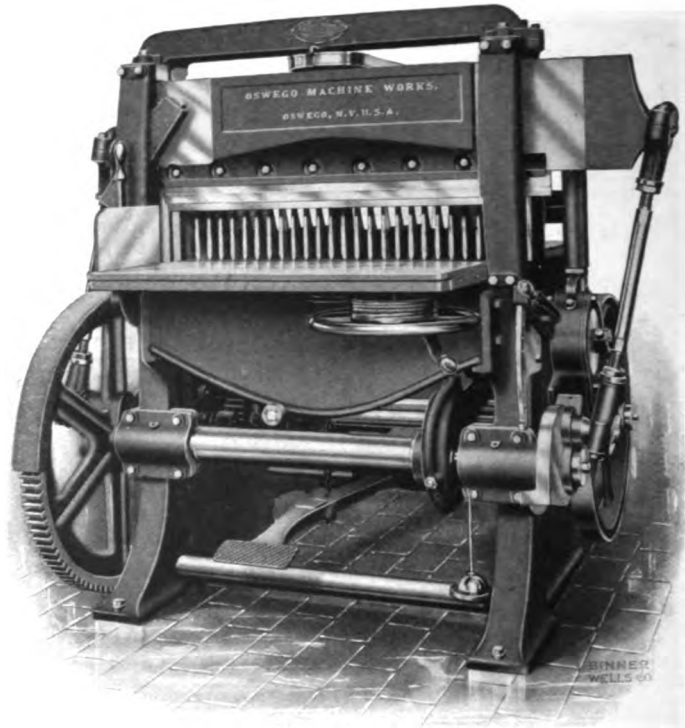

34-inch, weight 5,200 pounds.....	\$ 750.00	63-inch, weight 12,650 pounds.....	\$1850.00
38-inch, weight 5,900 pounds.....	875.00	68-inch, weight 14,450 pounds.....	2150.00
44-inch, weight 6,600 pounds.....	1075.00	74-inch, weight 16,650 pounds.....	2600.00
50-inch, weight 7,500 pounds.....	1300.00	84-inch, weight 19,150 pounds.....	3000.00
57-inch, weight 10,150 pounds.....	1550.00		

Hand clamp attachment for automatic clamp cutters, \$50.00 extra, less discount.
Plain clamp and plain back gauge, not interlocking, cutting up to 3½ inches, and plain table, special lower prices.

Information regarding the new Power Cutter called the "Ontario" furnished on request.

THE BROWN & CARVER SEMI-AUTO CUTTERS

With Foot Treadle and Hand Clamp



The clamp on these machines may be operated as on the regular Brown & Carver Hand Clamp Cutters, or it may be brought down to the work quickly by treadle, and will lock automatically on the work or return to the top, as desired. A partial turn of the hand clamp wheel will give full clamping pressure, and a partial turn in reverse while the foot is held on treadle will release the clamp so it will rise automatically to the top. Work may be cut up to ¾ inch wide, and the knife has a rise of 6½ inches. The back gauge is in three parts, and, when split, the sections form a side gauge so that work can be cut near center of knife as well as at the side of machine. The back gauge is close to side gauge for small work. The clamp is provided with a flat removable

plate for fine work which might otherwise be marred by clamp fingers. The knife can be instantly adjusted for level or wear by turn of the connecting rod.

WITH TREADLE AND CABLE GAUGE MOVEMENT

34-inch, weight 4,600 pounds.....	\$665.00	44-inch, weight 6,100 pounds.....	\$ 990.00
38-inch, weight 5,300 pounds.....	790.00	50-inch, weight 6,900 pounds.....	1190.00

BROWN & CARVER HAND CLAMP CUTTERS, SCREW GAUGE MOVEMENT AND WITHOUT TREADLE

34-inch, weight 4,500 pounds.....	\$ 625.00	63-inch, weight 10,500 pounds.....	\$1700.00
38-inch, weight 5,200 pounds.....	750.00	65-inch, weight 11,400 pounds.....	1820.00
44-inch, weight 6,000 pounds.....	950.00	68-inch, weight 12,300 pounds.....	2000.00
50-inch, weight 6,800 pounds.....	1150.00	74-inch, weight 14,500 pounds.....	2400.00
54-inch, weight 7,600 pounds.....	1290.00	84-inch, weight 16,000 pounds.....	2800.00
57-inch, weight 8,200 pounds.....	1400.00		

Write for Net Selling Prices of Brown & Carver Machinery.

THE H. C. HANSEN TYPE FOUNDRY



POWER PAPER CUTTERS



OSWEGO AUTOMATIC CLAMP CUTTER

Foot Treadle and Cable Gauge

The pressure of the automatic clamp is sufficient to clamp and cut accurately the hardest stock. The knife makes 27 cuts a minute. Production, therefore, is limited only by the ability of the operator to keep pace with the machine. Work is cut up to 1/2 inch wide.

Size, 32-inch. Weight, 3,600 pounds. List Price.....\$570.00

Hand Clamp Attachment for these cutters, \$65.00 extra, less discount.

OSWEGO SEMI-AUTO POWER CUTTERS

Hand Clamp, with Foot Treadle and Cable Gauge

Guaranteed rigid, powerful, fast and accurate. The clamp on these machines may be operated as on the regular Oswego Hand Clamp Cutters, or it may be brought down to the work quickly by treadle, and will lock automatically on the work or return to the top, as desired. A partial turn of the hand clamp wheel will give full clamping pressure, and a partial turn in reverse while foot is held on treadle will release the clamp so it will rise automatically to the top. These cutters are speeded to 27 cuts a minute. The clamp and back gauge interlock, allowing work to be cut up to 1/2 inch. The knife is bolted solidly to the bar and is instantly adjusted by a turn of the connecting rod at right and eccentric lever at left.



26-inch, weight 2,300 pounds.....\$405.00	32-inch, weight 2,700 pounds.....\$490.00
30-inch, weight 2,600 pounds..... 430.00	36-inch, weight 2,800 pounds..... 600.00

OSWEGO POWER CUTTERS (HAND CLAMP) WITHOUT TREADLE AND WITH SCREW GAUGE MOVEMENT

26-inch, weight 2,000 pounds.....\$330.00	32-inch, weight 2,400 pounds.....\$415.00
30-inch, weight 2,300 pounds..... 355.00	36-inch, weight 2,600 pounds..... 530.00

OSWEGO HAND AND POWER CUTTERS (HAND CLAMP) WITHOUT TREADLE, WITH SCREW GAUGE MOVEMENT

26-inch, weight 2,100 pounds.....\$350.00	33-inch, weight 2,600 pounds.....\$510.00
30-inch, weight 2,400 pounds..... 380.00	36-inch, weight 2,700 pounds..... 555.00
32-inch, weight 2,500 pounds..... 445.00	

Each of the above cutters furnished complete with knife, oil can and wrenches, delivered skidded and boxed f.o.b. cars Oswego, N. Y. No overhead fixtures of any kind are included. **Write for Net Selling Prices.**

THE NATIONAL SELF-CLAMPING CUTTER

Each size is made in several styles as shown in table below. The back gauge is moved by an accurately graduated steel band passing over a geared wheel at front of table directly under the eye of the operator. A powerful clamp is provided by which the gauge can be instantly locked. The back gauge can be furnished plain, or interlocking which allows cuts to be made as narrow as 1/8 inch. The back gauge can be furnished in one or three parts. Accurate side gauges extend both front and back from the knife. The automatic throw-off is positive in its action and so arranged that the accidental starting of the machine is impossible. The round cutting stick presents much more surface than a square stick, consequently it lasts much longer. The stick is held firmly by a patented device which prevents its slipping and turning when in use. To overcome momentum and as an additional safeguard a powerful automatic brake has been provided, which is so designed that it is only on when the clutch is off.

32-INCH MACHINES

Plain Self-Clamp weight 3,600 pounds.....\$600.00
Self and Foot Clamp weight 3,800 pounds..... 675.00
Self and Hand Clamp weight 3,900 pounds..... 700.00
Self, Hand and Foot Clamp, weight 3,950 pounds..... 750.00

36-INCH MACHINES

Plain Self-Clamp weight 3,900 pounds.....\$725.00
Self and Foot Clamp weight 4,100 pounds..... 800.00
Self and Hand Clamp weight 4,200 pounds..... 825.00
Self, Hand and Foot Clamp, weight 4,250 pounds..... 875.00

40-INCH MACHINES

Plain Self-Clamp weight 4,200 pounds.....\$ 850.00
Self and Foot Clamp weight 4,400 pounds..... 925.00
Self and Hand Clamp weight 4,500 pounds..... 950.00
Self, Hand and Foot Clamp, weight 4,550 pounds..... 1000.00

44-inch Machines: Self Clamp; Self and Foot Clamp; Self and Hand Clamp; Self, Hand and Foot Clamp. Prices and discounts on application.

Write for Net Selling Prices.

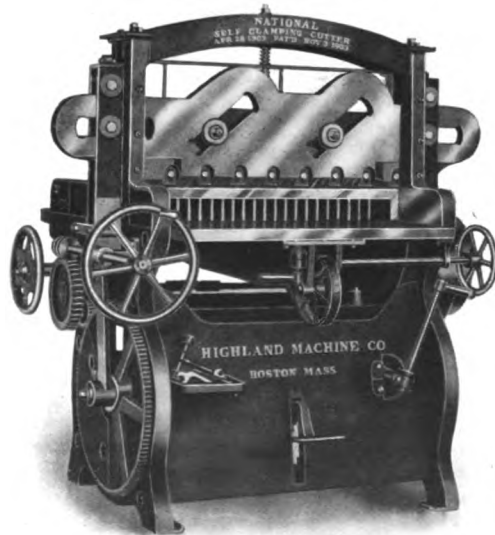

The National Self-Clamping Cutter

THE H. C. HANSEN TYPE FOUNDRY



LEVER PAPER CUTTERS

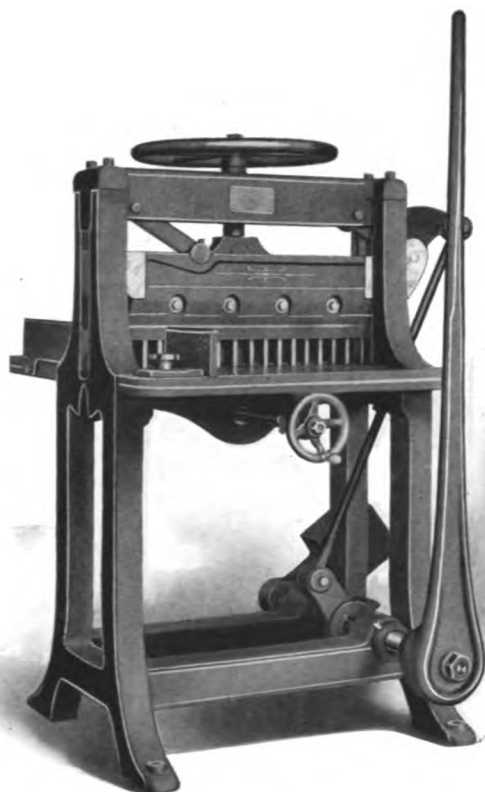

Chandler & Price Paper Cutter

THE CHANDLER & PRICE PAPER CUTTER

It is heavier than other cutters of its size, the extra metal being distributed to withstand strain and springing when worked to fullest capacity. The smooth working quality due to this staunchness has made it a very popular machine. The legs, braces, table and knife bar are of very heavy pattern. The cutter is perfectly counterbalanced, with weight and lever easily and quickly adjustable to suit each operator's convenience. The extra large hand-wheel makes clamping quick and easy. The clamp fingers have a broad surface, thus saving fine stock from creasing. All gauges are accurately squared with the knife and when in place are rigid and true. The back gauge extends to within an inch of the side gauge. All parts are strictly interchangeable.

23-inch, weight 950 pounds.....	\$100.00
26-inch, weight 1,100 pounds.....	130.00
30-inch, weight 1,600 pounds.....	175.00

THE PEERLESS GEM LEVER CUTTER

The frames are very strong, with double braces. The knife bars are thick and carefully adjusted in the slots, which are provided with gibs and adjusting screws to take up any possible wear. The leverage is perfect and the cutting is very easy; the knife returns to its original position with the least possible exertion owing to the perfect counterbalance, which is within the machine out of the way.

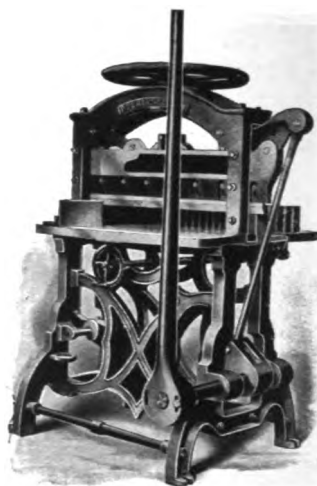

Peerless Gem Paper Cutter

All sizes are furnished with intersecting, adjustable back gauges and will cut to a very narrow margin. The back gauges on the two larger sizes are split. Side gauges are furnished on all sizes.

23-inch, weight 750 pounds.....	\$100.00	30-inch, weight 1,400 pounds.....	\$175.00
25-inch, weight 850 pounds.....	125.00	32-inch, weight 1,450 pounds.....	200.00

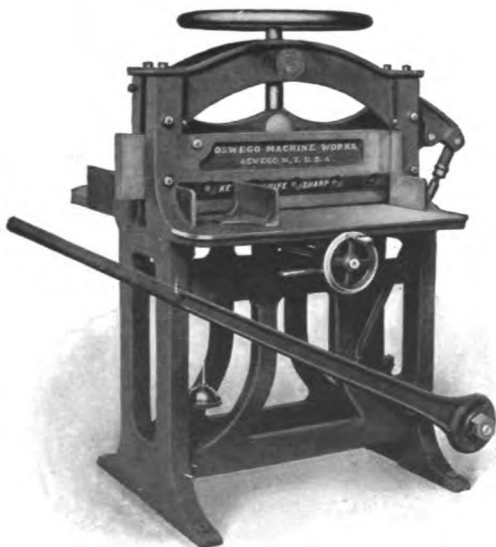

Oswego Lever Paper Cutter

OSWEGO LEVER PAPER CUTTERS

An exceptionally heavy, durable machine, made in four sizes. The finger clamp and back gauge allow work to be cut as narrow as $\frac{1}{4}$ inch. The table is plain (not grooved); front scored in $\frac{1}{4}$ inch squares with brass rule graduated to sixteenths of an inch, back table ruled to sixteenths of an inch. Back gauges are in two parts which may be offset if desired. Extra long back side gauge on left hand side (may be put on right hand side). Detachable front side gauge can be adjusted out and in at different angles. Clamp rises $3\frac{1}{2}$ inches on 30- and 32-inch sizes, 3 inches on 23- and 26-inch sizes.

23-inch, weight 1,200 pounds.....	\$110.00
26-inch, weight 1,400 pounds.....	130.00
30-inch, weight 1,650 pounds.....	175.00
32-inch, weight 1,800 pounds.....	200.00

Write for net selling prices on Lever Paper Cutters shown on this page

THE H. C. HANSEN TYPE FOUNDRY



BENCH LEVER CUTTERS

MORGANS & WILCOX BENCH CUTTERS

These cutters are of improved design and modern construction. The clamp and back gauge are interlocking and cuts may be gauged as narrow as $\frac{1}{4}$ inch. The stroke of the knife is positive, and the leverage being very powerful, heavy cutting is surprisingly easy.

16-inch \$50.00
 19-inch 65.00

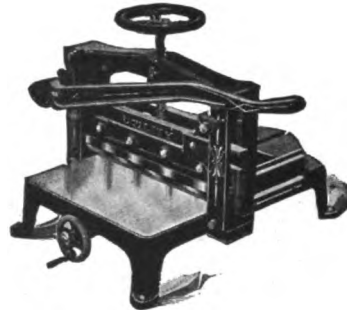
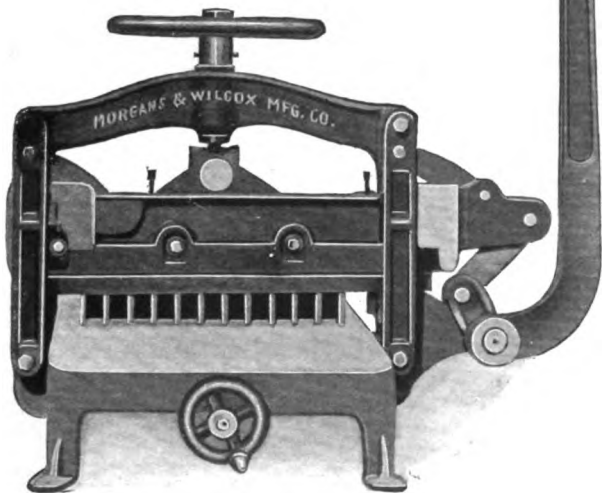

UTILITY BENCH CUTTERS

One of the handiest and most useful paper cutters on the market. It will save its cost in a very short time as it may be used for cutting all small work such as letter heads, note heads, circulars, cards, etc., thus saving the constant wear upon your large cutter.

16-inch \$50.00
 18-inch 60.00
 Iron Stand for either size 7.00

OSWEGO BENCH CUTTERS

A substantially built, easy working machine. The back gauge and clamp are finger patterns. The back gauge has a locking device to hold it in any position. The gauge runs back the full size of machine and cuts as narrow as $\frac{1}{4}$ inch. The clamp rises $2\frac{1}{2}$ inches. The 19-inch size is furnished also with an iron floor stand.

16-inch. Weight 340 lbs. \$60.00
 19-inch. " 375 " 75.00
 19-inch. " 575 " on iron stand... 85.00



LIEB LABEL CUTTING GAUGE

The only satisfactory gauge for cutting narrow strips on paper cutters. The sections are made of brass, and they are kept in an upright position by means of springs placed between each link. Even paper cutters having interlocking back gauge and clamp cannot handle all classes of work without a label gauge. The Lieb gauge is the most accurate. They can be supplied in any length desired, but minimum charge is for gauge of ten links.

Price, with 10 links \$12.00
 Additional links, each 1.25

CUTTING STICKS

Cutting sticks furnished for all power, lever and bench cutters. In ordering be sure to mention name and size of machine, also style of stick (whether square, round or octagon) and dimensions if possible. Best quality of sticks furnished at lowest prevailing prices. Popular styles and sizes carried in stock.

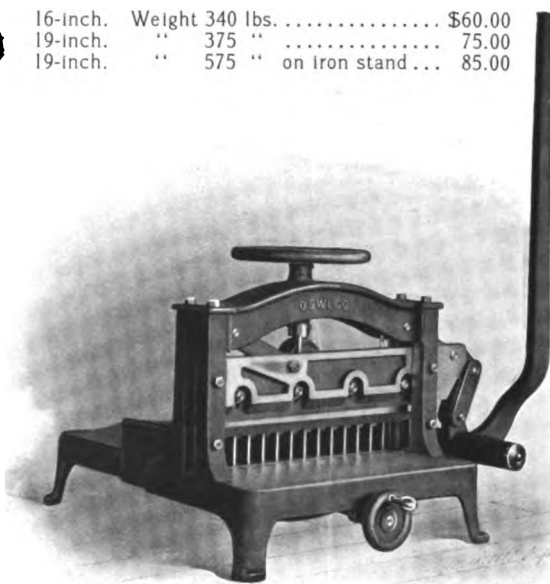

THE H. C. HANSEN TYPE FOUNDRY



GALLY UNIVERSAL CUTTER AND CREASER

For paper box and novelty manufacturers the Universal press has no equal. The cutting form can be placed out of center without injury to the cutting rule or detriment to the work. Mr. Gally's latest patent improvement on these presses holds the platen to register on an unbalanced form. This is a very important feature, as is fully understood by all those engaged in the manufacture of paper boxes and similar articles.

	Size of Bed	Inside Chase	Shipping Weight	Price
No. 1	22 x 31 $\frac{1}{2}$	20 x 30	4,800	\$465.00
No. 1 $\frac{1}{2}$	24 $\frac{1}{2}$ x 31 $\frac{1}{2}$	22 $\frac{1}{2}$ x 30 $\frac{1}{2}$	4,900	525.00
No. 2	25 x 33	23 $\frac{1}{2}$ x 31	5,100	590.00
No. 3	27 $\frac{1}{2}$ x 41 $\frac{1}{2}$	27 x 40	6,500	790.00
No. 4	31 x 45 $\frac{1}{2}$	30 x 44	7,400	950.00

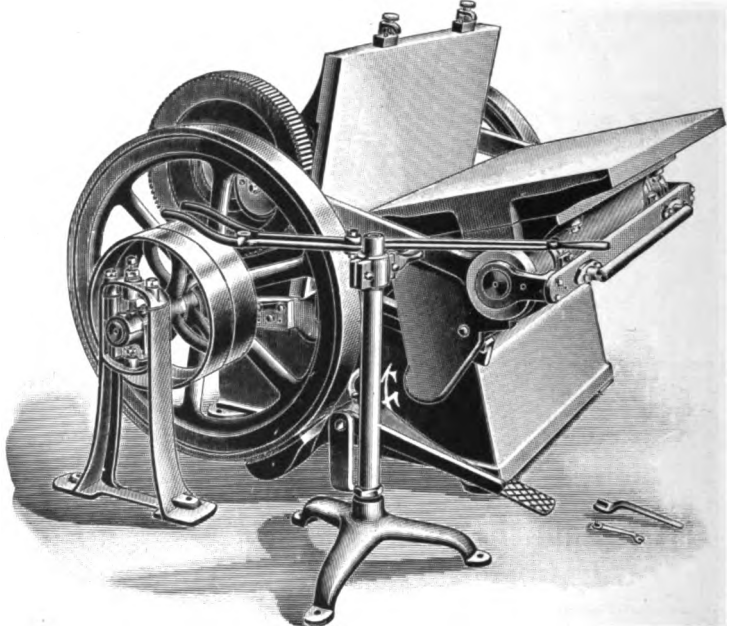

Universal Cutter and Creaser No. 4

COLT'S ARMORY CUTTING AND SCORING PRESS

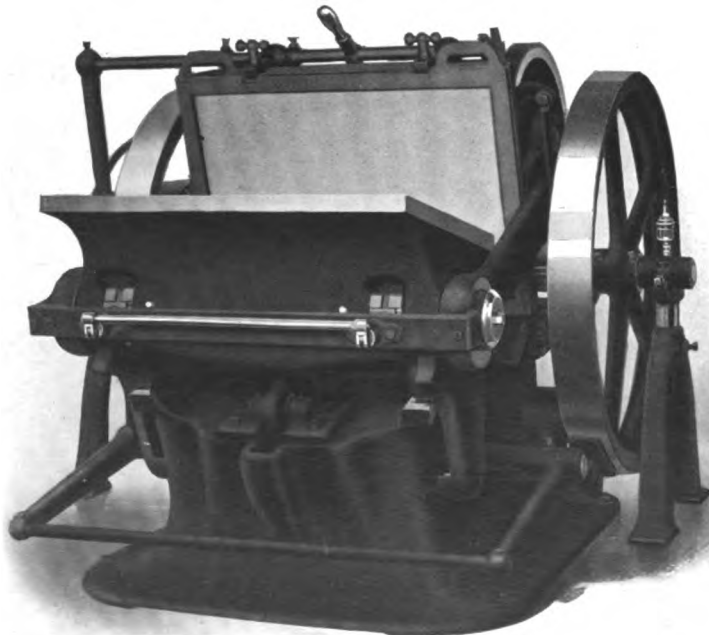

Colt's Armory Cutting and Scoring Press

This press is double geared; has a fly-wheel on each side, thereby transmitting the Impressional stress in the most direct manner possible. The weight and strength of the frame and platen have been considerably increased, adapting the press to heavier work than originally contemplated. The impression teeth of the gears are forged steel, formed in separate sections and fused into the rims of the wheels. The pinions are cut from steel forging. Feed tables and standards are furnished with each press.

Style 4. 20 x 30 inches inside chase, shipping weight 5,315 pounds \$585.00

Style 5. 20 x 30 inches inside chase, shipping weight 5,715 pounds \$615.00

New Special Model, crank-action cutting and scoring press with lever impression trip, self-contained belt shifter and brakes and platen friction safety lugs. Size 28 x 41 inches inside of steel chase.....\$1000.00

More complete data will be furnished upon request.

Write for Net Selling Prices.

THE H. C. HANSEN TYPE FOUNDRY



BERKSHIRE ORNAMENTS AND INITIALS

(Electrotypes) Made Only in Characters Shown Order by Number Originated by H. C. Hansen



No. 177. \$0.50



No. 477. \$0.60

No. 478. \$0.60

No. 476. \$0.60

6-POINT BORDER NO. 1450. 60 INCHES \$1.50

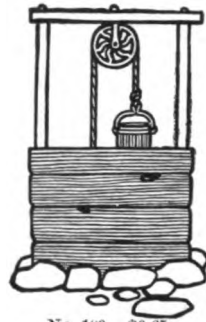

No. 180. \$0.65



No. 188



No. 178. \$0.50

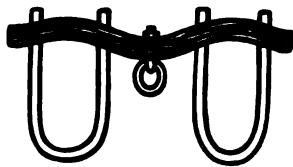

No. 179. \$0.50



No. 475. \$0.75



No. 189



No. 192



No. 185

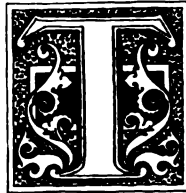

No. 184

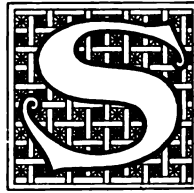

No. 183

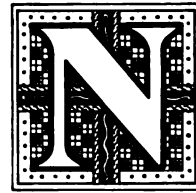

No. 186



No. 191

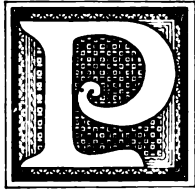

No. 187



No. 186



No. 196

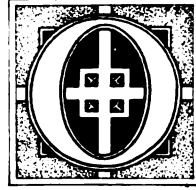

No. 190



No. 184
Mortised

The Initials shown on this page are made only in the characters shown
Price, 60c. each
Order by Number

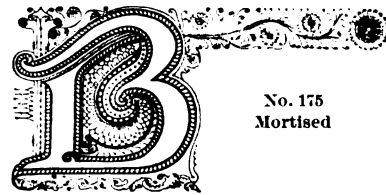

No. 175
Mortised

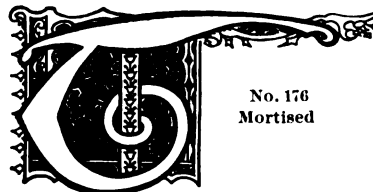

No. 176
Mortised

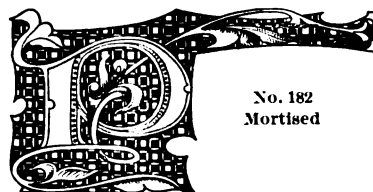

No. 182
Mortised

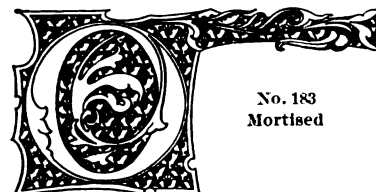

No. 183
Mortised

12-POINT ROYAL BORDER. 54 INCHES \$1.50

THE H. C. HANSEN TYPE FOUNDRY



New Cambridge

60-Point

3A \$5.50 5a \$3.50 \$9.30

NEW DESIGN
Typographic 5

These Striking and Desirable Type Faces are now in preparation. Specimen Sheets will be issued upon their completion. Watch for them

Boston Italic

60-Point

3A \$7.00 4a \$5.00 \$12.00

CAMDEN
Golf club

THE H. C. HANSEN TYPE FOUNDRY

BOSTON ITALIC

***A Very Distinctive and
Striking Type Series
valuable to the Printer
and Advertiser***

***THE
H. C. HANSEN TYPE
FOUNDRY
BOSTON and NEW YORK***

6-PT. UNIQUE BORDER. 60 INCHES \$1.50

Boston Italic Series

Standard Line. Unit Set

36-Point

3A \$3.00 5a \$2.40 \$5.40

GREAT SPECIAL SALE
It Pays to Advertise 8

Fast Color
HOSIERY



Men's

Color

Size

Lot

Grade

Thomas
Knitting Mills
CLEVELAND, O.

18-Point

8A \$1.70 14a \$1.80 \$3.50

THE GREAT BARGAIN STORE
Big Display of Choice Fabrics
Special price for early buyers

24-Point

6A \$1.85 10a \$1.85 \$3.70

RETURN OF MAGNATES
Bring Choice Treasures
Customs Officials Avoid

30-Point

4A \$2.30 6a \$2.10 \$4.40

PUBLIC MARKET
Buy Fresh Meats
Daily Bargains 5

48-Point

3A \$5.10 4a \$3.40 \$8.50

SPRING TONICS
New and Catchy

THE H. G. HANSEN TYPE FOUNDRY

Boston Italic Series

Standard Line. Unit Set

***The best Birthday or Holiday Gift
FOR EVERYONE***

"A FAULTLESS MINIATURE IN WORDS"

***Molly
Make-Believe***

By

ELEANOR HALLOWELL ABBOTT

"A deliciously humorous love story, with the oddest plot imaginable"

"Brimful of ginger and joy, the ginger being sugared"

Clever Pictures

Only \$1.00 Net

12 PT. UNION BORDER NO. 4. 54 INCHES, \$1.50

60-Point

3A \$7.00 4a \$5.00 \$12.00

***REAP CROPS
Stock Market***

THE H. O. HANSEN TYPE FOUNDRY

Boston Italic Series

Standard Line. Unit Set

36-Point

3A \$3.00 5a \$2.40 \$5.40

***GREAT SPECIAL SALE
It Pays to Advertise 8***

***Fast Color
HOSIERY***



Men's

Color

Size

Lot

Grade

***Thomas
Knitting Mills
CLEVELAND, O.***

18-Point

8A \$1.70 14a \$1.80 \$3.50

***THE GREAT BARGAIN STORE
Big Display of Choice Fabrics
Special price for early buyers***

24-Point

6A \$1.85 10a \$1.85 \$3.70

***RETURN OF MAGNATES
Bring Choice Treasures
Customs Officials Avoid***

30-Point

4A \$2.30 6a \$2.10 \$4.40

***PUBLIC MARKET
Buy Fresh Meats
Daily Bargains 5***

48-Point

3A \$5.10 4a \$3.40 \$8.50

***SPRING TONICS
New and Catchy***

THE H. G. HANSEN TYPE FOUNDRY

Boston Italic Series

Standard Line. Unit Set

***The best Birthday or Holiday Gift
FOR EVERYONE***

"A FAULTLESS MINIATURE IN WORDS"

***Molly
Make-Believe***

By

ELEANOR HALLOWELL ABBOTT

"A deliciously humorous love story, with the oddest plot imaginable"

"Brimful of ginger and joy, the ginger being sugared"

Clever Pictures

Only \$1.00 Net

12 PT. UNION BORDER NO. 4. 54 INCHES. \$1.50

60-Point

3A \$7.00 4a \$5.00 \$12.00

***REAP CROPS
Stock Market***

THE H. G. HANSEN TYPE FOUNDRY

Keep in a Cool Dry Place!

For

Via

**From NORRIS & CHILDS
Chemists**

97 Highland St. Utica, N.Y.

**Boston
Italic**

Registers with Gothic
Italic for printing in
colors

New England Products



The result of New England Enterprise and Ingenuity, are known the world over for their high quality and reliability. "Made in New England" stands for superior quality, and the printers' supply line is no exception, for the best quality

Standard Lino Type

Borders, Ornaments, Brass Rule and Printing Office Supplies are made in Boston by New England's only complete manufacturing Type Foundry

***The H. C. Hansen Type
Foundry***

AN INDEPENDENT TYPE FOUNDRY

ESTABLISHED 1872



ACME BINDER No. 1

The Acme Binder No. 1 is a lever action wire staple binder, strong and simple in construction. It holds 100 heavy wire staples, binds to 1/4 inch and is equipped with patented anti-clogging device, and can be fastened to table or platform.

Price.....\$6.00

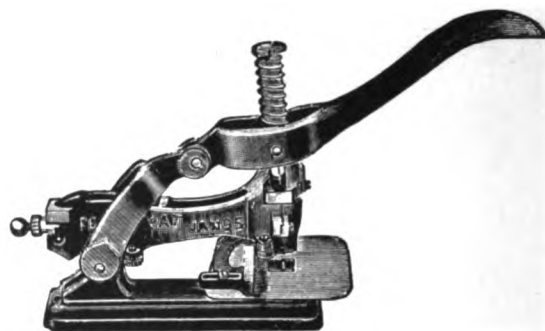

Acme Binder No. 1

THE MORSE ADJUSTABLE GAUGE PIN

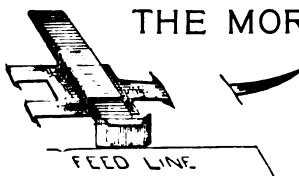

Simple, durable, accurate and easily adjustable.

Per 2 sets (6 pins)....\$1.00

NEW DRAPER ADJUSTABLE COMPOSING STICK



Draper Adjustable Composing Stick

This stick is simple, easily adjusted, accurate. Any desired number of picas or half picas can be instantly obtained by sliding the knee in the usual way until the pin, which is made of special spring steel, engages the correct measure. Any odd measure may also be obtained by not engaging the pin and slot. The principle of a round steel pin engaging a V slot insures absolute accuracy which wear does not effect.

6-Inch.....\$1.40	10-Inch.....\$1.85	14-Inch.....\$2.30	18-Inch.....\$2.75
8-Inch.....1.60	12-Inch.....2.10	16-Inch.....2.50	20-Inch.....3.00

Made in 2-inch, 2 1/4-inch and 2 1/2-inch widths at same price. Nickel plating, 35 cents extra.

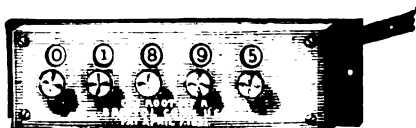

Elm City Counter



Bristol Counter

COUNTERS

These Counters are well made and efficient. Suitable for all printers' requirements

No. 5 Bristol Counter.....\$10.00	No. 5 Elm City Counter.....\$10.00
No. 5 Pequabuck Lever Style Counter.....\$7.50	



Hansen's Beveled Quads in Quarter-size Case

MODEL B DURANT COUNTER

Designed especially for job press use. All parts are of steel, made with dies, except for brass bearings and unit gear. Size 4"x2"x1 1/2". Weight, 1 1/2 pounds.

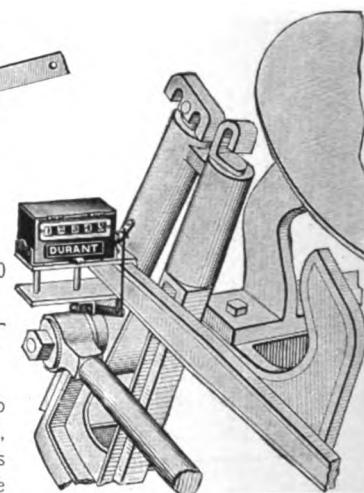

Model B Durant Counter attached to press

Price.....\$6.50

Attachments for Gordon Press, \$1.25

QUARTER-CASE HANSEN'S BEVELED QUADS

Special Font Hansen's Beveled Quads in Quarter-size case containing 45°, 54° and 60° (See page 256) complete with case.....\$12.00

MARSH HYGIENIC RUBBER FINGER PAD

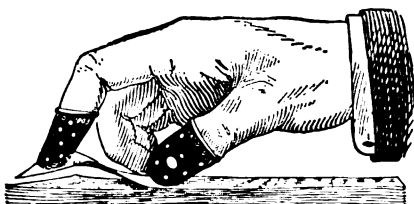

Marsh Hygienic Finger Pad

For counting money, assorting checks or mail, turning leaves, overhauling files, handling money or paper of any character. Indispensable to bookbinders and pressfeeders. Each \$0.10

Send for card showing different sizes

SPONGES

Extra heavy printers' sponges
No. 1, \$0.75 No. 2, \$1.00 No. 3, \$1.50



Printers' Sponge

THE H. C. HANSEN TYPE FOUNDRY

HANSEN'S COMPLETE LEAD and RULE CUTTER

(PATENT PENDING)

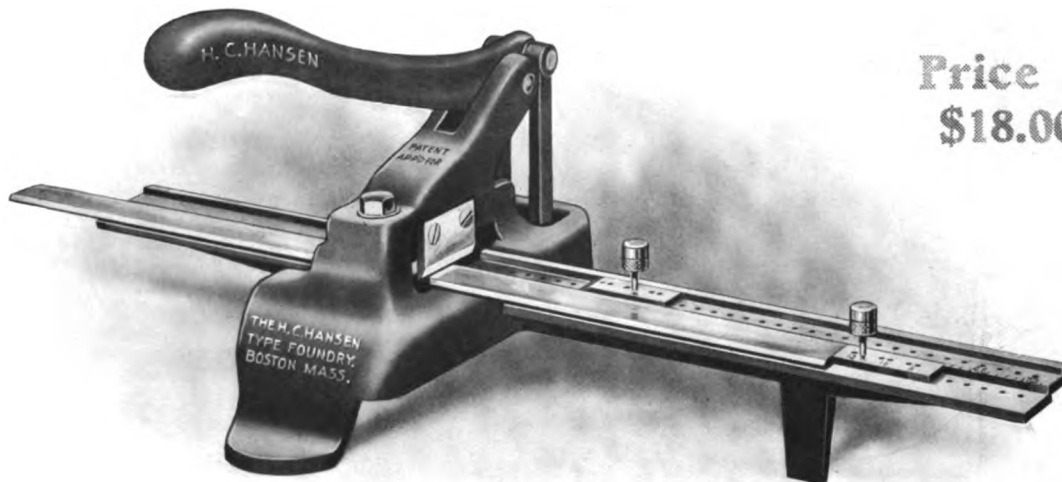

Price
\$18.00

This cut illustrates
the cutting of a
12-pt. column rule

TWENTIETH CENTURY INVENTION BY THE LEADING INVENTOR OF
TYPE FOUNDRY DEVICES

AN entirely new mechanism throughout.
Works differently, acts differently than any other cutter.
Cuts brass rule from the smallest thickness to 12-point [■] brass and leaves pieces absolutely without any bend.
Saves the price of a power saw—and \$100 is worth saving in most printing offices.
The gauges are on the *right* and *not on the left*.
The left side is free and clear for cutting any length of leads or brass rule.
Cuts any graduation from 2, 4, 6, 8, 10 and 12 points to 72 ems (12-point) in length.
Gauges can be set positive in an instant giving 2-pt. variations from 1 em to 72 ems 12-point.
Just think of the advantage of cutting any thickness from a tissue paper to 12-point brass just a 2-point longer than finished length to allow for mitering.
Cutting a 12-point thickness requires but very little strength.
Contains only two knives and those are perfectly straight, without any notches, for cutting metal or brass.
This cutter occupies a space of only 11 x 21 inches.
The advantages of this cutter are as great as the advantages of the Hansen Complete Miterer.
We stand back of the above statements and further particulars will be sent on application.

THE H. C. HANSEN TYPE FOUNDRY, Boston

HANSEN'S SHADOWTYPE WILL STAND AN ALMOST UNLIMITED NUMBER OF IMPRESSIONS WITHOUT LOSING THE SHARPNESS OF ITS SCREEN

THE H. C. HANSEN TYPE FOUNDRY

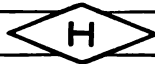

Halftone Type

HANSEN SHADOWTYPE. (Patent applied for)

STYLES OF SHADOWTYPE

**A Few
Popular
Faces**

Gothic Italic

VARIETY Beauty

*Gothic
Extended*

BANK note

*Medium Gothic
No. 7*

FIRST Shown

Mastodon

FINE Result

Cambridge

HALF tones

Tudor Black

Art Printers

Sylph Initials

G E R M



The H. C. Hansen Type Foundry

Boston, Mass.

New York City

THE H. C. HANSEN TYPE FOUNDRY

For Printers

Every year The H. C. Hansen Type Foundry brings forth many new and meritorious productions which enable the printer to obtain novel and artistic effects with the minimum amount of labor and without resorting to the expensive processes and the aggravating delays of photo-engraving.

Halftone Type

Here shown for the first time is, we believe, an innovation in type making which will be welcomed by both the printer and advertising man. Its range of usefulness is great. For a distinctive advertisement, an artistic cover page, or the thousand-and-one opportunities that occur in the production of high-grade job printing it will be found of great value. Its soft gray tone will often give a result as satisfactory as a job printed in two colors, thus saving much time and labor. Especially attractive when used in conjunction with Hansen's Halftone Brass Rule. At a moderate expense any type of suitable size and surface of face can be finished in halftone. *Shadowtype*

A RECENT INVENTION OF
H. C. HANSEN

ANY SUITABLE SIZE *and* FACE
OF TYPE CAN BE FINISHED IN
HALFTONE. IF INTERESTED,
WRITE FOR PRICES AND PAR-
TICULARS

**The H. C. Hansen
Type Foundry**

A B C

THE Sylph Initials
finished in half-
tone are a most
pleasing series for use
where a distinctive, soft
toned initial is desired

T R

The Music Store

PUBLISHED MONTHLY
FOR THE BENEFIT OF THE
MUSIC TRADE



Bates & Company
SOMERVILLE, MASS.

THE H. C. HANSEN TYPE FOUNDRY

BOOKS FOR PRINTERS AND ALLIED TRADES

"Gather Knowledge From Those Who Know"

BOOKBINDING. Edited by Paul N. Hasluck. 160 pages, cloth.....	\$0.50	ORDER BOOK AND RECORD OF COST. By H. G. Bishop. 100 leaves, providing room for entering 3000 jobs. Half-bound.....	\$3.00
BOOKBINDING AND THE CARE OF BOOKS By Douglas Cockerell. 317 pages, cloth.....	1.35	PRINTERS' INSURANCE PROTECTIVE INVENTORY SYSTEM. By Charles S. Brown. No. 1, for large job or newspaper offices, \$25; No. 2, for newspaper offices only, \$15; No. 3, for job offices only, \$15; No. 4, for small job and newspaper offices	10.00
BOOKBINDING FOR AMATEURS. By W. J. E. Crane. 184 pages, 156 illustrations, cloth.....	1.10	STARTING A PRINTING OFFICE. By R. C. Mallette. 88 pages, cloth.....	1.60
MANUAL OF THE ART OF BOOKBINDING By J. B. Nicholson. 317 pages, illustrated, cloth..	2.35	HANDBOOK OF LITHOGRAPHY. By David Cumming. 243 pages, illustrated, cloth.....	2.10
THE ART OF BOOKBINDING. By J. W. Zaehnsdorf. 200 pages, illustrated, eight plates, cloth.....	1.60	LITHOGRAPHIC SPECIMENS. Album Lithographique, part 20, \$1.50. American commercial specimens, first, second and third series, \$3.50 each. Modern Alphabets.....	3.50
CONCERNING TYPE. By A. S. Carnell. 64 pages, flexible cloth, vest-pocket size.....	.50	THE GRAMMAR OF LITHOGRAPHY. By W. D. Richmond. 254 pages, cloth.....	2.10
CORRECT COMPOSITION. By Theodore Low De Vinne, A.M. 476 pages, cloth.....	2.10	A POCKET COMPANION FOR LINOTYPE OPERATORS AND MACHINISTS. By S. Sandison. 36 pages, vest-pocket size.....	1.00
MODERN BOOK COMPOSITION. By Theodore Low De Vinne. 477 pages, illustrated, cloth.....	2.10	CORRECT KEYBOARD FINGERING. By John S. Thompson.....	.25
PLAIN PRINTING TYPES. By Theodore Low De Vinne, A.M. 403 pages, cloth.....	2.10	THE MECHANISM OF THE LINOTYPE. By John S. Thompson. Flexible leather, 3d edition..	2.00
THE PRACTICAL PRINTER. By H. G. Bishop. 200 pages, cloth.....	1.00	THE ART OF ENGRAVING. 200 illustrations, 200 pages.....	1.60
THE AMERICAN MANUAL OF TYPOGRAPHY 180 pages, 300 reproductions in color, heavy cover, cloth back, By express at expense of purchaser.....	4.00	THE BUILDING OF A BOOK. Edited by Frederick H. Hitchcock. 12mo, cloth, about 400 pages	2.20
TITLE-PAGES. By Theodore Low De Vinne, A.M. 485 pages, cloth.....	2.10	THE GRAPHIC ARTS AND CRAFTS YEAR BOOK. 300 pages, cloth.....	5.00
VEST-POCKET MANUAL OF PRINTING. 86 pages, vest-pocket size, bound in leather.....	.50	INKS, THEIR COMPOSITION AND MANUFACTURE. By C. Ainsworth Mitchell and T. C. Hepworth. 250 pages.....	2.60
A HANDBOOK OF ORNAMENT. By Franz Sales Meyer. 548 pages, 300 plates and numerous illustrations.....	3.75	MILLER'S GUIDE. By John T. Miller. A paper buyer's hand-book. 91 pages.....	1.00
A HANDBOOK OF PLANT FORM, for students of design. By Ernest A. Clark, Art Master, Derby Technical College. Large 8vo.....	2.60	ESTABLISHING A NEWSPAPER. By O. F. Byxbee. 113 pages, cloth.....	.50
ALPHABETS—A HANDBOOK OF LETTERING By Edward F. Strange. 294 pages, profusely illustrated, cloth.....	1.60	GAINING A CIRCULATION. By Charles M. Krebs 60 pages.....	.50
DRAWING FOR PRINTERS. By Ernest Knaufft 240 pages, over 100 illustrations, cloth.....	2.00	PERFECTION ADVERTISING RECORDS. No. 1, 7 x 10½ inches, for all publications other than dailies; No. 2, 9 x 12 inches, for dailies and all other publications. 200 pages, Russia back and corners, buckram sides. Either style.....	3.50
DRAWING FOR REPRODUCTION. By Charles G. Harper. 162 pages, 47 illustrations, cloth.....	2.35	A CONCISE MANUAL OF PLATEN PRESSWORK. By F. W. Thomas. 32 pages.....	.25
THEORY AND PRACTICE OF DESIGN By Frank G. Jackson. 216 pages, 50 plates, cloth....	2.60	PRACTICAL GUIDE TO EMBOSsing AND DIE STAMPING. By James P. Burbank, New Edition.....	1.50
PARTRIDGE'S REFERENCE HANDBOOK OF ELECTROTYPING AND STEREOTYPING By C. S. Partridge.....	1.50	PRESSWORK. By William J. Kelly. 140 pages, cloth.....	1.50
A MONEY-MAKING SYSTEM FOR THE EMPLOYING PRINTER. By Eben B. Stuart. 100 pages.....	1.00	HANDBOOK OF PHOTOENGRAVING. By N. S. Amstutz. 3d edition.....	3.00
ACTUAL COSTS IN PRINTING. By Isaac H. Blanchard.....	5.00	BIGELOW'S HANDBOOK OF PUNCTUATION By Marshall T. Bigelow. 116 pages, cloth.....	.55
COST OF PRINTING. By F. W. Baltes. 74 pages cloth.....	1.50	CULINARY FRENCH. Compiled by A. A. Munro. 101 pages, paper cover.....	.35
EMPLOYING PRINTERS' PRICE-LIST. By David Ramaley. 1907 edition. Flexible leather...	1.25	ENGLISH COMPOUND WORDS AND PHRASES. By F. Horace Teall. 312 pages, cloth	2.60
FUNDAMENTAL PRINCIPLES OF ASCERTAINING COST OF MANUFACTURING. By J. Cliff Dando.....	10.00	GRAMMAR WITHOUT A MASTER. By William Cobbett, revised and annotated by Alfred Ayres. Cloth	1.10
HINTS FOR YOUNG PRINTERS UNDER EIGHTY. By W. A. Willard. 50 pages, paper....	.50	PEERLESS WEBSTER DICTIONARY. Vest pocket size, full leather, gilt.....	.50
HOW TO MAKE MONEY IN THE PRINTING BUSINESS. By Paul Nathan. 375 pages, cloth	3.20	PUNCTUATION. By F. Horace Teall. 193 pages	1.10

THE H. C. HANSEN TYPE FOUNDRY

BOOKS FOR PRINTERS—Continued

- THE AMERICAN HANDBOOK OF PRINTING.
By Edmund G. Gress. 315 pages, 182 illustrations,
cloth.....\$2.00
- TYPE DESIGNS IN COLORS. By Edmund G.
Gress. Over 100 designs in color, 9 x 12 inches, paper 1.00
- PAY-ROLL TABLES (8 and 9 hour). Show at a
glance amount due per hour or any five minute fraction
thereof. 32 tables in each set of wages from 50 cents
to \$31.00 per week. Per set..... .50

The Inland Printer

An authoritative monthly encyclopedia of
technical literature in the printing and
allied trades. Inspiring and suggestive.
Indispensable in the advertising depart-
ment

\$3.00 PER YEAR IN ADVANCE
30 CENTS PER COPY
For Sale by The H. C. Hansen Type Foundry

The American Printer

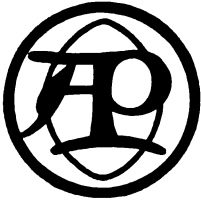

A monthly trade journal for the
printer, publisher, bookbinder, en-
graver and electrotyper. Helpful
and interesting to the proprietor,
journeyman and apprentice.

\$2.00 PER YEAR
IN ADVANCE
20 Cents Per Copy
For Sale by The H. C. Hansen Type
Foundry

THE CROSBY COLOR CHART

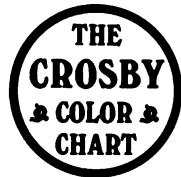

Should be in Every Office

A Chart of the Spectrum Colors, re-
duced with black, intensified with white,
making 50 colors in all, from which by
means of masks, 2, 3, 4 and 5-color com-
binations can be seen at a glance, and the
proper surface proportion of each combina-
tion shown. A great time saver, and an
absolutely correct scientific chart. Full directions on each
chart. Price.....\$3.50

R. R. BURRAGE PADDING GLUE

1-lb.....\$0.30 5-lb. can.....\$1.25
3-lb. can..... .75 10-lb. can..... 2.00

Regular High Grade Book Binders' Glue

The stock used in this book is Sterling Coated. See page 377

NICHOLS' PERFECT ORDER AND RECORD BOOK

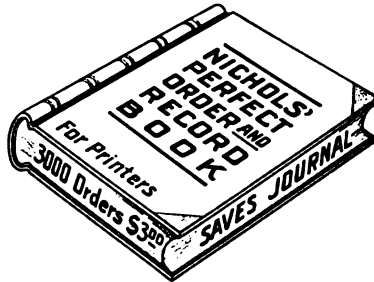

A useful record book
for printers running
offices of moderate
size. It serves both
as an order book and
a journal. By using
this book you can
learn at a glance
whether orders are
complete, what their
cost is, and if they

have been posted. Once entered in this book it is impossible
to omit charging an order. Size, 9 x 12 inches; capacity, 3000
orders.....\$3.00

BATCHELDER'S TIME-SAVING SYSTEM, for
printers, publishers, newspaper and advertising men.
Figured in 8 graded styles of type, leaded and solid,
modern and old style, all sizes, 5 to 18 point, postpaid .50

A Monthly Magazine of the Art of Printing and of the
Allied Arts



\$3.00 PER YEAR IN ADVANCE
30 CENTS PER COPY
For Sale by The H. C. Hansen Type Foundry

THE HANSEN COPY HOLDER

The Hansen Copy Holder is strong and simple in con-
struction and cannot get
out of order. By its use
the copy is kept directly in
front of the compositor
and leaves free access to all
compartments
of the case.

Price \$1.00

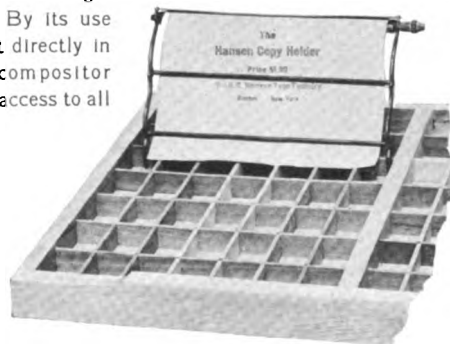

Hansen Copy Holder

THE H. C. HANSEN TYPE FOUNDRY

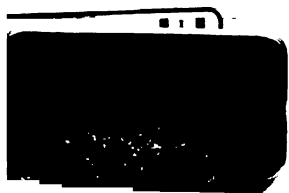

HECKMAN
BINDERY INC. 
MAR 97
Bound in 96

UNIVERSITY OF ILLINOIS-URBANA



3 0112 005628695