



This is a digital copy of a book that was preserved for generations on library shelves before it was carefully scanned by Google as part of a project to make the world's books discoverable online.

It has survived long enough for the copyright to expire and the book to enter the public domain. A public domain book is one that was never subject to copyright or whose legal copyright term has expired. Whether a book is in the public domain may vary country to country. Public domain books are our gateways to the past, representing a wealth of history, culture and knowledge that's often difficult to discover.

Marks, notations and other marginalia present in the original volume will appear in this file - a reminder of this book's long journey from the publisher to a library and finally to you.

### **Usage guidelines**

Google is proud to partner with libraries to digitize public domain materials and make them widely accessible. Public domain books belong to the public and we are merely their custodians. Nevertheless, this work is expensive, so in order to keep providing this resource, we have taken steps to prevent abuse by commercial parties, including placing technical restrictions on automated querying.

We also ask that you:

- + *Make non-commercial use of the files* We designed Google Book Search for use by individuals, and we request that you use these files for personal, non-commercial purposes.
- + *Refrain from automated querying* Do not send automated queries of any sort to Google's system: If you are conducting research on machine translation, optical character recognition or other areas where access to a large amount of text is helpful, please contact us. We encourage the use of public domain materials for these purposes and may be able to help.
- + *Maintain attribution* The Google "watermark" you see on each file is essential for informing people about this project and helping them find additional materials through Google Book Search. Please do not remove it.
- + *Keep it legal* Whatever your use, remember that you are responsible for ensuring that what you are doing is legal. Do not assume that just because we believe a book is in the public domain for users in the United States, that the work is also in the public domain for users in other countries. Whether a book is still in copyright varies from country to country, and we can't offer guidance on whether any specific use of any specific book is allowed. Please do not assume that a book's appearance in Google Book Search means it can be used in any manner anywhere in the world. Copyright infringement liability can be quite severe.

### **About Google Book Search**

Google's mission is to organize the world's information and to make it universally accessible and useful. Google Book Search helps readers discover the world's books while helping authors and publishers reach new audiences. You can search through the full text of this book on the web at <http://books.google.com/>

3 3433 00635088 2



11/11







not in L.V. -  
7/22/31/B.W.

# THE MONOTYPE PONY SPECIMEN BOOK

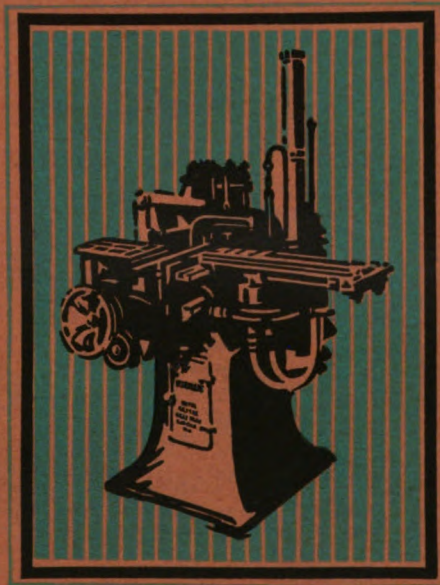

LANSTON MONOTYPE MACHINE COMPANY



THE NEW YORK PUBLIC LIBRARY  
ASTOR, LENOX AND TILDEN FOUNDATIONS

\* \* \*

FROM THE LIBRARY OF  
GEORGE H. SARGENT  
LONG "THE BIBLIOGRAPHER" OF  
THE BOSTON TRANSCRIPT  
1931

“  
NG  
artistic  
ys and  
equal  
blacks in a page apply with equal  
force to the individual words. Spacing  
between the letters of a word lessens its strength  
of tone—the wider the spacing, the “grayer” the  
word. Printing ink makers are ever striving for a  
“dense” black. Their efforts are fruitless on a type  
page if the page is “grayed” by the dissemination  
of white space between the letters.

The concentration of solids and white space  
produces contrast of color—enhances beauty and  
invests with appeal. There is but one compos-  
ing machine whose product has strong contrast  
of color—the Monotype.



LANSTON MONOTYPE MACHINE CO.  
PHILADELPHIA

THE MONOTYPE PONY SPECIMEN BOOK OF TYPE FACES

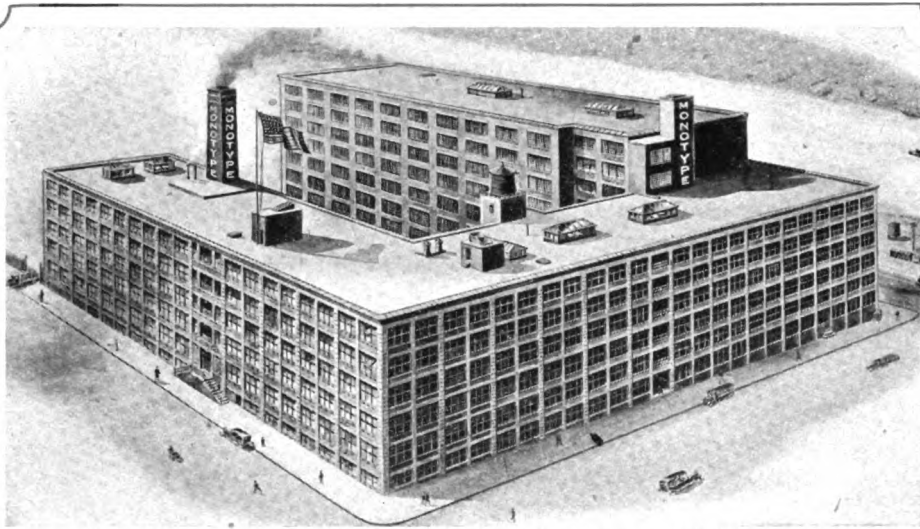

WHERE MONOTYPES ARE BUILT AND MONOTYPE MATRICES ARE DESIGNED AND MADE

**T**HIS modern concrete building, built by the Monotype Company, contains 200,000 square feet of floor space, devoted exclusively to the manufacture of Monotype machines and Monotype accessories. It is equipped throughout with modern machinery, including many special machines designed and built by the Monotype Company. It is a factory with a reputation for quality product and accurate work unsurpassed by any manufacturing plant.

Nothing succeeds like success: The success of the Monotype Company is due to the merit of the Monotype machine and enthusiastic support of Monotype users. Half the machines we sell go to our old customers on repeat orders, and a very large proportion of our new customers come to us on the recommendation of Monotype users.

THIS BOOK DOES NOT CONTAIN ALL THE MONOTYPE FACES : FOR AD-  
DITIONAL TYPE FACES, FIGURES, FRACTIONS, SIGNS, ETC., CONSULT  
THE COMPLETE LOOSE-LEAF SPECIMEN BOOK OF MONOTYPE FACES

THE  
**MONOTYPE**

PONY SPECIMEN BOOK  
OF TYPE FACES  
RULES, ORNAMENTS  
&  
BORDERS

1921



LANSTON  
MONOTYPE MACHINE COMPANY  
PHILADELPHIA

THE NEW YORK  
PUBLIC LIBRARY  
**569668 A**  
ASTOR, LENOX  
TILDEN FOUNDATION  
R 1931 L

COPYRIGHT 1921  
BY  
LANSTON MONOTYPE  
MACHINE COMPANY

TRADE MARK  
**MONOTYPE**  
Reg. U. S. Pat. Off.

MONOTYPE  
MACHINE COMPANY

# MONOTYPE MATRICES

*The Matrix is the secret of the Monotype's Success; the more you appreciate the almost limitless possibilities of Monotype Matrices, the greater will be Your return from Your money invested in Monotypes*

*Two letters are never carried on the same Matrix in the Monotype System, and from this basic principle result both typographic beauty and commercial utility.*

The individual Matrix for each letter means that one alphabet imposes no limitations upon another; thus, the designer of Monotype faces need never strain his ingenuity to make a Roman and an Italic Cap I look "near-well" on the same width body.

The individual Matrix for each letter means that there is no limit, practically speaking, to the combinations of Monotype faces.

*Each character a separate Unit, these Matrix Units combined in the Matrix Case to suit the requirements of the job, not the limitations*

*of a machine. You buy the Matrices you need and combine them with the Matrix Units you have.*

Don't waste your money. Don't let others spend your money for Matrices without a thorough understanding of the Monotype Matrix System which is briefly explained on pages viii and ix, and more completely in the Monotype Specimen Book of Faces.

Beginning on page xv there is an index of Monotype type faces shown in this book, giving the series number and the number of the page upon which a printed specimen of the type face will be found. For a complete list see the Monotype loose leaf specimen book, which gives in detail all necessary information.

*"It Helps You Grow and Grows with You"*

# THE MONOTYPE KEYBOARD AND



## *The Keyboard*

which handles with equal facility all kinds of copy from the plainest to the most intricate, setting it in any measure up to 90 ems. The universal arrangement of the keys makes it easy to operate, and its speed is so great that no operator can possibly be fast enough to stall it.

## *Composing Machine*

This Machine produces all kinds of composition in any size of type from 4-point to 18-point in any measure up to 84 picas.

## *Type-&-Rule Caster*

casts type in all sizes from 4-point to 36-point: Body Type, Display Type, Borders, Rules, Leads, Slugs, Spaces, and Quads.

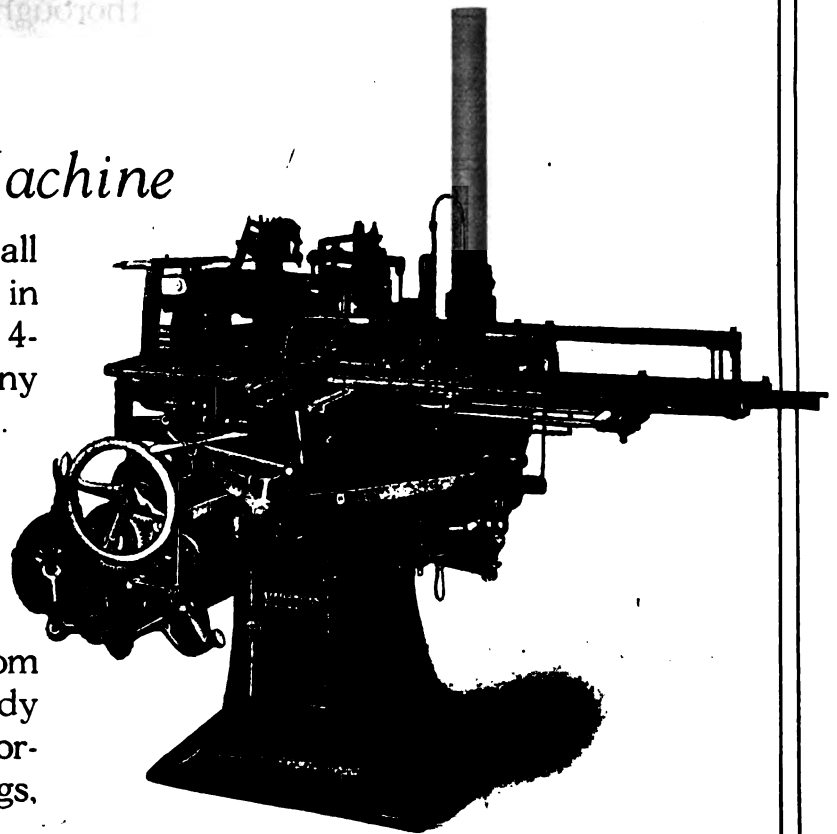

# COMPOSING MACHINES

## *The Matrix Case*

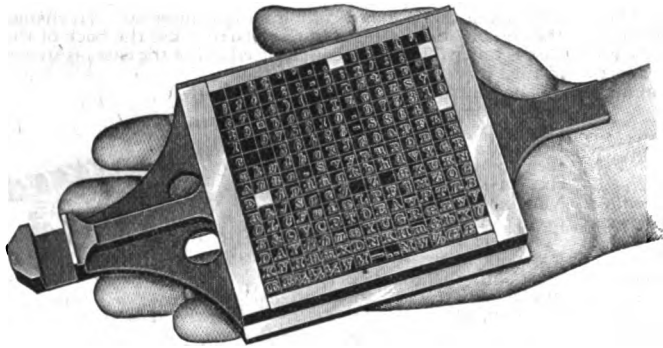

The Matrix Case, with its 225 individual matrices, is practically the heart of the Monotype, and, like the human heart, is vital to the successful use of the machine, though so small that it may be held in the hollow of one's hand.

The arrangement of the separate matrices in the Matrix Case is varied according to the character of the type face it contains: thus the machine is adjusted to the job and it is not necessary to change the job to suit the machine.

## *The Keyboard Arrangement*

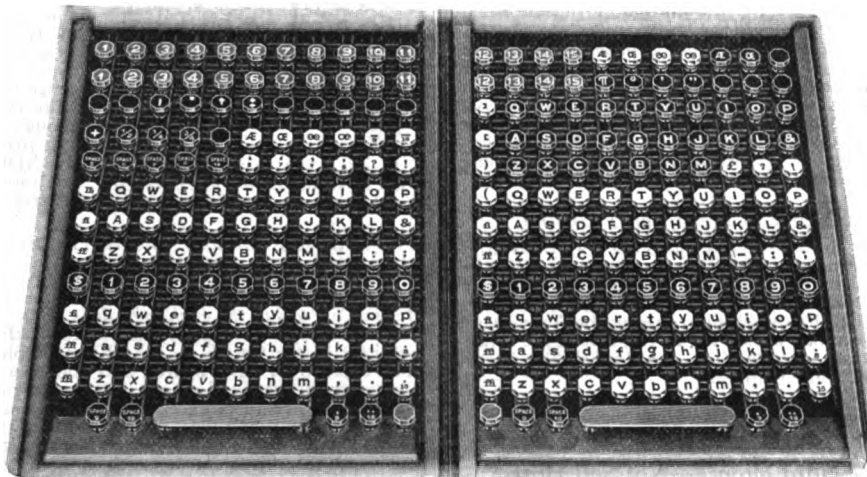

As will be seen by the engraving herewith, is arranged according to the universal typewriter layout, which has been proved by years of experiment and practical use to be the fastest arrangement possible, as well as the easiest for the operator.

The Monotype Keyboard is not changed when the Matrix Case arrangement is altered, but is adjusted by an intermediate part known as the keybar. Thus the speed of the operator is not reduced by an unfamiliar arrangement of the keys. This makes it possible for Monotype operators to acquire a very high speed by using the touch system.



# THE FLEXIBLE MATRIX SYSTEM

## The money-saving and the money-making advantages of our Unit Matrix System are here made clear by Specimens and Pictures

Two letters are never carried on the same Matrix—a Matrix for each character, each Matrix a unit, these units combined in the Matrix Case as required; one alphabet imposes no limitations upon another, and the ingenuity of the designer of Monotype faces is never strained to make a Roman and an Italic cap (I I) on the same width body.

### One Alphabet Imposes no Limitations upon Another

To appreciate the complete freedom from mechanical limitations of Monotype faces examine the two faces here shown. Note how much more extended the 159J is than the 25J—

The best kind of originality is that which comes after a sound apprenticeship; that which shall prove to be the blending of a firm conception of all useful precedent and the progressive tendencies of an able mind. For, let a man be as able and original as he may, he cannot afford to discard knowledge of what has gone before  
Six-point No. 25J Arrangement C1

The best kind of originality is that which comes after a sound apprenticeship; that which shall prove to be the blending of a firm conception of all useful precedent and the progressive tendencies of an able mind. For, let a man be as able and original as he may, he cannot afford to discard knowledge of what has gone before  
Six-point No. 159J Arrangement C2

FIGURE 1—Two six-point faces, both seven-set

yet either this extended face or the condensed face may be carried in the Matrix Case with the same Roman face and be composed with it. Thus, neither the Roman, nor the Boldface used with it, imposes any limitations upon each other.

### Complete Flexibility in Making Combinations of Faces

Fifteen different Boldfaces combined with the same Roman face are shown on page 17. In setting all these specimens the same Roman Matrices were used; one Boldface was taken out of the Matrix Case and the Matrices for the next inserted without touching the Roman Matrices: For each new combination, the Monotype user does not have to "re-buy" his Roman Matrices—he buys what he wants when he wants it—combining the new units required with the old units he has.

### Monotype Matrices Help Sell Printing

But great as are the artistic advantages of our unit Matrix system, these seem almost insignificant compared with the commercial advantages: because the wise Monotype user wastes no time, creates no dissatisfaction, arguing with his customer about the "inadvisability of using the Roman and Boldface" the customer wants, for in the Monotype office, practically speaking, any Boldface may be combined with any Roman of the same point-size.

*"The ability to give your customer what he wants is worth a lot more than the time you save by not having to talk him into being half-satisfied with what you can give him"*

### Matrices of Hard Bronze—Not Soft Brass

The Matrices for composition, made of hard bronze (not brass), are two-tenths of an inch square and one-half inch high. In the lower end (casting position) is driven the character, clean cut and sharp, with deep counters; in the upper end is bored the cone-hole in which the taper centering pin seats, accurately positioning the Matrix and holding it on the Mold while the type is cast.



FIGURE 2  
The Cellular Matrix

### The Matrix Case Complete with Matrices Weighs only Thirty Ounces

Fig. 11, page 21, shows the size of the Matrix Case, which weighs, with the 225 Matrices it contains, only thirty ounces. To change from one combination of faces to another the case complete is taken out of the Casting Machine, and the case

containing the required combination is inserted. To change the combination of faces in the Matrix Case the back of the case is taken off and the combs lifted out of the case, as shown in Fig. 3.

The Matrices are carried in the Matrix Case on combs, fifteen Matrices on a comb and fifteen combs in the Matrix Case. Thus, each Matrix is held in true position, in its own "cell," it cannot twist, it cannot move, to wear itself and the Matrices next it—it is "put" and it "stays put."



FIGURE 3—The comb and Matrices it carries. (Half Size)

### The Alignment of Monotype Faces is Right and it Stays Right

The centering pin seats in the Matrix after the case has moved and brought the required Matrix over the Mold. The Matrix cannot move or rock, for the taper end of the pin fits tight in the cone-hole of the Matrix, so that they are practically one piece. The pin is guided close to its lower end by a bushing (not shown in the picture), and every character must be perfectly positioned on its body—the alignment cannot vary. In the picture the Matrix Case is broken away to show how the steel combs and bronze Matrices interlock to give the wear-resisting qualities of a slab of reinforced concrete, and yet each Matrix has "play" enough for the centering pin to position the Matrix accurately without moving the Matrix Case.

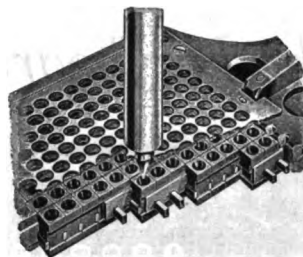

FIGURE 4—The centering pin about to seat in the Matrix from which the next type is to be cast. (Half Size)

### Matrices for 225 Characters and Spaces in each Matrix Case

Two hundred and twenty-five Matrices are combined in the Matrix Case to suit the work to be done: The Monotype user does not scheme to change the job to fit the machine—he makes the Matrix Case fit the job. For example, Roman caps, small caps, lower case, figures, and points, with Italic caps, lower case, figures, and points, may be carried in the same Matrix Case; or a Boldface, extended or condensed, may be substituted for the Italic; or, by omitting the diphthongs, six alphabets may be used together, Roman, Italic, and Boldface—with this arrangement words cannot be set in the Italic caps.

### All Hand Work of Composition is Done by the Compositor—Not the Machine Operator

With the Monotype all hand work is done by a compositor, not by a machine operator, for a composing machine is too expensive for its operator to use as a "stick" to set Matrices by hand from a "pi-box"—the Monotype is the machine that keeps itself—not its operator—busy.

Inrequently used characters not carried in the Matrix Case are not omitted from the job—when one is required the operator strikes any character of the same width, and when the matter is corrected by hand at the case, this is exchanged for the character desired without affecting the justification.

Special figures of six-point may be inserted in the Matrix just as the figures here shown were cast in hand work of any kind (see Display Figure Matrices, page 23).

**\$1.55**



# MONOTYPE UNITS

## Unit A: The Type & Rule Caster

This is the cornerstone of the Monotype System of Composing-Room Efficiency. *It is the simplest and fastest machine ever made for printers to cast their own type, borders, space material, rules, leads, and slugs.*

This unit includes the Speed Regulating Attachment (see Unit H, page 37), which gives nineteen different speeds, so that type may be cast at the maximum speed at which it can be cooled. Complete cooling is provided for by ample water circulation, not only through the base of the machine

on which the Mold units rest, but also through the Molds themselves.

The Type & Rule Caster will average, day after day, 125 pounds of type in eight hours, and this average of over fifteen pounds an hour includes the usual time required for changing the machine for different point-sizes. The output varies with the type-size, from ten pounds an hour on six-point to twenty pounds on thirty-six-point. Two-point rules are cast and automatically cut to length at a speed of 300 feet an hour.

**Of the many exclusive advantages of this machine, note especially these:**

*It is the only machine that casts both type and rules, leads, and slugs, automatically cut to the length desired. It is the simplest casting machine ever built; its Molds are self-contained units. Every Mold goes in place complete, ready for casting; the Mold is not*

*"built up" on the machine. The great accuracy, vital in type-casting, is built into the Mold; therefore, wear of the machine, or careless adjustment, cannot affect the accuracy of the type this machine casts.*

*It is the only type caster that has ample water circulation, so that, when casting at very high speed, the blocks of the Mold, against which the type is cast, may be kept at the proper temperature.*

*Mechanically, the design and workmanship are the result of our experience in building more than 5000 type casters.*

*While the machine is built to gages, so that all parts are interchangeable, ample adjustments are provided to take up wear; the cams run in a bath of oil and will last a lifetime. Many of these machines have been run continuously, night and day, for ten years, and are now doing as good work, and as much work, as machines just out of our factory.*

FIGURE 33—The Type & Rule Caster

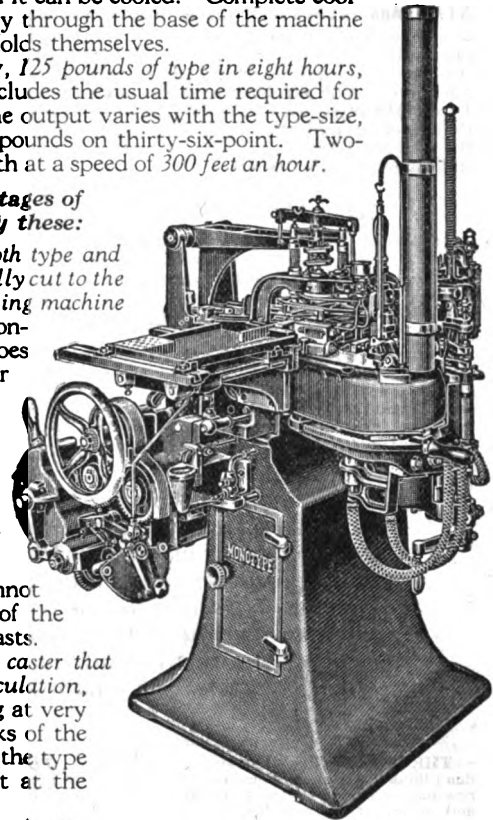

Monotype  
Monotype  
Monotype  
Monotype  
Monotype  
Monotype  
Monotype  
Monotype  
Monotype  
Monotype  
Monotype  
Monotype

### Units used with Type & Rule Caster

**Molds for Type Casting:** This machine uses Molds (Units G, G1, G2, and G3, page 36) for casting type, borders, high and low quads and spaces in all sizes from five- to thirty-six-point.

**Matrixes for Type Casting:** See Unit E, pages 34 and 35.

**Matrix Holders:** Units F2 and F3, page 35.

**Molds for Rule and Lead Casting:** These Molds (Unit G4, page 36) cast rules and leads, both high and low, in continuous strips of any size selected from two- to twelve-point inclusive.

**Matrixes for Rule Casting:** Unit E, page 35.

**Molds for Column Rule:** (Unit G6, page 36.) These Molds cast column rules, in addition to the regular rules and low, intermediate and high slugs.

**Tie-Up Slug Molds:** (Unit G5, page 36.) A modification of the Lead and Rule Mold; it furnishes high and low slugs and foundry guards with a groove in the side for the string, to save untyming pages; see Fig. 6, page 9.

**Automatic Cutter:** This automatic attachment (Unit J, page 37) accurately cuts the product of the Lead and Rule Molds to any required length from six picas to twenty-five inches, and piles on galleys the pieces it cuts.

**Motor:** See Unit N, page 38.

**Details:** This machine is never sold without the Display Type Attachment (Unit H, page 37), and while the Lead and Rule Mold Attachment (Unit I, page 37) need not be furnished, none of our customers omit this. Requires floor space, including necessary clearances, of 7' 2" by 6' 9" Net weight, without any additional units, 1375 pounds. Gross weight boxed for shipment, including box of small parts removed for shipment, 1975 pounds. Box sizes: 3' 7 1/2" by 4' 8 1/2" by 4", and 2' 3 1/2" by 1' 5" by 1' 8". Should be driven by Motor (Unit N, page 38) to insure uniform speed; may be driven from shafting, in which case pulley on shaft must have three-inch straight face, to provide for shifting belt from loose to fast pulley on machine to start and stop; machine pulley, fourteen-inch diameter, must make 140 revolutions per minute. Machine must be connected to water supply and drain to provide for cooling system. Metal melted by gas, gasoline burners, electric melting pot (Unit Z, page 38) furnished if ordered. Machine will use any metal used on any type- or line-casting machine.



FIGURE 34—Some Monotype rules. This picture shows one minute's product—twenty two-point rules (18 picas long) cut as cast, as clean and as even as a deck of cards. Twenty rules a minute—count 'em

**And it is the only type caster that can be made a composing machine**

The Type & Rule Caster may be converted into the Monotype Composing Machine for casting type in lines set up ready to print from (Unit B, page 31), without any loss in efficiency as a Type & Rule Caster. The cost of applying the additional units to the Type & Rule Caster is the difference in the prices of the two machines. Thus, when you buy our Type & Rule Caster you have paid more than half the cost of your next composing machine.

## Unit B: The Composing Machine

This is Unit A, page 30, the Type&Rule Caster, equipped with the units for automatic control by the paper ribbon which the compositor perforates at the Keyboard (Unit C, page 32). Thus, instead of casting a supply of one letter, from a Matrix placed in casting position by the operator, *this machine delivers, on ordinary galleys, a product exactly the same as*

*The paper ribbon feeds* (Unit F, page 35) to bring the At the same time the machine proper width. In the same way that the finished lines are just whether the line be straight

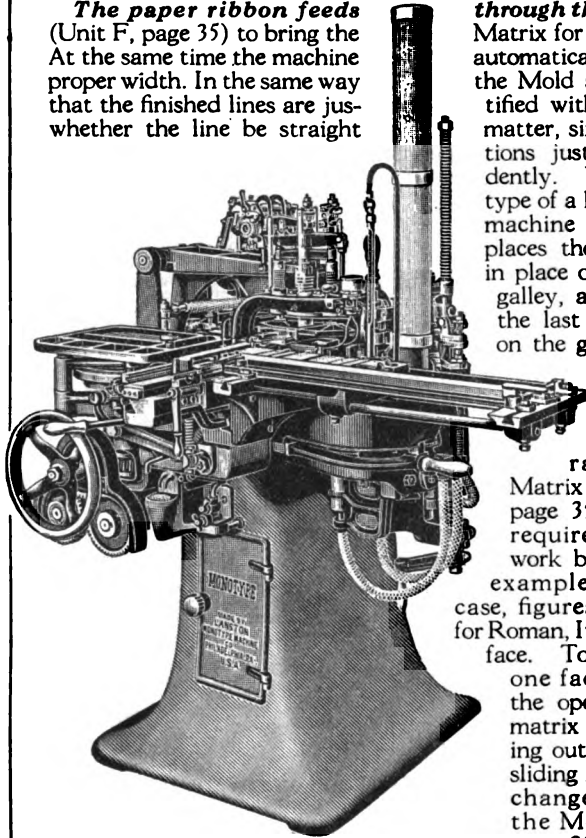

FIGURE 35—The Composing Machine

of the required size is put on. The measure is changed exactly the same as a compositor sets his stick.

*All corrections and alterations are made by hand at the case;* therefore, this machine is never changed in measure, point-size, or face except before starting a new job that differs from the job just finished. Compared to any other composing and casting machines, the non-productive time of changing the Monotype is negligible.

*"The Always Busy Machine"* is the name by which Monotype users call Unit B, for it never stands idle: when there is no composition, it is used as the Type&Rule Caster, making the material used by hand compositors—type, spaces, borders, rules, leads, and slugs.

Since printers operating more than one Monotype need but one machine equipped for casting rules and the larger sizes of type, Unit B is built to produce lines of any measure up to forty-two picas (60 picas with Unit K, page 38, added), and to use any Molds (Unit G, page 36) from five- to twelve-point inclusive, as well as Molds for casting twelve-point faces on thirteen- or fourteen-point bodies.

The capacity of Unit B is increased by adding additional units, as described under "Units to Increase the Capacity . . . as a Composing Machine." Thus, its range as a composing machine may be increased, or it may be equipped to do all the work of the Type&Rule Caster (Unit A, page 30).

*brand-new foundry type set by hand.* **through the machine** and it automatically positions the Matrix Case Matrix for the required character over the Mold into casting position. automatically adjusts the Mold to make the body size of the letter the the Mold sets itself for the width of the spaces between words, so tified with mathematical accuracy. This justification is perfect, matter, sixty picas wide, or tabular matter made up of several sections justified independently. When the last type of a line is cast, the machine automatically places the finished line in place on an ordinary galley, and as soon as the last line is placed on the galley, the machine stops itself.

The Matrices are arranged in the Matrix Case (Unit F, page 35) to suit the requirements of the work being cast; for example, caps, lower case, figures, and points for Roman, Italic, and Bold-face. To change from one face to another the operator changes matrix cases by sliding out one Case and sliding in another. To change point-sizes, the Mold (Unit G, page 36) is taken off and a new Mold unit



FIGURE 36—The product of the Composing Machine—brand-new type cast in perfectly justified lines

### Units used with Composing Machine

**Molds for Composing and Casting:** (Units G and G1, page 36) These Molds make type set in justified lines with high or low quads and spaces, as well as casting for the hand compositors type, borders, and space material.

**Matrices:** (Unit E, page 34.) For casting type either in automatically justified lines or to be set by hand from the case.

**Matrix Case:** See Unit F, page 35.

**Wedge:** (Unit M, page 38.) This determines the width of the characters cast, just as the Mold determines their point-size.

**Motor:** See Unit N, page 38.

### Units to Increase the Capacity of Unit B as a Composing Machine

Unit B, the Composing Machine, may be equipped with any, or all, of the following units, which increase the usefulness of Unit B, but never reduce its efficiency or limit its output on any work.

**Wide-Measure Attachment:** (Unit K, page 38.) Enables the Composing Machine to deliver lines of any length up to sixty picas, instead of a maximum length of forty-two picas.

**Eighteen-Point Attachment:** Equipped with this (Unit L, page 38) the Composing Machine will automatically compose fourteen- and eighteen-point matter, exactly the same as the regular machine casts and sets type twelve-point and smaller: Note: Since these larger sizes must be cast at slower speed, a machine equipped with this attachment must also have the Display Type Attachment, see next paragraph.

**Display Type Attachment:** (Unit H, page 37.) Equipped with this the Composing Machine may also be used for casting type and space material for use on hand composition, in all sizes from fourteen- to thirty-six-point, exactly the same as Unit A, the Type&Rule Caster, using the Molds for type casting.

### Units to Increase the Capacity of Unit B as a Type&Rule Caster

Same as units used with the Type&Rule Caster (page 30), when the Composing Machine is equipped with Display Type Attachment.

**Details:** Requires floor space, including necessary clearances, 7' 2" by 6' 9". Net weight, without any additional units, 1325 pounds. Gross weight, boxed for shipment, 1960 pounds. Box size, 3' 7½" by 4' 8½" by 4'. Should be driven by Motor (Unit N, page 38) to insure uniform speed; may be driven by shafting, in which case pulley on shaft must have three-inch straight face, to provide for shifting belt from loose to fast pulley on machine to start and stop; machine pulley, fourteen-inch diameter, must make 140 revolutions per minute. Machine must be connected to water supply and drain to provide for cooling system; also to air compressor, which we furnish, to supply air for automatic control. Metal melted by gas, gasoline burner or Electric Melting Pot (Unit Z, page 38) furnished if ordered. Machine will use any metal for making type for the cases, used in any type- or line-casting machine; for casting type in automatically justified lines Monotype metal must be used: linotype metal is too soft and lacks tin necessary for casting at high speed.

# MONOTYPE UNITS

## Unit C: The Style D Keyboard

*This is the simplest, fastest, most flexible composing machine ever devised. While operating the Monotype Keyboard the compositor gives no thought to mechanisms or problems of casting metal. He hits the keys—that's all; his work is recorded on the paper ribbon which controls the automatic Composing Machine (Unit B, page 31).*

*The Keyboard has the universal typewriter key arrangement (page 21). Would you buy a typewriter without the universal keyboard? But the stenographer uses only two alphabets, caps and lower case; the Keyboard operator must use six alphabets.*

*For different measures the Keyboard is adjusted the same as the margin stop on a typewriter, as quickly as a compositor can set his stick.*

*For different faces the operator lifts off one Justifying Scale (Unit U, page 40), and puts on another if the new face to be set is of different width.*

*For different point-sizes there is no change of any kind. In fact, the operator can finish his copy, read from the line counter the number of lines it makes, and then determine whether to cast the matter solid, on its own body, or lead it by casting it on a larger size body to make it fill the required space. This unique advantage in making the copy fit the space is possible only with the Monotype.*

*For changes in combinations of faces for different Matrix Case arrangements; for example, to substitute Boldface for Italic, the operator lifts off the Keybank (Unit S, page 40) and changes the Keybars (Unit R, page 40).*

*For very radical changes it is sometimes desirable to substitute one Keybank for another, but for any ordinary work, changes in key arrangements are made by capping the keys (Unit V, page 40).*

*To change the counting mechanism, for example, to provide for two- or three-line figures in advertising matter, the Stopbars (Unit T, page 40) are changed.*

*Any or all changes possible at the Keyboard are made quicker than a compositor can put up a new pair of cases and set his stick. Furthermore, since all corrections or alterations in matter previously set are made by a hand compositor at the case, after the matter is cast, the Keyboard is never changed except before starting on a new job that differs from*

*the one just finished. Compared to composing machines which are changed to set alterations or corrections, there is no lost time on changing the Monotype.*

*When the operator strikes a key the paper is perforated and the width of the character is automatically measured and added to the sum of the characters previously struck. Therefore, the Monotype operator can tell at a glance exactly how much of a line, or a section of a line, has been set and how much more must be set. Thus, the Keyboard is more than a composing machine, and with it the operator can set matter that cannot be set commercially on any other composing machine and which would indeed puzzle any hand compositor. For example, examine the specimens of double and triple justified matter on this page (Fig. 38).*

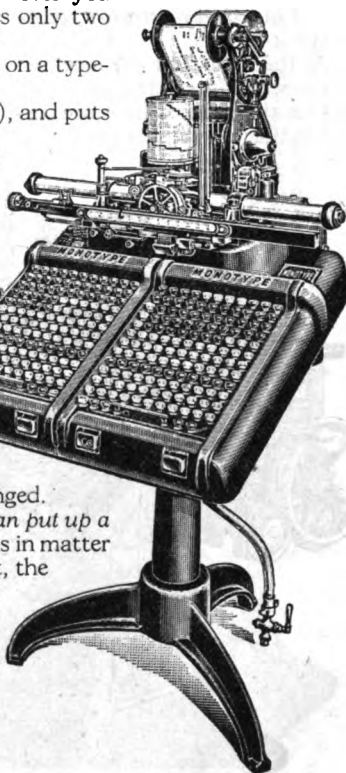

FIGURE 37—The Style D Keyboard

### Units used with the Keyboard

**Justifying Scales:** (Unit U, page 40.) Used to vary the width, or set-size, of faces.

**Keybars:** (Unit R, page 40.) These are changed to vary the coupling of the keys to the punches for different Matrix Case arrangements.

**Stopbars:** (Unit T, page 40.) For altering the counting mechanism for use with special Matrix Case arrangements, for example, those containing two- or three-line figures.

**Keybanks:** (Unit S, page 40.) For changing the key arrangements. Note: extra Keybanks are very rarely required; any ordinary changes are made with Keybutton Clips.

**Keybutton Clips:** (Unit V, page 40.) For special characters not on the Keyboard these Clips are placed over the buttons for characters not needed.

**Spools:** See Unit W, page 40.

### Units used to Increase the Capacity of the Keyboard

**Electric Light:** (Unit P, page 39.) This consists of a magnifying glass in front of the Justifying Scale and a small light that lights up the Scale at the end of the line, also a suitable copy light; designed especially to eliminate the fatigue of eye strain.

**Automatic Repeater:** (Unit O, page 39.) A little air engine built into the Keyboard that operates any characters that repeat, as quads, leaders, etc., at five times the speed of the fastest operator.

**Ninety-Em Scale:** (Unit Q, page 39.) For very wide measure work this avoids the use of double justification, increasing the measure from sixty-five to ninety ems.

**Details:** Requires floor space of 4' 11" by 4'. Net weight of Keyboard complete, as described above, without additional units to increase capacity, 435 pounds. Gross weight, including Keybanks and Keybars, boxed separately and base standard crated, 820 pounds. Box sizes, 2' 9 1/2" by 2' 9 1/2" by 3', 1' 10 1/2" by 1' 3" by 2' 2", 2' 4" by 2' 4 1/2" by 2' 8". Operated by compressed air supplied by compressor which we furnish.

*All that the compositor can do with his board: he can instantly justify a line of measure into several separate columns (the sum of the measures of these narrower columns equaling the full measure) and make a separate and distinct justification for each column. All these columns and then combined, but at the end of each section before beginning to set the next section of the same line. The justification is absolutely*

*any measure, or he can divide the full (the sum of the measures of these narrower columns equaling the full measure) and make a separate and distinct lines were composed and cast the full measure, just as this specimen reads. They were not set in separate columns and then combined, but at the end of each section the operator justified that section before beginning to set the next section of the same line. The justification is absolutely accurate for each column and full measure.*

FIGURE 38—Double and triple justified matter set with perfect accuracy and almost as easily as straight matter on the Monotype

Remember that the Monotype operator wastes no time in justifying type or Matrices; that is, pieces of metal that are more or less worn by use. His "calculating machine" tells him, without any mental effort on his part, the size the different spaces must be, and then he strikes the keys that cause his automatic type foundry to cast these spaces the exact size required to perfectly justify the line.

With each Keyboard we furnish a keyboard cover, one set of Stopbars, two paper Spools, and the following equipment as selected: one Justifying Scale, one each right and left standard Keybanks and Keybars. The Keyboard will set any kind of matter, plain or tabular, in any size of type or measure within the capacity of the Composing Machine (Unit B, page 31).

# MONOTYPE UNITS

## Unit D: The Duplex Keyboard

This is the ultimate in composing-machine flexibility; the apex of our unit system of machine construction. It would be scarcely possible to imagine a composing machine more free from mechanical limitations; indeed, the Duplex Keyboard goes so far beyond anything hitherto considered possible that it has given to the printing world an absolutely new mechanical process—*Duplicating*:

*This Keyboard composes simultaneously the same matter in two different faces, point-sizes, and measures; the same keystrokes that produce the ribbon for magazine columns in eight-point, for example, also produce the ribbon for the same matter in ten-point for book pages.*

*The Duplex Keyboard is not a specialty machine, with a limited field: it is not a mechanical monstrosity; these Keyboards are used in every kind of printing office for every kind of work; they are as simple, as free from complications, as the single Keyboard (Unit C, page 32), because in our unit system of machine construction the application of additional units never handicaps the machine, never makes it more complicated or less efficient on any kind of work.*

*The Duplex Keyboard is identical with the Style D Keyboard from the floor up to, and including, the keys; it has, however, two units for perforating paper ribbons and two units for measuring and counting the width of the characters as they are struck. In short, except for the Switch (see below), the Duplex Keyboard is exactly the same as two single Keyboards, placed so closely side by side that the operator could work with perfect ease on either Keyboard without shifting his copy.*

*The Switch, Fig. 40 (half size), is the key to the simplicity of the Duplex Keyboard; when this little lever is turned to the right, as shown in the picture, the right paper-perforating and character-counting mechanisms are locked out and do not exist, as far as the operator is concerned, for they cannot hamper or hinder his work. Turn the Switch to the left; the keys operate the right punching and counting mechanisms while the left side is locked out and inoperative.*

*Turn the Switch to central position and the keys operate both paper-perforating and character-counting mechanisms, for duplicating or for a dozen different short cuts to profits in setting tabular or intricate matter.*

*"Turn the Switch—that's all." With one handling of copy the operator may set text and notes in two different sizes of type, or heads for a catalog may be set at the same time as text. It costs money to stop and start work, to take a job up and put it down unfinished, and the Duplex Keyboard saves this expense. The difference between the single and the double Keyboard is the difference between a single- and a double-track railway—"Turn the Switch—that's all."*

*The same keys that produced the seven-point matter above, now produce this six-point, exactly as if the operator had moved with his copy to another Keyboard, as quickly as he could strike a key. The six-point finished, to go on with the seven-point—"Turn the Switch—that's all."*

*To change from one job to another with the minimum of confusion and expense, "Turn the Switch—that's all" to side-track the interrupted job while the rush job goes by it on the other paper tower.*

*The rush job is set in its own face and measure without disturbing the regular job, side-tracked to let the special go by, and then, the rush job finished, to go on with the regular job—"Turn the Switch—that's all."*

*For extra wide measure work, one-half the line is set on the left ribbon and the other half on the right; when the matter is cast, the two sections are put together. Thus, even without the Wide-Measure Attachment (Unit K, page 38), the Duplex Keyboard makes the maximum measure eighty-four instead of forty-two picas. "Turn the Switch—that's all."*

*For "estimating" this Keyboard is unique: Your customer says, "Use the biggest type you can."—Question: If you use twelve-point, will the matter go in? Ought you to use ten-point? Set the job in both sizes on the Duplex Keyboard; determine from the line counters the number of lines in each size and cast from the ribbon that best suits the job. The Duplex Keyboard will not give back the money you have lost resetting to make the type fit the space, but it will insure you against similar future losses. "Turn the Switch—that's all."*

*For Duplicating the Duplex Keyboard gives a double product, two letters for each keystroke, absolutely independent in faces, point-sizes, measures, and spacing; it does not enlarge nor reduce; it composes the same matter in two different and entirely distinct forms at the same time. An article may be set for a magazine in eight-point closely spaced and, at the same time, in eleven-point widely spaced for a book: both for one keyboarding cost.*

*A new process of composition is made possible by the Duplex Keyboard; it will simultaneously compose two different styles of type in any different measures and faces—the same keystrokes that produced this paragraph made the paragraph beside it.*

*A new process of composition is made possible by the Duplex Keyboard; it will simultaneously compose two different styles of type in any different measures and faces—the same keystrokes that produced this paragraph made the paragraph beside it.*

*With each Keyboard we furnish a keyboard cover, two sets of Stopbars, four paper Spools, and the following equipment as selected: two Justifying Scales, one each right and left standard Keybanks and Keybars. The Keyboard will set any kind of matter, plain or tabular, in any size of type or measure within the capacity of the Composing Machine (Unit B, page 31).*

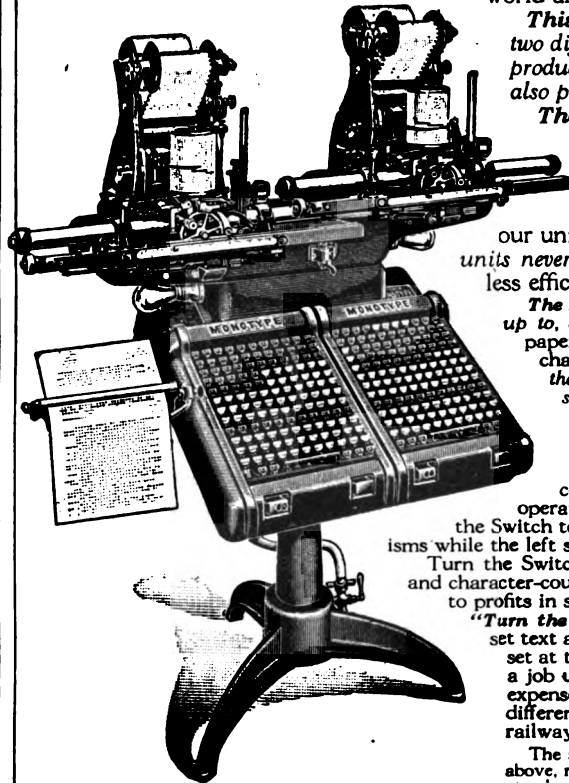

FIGURE 39—The Duplex Keyboard

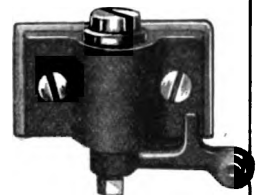

FIGURE 40  
THE SWITCH

"Turn the Switch—that's all"

**Units used with the Keyboard**  
Same as for Style D Keyboard (page 32).

**Units used to Increase the Capacity of the Keyboard**

Same as for the Style D Keyboard (page 32), except that the Ninety-Ern Scale is not furnished, since the Duplex Keyboard provides for handling very wide measure work without this unit.

**Details:** Requires floor space 5' 4" by 5' 8 1/2". Net weight of Keyboard, as described above, without additional units to increase capacity, 585 pounds. Gross weight, including Keybanks and Keybars, boxed separately and base standard crated, 1145 pounds. Box sizes, 4' 6 1/2" by 2' 9 1/2" by 3' 4 1/2", 1' 10 1/2" by 1' 3" by 2' 2", 2' 4" by 2' 4 1/2" by 2' 8". Operated by compressed air supplied by compressor which we furnish.

## Monotype Faces

This Specimen Book shows Monotype Faces of two kinds: (a) the faces from 4-point to 12-point, inclusive, for casting type on the galley, either in justified lines or to be set from the case by hand, which are made in cellular matrices; and (b) the faces from 14-point to 36-point, inclusive, for casting type for the cases, which are made in electro display matrices; a few faces smaller than 14-point are made in electro display matrices because their extended faces are more than 12½ set, which is the limit in a cellular matrix.

This thin paper book has been issued to meet a demand for specimens of Monotype faces by publishers, advertisers, buyers of printing, and prospective Monotype users. The paper on which it is printed is made as light as is consistent with strength and opacity in order to aid in the conservation of paper at a time when the demand is in excess of the ability of the mills to create a supply. Monotype customers receive specimens of all faces as they are finished, inserting them in the loose-leaf book in their proper order.

Monotype faces are designated by numbers, not names. The similar faces are grouped, regardless of their serial numbers, so that they will come within the different type families commonly understood by printers; for example, all the Gothics are together, all modifications of our No. 64 family, Italics, Ionics, Outlines, and Typewriter.

|  | FONTS | PAGES   |
|--|-------|---------|
| Modern Faces (Roman and Italic) . . . . .    | 165   | 1-42    |
| Old Style Faces (Roman and Italic) . . . . . | 250   | 43-93   |
| The No. 64 Family . . . . .                  | 77    | 94-122  |
| Antiques . . . . .                           | 192   | 123-195 |
| Titles . . . . .                             | 162   | 196-231 |
| Gothics . . . . .                            | 121   | 232-272 |
| Plate Gothics . . . . .                      | 94    | 273-302 |
| Law Italics . . . . .                        | 4     | 303-304 |
| Outlines . . . . .                           | 39    | 305-318 |
| Texts . . . . .                              | 14    | 319-324 |
| Typewriter . . . . .                         | 14    | 325-332 |
| German . . . . .                             | 21    | 333-342 |
| Greek . . . . .                              | 22    | 343-351 |
| Total Fonts . . . . .                        | 1175  |         |

This book does not show specimens of Monotype figures, fractions, signs, etc. There are a number of pages illustrating these in the regular Specimen Book of Monotype Type Faces.

# Index of Monotype Faces

| SERIES No. | ARRANGE-MENT | CLASS OF FACE | PAGE |
|------------|--------------|---------------|------|
| 1A         | C            | Modern        | 1    |
| 4A         | C            | "             | 2    |
| 5A         | C            | "             | 3    |
| 8A         | C            | "             | 5    |
| 11J        | C2           | Title         | 196  |
| 11         | Sorts        | "             | 198  |
| 11K        | C2           | "             | 199  |
| 1111       | Sorts        | "             | 200  |
| 12J        | C2           | Outline       | 305  |
| 12         | Sorts        | "             | 306  |
| 13A        | C            | Modern        | 8    |
| 14A        | C            | "             | 9    |
| 15E        | C            | Old Style     | 39   |
| 16E        | C            | "             | 41   |
| 17L        |              | Typewriter    | 325  |
| 19A        | C            | Modern        | 10   |
| 20A        | C            | "             | 11   |
| 20         | Sorts        | "             | 13   |
| 201        | Sorts        | "             | 14   |
| 21E        | C            | Old Style     | 43   |
| 21         | Sorts        | "             | 46   |
| 22E        | C            | "             | 48   |
| 23K        | C2           | Law Italic    | 303  |
| 25J        | C1           | Antique       | 123  |
| 25         | Sorts        | "             | 125  |
| 25K        | C1           | "             | 126  |
| 251        | Sorts        | "             | 128  |
| 26J        | C2           | "             | 129  |
| 28J        | C2           | Title         | 206  |
| 31E        | C            | Old Style     | 50   |
| 34A        | C            | Modern        | 15   |
| 35A        | C            | "             | 17   |
| 36A        | C            | "             | 18   |
| 36         | Sorts        | "             | 20   |
| 361        | "            | "             | 21   |
| 37E        | C            | Old Style     | 52   |
| 37         | Sorts        | "             | 54   |
| 371        | "            | "             | 55   |
| 38E        | C            | "             | 77   |
| 38         | Sorts        | "             | 79   |
| 381        | "            | "             | 80   |
| 39J        | C2           | Title         | 209  |
| 39         | Sorts        | "             | 210  |
| 40         | "            | Outline       | 307  |
| 41K        | C2           | "             | 308  |
| 41         | Sorts        | "             | 308  |
| 42J        | C2           | "             | 309  |
| 42         | Sorts        | "             | 310  |
| 44         | "            | "             | 311  |
| 45J        | C1           | Antique       | 133  |
| 45         | Sorts        | "             | 134  |
| 48J        | C            | Gothic        | 232  |
| 49J        | C1           | "             | 234  |
| 50         | Sorts        | "             | 235  |
| 51J        | C1           | "             | 236  |
| 51         | Sorts        | "             | 237  |
| 52J        | C2           | "             | 238  |
| 52         | Sorts        | "             | 239  |
| 56J        | C2           | Antique       | 135  |
| 58J        | C1           | "             | 139  |
| 58         | Sorts        | "             | 140  |

| SERIES No. | ARRANGE-MENT | CLASS OF FACE | PAGE |
|------------|--------------|---------------|------|
| 59         | Sorts        | Outline       | 312  |
| 60J        | C2           | Antique       | 143  |
| 60         | Sorts        | "             | 144  |
| 60K        | C2           | "             | 145  |
| 601        | Sorts        | "             | 146  |
| 61E        | C            | Old Style     | 81   |
| 62         | Sorts        | Antique       | 147  |
| 63J        | C2           | "             | 148  |
| 63         | Sorts        | "             | 149  |
| 64J        | C            | 64 Family     | 94   |
| 64         | Sorts        | "             | 95   |
| 64K        | C            | "             | 96   |
| 641        | Sorts        | "             | 97   |
| 66J        | C2           | Gothic        | 240  |
| 66         | Sorts        | "             | 241  |
| 68J        | C1           | Antique       | 150  |
| 68         | Sorts        | "             | 151  |
| 68K        | C2           | "             | 152  |
| 681        | Sorts        | "             | 153  |
| 69J        | C1           | "             | 154  |
| 69         | Sorts        | "             | 155  |
| 70L        |              | Typewriter    | 326  |
| 70         | Sorts        | "             | 327  |
| 71E        | C            | Old Style     | 83   |
| 71         | Sorts        | "             | 85   |
| 72L        |              | Typewriter    | 329  |
| 73         | Sorts        | Outline       | 312  |
| 75         | Sorts        | Text          | 324  |
| 76J        | C1           | Antique       | 131  |
| 77J        | C1           | Gothic        | 242  |
| 77         | Sorts        | "             | 243  |
| 78J        | C1           | Antique       | 156  |
| 78         | Sorts        | "             | 157  |
| 78K        | C1           | "             | 158  |
| 781        | Sorts        | "             | 159  |
| 79J        | C2           | Title         | 65   |
| 79         | Sorts        | "             | 67   |
| 79K        | C2           | "             | 68   |
| 791        | Sorts        | "             | 69   |
| 81J        | C4           | Antique       | 160  |
| 81         | Sorts        | "             | 161  |
| 83M        | Special      | Foreign       | 344  |
| 86J        | C2           | 64 Family     | 104  |
| 86         | Sorts        | "             | 106  |
| 86K        | C2           | "             | 107  |
| 861        | Sorts        | "             | 108  |
| 88J        | C1           | "             | 112  |
| 88         | Sorts        | "             | 113  |
| 88K        | C1           | "             | 114  |
| 881        | Sorts        | "             | 115  |
| 89J        | C1           | Title         | 211  |
| 89         | Sorts        | "             | 212  |
| 89K        | C1           | "             | 213  |
| 891        | Sorts        | "             | 214  |
| 92J        | C2           | Antique       | 162  |
| 94         | Sorts        | "             | 164  |
| 95J        | C3           | Text          | 319  |
| 95         | Sorts        | "             | 320  |
| 95M        | Special      | Foreign       | 333  |
| 96J        | C1           | Outline       | 313  |
| 96         | Sorts        | "             | 314  |



# Index of Monotype Faces

| SERIES No. | ARRANGE-MENT | CLASS OF FACE | PAGE |
|------------|--------------|---------------|------|
| 97J        | C2           | Antique       | 165  |
| 97         | Sorts        | "             | 166  |
| 97K        | C2           | "             | 167  |
| 98J        | C            | "             | 168  |
| 98         | Sorts        | "             | 169  |
| 98K        | C2           | "             | 170  |
| 99M        | GC           | Foreign       | 335  |
| 100M       | GC1          | "             | 337  |
| 100        | Sorts        | "             | 338  |
| 101        | "            | "             | 339  |
| 102J       | C3           | Text          | 321  |
| 102        | Sorts        | "             | 322  |
| 102M       | Special      | Foreign       | 340  |
| 103        | Sorts        | Title         | 215  |
| 104        | "            | Antique       | 173  |
| 107J       | C2           | Gothic        | 244  |
| 107        | Sorts        | "             | 245  |
| 108        | "            | Title         | 215  |
| 111J       | C1           | "             | 201  |
| 111        | Sorts        | "             | 203  |
| 113J       | C1           | "             | 70   |
| 113        | Sorts        | "             | 71   |
| 115C       | C2           | Law Italic    | 304  |
| 117J       | C1           | Antique       | 174  |
| 117        | Sorts        | "             | 175  |
| 117K       | C            | "             | 176  |
| 118J       | C1           | Title         | 72   |
| 118        | Sorts        | "             | 74   |
| 118K       | C2           | "             | 75   |
| 1181       | Sorts        | "             | 76   |
| 119J       | C1           | "             | 216  |
| 119        | Sorts        | "             | 217  |
| 120A       | C            | Modern        | 22   |
| 121        | Sorts        | Gothic        | 246  |
| 123        | "            | Outline       | 315  |
| 126        | "            | Initials      | 353  |
| 126A       | "            | "             | 353  |
| 127        | "            | "             | 354  |
| 128J       | C1           | Title         | 208  |
| 129        | Sorts        | Gothic        | 247  |
| 132K       | C2           | "             | 248  |
| 134EF      | C            | Old Style     | 86   |
| 137E       | C            | "             | 56   |
| 139J       | C1           | Antique       | 177  |
| 139        | Sorts        | "             | 178  |
| 140J       | C1           | Gothic        | 249  |
| 140        | Sorts        | "             | 250  |
| 141J       | C1           | 64 Family     | 116  |
| 141        | Sorts        | "             | 117  |
| 142J       | C2           | Antique       | 179  |
| 143J       | C            | "             | 183  |
| 143        | Sorts        | "             | 184  |
| 144        | "            | "             | 180  |
| 145J       | C2           | "             | 181  |
| 145        | Sorts        | "             | 182  |
| 146J       | C1           | Title         | 218  |
| 146        | Sorts        | "             | 219  |
| 149J       | C1           | Gothic        | 251  |
| 150A       | C            | Modern        | 23   |
| 150        | Sorts        | "             | 25   |
| 1501       | "            | "             | 26   |

| SERIES No. | ARRANGE-MENT | CLASS OF FACE | PAGE |
|------------|--------------|---------------|------|
| 152A       | C            | Modern        | 27   |
| 153J       | C2           | Antique       | 185  |
| 154E       | C            | Old Style     | 87   |
| 155M       | Special      | Foreign       | 345  |
| 156J       | C2           | Antique       | 137  |
| 157E       | C            | Old Style     | 88   |
| 157        | Sorts        | "             | 90   |
| 158J       | C2           | Title         | 220  |
| 158        | Sorts        | "             | 221  |
| 159J       | C2           | Antique       | 186  |
| 160M       | Special      | Foreign       | 347  |
| 161J       | C2           | Title         | 222  |
| 161        | Sorts        | "             | 223  |
| 161K       | C2           | "             | 224  |
| 162J       | C2           | "             | 225  |
| 162        | Sorts        | "             | 226  |
| 163J       | C2           | Antique       | 187  |
| 163        | Sorts        | "             | 188  |
| 164JB      | C            | 64 Family     | 98   |
| 164        | Sorts        | "             | 99   |
| 164K       | C            | "             | 100  |
| 1641       | Sorts        | "             | 101  |
| 165J       | C2           | Gothic        | 252  |
| 165        | Sorts        | "             | 253  |
| 166        | "            | Plate Gothic  | 290  |
| 168        | "            | "             | 284  |
| 169        | "            | "             | 288  |
| 170L       | "            | Typewriter    | 328  |
| 172E       | C            | Old Style     | 91   |
| 172        | Sorts        | "             | 93   |
| 173E       | C            | Antique       | 189  |
| 175A       | C            | Modern        | 28   |
| 175        | Sorts        | "             | 30   |
| 1751       | "            | "             | 31   |
| 176J       | C1           | Gothic        | 254  |
| 176        | Sorts        | "             | 255  |
| 186J       | C1           | 64 Family     | 109  |
| 186        | Sorts        | "             | 111  |
| 187        | "            | Plate Gothic  | 276  |
| 188J       | C2           | Text          | 323  |
| 188        | Sorts        | "             | 324  |
| 189J       | C2           | Antique       | 190  |
| 189        | Sorts        | "             | 191  |
| 193        | "            | Outline       | 316  |
| 194        | "            | "             | 38   |
| 197        | "            | Plate Gothic  | 280  |
| 199M       | GC           | Foreign       | 342  |
| 200M       | GC1          | "             | 342  |
| 202        | Sorts        | Outline       | 317  |
| 204J       | C4           | Gothic        | 256  |
| 204        | Sorts        | "             | 257  |
| 206        | "            | "             | 258  |
| 210J       | C4           | Title         | 204  |
| 210        | Sorts        | "             | 205  |
| 214A       | C            | Modern        | 9    |
| 216A       | C4           | "             | 58   |
| 218        | Sorts        | Outline       | 122  |
| 220J       | C2           | Antique       | 192  |
| 220        | Sorts        | "             | 193  |
| 221E       | C            | Old Style     | 47   |
| 222        | Sorts        | Gothic        | 258  |

# Index of Monotype Faces

| SERIES No. | ARRANGE-MENT | CLASS OF FACE | PAGE | SERIES No.             | ARRANGE-MENT | CLASS OF FACE | PAGE |
|------------|--------------|---------------|------|------------------------|--------------|---------------|------|
| 223        | Sorts        | Title (P. G.) | 300  | 311                    | Sorts        | Foreign       | 350  |
| 224K       | C2           | Gothic        | 259  | 318J                   | Special      | "             | 351  |
| 227        | Sorts        | "             | 260  | 323                    | Sorts        | Title (P. G.) | 302  |
| 230J       | C4           | "             | 261  | 328J                   | C2           | "             | 231  |
| 230        | Sorts        | "             | 262  | 337E                   | C            | Old Style     | 59   |
| 231J       | C            | Antique       | 227  | 337                    | Sorts        | "             | 62   |
| 231        | Sorts        | "             | 228  | 337I                   | "            | "             | 63   |
| 233J       | C2           | "             | 138  | 340J                   | P. G.        | Plate Gothic  | 273  |
| 239J       | C4           | Gothic        | 263  | 341J                   | "            | "             | 277  |
| 239        | Sorts        | "             | 264  | 342J                   | "            | "             | 281  |
| 240J       | C4           | "             | 265  | 343J                   | "            | "             | 285  |
| 240        | Sorts        | "             | 266  | 344J                   | "            | "             | 289  |
| 245        | "            | Title         | 229  | 345J                   | "            | "             | 291  |
| 246        | "            | Outline       | 318  | 346K                   | "            | "             | 295  |
| 249J       | C2           | Gothic        | 267  | 347J                   | "            | Title (P. G.) | 299  |
| 254K       | C2           | "             | 269  | 348J                   | "            | "             | 301  |
| 254I       | Sorts        | "             | 270  | 360J                   | C4           | Antique       | 194  |
| 255J       | C2           | Title         | 230  | 360                    | Sorts        | "             | 195  |
| 256J       | C            | Antique       | 138  | 366J                   | C2           | Gothic        | 271  |
| 258J       | C4           | "             | 141  | 366                    | Sorts        | "             | 272  |
| 258        | Sorts        | "             | 142  | 370L                   | "            | Typewriter    | 332  |
| 264J       | C            | 64 Family     | 102  | 375                    | Sorts        | Modern        | 32   |
| 264        | Sorts        | "             | 103  | 375I                   | "            | "             | 33   |
| 270L       | "            | Typewriter    | 330  | 475                    | "            | Foreign       | 324  |
| 272L       | "            | "             | 331  | 495                    | "            | "             | 334  |
| 275J       | C2           | Title         | 34   | 4102                   | "            | "             | 341  |
| 275        | Sorts        | "             | 35   | Arrows                 | "            | "             | 352  |
| 275K       | C2           | "             | 36   | Monotype rules         | "            | "             | 355  |
| 275I       | Sorts        | "             | 37   | Monotype corner pieces | "            | "             | 363  |
| 276        | "            | Gothic        | 268  | Set ems charts         | "            | "             | 377  |
| 285        | "            | 64 Family     | 118  | Monotype Borders       | "            | "             | 381  |
| 286        | "            | "             | 119  |                        |              |               |      |
| 287J       | C2           | "             | 120  |                        |              |               |      |
| 287        | Sorts        | "             | 121  |                        |              |               |      |
| 298J       | C4           | Antique       | 171  |                        |              |               |      |
| 298        | Sorts        | "             | 172  |                        |              |               |      |
| 308AC      | Special      | Foreign       | 349  |                        |              |               |      |

# USE OF "WORDS TO PICA"

IT HAS been our practice in the past to include on the specimen sheets showing the cellular sizes of each series the information "Words to Pica," but with the perfection and rapidly expanding use of the more accurate system, "Copyfitting," this information will be omitted when present sheets are reprinted.

For the convenience of those who are now using the "Words to Pica" system we have worked out the table herewith, which gives all the information formerly included on the specimen sheets, with directions how to use. When making calculations, use the figures given in the table, not those given on your present specimen sheets, some of which we have found to be incorrect.

## "WORDS TO PICA" CHART

**HOW TO USE:** Divide "Words to Pica," of selected arrangement and set size, INTO, number of words of copy, AND, result will be number of picas copy will make.

| Set         | C Arrangement |            |            |        |            | C1 Arrangement |            | C2 Arrangement |            | C3 Arrangement |            | C4 Arrangement |            |
|-------------|---------------|------------|------------|--------|------------|----------------|------------|----------------|------------|----------------|------------|----------------|------------|
|             | Roman         |            |            | Italic |            | Caps           | Lower Case | Caps           | Lower Case | Caps           | Lower Case | Caps           | Lower Case |
|             | Caps          | Small Caps | Lower Case | Caps   | Lower Case |                |            |                |            |                |            |                |            |
| 5           | .58           | .80        | .88        | .58    | .95        | .62            | .88        | .58            | .77        | .54            | 1.00       | .69            | .88        |
| 5½          | .56           | .76        | .84        | .56    | .90        | .59            | .84        | .56            | .74        | .52            | .95        | .66            | .84        |
| 5¾          | .53           | .73        | .80        | .53    | .86        | .56            | .80        | .53            | .70        | .49            | .91        | .63            | .80        |
| 5⅞          | .51           | .69        | .77        | .51    | .82        | .54            | .77        | .51            | .67        | .47            | .87        | .60            | .77        |
| 6           | .49           | .66        | .73        | .49    | .79        | .51            | .73        | .49            | .65        | .45            | .83        | .57            | .73        |
| 6¼          | .47           | .64        | .70        | .47    | .76        | .49            | .70        | .47            | .62        | .44            | .80        | .55            | .70        |
| 6½          | .45           | .61        | .68        | .45    | .73        | .47            | .68        | .45            | .60        | .42            | .77        | .53            | .68        |
| 6¾          | .43           | .59        | .65        | .43    | .70        | .46            | .65        | .43            | .57        | .40            | .74        | .51            | .65        |
| 7           | .42           | .57        | .63        | .42    | .68        | .44            | .63        | .42            | .55        | .39            | .71        | .49            | .63        |
| 7¼          | .40           | .55        | .61        | .40    | .65        | .43            | .61        | .40            | .53        | .38            | .69        | .47            | .61        |
| 7½          | .39           | .53        | .59        | .39    | .63        | .41            | .59        | .39            | .52        | .36            | .67        | .46            | .59        |
| 7¾          | .38           | .51        | .57        | .38    | .61        | .40            | .57        | .38            | .50        | .35            | .65        | .44            | .57        |
| 8           | .36           | .50        | .55        | .36    | .59        | .39            | .55        | .36            | .48        | .34            | .63        | .43            | .55        |
| 8¼          | .35           | .48        | .53        | .35    | .57        | .37            | .53        | .35            | .47        | .33            | .61        | .42            | .53        |
| 8½          | .34           | .47        | .52        | .34    | .56        | .36            | .52        | .34            | .46        | .32            | .59        | .40            | .52        |
| 8¾          | .33           | .46        | .50        | .33    | .54        | .35            | .50        | .33            | .44        | .31            | .57        | .39            | .50        |
| 9           | .32           | .44        | .49        | .32    | .53        | .34            | .49        | .32            | .43        | .30            | .56        | .38            | .49        |
| 9¼          | .32           | .43        | .48        | .32    | .51        | .33            | .48        | .32            | .42        | .29            | .54        | .37            | .48        |
| 9½          | .31           | .42        | .46        | .31    | .50        | .32            | .46        | .31            | .41        | .29            | .53        | .36            | .46        |
| 9¾          | .30           | .41        | .45        | .30    | .48        | .32            | .45        | .30            | .40        | .28            | .51        | .35            | .45        |
| 10          | .29           | .40        | .44        | .29    | .47        | .31            | .44        | .29            | .39        | .27            | .50        | .34            | .44        |
| 10¼         | .28           | .39        | .43        | .28    | .46        | .30            | .43        | .28            | .38        | .27            | .49        | .34            | .43        |
| 10½         | .28           | .38        | .42        | .28    | .45        | .29            | .42        | .28            | .37        | .26            | .48        | .33            | .42        |
| 10¾         | .27           | .37        | .41        | .27    | .44        | .29            | .41        | .27            | .36        | .25            | .47        | .32            | .41        |
| 11          | .27           | .36        | .40        | .27    | .43        | .28            | .40        | .27            | .35        | .25            | .45        | .31            | .40        |
| 11¼         | .26           | .35        | .39        | .26    | .42        | .27            | .39        | .26            | .34        | .24            | .44        | .31            | .39        |
| 11½         | .25           | .35        | .38        | .25    | .41        | .27            | .38        | .25            | .34        | .24            | .43        | .30            | .38        |
| 11¾         | .25           | .34        | .37        | .25    | .40        | .26            | .37        | .25            | .33        | .23            | .42        | .29            | .37        |
| 12          | .24           | .33        | .37        | .24    | .39        | .26            | .37        | .24            | .32        | .23            | .42        | .29            | .37        |
| 12¼         | .24           | .33        | .36        | .24    | .39        | .25            | .36        | .24            | .32        | .22            | .41        | .28            | .36        |
| 12½         | .23           | .32        | .35        | .23    | .38        | .25            | .35        | .23            | .31        | .22            | .40        | .27            | .35        |
| 14          | .21           |            | .31        | .21    | .34        |                |            | .21            | .28        |                |            |                |            |
| 18          | .16           |            | .24        | .16    | .26        |                |            | .16            | .22        |                |            |                |            |
| Word Length | 4.08          | 3.01       | 2.73       | 4.10   | 2.54       | 3.89           | 2.73       | 4.11           | 3.10       | 4.41           | 2.40       | 3.49           | 2.73       |

# No. 1A. Book Arrangement C

## Composition Matrices

6 Point No. 1A, 6 Set

### MONOTYPE FACES

The best kind of originality is that which comes after a sound apprenticeship; that which shall prove to be the blending of a firm conception of all useful precedent and the progressive tendencies of an able mind. For, let a man be as able and original as he may, he cannot afford to discard knowledge of what has gone before or what is now going on in his own trade and profession. If the printers of today do not wish to be esteemed arrogant when they term this calling of theirs an art, they must be willing, and show that they are willing, to subject it to such laws as have made its sister arts so free. All those concerned in what are accepted as the fine arts, the learned sciences, and professions surround themselves with the history, literature, and concrete examples of the work with which they are particularly engaged. Yet it is only in rare instances that such an atmosphere, with its material appurtenances, is to be found in a printing office. Art does not flourish in hidden places, nor under restraint, nor in ignorance of what talent and genius have accomplished and are accomplishing throughout the world. For to follow precedent wisely does not mean to imitate slavishly one great exemplar, but to study all masters faithfully, letting their great achievements sink slowly into the mind in order that we may patiently derive from the richness of our acquired knowledge and organized system an attitude of our own. The sprightly minded young man, who with his first business breath projects the new and startling, inevitably becomes tiresome, and is driven to an early disappearance; while the slower, more solidly endowed student will at least spend as much of his time in avoiding mistakes as in evolving the brilliant schemes wherewith to dazzle his contemporaries. The best kind of originality is that which comes after a sound apprenticeship; that which shall prove to be the blending of a firm conception of all useful precedent and the progressive tendencies of an able mind. For, let a man be as able and original as he may, he cannot afford to discard knowledge of what has gone before or what is now going on in his own trade and profession. If the printers of today do not wish to be esteemed arrogant when they term this calling of theirs an art, they must be willing, and show that they are willing, to subject it to such laws as have made its sister arts so free. All those concerned in what are accepted as the fine arts, the learned sciences, and professions surround themselves with the history, literature, and concrete examples of the work with which they are particularly engaged. Yet it is only in rare instances that such an atmosphere, with its material appurtenances, is to be found in a printing office. Art does not flourish in hidden places, nor under restraint, nor in ignorance of what talent

12345                    abedefghijklmnopqrstuvwxy                    67890\$  
 ABCDEFGHIJKLMNOPQRSTUVWXYZ  
 12345                    abedefghijklmnopqrstuvwxy                    67890\$  
 ABCDEFGHIJKLMNOPQRSTUVWXYZ

8 Point No. 1A, 7 Set

### MONOTYPE FACES

The best kind of originality is that which comes after a sound apprenticeship; that which shall prove itself to be the blending of a firm conception of useful precedent and the progressive tendencies of an able mind. For, let a man be as able and original as he may, he cannot afford to discard knowledge of what has gone before or what is now going on in his own trade and profession. If the printers of today do not wish to be esteemed arrogant, when they term this calling of theirs an art, they must be willing, and show that they are willing, to subject it to such laws as have made its sister arts so free. All those concerned in what are accepted as the fine arts, the learned sciences, and professions surround themselves with the history, literature, and concrete examples of work with which they are particularly engaged. Yet it is only in very rare instances that such an atmosphere, with its material appurtenances, is to be found in a printing office. Art does not flourish in hidden places, nor under restraint, nor in ignorance of what talent and genius have accomplished and are accomplishing throughout the world. For to follow precedent wisely does not mean to imitate slavishly one great exemplar, but to study all the masters faithfully, letting their great achievements sink slowly into the mind in order that we may patiently derive from the richness of our acquired knowledge and organized system an attitude of our own. The sprightly minded young man, who with his first business breath projects the new and startling, inevitably becomes tiresome, and is driven to an early disappearance; while the slower and more solidly endowed student will at least spend as much of his time in avoiding mistakes as in evolving brilliant schemes wherewith to dazzle his contem-

12345                    abedefghijklmnopqrstuvwxy                    67890\$  
 ABCDEFGHIJKLMNOPQRSTUVWXYZ  
 12345                    abedefghijklmnopqrstuvwxy                    67890\$  
 ABCDEFGHIJKLMNOPQRSTUVWXYZ

10 Point No. 1A, 9 Set

### MONOTYPE FACES

The best kind of originality is that which comes after a sound apprenticeship; that which shall prove itself to be the blending of a firm conception of useful precedent and the progressive tendencies of an able mind. For, let a man be as able and original as he may, he cannot afford to discard knowledge of what has gone before or what is now going on in his own trade and profession. If the printers of today do not wish to be esteemed arrogant when they term this calling of theirs an art, they must be willing, and show that they are willing, to subject it to such laws as have made its sister arts so free. All those concerned in what are accepted as the fine arts, the learned sciences, and the professions surround themselves with the history, literature, and con-

12345                    abedefghijklmnopqrstuvwxy                    67890\$  
 ABCDEFGHIJKLMNOPQRSTUVWXYZ  
 12345                    abedefghijklmnopqrstuvwxy                    67890\$  
 ABCDEFGHIJKLMNOPQRSTUVWXYZ  
 ABCDEFGHIJKLMNOPQRSTUVWXYZ

### MONOTYPE FACES

The best kind of originality is that which comes after a sound apprenticeship; that which shall prove itself to be the blending of a firm conception of useful precedent and the progressive tendencies of an able mind. For, let a man be as able and original as he may, he cannot afford to discard knowledge of what has gone before or what is now going on in his own trade and profession. If the printers of today do not wish to be esteemed arrogant when they term this calling of theirs an art, they must be willing, and show that they are willing, to subject it to such laws as have made its sister arts so free. All those concerned in what are accepted as the fine arts, the learned sciences, and professions surround themselves with the history, literature, and concrete examples of work with which they are particularly engaged. Yet it is only in very rare instances that such an atmosphere, with its material appurtenances,

# No. 4A. Book Arrangement C

## Composition Matrices

10 Point No. 4A, 10 Set

### MONOTYPE FACES

The best kind of originality is that which comes after a sound apprenticeship; that which shall prove to be the blending of a firm conception of all useful precedent and the progressive tendencies of an able mind. For, let a man be as able and original as he may, he cannot afford to discard knowledge of what has gone before or what is now going on in his own trade and profession. If the printers of today do not wish to be esteemed arrogant when they term this calling of theirs an art, they must be willing, and show that they are willing, to subject it to such laws as have made its sister arts so free. All those who are concerned in what are accepted as the fine arts, the learned sciences, and the professions surround themselves with the history, the literature, and *concrete examples of the work with which they may be particularly engaged. Yet it is only in very rare*

### MONOTYPE FACES

The best kind of originality is that which comes after a sound apprenticeship; that which shall prove to be the blending of a firm conception of all useful precedent and the progressive tendencies of an able mind. For, let a man be as able and original as he may, he cannot afford to discard knowledge of what has gone before or what is now going on in his own trade and profession. If the printers of today do not wish to be esteemed arrogant when they term this calling of theirs an art, they must be willing, and show that they are willing, to subject it to such laws as have made its sister arts so free. All those who are concerned in what are accepted as the fine arts, the learned sciences, and the professions surround themselves with the history, the literature, and concrete examples of the work with which they are particularly engaged. Yet it is only in very rare instances that such an atmosphere, with its *material appurtenances, is to be found in the printing office. Art does not flourish in hidden places, nor*

12345 abcdefghijklmnopqrstuvwxyz 67890\$

ABCDEFGHIJKLMNOPQRSTUVWXYZ

ABCDEFGHIJKLMNOPQRSTUVWXYZ

12345 abcdefghijklmnopqrstuvwxyz 67890\$

ABCDEFGHIJKLMNOPQRSTUVWXYZ

# No. 5A. Book Arrangement C

## Composition Matrices

5½ Point No. 5A, 7½ Set

### MONOTYPE FACES

The best kind of originality is that which comes after a sound apprenticeship; that which shall prove to be the blending of a firm conception of all useful precedent and the progressive tendencies of an able mind. For, let a man be as able and original as he may, he cannot afford to discard knowledge of what has gone before or what is now going on in his own trade and profession. If the printers of today do not wish to be esteemed arrogant when they term this calling of theirs an art, they must be willing, and show that they are willing, to subject it to such laws as have made its sister arts so free. All those concerned in what are accepted as the fine arts, the learned sciences, and professions surround themselves with the history, literature, and concrete examples of the work with which they are particularly engaged. Yet it is only in rare instances that such an atmosphere, with its material appurtenances, is to be found in a printing office. Art does not flourish in hidden places, nor under restraint, nor in ignorance of what talent and genius have accomplished and are accomplishing throughout the world. For to follow precedent wisely does not mean to imitate slavishly one great exemplar, but to study all masters faithfully, letting their great achievements sink slowly into the mind in order that we may patiently derive from the richness of our acquired knowledge and organized system an attitude of our own. The sprightly minded young man, who with his first business breath projects the new and startling, inevitably becomes tiresome, and is driven to an early disappearance; while the slower, more solidly endowed student will at least spend as much of his time in avoiding mistakes as in evolving brilliant schemes wherewith to dazzle his contemporaries. The best kind of originality is that which comes after a sound apprenticeship; that which shall prove to be the blending of a firm conception of all useful precedent and the progressive tendencies of an able mind. For, let a man be as able and original as he may, he cannot afford to discard knowledge of what has gone before or what is now going on in his own trade and profession. If

|       |                            |         |
|-------|----------------------------|---------|
| 12345 | abcdefghijklmnopqrstuvwxy  | 67890\$ |
|       | ABCDEFGHIJKLMNOPQRSTUVWXYZ |         |
|       | ABCDEFGHIJKLMNOPQRSTUVWXYZ |         |
| 12345 | abcdefghijklmnopqrstuvwxy  | 67890\$ |
|       | ABCDEFGHIJKLMNOPQRSTUVWXYZ |         |

7 Point No. 5A, 8½ Set

### MONOTYPE FACES

The best kind of originality is that which comes after a sound apprenticeship; that which shall prove to be the blending of a firm conception of all useful precedent and the progressive tendencies of an able mind. For, let any man be as able and original as he may, he cannot afford to discard knowledge of what has gone before or what is now going on in his own trade and profession. If the printers of today do not wish to be esteemed arrogant when they term this calling of theirs an art, they must be willing, and show that they are willing, to subject it to such laws as have made its sister arts so free. All those concerned in what are accepted as the fine arts, the learned sciences, and the professions surround themselves with the history, the literature, and concrete examples of the work with which they are more particularly engaged. Yet it is only in rare instances that such an atmosphere, with its material appurtenances, is to be found in a printing office. Art does not flourish in hidden places, nor under restraint, nor in ignorance of what talent and genius have accomplished and are now accomplishing throughout the world. For to follow precedent wisely does not mean to imitate slavishly one great exemplar, but to study all the masters faithfully, letting their greatest achievements sink slowly into the mind in order that we may patiently derive from the richness of our acquired knowledge and organized system an attitude of our own. The sprightly minded young man, who with his first business breath projects the new and startling, inevitably becomes tiresome, and is driven to an early

|       |                            |         |
|-------|----------------------------|---------|
| 12345 | abcdefghijklmnopqrstuvwxy  | 67890\$ |
|       | ABCDEFGHIJKLMNOPQRSTUVWXYZ |         |
|       | ABCDEFGHIJKLMNOPQRSTUVWXYZ |         |
| 12345 | abcdefghijklmnopqrstuvwxy  | 67890\$ |
|       | ABCDEFGHIJKLMNOPQRSTUVWXYZ |         |

6 Point No. 5A, 7½ Set

### MONOTYPE FACES

The best kind of originality is that which comes after a sound apprenticeship; that which shall prove itself to be the blending of a firm conception of all useful precedent and the progressive tendencies of an able mind. For, let a man be as able and original as he may, he cannot afford to discard knowledge of what has gone before or what is now going on in his own trade and profession. If all the printers of today do not wish to be esteemed arrogant when they term this calling of theirs an art they must be willing, and show that they are willing, to subject it to such laws as have made its sister arts so free. All those concerned in what are accepted as the fine arts, the learned sciences, and professions surround themselves with the history, literature, and concrete examples of the work with which they are particularly engaged. Yet it is only in very rare instances that such an atmosphere, with all its material appurtenances, is to be found in a printing office. Art does not flourish in hidden places, nor under restraint, nor in ignorance of all that talent and genius have accomplished and are now accomplishing throughout the world. For to follow all precedent wisely does not mean to imitate slavishly one great exemplar, but to study all the masters faithfully, letting their great achievements sink slowly into the mind in order that we may patiently derive from the richness of all our acquired knowledge and organized system an attitude of our own. The sprightly minded young man, who with his first business breath projects the new and the startling, inevitably becomes tiresome, and is driven to an early disappearance; while the slower, the more solidly endowed student will at least spend as much of his time in avoiding mistakes as in evolving brilliant schemes wherewith to dazzle his contemporaries. The best kind of originality is that which comes after

|       |                            |         |
|-------|----------------------------|---------|
| 12345 | abcdefghijklmnopqrstuvwxy  | 67890\$ |
|       | ABCDEFGHIJKLMNOPQRSTUVWXYZ |         |
|       | ABCDEFGHIJKLMNOPQRSTUVWXYZ |         |
| 12345 | abcdefghijklmnopqrstuvwxy  | 67890\$ |
|       | ABCDEFGHIJKLMNOPQRSTUVWXYZ |         |

8 Point No. 5A, 9 Set

### MONOTYPE FACES

The best kind of originality is that which comes after a sound apprenticeship; that which shall prove to be the blending of a firm conception of all useful precedent and the progressive tendencies of an able mind. For, let a man be as able and original as he may, he cannot afford to discard knowledge of what has gone before or what is now going on in his own trade and profession. If the printers of today do not wish to be esteemed too arrogant when they term this calling of theirs an art, they must be willing, and show that they are willing, to subject it to such laws as have made its sister arts so free. All those concerned in what are accepted as the fine arts, the learned sciences, and the professions surround themselves with the history, literature, and concrete examples of the work with which they are particularly engaged. Yet it is only in rare instances that such an atmosphere, with its material appurtenances, is to be found in a printing office. Art does not flourish in hidden places, nor under restraint, nor in ignorance of what talent and genius have accomplished and are accomplishing throughout the world. For to follow precedent wisely does not mean to imitate slavishly one great exemplar, but to study all masters faithfully, letting their great achievements sink slowly into the mind

|       |                            |         |
|-------|----------------------------|---------|
| 12345 | abcdefghijklmnopqrstuvwxy  | 67890\$ |
|       | ABCDEFGHIJKLMNOPQRSTUVWXYZ |         |
|       | ABCDEFGHIJKLMNOPQRSTUVWXYZ |         |
| 12345 | abcdefghijklmnopqrstuvwxy  | 67890\$ |
|       | ABCDEFGHIJKLMNOPQRSTUVWXYZ |         |

# No. 5A. Book Arrangement C

## Composition Matrices

9 Point No. 5A, 9½ Set

### MONOTYPE FACES

The best kind of originality is that which comes after a sound apprenticeship; that which shall prove to be the blending of a firm conception of all useful precedent and the progressive tendencies of an able mind. For, let any man be as able and original as he may, he cannot afford to discard knowledge of what has gone before or what is now going on in his own trade and profession. If the printers of today do not wish to be esteemed too arrogant when they term this calling of theirs an art, they must be willing, and show that they are willing, to subject it to such laws as have made its sister arts so free. All those concerned in what are accepted as the fine arts, the learned sciences, and the professions surround themselves with the history, the literature and concrete examples of the work with which they are particularly engaged. Yet it is only in rare instances that such an atmosphere, with its material appurtenances, is to be found in a printing office. Art does not flourish in hidden places, nor under restraint, nor in ignorance of what talent and genius have accomplished and

12345    abcdefghijklmnopqrstuvwxyz    67890\$

ABCDEFGHIJKLMNOPQRSTUVWXYZ

ABCDEFGHIJKLMNOPQRSTUVWXYZ

12345    abcdefghijklmnopqrstuvwxyz    67890\$

ABCDEFGHIJKLMNOPQRSTUVWXYZ

11 Point No. 5A, 11½ Set

### MONOTYPE FACES

The best kind of originality is that which comes after a sound apprenticeship; that which shall prove to be the blending of a firm conception of all useful precedent and the progressive tendencies of an able mind. For, let any man be as able and as original as he may, he cannot well afford to discard knowledge of what has gone before or what is now going on in his own trade and profession. If the printers of today do not wish to be esteemed too arrogant when they term this calling of theirs an art, they must be willing, and show that they are willing, to subject it to such laws as have made its sister arts so free. All those concerned in what are accepted as the fine arts, the learned sciences, and the professions sur-

1234    abcdefghijklmnopqrstuvwxyz    567\$

ABCDEFGHIJKLMNOPQRSTUVWX

ABCDEFGHIJKLMNOPQRSTUVWXYZ

123456    abcdefghijklmnopqrstuvwxyz    7890\$

ABCDEFGHIJKLMNOPQRSTUVWX

# The Monotype System

COMPOSING room efficiency can be obtained only by keeping clearly in mind this fact: *The composing room of a printing plant is a great deal more than a place in which to operate composing machines; it is a department maintained to produce composition complete, locked-up in chases ready for printing.*

THE MONOTYPE is the only composing machine that recognizes the existence of the hand compositor. It is not built upon the impossible theory that the compositor can be driven from the printing industry; instead, it provides the means for increasing his efficiency and making his work highly profitable to his employer.

NOT ONLY does the Monotype furnish a

product that the compositor can correct and alter without the help of the machine operator, but also, since it is a complete type foundry, it supplies the compositor with all the equipment he requires to work efficiently—type, space material, rules, leads, and slugs.

THE MONOTYPE is the simplest and fastest composing machine, a machine so free from mechanical limitations that it handles the most intricate composition as easily as straight matter.

THE MONOTYPE SYSTEM increases the efficiency of every composing room employee by eliminating distribution, thus giving a much lower cost than is possible with any other composing machine.

## No. 8A. Book Arrangement C

### Composition Matrices

4 Point No. 8A, 5 Set

#### MONOTYPE FACES

The best kind of originality is that which comes after a sound apprenticeship; that which shall prove to be the blending of a firm conception of all useful precedent and the progressive tendencies of an able mind. For, let a man be as able and original as he may, he cannot afford to discard knowledge of what has gone before or what is now going on in his own trade and profession. If the printers of today do not wish to be esteemed arrogant when they term this calling of theirs an art, they must be willing, and show that they are willing, to subject it to such laws as have made its sister arts so free. All those concerned in what are accepted as the fine arts, the learned sciences, and professions, surround themselves with the history, the literature, and concrete examples of the work with which they may be particularly engaged. Yet it is only in rare instances that such an atmosphere, with its material appurtenances, is to be found in a printing office. Art does not flourish in hidden places, nor under restraint, nor in ignorance of what talent and genius have accomplished and are now accomplishing throughout the world. For to follow precedent wisely does not mean to imitate slavishly one great exemplar, but to study all the masters faithfully, letting their great achievements sink slowly into the mind in order that we may patiently derive from the richness of our acquired knowledge and organized system an attitude of our own. The sprightly minded young man, who with his first business breath projects the new and startling, inevitably becomes tiresome, and is driven to an early disappearance; while the slower, more solidly endowed student will at least spend as much of his time in avoiding mistakes as in evolving brilliant schemes wherewith to dazzle his contemporaries. The best kind of originality is that which comes after a sound apprenticeship; that which shall prove to be the blending of a firm conception of all useful precedent and the progressive tendencies of an able mind. For, let a man be as able and original as he may, he cannot afford to discard knowledge of what has gone before or what is now going on in his own trade and profession. If the printers of today do not wish to be esteemed arrogant when they term this calling of theirs an art, they must be willing, and show that they are willing, to subject it to such laws as have made its sister arts so free. All those concerned in what are accepted as the fine arts, the learned sciences, and professions surround themselves with the history, the literature, and con-

|       |                            |       |
|-------|----------------------------|-------|
| 12345 | abedefghijklmnopqrstuvwxy  | 67890 |
|       | ABCDEFGHIJKLMNOPQRSTUVWXYZ |       |
|       | abcdefghijklmnopqrstuvwxy  |       |
| 12345 | abedefghijklmnopqrstuvwxy  | 67890 |
|       | ABCDEFGHIJKLMNOPQRSTUVWXYZ |       |

4½ Point No. 8A, 6 Set on 5 Point Body

#### MONOTYPE FACES

The best kind of originality is that which comes after a sound apprenticeship; that which shall prove to be the blending of a firm conception of all useful precedent and the progressive tendencies of an able mind. For, let a man be as able and original as he may, he cannot afford to discard knowledge of what has gone before or what is now going on in his own trade and profession. If the printers of today do not wish to be esteemed arrogant when they term this calling of theirs an art, they must be willing, and show that they are willing, to subject it to such laws as have made its sister arts so free. All those concerned in what are accepted as the fine arts, the learned sciences, and professions surround themselves with the history, literature, and concrete examples of the work with which they are particularly engaged. Yet it is only in rare instances that such an atmosphere, with its material appurtenances, is to be found in a printing office. Art does not flourish in hidden places, nor under restraint, nor in ignorance of what talent and genius have accomplished and are accomplishing throughout the world. For to follow precedent wisely does not mean to imitate slavishly one great exemplar, but to study all the masters faithfully, letting their great achievements sink slowly into the mind in order that we may patiently derive from the richness of our acquired knowledge and organized system an attitude of our own. The sprightly minded young man, who with his first business breath projects the new and startling, inevitably becomes tiresome, and is driven to an early disappearance; while the slower, more solidly endowed student will at least spend as much of his time in avoiding mistakes as in evolving brilliant schemes wherewith to dazzle his contemporaries. The best kind of originality is that which comes after a sound apprenticeship; that which shall prove to be the blending of a firm conception of all useful precedent and the progressive tendencies of an able mind. For, let a man be as able and original as he may, he cannot afford to discard knowledge of what

|       |                            |       |
|-------|----------------------------|-------|
| 12345 | abedefghijklmnopqrstuvwxy  | 67890 |
|       | ABCDEFGHIJKLMNOPQRSTUVWXYZ |       |
|       | abcdefghijklmnopqrstuvwxy  |       |
| 12345 | abedefghijklmnopqrstuvwxy  | 67890 |
|       | ABCDEFGHIJKLMNOPQRSTUVWXYZ |       |



# No. 8A. Book Arrangement C

## Composition Matrices

### 5 Point No. 8A, 6½ Set

#### MONOTYPE FACES

The best kind of originality is that which comes after a sound apprenticeship; that which shall prove to be the blending of a firm conception of all useful precedent and the progressive tendencies of an able mind. For, let a man be as able and original as he may, he cannot afford to discard knowledge of what has gone before or what is now going on in his own trade and profession. If the printers of today do not wish to be esteemed arrogant when they term this calling of theirs an art, they must be willing, and show that they are willing, to subject it to such laws as have made its sister arts so free. All those concerned in what are accepted as the fine arts, the learned sciences, and the professions surround themselves with the history, literature, and concrete examples of the work with which they are particularly engaged. Yet it is only in rare instances that such an atmosphere, with its material appurtenances, is to be found in a printing office. Art does not flourish in hidden places, nor under restraint, nor in ignorance of what talent and genius have accomplished and are accomplishing throughout the world. For to follow all precedent wisely does not mean to imitate slavishly one great exemplar, but to study all masters faithfully, letting their great achievements sink slowly into the mind in order that we may patiently derive from the richness of our acquired knowledge and organized system an attitude of our own. The sprightly minded young man, who with his first business breath projects the new and startling, inevitably becomes tiresome, and is driven to an early disappearance; while the slower, more solidly endowed student will at least spend as much of his time in avoiding mistakes as in evolving brilliant schemes wherewith to dazzle his contemporaries. The best kind of originality is that which comes after a sound apprenticeship; that which shall prove to be the blending of a firm conception of all useful precedent and the progressive tendencies of an able mind. For, let any man be as able and original as he may, he cannot well afford to discard knowledge of what has gone before or is now going on in his own trade and profession. If the printers of today do not wish to be esteemed arrogant when they term this calling of theirs an art, they must be willing, and show that they are willing, to subject it to such laws as have made its sister arts so free. All those concerned in what are accepted as the fine arts, the learned sciences, and professions surround themselves with the history, literature, and concrete examples of the work with which they are particularly engaged. Yet it is only in very rare instances that such an atmosphere, with its material

|       |                            |       |
|-------|----------------------------|-------|
| 12345 | abcdefghijklmnopqrstuvwxy  | 67890 |
|       | ABCDEFGHIJKLMNOPQRSTUVWXYZ |       |
|       | abcdefghijklmnopqrstuvwxy  |       |
| 12345 | abcdefghijklmnopqrstuvwxy  | 67890 |
|       | ABCDEFGHIJKLMNOPQRSTUVWXYZ |       |

### 7 Point No. 8A, 8 Set

#### MONOTYPE FACES

The best kind of originality is that which comes after a sound apprenticeship; that which shall prove to be the blending of a firm conception of all useful precedent and the progressive tendencies of an able mind. For, let a man be as able and original as he may, he cannot afford to discard knowledge of what has gone before or what is now going on in his own trade and profession. If the printers of today do not wish to be esteemed arrogant when they term this calling of theirs an art, they must be willing, and show that they are willing, to subject it to such laws as have made its sister arts so free. All those concerned in what are accepted as the fine arts, the learned sciences, and the professions surround themselves with the history, literature, and the concrete examples of the work with which they are particularly engaged. Yet it is only in rare instances that such an atmosphere, with its material appurtenances, is to be found in a printing office. Art does not flourish in hidden places, nor under restraint, nor in ignorance of what talent and genius have accomplished and are accomplishing throughout the world. For to follow precedent wisely does not mean to imitate slavishly one great exemplar, but to study all masters faithfully, letting their great achievements sink slowly into the mind in order that we may patiently derive from the richness of our acquired knowledge and organized system an attitude of our own. The sprightly minded young man, who with his first business breath projects the new and startling, inevitably becomes tiresome, and is driven to an early disappearance; while the slower, more solidly endowed student will at least spend as much of his time in avoiding mistakes

|       |                            |       |
|-------|----------------------------|-------|
| 12345 | abcdefghijklmnopqrstuvwxy  | 67890 |
|       | ABCDEFGHIJKLMNOPQRSTUVWXYZ |       |
|       | abcdefghijklmnopqrstuvwxy  |       |
| 12345 | abcdefghijklmnopqrstuvwxy  | 67890 |
|       | ABCDEFGHIJKLMNOPQRSTUVWXYZ |       |

### 6 Point No. 8A, 7 Set

#### MONOTYPE FACES

The best kind of originality is that which comes after a sound apprenticeship; that which shall prove itself to be the blending of a firm conception of useful precedent and the progressive tendencies of an able mind. For, let a man be as able and original as he may, he cannot afford to discard knowledge of what has gone before or what is now going on in his own trade and profession. If the printers of today do not wish to be esteemed arrogant, when they term this calling of theirs an art, they must be willing, and show that they are willing, to subject it to such laws as have made its sister arts so free. All those concerned in what are accepted as the fine arts, the learned sciences, and professions surround themselves with the history, literature, and concrete examples of work with which they are particularly engaged. Yet it is only in very rare instances that such an atmosphere, with its material appurtenances, is to be found in the printing office. Art does not flourish in hidden places, nor under restraint, nor in ignorance of what talent and genius have accomplished and are accomplishing throughout the world. For to follow precedent wisely does not mean to imitate slavishly one great exemplar, but to study all masters faithfully, letting their great achievements sink slowly into the mind in order that we may patiently derive from the richness of our acquired knowledge and organized system an attitude of our own. The sprightly minded young man, who with his first business breath projects the new and startling, inevitably becomes tiresome, and is driven to an early disappearance; while the slower and more solidly endowed student will at least spend as much of his time in avoiding mistakes as in evolving brilliant schemes wherewith to dazzle his contemporaries. The best kind of originality is that which comes after a sound apprenticeship; that which shall prove itself to be the blending of a firm conception of all useful precedent and the progressive tendencies of an able mind. For, let any man be as able and original as he

|       |                            |       |
|-------|----------------------------|-------|
| 12345 | abcdefghijklmnopqrstuvwxy  | 67890 |
|       | ABCDEFGHIJKLMNOPQRSTUVWXYZ |       |
|       | abcdefghijklmnopqrstuvwxy  |       |
| 12345 | abcdefghijklmnopqrstuvwxy  | 67890 |
|       | ABCDEFGHIJKLMNOPQRSTUVWXYZ |       |

### 8 Point No. 8A, 8½ Set

#### MONOTYPE FACES

The best kind of originality is that which comes after a sound apprenticeship; that which shall prove to be the blending of a firm conception of all useful precedent and the progressive tendencies of an able mind. For, let a man be as able and original as he may, he cannot afford to discard knowledge of what has gone before or what is now going on in his own trade and profession. If the printers of today do not wish to be esteemed arrogant when they term this calling of theirs an art, they must be willing, and show that they are willing, to subject it to such laws as have made its sister arts so free. All those concerned in what are accepted as the fine arts, the learned sciences, and the professions surround themselves with the history, literature, and the concrete examples of the work with which they are particularly engaged. Yet it is only in very rare instances that such an atmosphere, with its material appurtenances, is to be found in a printing office. Art does not flourish in hidden places, nor under restraint, nor in ignorance of what talent and genius have accomplished and are now accomplishing throughout the world. For to follow precedent wisely does not mean to imitate slavishly one great exemplar, but to study all the masters faithfully, letting their great achievements sink slowly into the mind in order that we may patiently derive from the richness

|       |                            |       |
|-------|----------------------------|-------|
| 12345 | abcdefghijklmnopqrstuvwxy  | 67890 |
|       | ABCDEFGHIJKLMNOPQRSTUVWXYZ |       |
|       | abcdefghijklmnopqrstuvwxy  |       |
| 12345 | abcdefghijklmnopqrstuvwxy  | 67890 |
|       | ABCDEFGHIJKLMNOPQRSTUVWXYZ |       |

# No. 8A. Book Arrangement C

## Composition Matrices

9 Point No. 8A, 9 Set

### MONOTYPE FACES

The best kind of originality is that which comes after a sound apprenticeship; that which shall prove to be the blending of a firm conception of all useful precedent and the progressive tendencies of an able mind. For, let a man be as able and original as he may, he cannot afford to discard knowledge of what has gone before or what is now going on in his own trade and profession. If the printers of today do not wish to be esteemed arrogant when they term this calling of theirs an art, they must be willing, and show that they are willing, to subject it to such laws as have made its sister arts so free. All those concerned in what are accepted as the fine arts, the learned sciences, and the professions surround themselves with the history, literature, and concrete examples of the work with which they are particularly engaged. Yet it is only in rare instances that such an atmosphere, with its material appurtenances, is to be found in a printing office. *Art does not flourish in the hidden places, nor under restraint, nor in*

12345 abcdefghijklmnopqrstuvwxyz 67890\$

ABCDEFGHIJKLMNOPQRSTUVWXYZ

ABCDEFGHIJKLMNOPQRSTUVWXYZ

12345 abcdefghijklmnopqrstuvwxyz 67890\$

ABCDEFGHIJKLMNOPQRSTUVWXYZ

11 Point No. 8A, 11 Set

### MONOTYPE FACES

The very best kind of originality is that which comes after a thorough apprenticeship; that which shall prove to be the blending of a firm conception of all useful precedent and the progressive tendencies of an able mind. For, let a man be as able and original as he may, he cannot afford to discard knowledge of what has gone before or what is now going on in his own trade and profession. If the printers of today do not wish to be esteemed arrogant when they term this calling of theirs an art, they must be willing, and show that they are willing, to subject it to such laws as have made its sister arts so free. All those concerned in what are accepted as the fine arts, the learned sciences, and professions surround

12345 abcdefghijklmnopqrstuvwxyz 67890\$

ABCDEFGHIJKLMNOPQRSTUVWXYZ

ABCDEFGHIJKLMNOPQRSTUVWXYZ

12345 abcdefghijklmnopqrstuvwxyz 67890\$

ABCDEFGHIJKLMNOPQRSTUVWXYZ

10 Point No. 8A, 10 Set

### MONOTYPE FACES

The best kind of originality is that which comes after a sound apprenticeship; that which shall prove to be the blending of a firm conception of all useful precedent and the progressive tendencies of an able mind. For, let a man be as able and original as he may, he cannot afford to discard knowledge of what has gone before or what is now going on in his own trade and profession. If the printers of today do not wish to be esteemed arrogant when they term this calling of theirs an art, they must be willing, and show that they are willing, to subject it to such laws as have made its sister arts so free. All those who are concerned in what are accepted as the fine arts, the learned sciences, and the professions surround themselves with the history, literature, and concrete examples of the work with which they are particularly

12345 abcdefghijklmnopqrstuvwxyz 67890\$

ABCDEFGHIJKLMNOPQRSTUVWXYZ

ABCDEFGHIJKLMNOPQRSTUVWXYZ

12345 abcdefghijklmnopqrstuvwxyz 67890\$

ABCDEFGHIJKLMNOPQRSTUVWXYZ

12 Point No. 8A, 12 Set

### MONOTYPE FACES

The best kind of originality is that which comes after a sound apprenticeship; that which shall prove to be the blending of a firm conception of all useful precedent and the progressive tendencies of an able mind. For, let any man be as able and original as he may, he cannot afford to discard knowledge of what has gone before or what is now going on in his own trade and profession. If the printers of today do not wish to be esteemed arrogant when they term this calling of theirs an art, they must be willing, and show that they are willing, to subject it to such laws as

1234 abcdefghijklmnopqrstuvwxyz 567\$

ABCDEFGHIJKLMNOPQRSTUVWXYZ

ABCDEFGHIJKLMNOPQRSTUVWXYZ

1234 abcdefghijklmnopqrstuvwxyz 567\$

ABCDEFGHIJKLMNOPQRSTUVWXYZ

# No. 13A. Book Arrangement C

## Composition Matrices

6 Point No. 13A, 8½ Set

### MONOTYPE FACES

The best kind of originality is that which comes after a sound apprenticeship; that which shall prove itself to be the blending of a firm conception of useful precedent and the progressive tendencies of an able mind. For, let a man be as able and original as he may, he cannot afford to discard knowledge of what has gone before or what is now going on in his own trade and profession. If the printers of today do not wish to be esteemed arrogant when they term this calling of theirs an art, they must be willing, and show that they are willing, to subject it to such laws as have made its sister arts so free. All those concerned in what are accepted as the fine arts, the learned sciences and professions surround themselves with the history, literature, and concrete examples of work with which they are particularly engaged. Yet it is only in very rare instances that such an atmosphere, with its material appurtenances, is to be found in the printing office. Art does not flourish in hidden places, nor under restraint, nor in ignorance of what talent and genius have accomplished and are accomplishing throughout the world. For to follow precedent wisely does not mean to imitate slavishly one great exemplar, but to study all the masters faithfully, letting their great achievements sink slowly into the mind in order that we may patiently derive from the richness of our acquired knowledge and organized system an attitude of our own. The sprightly minded young man, who with his first business breath projects the new and startling, inevitably becomes tiresome, and is driven to an early disappearance; while the slower and more solidly endowed student will at least spend as much of his time in avoiding mistakes as in evolving brilliant schemes

12345      abcdefghijklmnopqrstuvwxyz      67890\$  
 ABCDEFGHIJKLMNOPQRSTUVWXYZ  
 ABCDEFGHIJKLMNOPQRSTUVWXYZ  
 12345      abcdefghijklmnopqrstuvwxyz      67890\$  
 ABCDEFGHIJKLMNOPQRSTUVWXYZ

7 Point No. 13A, 9½ Set

### MONOTYPE FACES

The best kind of originality is that which comes after a sound apprenticeship; that which shall prove to be the blending of a firm conception of all useful precedent and the progressive tendencies of an able mind. For, let any man be as able and as original as he may, he cannot afford to discard knowledge of what has gone before or what is now going on in his own trade and profession. If the printers of today do not wish to be esteemed arrogant when they term this calling of theirs an art, they must be willing, and show that they are willing, to subject it to such laws as have made its sister arts so free. All those concerned in what are accepted as the fine arts, the learned sciences and the professions surround themselves with the history, the literature, and concrete examples of the work with which they are particularly engaged. Yet it is only in rare instances that such an atmosphere, with its material appurtenances, is to be found in a printing office. Art does not flourish in hidden places, nor under restraint, nor in ignorance of what talent and genius have accomplished and are now accomplishing throughout the world. For to follow precedent wisely does not mean to imitate slavishly one great exemplar, but to study all masters faithfully, letting their great achievements sink slowly into the mind in order that we may patiently derive from the richness of our acquired

12345      abcdefghijklmnopqrstuvwxyz      67890\$  
 ABCDEFGHIJKLMNOPQRSTUVWXYZ  
 ABCDEFGHIJKLMNOPQRSTUVWXYZ  
 12345      abcdefghijklmnopqrstuvwxyz      67890\$  
 ABCDEFGHIJKLMNOPQRSTUVWXYZ

8 Point No. 13A, 9½ Set

### MONOTYPE FACES

The best kind of originality is that which comes after a sound apprenticeship; that which shall prove to be the blending of a firm conception of all useful precedent and the progressive tendencies of an able mind. For, let a man be as able and original as he may, he cannot afford to discard knowledge of what has gone before or what is now going on in his own trade and profession. If the printers of today do not wish to be esteemed arrogant when they term this calling of theirs an art, they must be willing, and show that they are willing, to subject it to such laws as have made its sister arts so free. All those concerned in what are accepted as the fine arts, the learned sciences and the professions surround themselves with the history, literature, and concrete examples of the work with which they are particularly engaged. Yet it is only in rare instances that such an atmosphere, with its material appurtenances, is to be found in a printing office. Art does not flourish in hidden places, nor under restraint, nor in ignorance of what

12345      abcdefghijklmnopqrstuvwxyz      67890\$  
 ABCDEFGHIJKLMNOPQRSTUVWXYZ  
 ABCDEFGHIJKLMNOPQRSTUVWXYZ  
 12345      abcdefghijklmnopqrstuvwxyz      67890\$  
 ABCDEFGHIJKLMNOPQRSTUVWXYZ

### MONOTYPE FACES

The best kind of originality is that which comes after a sound apprenticeship; that which shall prove to be the blending of a firm conception of all useful precedent and the progressive tendencies of an able mind. For, let a man be as able and original as he may, he cannot afford to discard knowledge of what has gone before or what is now going on in his own trade and profession. If the printers of today do not wish to be esteemed arrogant when they term this calling of theirs an art, they must be willing, and show that they are willing, to subject it to such laws as have made its sister arts so free. All those concerned in what are accepted as the fine arts, the learned sciences and the professions surround themselves with the history, literature, and concrete examples of the work with which they are particularly engaged. Yet it is only in rare instances that such an atmosphere, with its material appurtenances, is to be found in a printing office. Art does not flourish in hidden places, nor under restraint, nor in ignorance of what talent and genius have accomplished and are now accomplishing throughout the world. For to follow precedent wisely does not mean to imitate slavishly one great exemplar, but to study all masters faithfully, letting their great achievements sink slowly

# No. 14A. Book Arrangement C

## Composition Matrices

8 Point No. 14A, 8 Set

### MONOTYPE FACES

The best kind of originality is that which comes after a sound apprenticeship; that which shall prove to be the blending of a firm conception of all useful precedent and the progressive tendencies of an able mind. For, let a man be as able and original as he may, he cannot afford to discard knowledge of what has gone before or what is now going on in his own trade and profession. If the printers of today do not wish to be esteemed arrogant when they term this calling of theirs an art, they must be willing, and show that they are willing, to subject it to such laws as have made its sister arts so free. All those concerned in what are accepted as the fine arts, the learned sciences, and the professions surround themselves with the history, the literature, and concrete examples of the work with which they are particularly engaged. Yet it is only in rare instances that such an atmosphere with its material appurtenances, is to be found in a printing office. Art does not flourish in hidden places, nor under restraint, nor in ignorance of what talent and genius have accomplished and are accomplishing throughout the world. For to follow precedent wisely does not mean to imitate slavishly one great exemplar, but to study all masters faithfully, letting their great achievements sink slowly into the mind in order that we may patiently derive from

12345      abcdefghijklmnopqrstuvwxyz      67890\$  
ABCDEF GHIJKL MNOPQRSTUVWXYZ  
ABCDEF GHIJKL MNOPQRSTUVWXYZ  
12345      abcdefghijklmnopqrstuvwxyz      67890\$  
ABCDEF GHIJKL MNOPQRSTUVWXYZ

12 Point No. 14A, 11 Set

### MONOTYPE FACES

The best kind of originality is that which comes after a sound apprenticeship; that which shall prove to be the blending of a firm conception of all useful precedent and the progressive tendencies of an able mind. For, let a man be as able and original as he may, he cannot afford to discard knowledge of what has gone before or what is now going on in his own trade and profession. If the printers of today do not wish to be esteemed arrogant when they term this calling of theirs an art, they must be willing, and show that they are willing, to subject it to such laws as

12345      abcdefghijklmnopqrstuvwxyz      67890\$  
ABCDEF GHIJKL MNOPQRSTUVWXYZ  
ABCDEF GHIJKL MNOPQRSTUVWXYZ  
12345      abcdefghijklmnopqrstuvwxyz      67890\$  
ABCDEF GHIJKL MNOPQRSTUVWXYZ

12 Point No. 214A, 11 Set

### MONOTYPE FACES

The best kind of originality is that which comes after a sound apprenticeship; that which shall prove to be the blending of a firm conception of all useful precedent and the progressive tendencies of an able mind. For, let a man be as able and original as he may, he cannot afford to discard knowledge of what has gone before or what is now going on in his own trade and profession. If the printers of today do not wish to be esteemed arrogant when they term this calling of theirs an art, they must be willing, and show that they are willing, to subject it to such laws as have made its sister arts so free. All those

12345      abcdefghijklmnopqrstuvwxyz      67890\$  
ABCDEF GHIJKL MNOPQRSTUVWXYZ  
ABCDEF GHIJKL MNOPQRSTUVWXYZ  
12345      abcdefghijklmnopqrstuvwxyz      67890\$  
ABCDEF GHIJKL MNOPQRSTUVWXYZ

### MONOTYPE FACES

The best kind of originality is that which comes after a sound apprenticeship; that which shall prove to be the blending of a firm conception of all useful precedent and the progressive tendencies of an able mind. For, let a man be as able and original as he may, he cannot afford to discard knowledge of what has gone before or what is now going on in his own trade and profession. If the printers of today do not wish to be esteemed arrogant when they term this calling of theirs an art, they must be willing, and show that they are willing, to subject it to such laws as have made its sister arts so free. All those concerned in what are accepted as the fine arts, the learned sciences, and professions surround

# No. 19A. Book Arrangement C

## Composition Matrices

6 Point No. 19A, 7½ Set

### MONOTYPE FACES

The best kind of originality is that which comes after a sound apprenticeship; that which shall prove to be the blending of a firm conception of all useful precedent and the progressive tendencies of an able mind. For, let a man be as able and original as he may, he cannot afford to discard knowledge of what has gone before or what is now going on in his own trade and profession. If the printers of today do not wish to be esteemed arrogant when they term this calling of theirs an art, they must be willing, and show that they are willing, to subject it to such laws as have made its sister arts so free. All those concerned in what are accepted as the fine arts, the learned sciences, and the professions surround themselves with the history, literature, and concrete examples of the work with which they are particularly engaged. Yet it is only in rare instances that such an atmosphere, with its material appurtenances, is to be found in a printing office. Art does not flourish in hidden places, nor under restraint, nor in ignorance of all that talent and genius have accomplished and are now accomplishing throughout the world. For to follow precedent wisely does not mean to imitate slavishly one great exemplar, but to study all masters faithfully, letting their great achievements sink slowly into the mind in order that we may patiently derive from the richness of our acquired knowledge and organized system an attitude of our own. The sprightly minded young man, who with his first business breath projects the new and startling, inevitably becomes very tiresome, and is driven to an early disappearance; while the slower, more solidly endowed student will at least spend as much of

|       |                            |         |
|-------|----------------------------|---------|
| 12345 | abcdefghijklmnopqrstuvwxy  | 67890\$ |
|       | ABCDEFGHIJKLMNQPQRSTUVWXYZ |         |
|       | ABCDEFGHIJKLMNQPQRSTUVWXYZ |         |
| 12345 | abcdefghijklmnopqrstuvwxy  | 67890\$ |
|       | ABCDEFGHIJKLMNQPQRSTUVWXYZ |         |

### MONOTYPE FACES

The best kind of originality is that which comes after a sound apprenticeship; that which shall prove to be the blending of a firm conception of all useful precedent and the progressive tendencies of an able mind. For, let a man be as able and original as he may, he cannot afford to discard knowledge of what has gone before or what is now going on in his own trade and profession. If the printers of today do not wish to be esteemed arrogant when they term this calling of theirs an art, they must be willing, and show that they are willing, to subject it to such laws as have made its sister arts so free. All those concerned in what are accepted as the fine arts, the learned sciences, and the professions surround themselves with the history, literature, and concrete examples of the work with which they are particularly engaged. Yet it is only in rare instances that such an atmosphere, with its material appurtenances, is to be found in a printing office. Art does not flourish in hidden places, nor under restraint, nor in ignorance of all that talent and genius have accomplished and are now accomplishing throughout the world. For to follow precedent wisely does not mean to imitate slavishly one great exemplar, but to study all masters faithfully, letting their great achievements sink slowly into the mind in order that we may patiently derive from the richness of our acquired knowledge and organized system an attitude of our own. The sprightly minded young man, who with his first business breath projects the new and startling, inevitably becomes very tiresome, and is driven to an early disappearance; while the slower, more solidly endowed student will at least spend as much of his time in avoiding mistakes as in evolving brilliant schemes wherewith to dazzle his contemporaries. The best kind of originality is that which comes after a sound apprenticeship; that which shall prove to be the blending of a firm conception of all useful precedent and the progressive tendencies of an able mind. For, let a man be as able and original as he may, he cannot afford to discard knowledge of what has gone before or what is now going on in his own trade and profession. If the printers of today do not wish to

8 Point No. 19A, 8½ Set

### MONOTYPE FACES

The best kind of originality is that which comes after a sound apprenticeship; that which shall prove to be the blending of a firm conception of all useful precedent and the progressive tendencies of an able mind. For, let a man be as able and original as he may, he cannot afford to discard knowledge of what has gone before or what is now going on in his own trade and profession. If the printers of today do not wish to be esteemed arrogant when they term this calling of theirs an art, they must be willing, and show that they are willing, to subject it to such laws as have made its sister arts so free. All those concerned in what are accepted as the fine arts, learned sciences, and professions surround themselves with the history, the literature, and concrete examples of the work with which they are particularly engaged. Yet it is only in very rare instances that such an atmosphere, with its material appurtenances, is to be found in a printing office. Art does not flourish in hidden places, nor under restraint, nor in ignorance of what talent and genius have accomplished and are now accomplishing throughout the world. For to follow all precedent wisely does not mean to imitate

|       |                            |         |
|-------|----------------------------|---------|
| 12345 | abcdefghijklmnopqrstuvwxy  | 67890\$ |
|       | ABCDEFGHIJKLMNQPQRSTUVWXYZ |         |
|       | ABCDEFGHIJKLMNQPQRSTUVWXYZ |         |
| 12345 | abcdefghijklmnopqrstuvwxy  | 67890\$ |
|       | ABCDEFGHIJKLMNQPQRSTUVWXYZ |         |

### MONOTYPE FACES

The best kind of originality is that which comes after a sound apprenticeship; that which shall prove to be the blending of a firm conception of all useful precedent and the progressive tendencies of an able mind. For, let a man be as able and original as he may, he cannot afford to discard knowledge of what has gone before or what is now going on in his own trade and profession. If the printers of today do not wish to be esteemed arrogant when they term this calling of theirs an art, they must be willing, and show that they are willing, to subject it to such laws as have made its sister arts so free. All those concerned in what are accepted as the fine arts, learned sciences, and professions surround themselves with the history, the literature, and concrete examples of the work with which they are particularly engaged. Yet it is only in very rare instances that such an atmosphere, with its material appurtenances, is to be found in a printing office. Art does not flourish in hidden places, nor under restraint, nor in ignorance of what talent and genius have accomplished and are now accomplishing throughout the world. For to follow all precedent wisely does not mean to imitate slavishly one great exemplar, but to study all masters faithfully, letting their great achievements sink slowly into the mind in order that we may patiently derive from the richness of our acquired knowledge and organized system an attitude of our own. The sprightly minded young man

# No. 20A. Book Arrangement C

## Composition Matrices

6 Point No. 20A, 7 Set

### MONOTYPE FACES

The best kind of originality is that which comes after a sound apprenticeship; that which shall prove itself to be the blending of a firm conception of useful precedent and the progressive tendencies of an able mind. For, let a man be as able and original as he may, he cannot afford to discard knowledge of what has gone before or what is now going on in his own trade and profession. If the printers of today do not wish to be esteemed arrogant when they term this calling of theirs an art, they must be willing, and show that they are willing, to subject it to such laws as have made its sister arts so free. All those concerned in what are accepted as the fine arts, the learned sciences, and professions surround themselves with the history, literature, and concrete examples of the work with which they are particularly engaged. Yet it is only in very rare instances that such an atmosphere, with its material appurtenances, is to be found in the printing office. Art does not flourish in hidden places, nor under restraint, nor in ignorance of what talent and genius have accomplished and are accomplishing throughout the world. For to follow precedent wisely does not mean to imitate slavishly one great exemplar, but to study all masters faithfully, letting their great achievements sink slowly into the mind in order that we may patiently derive from the richness of our acquired knowledge and organized system an attitude of our own. The sprightly minded young man, who with his first business breath projects the new and startling, inevitably becomes tiresome, and is driven to an early disappearance; while the slower and more solidly endowed student will at least spend as much of his time in avoiding mistakes as in evolving brilliant schemes wherewith to dazzle his contemporaries. The best kind of originality is that which comes after a sound apprenticeship; that which shall prove itself to be the blending of a firm conception of all useful precedent and the progressive tendencies of an able mind. For, let a man be as able and original as he

12345      abcdefghijklmnopqrstuvwxyz      67890\$  
 ABCDEFGHIJKLMNOPQRSTUVWXYZ  
 ABCDEFGHIJKLMNOPQRSTUVWXYZ  
 12345      abcdefghijklmnopqrstuvwxyz      67890\$  
 ABCDEFGHIJKLMNOPQRSTUVWXYZ

9 Point No. 20A, 9½ Set

### MONOTYPE FACES

The best kind of originality is that which comes after a sound apprenticeship; that which shall prove to be the blending of a firm conception of all useful precedent and the progressive tendencies of an able mind. For, let a man be as able and original as he may, he cannot afford to discard knowledge of what has gone before or what is now going on in his own trade and profession. If the printers of today do not wish to be esteemed arrogant when they term this calling of theirs an art, they must be willing, and show that they are willing, to subject it to such laws as have made its sister arts so free. All those concerned in what are accepted as the fine arts, the learned sciences, and the professions surround themselves with the history, the literature, and concrete examples of the work with which they are particularly engaged. Yet it is only in very rare instances that such an atmosphere, with its material appurtenances, is to be found in a printing office. Art does not flourish in hidden places,

12345      abcdefghijklmnopqrstuvwxyz      67890\$  
 ABCDEFGHIJKLMNOPQRSTUVWXYZ  
 ABCDEFGHIJKLMNOPQRSTUVWXYZ  
 12345      abcdefghijklmnopqrstuvwxyz      67890\$  
 ABCDEFGHIJKLMNOPQRSTUVWXYZ

8 Point No. 20A, 8½ Set

### MONOTYPE FACES

The best kind of originality is that which comes after a sound apprenticeship; that which shall prove to be the blending of a firm conception of all useful precedent and the progressive tendencies of an able mind. For, let a man be as able and original as he may, he cannot afford to discard knowledge of what has gone before or what is now going on in his own trade and profession. If the printers of today do not wish to be esteemed arrogant when they term this calling of theirs an art, they must be willing, and show that they are willing, to subject it to such laws as have made its sister arts so free. All those concerned in what are accepted as the fine arts, learned sciences, and professions surround themselves with the history, the literature, and concrete examples of the work with which they are particularly engaged. Yet it is only in very rare instances that such an atmosphere, with its material appurtenances, is to be found in a printing office. Art does not flourish in hidden places, nor under restraint, nor in ignorance of what talent and genius have accomplished and are now accomplishing throughout the world. For to follow all precedent wisely does not mean to imitate slavishly one great exemplar, but to study all masters faith-

12345      abcdefghijklmnopqrstuvwxyz      67890\$  
 ABCDEFGHIJKLMNOPQRSTUVWXYZ  
 ABCDEFGHIJKLMNOPQRSTUVWXYZ  
 12345      abcdefghijklmnopqrstuvwxyz      67890\$  
 ABCDEFGHIJKLMNOPQRSTUVWXYZ

10 Point No. 20A, 10½ Set

### MONOTYPE FACES

The best kind of originality is that which comes after a sound apprenticeship; that which shall prove to be the blending of a firm conception of all useful precedent and the progressive tendencies of an able mind. For, let a man be as able and original as he may, he cannot afford to discard knowledge of what has gone before or what is now going on in his own trade and profession. If the printers of today do not wish to be esteemed arrogant when they term this calling of theirs an art, they must be willing, and show that they are willing, to subject it to such laws as have made its sister arts so free. All those concerned in what are accepted as the fine arts, the learned sciences, and the professions surround themselves with the history, the literature, and concrete examples of the work with which they are particularly engaged. Yet it

12345      abcdefghijklmnopqrstuvwxyz      67890\$  
 ABCDEFGHIJKLMNOPQRSTUVWXYZ  
 ABCDEFGHIJKLMNOPQRSTUVWXYZ  
 12345      abcdefghijklmnopqrstuvwxyz      67890\$  
 ABCDEFGHIJKLMNOPQRSTUVWXYZ

# No. 20A. Book Arrangement C

## Composition Matrices

11 Point No. 20A, 11 Set

### MONOTYPE FACES

The very best kind of originality is that which comes after a thorough apprenticeship; that which shall prove to be the blending of a firm conception of all useful precedent and the progressive tendencies of an able mind. For, let a man be as able and original as he may, he cannot afford to discard knowledge of what has gone before or what is now going on in his own trade and profession. If the printers of today do not wish to be esteemed arrogant when they term this calling of theirs an art, they must be willing, and show that they are willing, to subject it to such laws as have made its sister arts so free. All those *concerned in what are accepted as the fine arts, the learned sciences, and professions surround*

12345 abcdefghijklmnopqrstuvwxyz 67890\$

ABCDEFGHIJKLMNOPQRSTUVWXYZ

ABCDEFGHIJKLMNOPQRSTUVWXYZ

12345 abcdefghijklmnopqrstuvwxyz 67890\$

ABCDEFGHIJKLMNOPQRSTUVWXYZ

### MONOTYPE FACES

The very best kind of originality is that which comes after a thorough apprenticeship; that which shall prove to be the blending of a firm conception of all useful precedent and the progressive tendencies of an able mind. For, let a man be as able and original as he may, he cannot afford to discard knowledge of what has gone before or what is now going on in his own trade and profession. If the printers of today do not wish to be esteemed arrogant when they term this calling of theirs an art, they must be willing, and show that they are willing, to subject it to such laws as have made its sister arts so free. All those concerned in what are accepted as the fine arts, the learned sciences, and professions surround *themselves with the history, literature, and concrete examples of work with which they are*

12 Point No. 20A, 12 Set

### MONOTYPE FACES

The best kind of originality is that which comes after a sound apprenticeship; that which shall prove to be the blending of a firm conception of all useful precedent and the progressive tendencies of an able mind. For, let any man be as able and original as he may, he cannot afford to discard knowledge of what has gone before or what is now going on in his own trade and profession. If the printers of *today do not wish to be esteemed arrogant when they term this calling of theirs an art,*

12345 abcdefghijklmnopqrstuvwxyz 67890\$

ABCDEFGHIJKLMNOPQRSTUVWXYZ

ABCDEFGHIJKLMNOPQRSTUVWXYZ

12345 abcdefghijklmnopqrstuvwxyz 67890\$

ABCDEFGHIJKLMNOPQRSTUVWXYZ

### MONOTYPE FACES

The best kind of originality is that which comes after a sound apprenticeship; that which shall prove to be the blending of a firm conception of all useful precedent and the progressive tendencies of an able mind. For, let any man be as able and original as he may, he cannot afford to discard knowledge of what has gone before or what is now going on in his own trade and profession. If the printers of today do not wish to be esteemed arrogant when they term this calling of theirs an art, they must be willing, and show that they are willing, to subject it to such laws

14 Point No. 20

**ABSOLUTE HEIGHT TO PAPER**

Each Type is Finished Absolutely before it Leaves the Mold. It is not "Near Perfect," but Ready to Use

\$1234567890

18 Point No. 20

**ELEVEN GOVERNMENTS**

Throughout the World use the Monotype on all Classes of Plain and Intricate Work

\$1234567890

24 Point No. 20

**INTRICATE WORK**

No Job is too Intricate for the "One-type-at-a-time" Machine

\$1234567890

30 Point No. 20

**STANDING MATTER**

Expense Reduced to the Bare Cost of the Monotype Metal

\$1234567890

36 Point No. 20

**THE CHEAPEST**

To Buy, To Maintain, To Run

\$1234567890



14 Point No. 201

**NEWSPAPER AND JOB OFFICES**  
*Composing Matter Always Considered as Strictly Handwork, Saving  
Money and Time with the Monotype*  
\$1234567890

18 Point No. 201

**THE MONOTYPE SCHOOL**  
*Furnishes Free Instruction for Caster and Keyboard to  
Ambitious Compositors*  
\$1234567890

24 Point No. 201

**CONTINUOUS LINES**  
*Of Sixty Picas; a Record Unequaled by  
Any Other Machine*  
\$1234567890

30 Point No. 201

**A GOOD MACHINE**  
*Must Cast Separate Type. It is  
the Only and Profitable Way*  
\$1234567890

36 Point No. 201

**ALL ADVERTISERS**  
*Prefer Monotype Composition*  
\$1234567890

# No. 34A. Book Arrangement C

## Composition Matrices

6 Point No. 34A, 6½ Set

### MONOTYPE FACES

The best kind of originality is that which comes after a sound apprenticeship; that which shall prove to be the blending of a firm conception of all useful precedent and of the progressive tendencies of an able mind. For, let a man be as able and original as he may, he cannot afford to discard knowledge of what has gone before or what is now going on in his own trade and profession. If the printers of today do not wish to be esteemed arrogant when they term this calling of theirs an art, they must be willing, and show that they are willing, to subject it to such laws as have made its sister arts so free. All those concerned in what are accepted as the fine arts, the learned sciences, and the professions surround themselves with the history, literature, and concrete examples of the work with which they are particularly engaged. Yet it is only in rare instances that such an atmosphere, with its material appurtenances, is to be found in a printing office. Art does not flourish in hidden places, nor under restraint, nor in ignorance of what talent and genius have accomplished and are accomplishing throughout the world. For to follow precedent wisely does not mean to imitate slavishly one great exemplar, but to study all masters faithfully, letting their great achievements sink slowly into the mind in order that we may patiently derive from the richness of our acquired knowledge and organized system an attitude of our own. The sprightly minded young man, who with his first business breath projects the new and startling, inevitably becomes tiresome, and is driven to an early disappearance; while the slower, more solidly endowed student will at least spend as much of his time in avoiding mistakes as in evolving brilliant schemes wherewith to dazzle his contemporaries. The best kind of originality is that which comes after a sound apprenticeship; that which shall prove to be the blending of a firm conception of all useful precedent and the progressive tendencies of an able mind. For, let any man be as able and original as he may, he cannot well afford to discard knowledge of what has gone before or what is now going on in his own trade and profession. If the printers of today do not wish to be esteemed arrogant when

12345            abcdefghijklmnopqrstuvwxyz            67890\$  
 ABCDEFGHIJKLMNOPQRSTUVWXYZ  
 ABCDEFGHIJKLMNOPQRSTUVWXYZ  
 12345            abcdefghijklmnopqrstuvwxyz            67890\$  
 ABCDEFGHIJKLMNOPQRSTUVWXYZ

9 Point No. 34A, 8½ Set

### MONOTYPE FACES

The best kind of originality is that which comes after a sound apprenticeship; that which shall prove to be the blending of a firm conception of all useful precedent and the progressive tendencies of an able mind. For, let a man be as able and original as he may, he cannot afford to discard knowledge of what has gone before or what is now going on in his own trade and profession. If the printers of today do not wish to be esteemed arrogant when they term this calling of theirs an art, they must be willing, and show that they are willing, to subject it to such laws as have made its sister arts so free. All those concerned in what are accepted as the fine arts, the learned sciences, and the professions surround themselves with the history, the literature, and concrete examples of the work with which they are particularly engaged. Yet it is only in very rare instances that such an atmosphere, with its material appurtenances, is to be found in a printing office. Art does not flourish in hidden places, nor under restraint, nor in ignorance of what talent and genius have accomplished and are accomplishing throughout the world. For to follow

12345            abcdefghijklmnopqrstuvwxyz            67890\$  
 ABCDEFGHIJKLMNOPQRSTUVWXYZ  
 ABCDEFGHIJKLMNOPQRSTUVWXYZ  
 12345            abcdefghijklmnopqrstuvwxyz            67890\$  
 ABCDEFGHIJKLMNOPQRSTUVWXYZ

8 Point No. 34A, 8 Set

### MONOTYPE FACES

The best kind of originality is that which comes after a sound apprenticeship; that which shall prove to be the blending of a firm conception of all useful precedent and the progressive tendencies of an able mind. For, let a man be as able and original as he may, he cannot afford to discard knowledge of what has gone before or what is now going on in his own trade and profession. If the printers of today do not wish to be esteemed arrogant when they term this calling of theirs an art, they must be willing, and show that they are willing, to subject it to such laws as have made its sister arts so free. All those concerned in what are accepted as the fine arts, the learned sciences, and the professions surround themselves with the history, the literature, and concrete examples of the work with which they are more particularly engaged. Yet it is only in rare instances that such an atmosphere, with its material appurtenances, is to be found in a printing office. Art does not flourish in hidden places, nor under restraint, nor in ignorance of what talent and genius have accomplished and are accomplishing throughout the world. For to follow precedent wisely does not mean to imitate slavishly one great exemplar, but to study all masters faithfully, letting their great achievements sink slowly into the mind in order that we may

12345            abcdefghijklmnopqrstuvwxyz            67890\$  
 ABCDEFGHIJKLMNOPQRSTUVWXYZ  
 ABCDEFGHIJKLMNOPQRSTUVWXYZ  
 12345            abcdefghijklmnopqrstuvwxyz            67890\$  
 ABCDEFGHIJKLMNOPQRSTUVWXYZ

10 Point No. 34A, 9½ Set

### MONOTYPE FACES

The best kind of originality is that which comes after a sound apprenticeship; that which shall prove to be the blending of a firm conception of all useful precedent and the progressive tendencies of an able mind. For, let a man be as able and original as he may, he cannot afford to discard knowledge of what has gone before or what is now going on in his own trade and profession. If the printers of today do not wish to be esteemed too arrogant when they term this calling of theirs an art, they must be willing, and show that they are willing, to subject it to such laws as have made its sister arts so free. All those concerned in what are accepted as the fine arts, the learned sciences, and professions surround themselves with the history, literature, and concrete examples of the work with which they are particularly engaged. Yet it is only in rare instances that such an atmosphere, with all its material appurtenances, is to be found in a

12345            abcdefghijklmnopqrstuvwxyz            67890\$  
 ABCDEFGHIJKLMNOPQRSTUVWXYZ  
 ABCDEFGHIJKLMNOPQRSTUVWXYZ  
 12345            abcdefghijklmnopqrstuvwxyz            67890\$  
 ABCDEFGHIJKLMNOPQRSTUVWXYZ

# No. 34A. Book Arrangement C

## Composition Matrices

11 Point No. 34A, 10 Set

### MONOTYPE FACES

The best kind of originality is that which comes after a sound apprenticeship; that which shall prove to be the blending of a firm conception of all useful precedent and the progressive tendencies of an able mind. For, let a man be as able and original as he may, he cannot afford to discard knowledge of what has gone before or what is now going on in his own trade and profession. If the printers of today do not wish to be esteemed arrogant when they term this calling of theirs an art, they must be willing, and show that they are willing, to subject it to such laws as have made its sister arts so free. All those who are concerned in what are accepted as the fine arts, the learned sciences, and the professions surround *themselves with the history, literature, and concrete examples of the work with which they are particularly*

12345 abcdefghijklmnopqrstuvwxyz 67890\$

ABCDEFGHIJKLMNOPQRSTUVWXYZ

ABCDEFGHIJKLMNOPQRSTUVWXYZ

12345 abcdefghijklmnopqrstuvwxyz 67890\$

ABCDEFGHIJKLMNOPQRSTUVWXYZ

12 Point No. 34A, 11 Set

### MONOTYPE FACES

The very best kind of originality is that which comes after a thorough apprenticeship; that which shall prove to be the blending of a firm conception of all useful precedent and the progressive tendencies of an able mind. For, let a man be as able and original as he may, he cannot afford to discard knowledge of what has gone before or what is now going on in his own trade and profession. If the printers of today do not wish to be esteemed arrogant when they term this calling of theirs an art, they must be willing, and show that they are willing, to subject it to such laws as *have made its sister arts so free. All those concerned in what are accepted as the fine arts, the*

12345 abcdefghijklmnopqrstuvwxyz 67890\$

ABCDEFGHIJKLMNOPQRSTUVWXYZ

ABCDEFGHIJKLMNOPQRSTUVWXYZ

12345 abcdefghijklmnopqrstuvwxyz 67890\$

ABCDEFGHIJKLMNOPQRSTUVWXYZ

# No. 35A. Book Arrangement C

## Composition Matrices

10 Point No. 35A, 10 Set

### MONOTYPE FACES

The best kind of originality is that which comes after a sound apprenticeship; that which shall prove to be the blending of a firm conception of all useful precedent and the progressive tendencies of an able mind. For, let a man be as able and original as he may, he cannot afford to discard knowledge of what has gone before or what is now going on in his own trade and profession. If the printers of today do not wish to be esteemed arrogant when they term this calling of theirs an art, they must be willing, and show that they are willing, to subject it to such laws as have made its sister arts so free. All those who are concerned in what are accepted as the fine arts, the learned sciences, and the professions surround themselves with the history, the literature, and *concrete examples of the work with which they may be particularly engaged. Yet it is only in very rare*

### MONOTYPE FACES

The best kind of originality is that which comes after a sound apprenticeship; that which shall prove to be the blending of a firm conception of all useful precedent and the progressive tendencies of an able mind. For, let a man be as able and original as he may, he cannot afford to discard knowledge of what has gone before or what is now going on in his own trade and profession. If the printers of today do not wish to be esteemed arrogant when they term this calling of theirs an art, they must be willing, and show that they are willing, to subject it to such laws as have made its sister arts so free. All those who are concerned in what are accepted as the fine arts, the learned sciences, and the professions surround themselves with the history, the literature, and concrete examples of the work with which they are particularly engaged. Yet it is only in very rare instances that such an atmosphere, with its *material appurtenances, is to be found in the printing office. Art does not flourish in hidden places, nor*

12345 abcdefghijklmnopqrstuvwxyz 67890\$

ABCDEFGHIJKLMN OPQRSTUVWXYZ

ABCDEFGHIJKLMN OPQRSTUVWXYZ

12345 abcdefghijklmnopqrstuvwxyz 67890\$

ABCDEFGHIJKLMN OPQRSTUVWXYZ

# No. 36A. Book Arrangement C

## Composition Matrices

6 Point No. 36A, 6½ Set

### MONOTYPE FACES

The best kind of originality is that which comes after a sound apprenticeship; that which shall prove to be the blending of a firm conception of all useful precedent and the progressive tendencies of an able mind. For, let a man be as able and original as he may, he cannot afford to discard knowledge of what has gone before or what is now going on in his own trade and profession. If the printers of today do not wish to be esteemed arrogant when they term this calling of theirs an art, they must be willing, and show that they are willing, to subject it to such laws as have made its sister arts so free. All those concerned in what are accepted as the fine arts, the learned sciences, and the professions surround themselves with the history, literature, and concrete examples of the work with which they are particularly engaged. Yet it is only in rare instances that such an atmosphere, with its material appurtenances, is to be found in a printing office. Art does not flourish in hidden places, nor under restraint, nor in ignorance of what talent and genius have accomplished and are accomplishing throughout the world. For to follow all precedent wisely does not mean to imitate slavishly one great exemplar, but to study all masters faithfully, letting their great achievements sink slowly into the mind in order that we may patiently derive from the richness of our acquired knowledge and organized system an attitude of our own. The sprightly minded young man, who with his first business breath projects the new and startling, inevitably becomes tiresome, and is driven to an early disappearance; while the slower, more solidly endowed student will at least spend as much of his time in avoiding mistakes as in evolving brilliant schemes wherewith to dazzle his contemporaries. The best kind of originality is that which comes after a sound apprenticeship; that which shall prove to be the blending of a firm conception of all useful precedent and the progressive tendencies of an able mind. For, let any man be as able and original as he may, he cannot well afford to discard knowledge of what has gone before or is now going on in his own trade and profession. If the printers of today do not wish to be esteemed arrogant when they

12345      abcdefghijklmnopqrstuvwxyz      67890\$  
**ABCDEFGHIJKLMNOPQRSTUVWXYZ**  
 abcdefghijklmnopqrstuvwxyz  
 12345      abcdefghijklmnopqrstuvwxyz      67890\$  
**ABCDEFGHIJKLMNOPQRSTUVWXYZ**

8 Point No. 36A, 8 Set

### MONOTYPE FACES

The best kind of originality is that which comes after a sound apprenticeship; that which shall prove to be the blending of a firm conception of all useful precedent and the progressive tendencies of an able mind. For, let a man be as able and original as he may, he cannot afford to discard knowledge of what has gone before or what is now going on in his own trade and profession. If the printers of today do not wish to be esteemed arrogant when they term this calling of theirs an art, they must be willing, and show that they are willing, to subject it to such laws as have made its sister arts so free. All those concerned in what are accepted as the fine arts, the learned sciences, and the professions surround themselves with the history, literature, and the concrete examples of the work with which they are particularly engaged. Yet it is only in rare instances that such an atmosphere, with its material appurtenances, is to be found in a printing office. Art does not flourish in hidden places, nor under restraint, nor in ignorance of what talent and genius have accomplished and are accomplishing throughout the world. For to follow precedent wisely does not mean to imitate slavishly one great exemplar, but to study all masters faithfully, letting their great achievements sink slowly into the mind in order that we may patiently derive from

12345      abcdefghijklmnopqrstuvwxyz      67890\$  
**ABCDEFGHIJKLMNOPQRSTUVWXYZ**  
 abcdefghijklmnopqrstuvwxyz  
 12345      abcdefghijklmnopqrstuvwxyz      67890\$  
**ABCDEFGHIJKLMNOPQRSTUVWXYZ**

9 Point No. 36A, 9 Set

### MONOTYPE FACES

The best kind of originality is that which comes after a sound apprenticeship; that which shall prove to be the blending of a firm conception of all useful precedent and the progressive tendencies of an able mind. For, let a man be as able and original as he may, he cannot afford to discard knowledge of what has gone before or what is now going on in his own trade and profession. If the printers of today do not wish to be esteemed arrogant when they term this calling of theirs an art, they must be willing, and show that they are willing, to subject it to such laws as have made its sister arts so free. All those concerned in what are accepted as the fine arts, the learned sciences, and the professions surround themselves with the history, literature, and concrete examples of the work with which they are particularly engaged. Yet it is only in rare instances that such an atmosphere, with its material appurtenances, is to be found in a printing office. Art does not flourish in the hidden places, nor under restraint, nor in ignorance of what talent and genius have accomplished and

12345      abcdefghijklmnopqrstuvwxyz      67890\$  
**ABCDEFGHIJKLMNOPQRSTUVWXYZ**  
 abcdefghijklmnopqrstuvwxyz  
 12345      abcdefghijklmnopqrstuvwxyz      67890\$  
**ABCDEFGHIJKLMNOPQRSTUVWXYZ**

10 Point No. 36A, 10 Set

### MONOTYPE FACES

The best kind of originality is that which comes after a sound apprenticeship; that which shall prove to be the blending of a firm conception of all useful precedent and the progressive tendencies of an able mind. For, let a man be as able and original as he may, he cannot afford to discard knowledge of what has gone before or what is now going on in his own trade and profession. If the printers of today do not wish to be esteemed arrogant when they term this calling of theirs an art, they must be willing, and show that they are willing, to subject it to such laws as have made its sister arts so free. All those who are concerned in what are accepted as the fine arts, the learned sciences, and the professions surround themselves with the history, the literature, and concrete examples of the work with which they are particularly engaged. Yet it is only in very rare

12345      abcdefghijklmnopqrstuvwxyz      67890\$  
**ABCDEFGHIJKLMNOPQRSTUVWXYZ**  
 abcdefghijklmnopqrstuvwxyz  
 12345      abcdefghijklmnopqrstuvwxyz      67890\$  
**ABCDEFGHIJKLMNOPQRSTUVWXYZ**

# No. 36A. Book Arrangement C

## Composition Matrices

11 Point No. 36A, 11 Set

### MONOTYPE FACES

The very best kind of originality is that which comes after a thorough apprenticeship; that which shall prove to be the blending of a firm conception of all useful precedent and the progressive tendencies of an able mind. For, let a man be as able and original as he may, he cannot afford to discard knowledge of what has gone before or what is now going on in his own trade and profession. If the printers of today do not wish to be esteemed arrogant when they term this calling of theirs an art, they must be willing, and show that they are willing, to subject it to such laws as have made its sister arts so free. All those concerned in what are accepted as the fine arts, the learned sciences, and professions surround themselves with the history, literature, and

12345 abcdefghijklmnopqrstuvwxyz 6789\$

ABCDEFGHIJKLMNPOQRSTUVWXYZ

ABCDEFGHIJKLMNPOQRSTUVWXYZ

12345 abcdefghijklmnopqrstuvwxyz 67890\$

ABCDEFGHIJKLMNPOQRSTUVWXYZ

12 Point No. 36A, 12 Set

### MONOTYPE FACES

The best kind of originality is that which comes after a sound apprenticeship; that which shall prove to be the blending of a firm conception of all useful precedent and the progressive tendencies of an able mind. For, let any man be as able and original as he may, he cannot afford to discard knowledge of what has gone before or what is now going on in his own trade and profession. If the printers of today do not wish to be esteemed arrogant when they term this calling of theirs an art, they must be willing, and show *that they are willing, to subject it to such laws as have made its sister arts so free.*

1234 abcdefghijklmnopqrstuvwxyz 567\$

ABCDEFGHIJKLMNPOQRSTUVWXYZ

ABCDEFGHIJKLMNPOQRSTUVWXYZ

1234 abcdefghijklmnopqrstuvwxyz 567\$

ABCDEFGHIJKLMNPOQRSTUVWXYZ

14 Point No. 36

**ALL MATTER IS STRAIGHT MATTER**  
Tariff, Tabular and Intricate Catalogue Composition Handled like  
Straight Matter on the Monotype  
\$1234567890

18 Point No. 36

**GET A TYPE CASTER**  
Convert it into a Composing Machine for Casting all  
Kinds of Justified Ready-to-print Matter  
\$1234567890

24 Point No. 36

**THE ONLY MACHINE**  
Having a Complete and Varied Assortment  
of its own Matrices  
\$1234567890

30 Point No. 36

**A MATRIX LIBRARY**  
All Faces Leased to Customers, just  
like a Circulating Library  
\$1234567890

36 Point No. 36

**BUY A MACHINE**  
With a Repeat-order Record  
\$1234567890

14 Point No. 361

**PROGRESSIVE PUBLISHERS**

*Say our Type Caster is one of the best Advertising Solicitors they ever Employed for their Daily and Sunday Papers*

*\$1234567890*

18 Point No. 361

**IT SATISFIES ADVERTISERS**

*Monotype Composition is a Business Puller for the Advertising Department*

*\$1234567890*

24 Point No. 361

**ADVERTISING COSTS**

*Reduced and Advertisers Pleased with Clean Monotype Work*

*\$1234567890*

30 Point No. 361

**MAKING NEW TYPE**

*For Every Use in a Newspaper Office with the Monotype*

*\$1234567890*

36 Point No. 361

**MONOTYPE TYPE**

*Makes a Smart Newspaper*

*\$1234567890*



# No. 120A. Book Arrangement C

## Composition Matrices

6 Point No. 120A, 7 Set

### MONOTYPE FACES

The best kind of originality is that which comes after a sound apprenticeship; that which shall prove itself to be the blending of a firm conception of useful precedent and the progressive tendencies of an able mind. For, let a man be as able and original as he may, he cannot afford to discard knowledge of what has gone before or what is now going on in his own trade and profession. If the printers of today do not wish to be esteemed arrogant when they term this calling of theirs an art, they must be willing, and show that they are willing, to subject it to such laws as have made its sister arts so free. All those concerned in what are accepted as the fine arts, the learned sciences, and professions surround themselves with the history, literature, and concrete examples of the work with which they are particularly engaged. Yet it is only in very rare instances that such an atmosphere, with its material appurtenances, is to be found in the printing office. Art does not flourish in hidden places nor under restraint, nor in ignorance of what talent and genius have accomplished and are accomplishing throughout the world. For to follow precedent wisely does not mean to imitate slavishly one great exemplar, but to study all masters faithfully, letting their great achievements sink slowly into the mind in order that we may patiently derive from the richness of our acquired knowledge and organized system an attitude of our own. The sprightly minded young man, who with his first business breath projects the new and startling, inevitably becomes tiresome, and is driven to an early disappearance; while the slower, more solidly endowed student will at least spend as much of his time in avoiding mistakes as in evolving brilliant schemes wherewith to dazzle his contemporaries. The best kind of originality is that which comes after a sound apprenticeship; that which shall prove itself to be the blending of a firm conception of all useful precedent and the progressive tendencies of an able mind. For, let any man be as able and original as

### MONOTYPE FACES

The best kind of originality is that which comes after a sound apprenticeship; that which shall prove itself to be the blending of a firm conception of useful precedent and the progressive tendencies of an able mind. For, let a man be as able and original as he may, he cannot afford to discard knowledge of what has gone before or what is now going on in his own trade and profession. If the printers of today do not wish to be esteemed arrogant when they term this calling of theirs an art, they must be willing, and show that they are willing, to subject it to such laws as have made its sister arts so free. All those concerned in what are accepted as the fine arts, the learned sciences, and professions surround themselves with the history, literature, and concrete examples of the work with which they are particularly engaged. Yet it is only in very rare instances that such an atmosphere, with its material appurtenances, is to be found in the printing office. Art does not flourish in hidden places nor under restraint, nor in ignorance of what talent and genius have accomplished and are accomplishing throughout the world. For to follow precedent wisely does not mean to imitate slavishly one great exemplar, but to study all masters faithfully, letting their great achievements sink slowly into the mind in order that we may patiently derive from the richness of our acquired knowledge and organized system an attitude of our own. The sprightly minded young man, who with his first business breath projects the new and startling, inevitably becomes tiresome, and is driven to an early disappearance; while the slower, more solidly endowed student will at least spend as much of his time in avoiding mistakes as in evolving brilliant schemes wherewith to dazzle his contemporaries. The best kind of originality is that which comes after a sound apprenticeship; that which shall prove itself to be the blending of a firm conception of all useful precedent and the progressive tendencies of an able mind. For, let any man be as able and original as he may, he cannot well afford to discard knowledge of what has gone before or what is now going on in his own trade and profession. If the printers of today do not wish to be esteemed arrogant when they term this calling of theirs an art, they must be willing, and show that they are willing, to subject it to such laws as have made its sister arts so free. All those concerned in what are accepted as the fine arts, the learned sciences, and professions surround themselves with the history, literature, and concrete examples of the work with which they are particularly engaged. Yet it is only in very rare instances that such an atmosphere, with its material appurtenances, is to be found in the printing

|       |                                |       |
|-------|--------------------------------|-------|
| 12345 | abcdefgijklmnopqrstuvwxyz      | 67890 |
|       | ABCDEF GHIJ KLMNOP QRSTUV WXYZ |       |
|       | ABCDEF GHIJ KLMNOP QRSTUV WXYZ |       |
| 12345 | abcdefgijklmnopqrstuvwxyz      | 67890 |
|       | ABCDEF GHIJ KLMNOP QRSTUV WXYZ |       |

# No. 150A. Book Arrangement C

## Composition Matrices

6 Point No. 150A, 7½ Set

### MONOTYPE FACES

The best kind of originality is that which comes after a sound apprenticeship; that which shall prove to be the blending of a firm conception of all useful precedent and the progressive tendencies of an able mind. For, let a man be as able and original as he may, he cannot afford to discard knowledge of what has gone before or what is now going on in his own trade and profession. If the printers of today do not wish to be esteemed arrogant when they term this calling of theirs an art, they must be willing, and show that they are willing, to subject it to such laws as have made its sister arts so free. All those concerned in what are accepted as the fine arts, the learned sciences, and the professions surround themselves with the history, literature, and concrete examples of the work with which they are particularly engaged. Yet it is only in rare instances that such an atmosphere, with its material appurtenances, is to be found in a printing office. Art does not flourish in hidden places, nor under restraint, nor in ignorance of all that talent and genius have accomplished and are now accomplishing throughout the world. For to follow precedent wisely does not mean to imitate slavishly one great exemplar, but to study all masters faithfully, letting their great achievements sink slowly into the mind in order that we may patiently derive from the richness of our acquired knowledge and organized system an attitude of our own. The sprightly minded young man, who with his first business breath projects the new and startling, inevitably becomes very tiresome, and is driven to an early disappearance; while the slower, more solidly endowed student will at least spend as much of his time in avoiding mistakes as in evolving brilliant schemes wherewith to dazzle his contemporaries. The best kind of originality is that which comes after a sound apprenticeship; that which shall prove to be the blending of a firm conception of all useful pre-

12345 abcdefghijklmnopqrstuvwxyz 67890\$

ABCDEFGHIJKLMN OPQRSTUVWXYZ

ABCDEFGHIJKLMN OPQRSTUVWXYZ

12345 abcdefghijklmnopqrstuvwxyz 67890\$

ABCDEFGHIJKLMN OPQRSTUVWXYZ

8 Point No. 150A, 9 Set

### MONOTYPE FACES

The best kind of originality is that which comes after a sound apprenticeship; that which shall prove to be the blending of a firm conception of all useful precedent and the progressive tendencies of an able mind. For, let a man be as able and original as he may, he cannot afford to discard knowledge of what has gone before or what is now going on in his own trade and profession. If the printers of today do not wish to be esteemed too arrogant when they term this calling of theirs an art, they must be willing, and show that they are willing, to subject it to such laws as have made its sister arts so free. All those concerned in what are accepted as the fine arts, the learned sciences, and the professions surround themselves with the history, the literature, and concrete examples of the work with which they are particularly engaged. Yet it is only in rare instances that such an atmosphere, with its material appurtenances, is to be found in a printing office. Art does not flourish in hidden places, nor under restraint, nor in ignorance of what talent and genius have accomplished and are accomplishing throughout the world. For, to follow precedent wisely does not mean to imitate slavishly one great exemplar, but to study all masters faithfully, letting their great achievements sink slowly into the mind

12345 abcdefghijklmnopqrstuvwxyz 67890\$

ABCDEFGHIJKLMN OPQRSTUVWXYZ

ABCDEFGHIJKLMN OPQRSTUVWXYZ

12345 abcdefghijklmnopqrstuvwxyz 67890\$

ABCDEFGHIJKLMN OPQRSTUVWXYZ

7 Point No. 150A, 8½ Set

### MONOTYPE FACES

The best kind of originality is that which comes after a sound apprenticeship; that which shall prove to be the blending of a firm conception of all useful precedent and the progressive tendencies of an able mind. For, let a man be as able and original as he may he cannot afford to discard knowledge of what has gone before or what is now going on in his own trade and profession. If the printers of today do not wish to be esteemed arrogant when they term this calling of theirs an art, they must be willing, and show that they are willing, to subject it to such laws as have made its sister arts so free. All those concerned in what are accepted as the fine arts, the learned sciences, and the professions surround themselves with the history, literature, and the concrete examples of the work with which they are particularly engaged. Yet it is only in very rare instances that such an atmosphere, with its material appurtenances, is to be found in a printing office. Art does not flourish in hidden places nor under restraint, nor in ignorance of what talent and genius have accomplished and are now accomplishing throughout the world. For to follow precedent wisely does not mean to imitate slavishly one great exemplar, but to study all the masters faithfully, letting their great achievements sink slowly into the mind in order that we may patiently derive from the richness of our acquired knowledge and organized system an attitude of our own. The sprightly minded young man, who

12345 abcdefghijklmnopqrstuvwxyz 67890\$

ABCDEFGHIJKLMN OPQRSTUVWXYZ

ABCDEFGHIJKLMN OPQRSTUVWXYZ

12345 abcdefghijklmnopqrstuvwxyz 67890\$

ABCDEFGHIJKLMN OPQRSTUVWXYZ

9 Point No. 150A, 10 Set

### MONOTYPE FACES

The best kind of originality is that which comes after a sound apprenticeship; that which shall prove to be the blending of a firm conception of all useful precedent and the progressive tendencies of an able mind. For, let a man be as able and original as he may, he cannot afford to discard knowledge of what has gone before or what is now going on in his own trade and profession. If the printers of today do not wish to be esteemed arrogant when they term this calling of theirs an art, they must be willing, and show that they are willing, to subject it to such laws as have made its sister arts so free. All those concerned in what are accepted as the fine arts, the learned sciences, and the professions surround themselves with the history, the literature, and concrete examples of the work with which they are particularly engaged. Yet it is only in very rare instances that such an atmosphere, with its material appurtenances, is to be found in a printing office. Art does not flourish in hidden places, nor under restraint, nor in ignor-

12345 abcdefghijklmnopqrstuvwxyz 67890\$

ABCDEFGHIJKLMN OPQRSTUVWXYZ

ABCDEFGHIJKLMN OPQRSTUVWXYZ

12345 abcdefghijklmnopqrstuvwxyz 67890\$

ABCDEFGHIJKLMN OPQRSTUVWXYZ

# No. 150A. Book Arrangement C

## Composition Matrices

10 Point No. 150A, 11 Set

### MONOTYPE FACES

The very best kind of originality is that which comes after a thorough apprenticeship; that which shall prove to be the blending of a firm conception of all useful precedent and the progressive tendencies of an able mind. For, let a man be as able and original as he may, he cannot afford to discard knowledge of what has gone before or what is now going on in his own trade and profession. If the printers of today do not wish to be esteemed arrogant when they term this calling of theirs an art, they must be willing, and show that they are willing, to subject it to such laws as have made its sister arts so free. All those concerned in what are accepted as the fine arts, the learned sciences, and the professions surround themselves with the history, the literature, and concrete examples of the work with which they are particularly engaged. Yet it is

12345 abcdefghijklmnopqrstuvwxyz 67890\$

ABCDEFGHIJKLMN OPQRSTUVWXYZ

ABCDEFGHIJKLMN OPQRSTUVWXYZ

12345 abcdefghijklmnopqrstuvwxyz 67890\$

ABCDEFGHIJKLMN OPQRSTUVWXYZ

11 Point No. 150A, 12 Set

### MONOTYPE FACES

The best kind of originality is that which comes after a sound apprenticeship; that which shall prove to be the blending of a firm conception of all useful precedent and the progressive tendencies of an able mind. For, let a man be as able and original as he may, he cannot afford to discard knowledge of what has gone before or what is now going on in his own trade and profession. If the printers of today do not wish to be esteemed arrogant when they term this calling of theirs an art, they must be willing, and show that they are willing, to subject it to such laws as have made its sister arts so free. All those concerned in what are accepted as the fine arts, the learned sciences, and the

12345 abcdefghijklmnopqrstuvwxyz 6789

ABCDEFGHIJKLMN OPQRSTUVWXYZ

ABCDEFGHIJKLMN OPQRSTUVWXYZ

12345 abcdefghijklmnopqrstuvwxyz 67890\$

ABCDEFGHIJKLMN OPQRSTUVWXYZ

12 Point No. 150A, 12½ Set

### MONOTYPE FACES

The very best kind of originality is that which comes after a sound apprenticeship; that which shall prove to be the blending of a firmer conception of all useful precedent and of the progressive tendencies of an able mind. For, let any man be as able and original as he may, he cannot afford to discard knowledge of what has gone before or what is now going on in his own trade and his profession. If the printers of today do not wish to be esteemed too arrogant

12345 abcdefghijklmnopqrstuvwxyz 67890\$

ABCDEFGHIJKLMN OPQRSTUVWXYZ

ABCDEFGHIJKLMN OPQRSTUVWXYZ

12345 abcdefghijklmnopqrstuvwxyz 67890\$

ABCDEFGHIJKLMN OPQRSTUVWXYZ

### MONOTYPE FACES

The very best kind of originality is that which comes after a sound apprenticeship; that which shall prove to be the blending of a firmer conception of all useful precedent and of the progressive tendencies of an able mind. For, let any man be as able and original as he may, he cannot afford to discard knowledge of what has gone before or what is now going on in his own trade and his profession. If the printers of today do not wish to be esteemed too arrogant when they term this calling of theirs an art, they must be willing, and show that

14 Point No. 150

**THE LAW AND THE PROFITS**  
Go Hand in Hand if the Composition of Your Legal Work is Done on  
the Versatile and Busy Monotype  
\$1234567890

18 Point No. 150

**SETTING TYPE WITH TWEEZERS**  
Is Expensive Composition. You Won't Run Out of  
Sorts or Patience the Monotype Way  
\$1234567890

24 Point No. 150

**THE OLD NICK**  
Caused by "Pulling Type" Won't Bob  
up in Your Pressroom  
\$1234567890

30 Point No. 150

**RUSH WORK**  
Is Ordinary Work in Monotype  
Composing Rooms  
\$1234567890

36 Point No. 150

**SOMETIME**  
You Will Buy the Monotype  
\$1234567890

14 Point No. 1501

**NO NEWSPAPER OFFICE**

*Has an efficient composing room without an abundant supply of leads and spacing material at all times*

**\$1234567890**

18 Point No. 1501

**ABCDEFGHIJKLMNOPQRSTUVWXYZ & Æ Æ**  
*abcdefghijklmnopqrstuvwxyæœfi flffiffll*

*.,:;- ' ! ?*

**\$1234567890**

A full font contains 81 characters as listed above

24 Point No. 1501

**THE MONOTYPE LEAD MOLD**

*Will make leads of the proper length with wonderful rapidity*

**\$1234567890**

30 Point No. 1501

**A STANDARD UNIT**

*It can be attached to any machine now in your plant*

**\$1234567890**

36 Point No. 1501

**NEW LEADS**

*May be used for each job*

**\$1234567890**

# No. 152A. Book Arrangement C

## Composition Matrices

8 Point No. 152A, 8½ Set

### MONOTYPE FACES

The best kind of originality is that which comes after a sound apprenticeship; that which shall prove to be the blending of a firm conception of all useful precedent and the progressive tendencies of an able mind. For, let a man be as able and original as he may, he cannot afford to discard knowledge of what has gone before or what is now going on in his own trade and profession. If the printers of today do not wish to be esteemed arrogant when they term this calling of theirs an art, they must be willing, and show that they are willing, to subject it to such laws as have made its sister arts so free. All those concerned in what are accepted as the fine arts, the learned sciences, and the professions surround themselves with the history, the literature, and concrete examples of the work with which they are particularly engaged. Yet it is only in very rare instances that such an atmosphere, with its material appurtenances, is to be found in a printing office. Art does not flourish in hidden places, nor under restraint, nor in ignorance of what talent and genius have accomplished and are now accomplishing throughout the world. For to follow precedent wisely does not mean to imitate slavishly one great exemplar, but to study all the masters faithfully, letting their great achievements sink slowly into the mind in order that we may patiently derive from the richness of our acquired knowledge and organized system an attitude of our own. *The sprightly minded young man, who*

12345      abcdefghijklmnopqrstuvwxyz      67890\$  
ABCDEF GHIJKL MNOPQRST UVWXYZ  
ABCDEF GHIJKL MNOPQRST UVWXYZ  
12345      abcdefghijklmnopqrstuvwxyz      67890\$  
ABCDEF GHIJKL MNOPQRST UVWXYZ

10 Point No. 152A, 10 Set

### MONOTYPE FACES

The best kind of originality is that which comes after a sound apprenticeship; that which shall prove to be the blending of a firm conception of all useful precedent and the progressive tendencies of an able mind. For, let a man be as able and original as he may, he cannot afford to discard knowledge of what has gone before or what is now going on in his own trade and profession. If the printers of today do not wish to be esteemed arrogant when they term this calling of theirs an art, they must be willing, and show that they are willing, to subject it to such laws as have made its sister arts so free. All those who are concerned in what are accepted as the fine arts, the learned sciences, and the professions surround themselves with the history, literature, and concrete examples of the work with which they are particularly engaged. Yet it is only in very rare instances that such an atmosphere, with its material appurtenances, is to be found in a printing office.

12345      abcdefghijklmnopqrstuvwxyz      67890\$  
ABCDEF GHIJKL MNOPQRST UVWXYZ  
ABCDEF GHIJKL MNOPQRST UVWXYZ  
12345      abcdefghijklmnopqrstuvwxyz      67890\$  
ABCDEF GHIJKL MNOPQRST UVWXYZ

# No. 175A. Book Arrangement C

## Composition Matrices

5 Point No. 175A, 6 Set

### MONOTYPE FACES

The best kind of originality is that which comes after a sound apprenticeship; that which shall prove to be the blending of a firm conception of all useful precedent and the progressive tendencies of an able mind. For, let a man be as able and original as he may, he cannot afford to discard knowledge of what has gone before or what is now going on in his own trade and profession. If the printers of today do not wish to be esteemed arrogant when they term this calling of theirs an art, they must be willing, and show that they are willing, to subject it to such laws as have made its sister arts so free. All those concerned in what are accepted as the fine arts, the learned sciences and the professions, surround themselves with the history, literature, and concrete examples of the work with which they are particularly engaged. Yet it is only in rare instances that such an atmosphere, with its material appurtenances, is to be found in a printing office. Art does not flourish in hidden places, nor under restraint, nor in ignorance of what talent and genius have accomplished and are accomplishing throughout the world. For to follow all precedent wisely does not mean to imitate slavishly one great exemplar, but to study all masters faithfully, letting their great achievements sink slowly into the mind in order that we may patiently derive from the richness of our acquired knowledge and organized system an attitude of our own. The sprightly minded young man, who with his first business breath projects the new and startling, inevitably becomes tiresome, and is driven to an early disappearance; while the slower, more solidly endowed student will at least spend as much of his time in avoiding mistakes as in evolving brilliant schemes wherewith to dazzle his contemporaries. The best kind of originality is that which comes after a sound apprenticeship; that which shall prove to be the blending of a firm conception of all useful precedent and the progressive tendencies of an able mind. For, let any man be as able and original as he may, he cannot afford to discard knowledge of what has gone before or is now going on in his own trade and profession. If the printers of today do not wish to be esteemed arrogant when they term this calling of theirs an art, they must be willing and show that they are willing, to subject it to such laws as have made its sister arts so free. All those concerned in what are accepted as the fine arts, the learned sciences and professions, surround themselves with the history, literature, and concrete examples of the work with which they are particularly engaged. Yet it is only in very rare instances that such an atmosphere, with its material appurtenances, is to be found in a printing office. Art does not flourish in hidden places, nor under restraint, nor in ignorance of what talent and genius have accomplished and are accomplishing throughout the world. For to follow all precedent wisely does not mean to imitate slav-

|       |   |         |
|-------|---|---------|
| 12345 | abode <span style="font-family: monospace;">fghijklm</span> nopqr <span style="font-family: monospace;">stuvwxyz</span> | 67890\$ |
|       | ABCDEF <span style="font-family: monospace;">GHIJKL</span> MNOPQR <span style="font-family: monospace;">STUVWXYZ</span> |         |
|       | ABCDEF <span style="font-family: monospace;">GHIJKL</span> MNOPQR <span style="font-family: monospace;">STUVWXYZ</span> |         |
| 12345 | abode <span style="font-family: monospace;">fghijklm</span> nopqr <span style="font-family: monospace;">stuvwxyz</span> | 67890\$ |
|       | ABCDEF <span style="font-family: monospace;">GHIJKL</span> MNOPQR <span style="font-family: monospace;">STUVWXYZ</span> |         |

7 Point No. 175A, 8 Set

### MONOTYPE FACES

The best kind of originality is that which comes after a sound apprenticeship; that which shall prove to be the blending of a firm conception of all useful precedent and the progressive tendencies of an able mind. For, let a man be as able and original as he may, he cannot afford to discard knowledge of what has gone before or what is now going on in his own trade and profession. If the printers of today do not wish to be esteemed arrogant when they term this calling of theirs an art, they must be willing, and show that they are willing, to subject it to such laws as have made its sister arts so free. All those concerned in what are accepted as the fine arts, the learned sciences and the professions, surround themselves with the history, literature, and the concrete examples of the work with which they are particularly engaged. Yet it is only in rare instances that such an atmosphere, with its material appurtenances, is to be found in a printing office. Art does not flourish in hidden places, nor under restraint, nor in ignorance of what talent and genius have accomplished and are accomplishing throughout the world. For to follow precedent wisely does not mean to imitate slavishly one great exemplar, but to study all masters faithfully, letting their great achievements sink slowly into the mind in order that we may patiently derive from the richness of our acquired knowledge and organized system an attitude of our own. The sprightly minded young man, who with his first business breath projects the new and startling, inevitably becomes tiresome, and is driven to an early disappearance; while the slower, more solidly endowed student will at least spend as much of his time in avoiding mistakes

|       |   |         |
|-------|---|---------|
| 12345 | abcde <span style="font-family: monospace;">fghijklm</span> nopqr <span style="font-family: monospace;">stuvwxyz</span> | 67890\$ |
|       | ABCDEF <span style="font-family: monospace;">GHIJKL</span> MNOPQR <span style="font-family: monospace;">STUVWXYZ</span> |         |
|       | ABCDEF <span style="font-family: monospace;">GHIJKL</span> MNOPQR <span style="font-family: monospace;">STUVWXYZ</span> |         |
| 12345 | abcde <span style="font-family: monospace;">fghijklm</span> nopqr <span style="font-family: monospace;">stuvwxyz</span> | 67890\$ |
|       | ABCDEF <span style="font-family: monospace;">GHIJKL</span> MNOPQR <span style="font-family: monospace;">STUVWXYZ</span> |         |

6 Point No. 175A, 7 Set

### MONOTYPE FACES

The best kind of originality is that which comes after a sound apprenticeship; that which shall prove itself to be the blending of a firm conception of all useful precedent and the progressive tendencies of an able mind. For, let a man be as able and original as he may, he cannot afford to discard knowledge of what has gone before or what is now going on in his own trade and profession. If the printers of today do not wish to be esteemed arrogant when they term this calling of theirs an art, they must be willing, and show that they are willing, to subject it to such laws as have made its sister arts so free. All those concerned in what are accepted as the fine arts, the learned sciences and professions, surround themselves with the history, literature, and concrete examples of the work with which they are particularly engaged. Yet it is only in very rare instances that such an atmosphere, with its material appurtenances, is to be found in the printing office. Art does not flourish in hidden places, nor under restraint, nor in ignorance of what talent and genius have accomplished and are accomplishing throughout the world. For to follow precedent wisely does not mean to imitate slavishly one great exemplar, but to study all masters faithfully, letting their great achievements sink slowly into the mind in order that we may patiently derive from the richness of our acquired knowledge and organized system an attitude of our own. The sprightly minded young man, who with his first business breath projects the new and startling, inevitably becomes tiresome, and is driven to an early disappearance; while the slower and more solidly endowed student will at least spend as much of his time in avoiding mistakes as in evolving brilliant schemes wherewith to dazzle his contemporaries. The best kind of originality is that which comes after a sound apprenticeship; that which shall prove itself to be the blending of a firm conception of all useful precedent and the progressive tendencies of an able mind. For, let any man be as able and original as he

|       |   |         |
|-------|---|---------|
| 12345 | abode <span style="font-family: monospace;">fghijklm</span> nopqr <span style="font-family: monospace;">stuvwxyz</span> | 67890\$ |
|       | ABCDEF <span style="font-family: monospace;">GHIJKL</span> MNOPQR <span style="font-family: monospace;">STUVWXYZ</span> |         |
|       | ABCDEF <span style="font-family: monospace;">GHIJKL</span> MNOPQR <span style="font-family: monospace;">STUVWXYZ</span> |         |
| 12345 | abcde <span style="font-family: monospace;">fghijklm</span> nopqr <span style="font-family: monospace;">stuvwxyz</span> | 67890\$ |
|       | ABCDEF <span style="font-family: monospace;">GHIJKL</span> MNOPQR <span style="font-family: monospace;">STUVWXYZ</span> |         |

8 Point No. 175A, 8½ Set

### MONOTYPE FACES

The best kind of originality is that which comes after a sound apprenticeship; that which shall prove to be the blending of a firm conception of all useful precedent and the progressive tendencies of an able mind. For, let a man be as able and original as he may, he cannot afford to discard knowledge of what has gone before or what is now going on in his own trade and profession. If the printers of today do not wish to be esteemed arrogant when they term this calling of theirs an art, they must be willing, and show that they are willing, to subject it to such laws as have made its sister arts so free. All those concerned in what are accepted as the fine arts, the learned sciences and the professions, surround themselves with the history, literature, and the concrete examples of the work with which they are particularly engaged. Yet it is only in very rare instances that such an atmosphere, with its material appurtenances, is to be found in a printing office. Art does not flourish in hidden places, nor under restraint, nor in ignorance of what talent and genius have accomplished and are now accomplishing throughout the world. For to follow precedent wisely does not mean to imitate slavishly one great exemplar, but to study all the masters faithfully, letting their great achievements sink slowly into the mind in order that we may patiently derive from the richness

|       |   |         |
|-------|---|---------|
| 12345 | abcde <span style="font-family: monospace;">fghijklm</span> nopqr <span style="font-family: monospace;">stuvwxyz</span> | 67890\$ |
|       | ABCDEF <span style="font-family: monospace;">GHIJKL</span> MNOPQR <span style="font-family: monospace;">STUVWXYZ</span> |         |
|       | ABCDEF <span style="font-family: monospace;">GHIJKL</span> MNOPQR <span style="font-family: monospace;">STUVWXYZ</span> |         |
| 12345 | abcde <span style="font-family: monospace;">fghijklm</span> nopqr <span style="font-family: monospace;">stuvwxyz</span> | 67890\$ |
|       | ABCDEF <span style="font-family: monospace;">GHIJKL</span> MNOPQR <span style="font-family: monospace;">STUVWXYZ</span> |         |

# No. 175A. Book Arrangement C

## Composition Matrices

9 Point No. 175A, 9 set

### MONOTYPE FACES

The best kind of originality is that which comes after a sound apprenticeship; that which shall prove to be the blending of a firm conception of all useful precedent and the progressive tendencies of an able mind. For, let a man be as able and original as he may, he cannot afford to discard knowledge of what has gone before or what is now going on in his own trade and profession. If the printers of today do not wish to be esteemed arrogant when they term this calling of theirs an art, they must be willing, and show that they are willing, to subject it to such laws as have made its sister arts so free. All those concerned in what are accepted as the fine arts, the learned sciences and the professions, surround themselves with the history, literature, and concrete examples of the work with which they are particularly engaged. Yet it is only in rare instances that such an atmosphere, with its material appurtenances, is to be found in a printing office. *Art does not flourish in the hidden places, nor under restraint, nor in*

12345 abcdefghijklmnopqrstuvwxyz 67890\$  
ABCDEFGHIJKLMNOPQRSTUVWXYZ  
ABCDEFGHIJKLMNOPQRSTUVWXYZ  
12345 abcdefghijklmnopqrstuvwxyz 67890\$  
ABCDEFGHIJKLMNOPQRSTUVWXYZ

11 Point No. 175A, 11 Set

### MONOTYPE FACES

The very best kind of originality is that which comes after a thorough apprenticeship; that which shall prove to be the blending of a very firm conception of all useful precedent and the progressive tendencies of an able mind. For, let a man be as able and original as he may, he cannot afford to discard knowledge of what has gone before or what is now going on in his own trade and profession. If the printers of today do not wish to be esteemed arrogant when they term this calling of theirs an art, they must be willing, and show that they are willing, to subject it to such laws as have made its sister arts so free. All those concerned in what are accepted as the fine arts, the learned sciences and professions, surround

12345 abcdefghijklmnopqrstuvwxyz 67890\$  
ABCDEFGHIJKLMNOPQRSTUVWXYZ  
ABCDEFGHIJKLMNOPQRSTUVWXYZ  
12345 abcdefghijklmnopqrstuvwxyz 67890\$  
ABCDEFGHIJKLMNOPQRSTUVWXYZ

10 Point No. 175A, 10 Set

### MONOTYPE FACES

The best kind of originality is that which comes after a sound apprenticeship; that which shall prove to be the blending of a firm conception of all useful precedent and the progressive tendencies of an able mind. For, let a man be as able and original as he may, he cannot afford to discard knowledge of what has gone before or what is now going on in his own trade and profession. If the printers of today do not wish to be esteemed arrogant when they term this calling of theirs an art, they must be willing, and show that they are willing, to subject it to such laws as have made its sister arts so free. All those who are concerned in what are accepted as the fine arts, the learned sciences and the professions, surround themselves with the history, literature, and concrete examples of the work with which they are particularly

12345 abcdefghijklmnopqrstuvwxyz 67890\$  
ABCDEFGHIJKLMNOPQRSTUVWXYZ  
ABCDEFGHIJKLMNOPQRSTUVWXYZ  
12345 abcdefghijklmnopqrstuvwxyz 67890\$  
ABCDEFGHIJKLMNOPQRSTUVWXYZ

12 Point No. 175A, 12 Set

### MONOTYPE FACES

The best kind of originality is that which comes after a sound apprenticeship; that which shall prove to be the blending of a firm conception of all useful precedent and the progressive tendencies of an able mind. For, let any man be as able and original as he may, he cannot afford to discard knowledge of what has gone before or what is now going on in his own trade and profession. If the printers of today do not wish to be esteemed arrogant when they term this calling of theirs an art, they must be willing, and show that they are willing, to subject it to such laws as

1234 abcdefghijklmnopqrstuvwxyz 567\$  
ABCDEFGHIJKLMNOPQRSTUVWXYZ  
ABCDEFGHIJKLMNOPQRSTUVWXYZ  
1234 abcdefghijklmnopqrstuvwxyz 567\$  
ABCDEFGHIJKLMNOPQRSTUVWXYZ



14 Point No. 175

**THE HIGHEST QUALITY OF PRINTING**

Is the kind that pays the largest profits and holds customers. It is one of the essentials of a successful business

**\$1234567890**

18 Point No. 175

ABCDEFGHIJKLMN**OP**QRSTUVWXYZ&ÆŒ.,;:'!?  
abcdefghijklmnopqrstu**vw**xyzæœfiflffiffil

**\$1234567890**

A full font consists of 81 characters as listed above

24 Point No. 175

**OUR SUCCESS**

Is based upon the success of the Monotype printer who is producing quality

**\$1234567890**

30 Point No. 175

**A GREAT ASSORTMENT**

Of beautiful faces is at your command in the Matrix Library

**\$1234567890**

36 Point No. 175

**A TYPE CASTER**

Is a good thing to start with

**\$1234567890**

14 Point No. 1751

**EVERY ADVERTISING MAN SHOULD KNOW**

*Where the Monotype stands in relation to the thoughts he writes, the space he buys and the white paper he uses*

**\$1234567890**

18 Point No. 1751

**MONOTYPE COMPOSITION**

*Is clean, accurate, legible, neat and well spaced—all that can be said of good composition*

**\$1234567890**

24 Point No. 1751

**THE MONOTYPE**

*Is a machine that brings into existence new type and new rule for every job*

**\$1234567890**

30 Point No. 1751

**MONOTYPE TYPE**

*Answers every possible requirement of particular advertisers*

**\$1234567890**

36 Point No. 1751

**MONOTYPE**

*Will make a good impression*

**\$1234567890**

24 Point No. 375

**THERE ARE NO SLOW SPOTS**  
**On the Keyboard; There is the Same Identical**  
**Movement to Every Key**  
**\$1234567890**

30 Point No. 375

**THE MONOTYPE**  
**Is the Only Flexible Machine Known to**  
**the Printing Industry**  
**\$1234567890**

36 Point No. 375

**NO OFFICE**  
**Is Complete without a Monotype**  
**\$1234567890**

24 Point No. 3751

**THE MONOTYPE**

*Is the only Composing Machine that Furnishes  
a Product Identical with Foundry Type*

**\$1234567890**

30 Point No. 3751

**THE MONOTYPE SYSTEM**

*Means the Complete Revolution of Your  
Composing Room*

**\$1234567890**

36 Point No. 3751

**RAISE YOUR**

*Quality and Reduce all Complaints*

**\$1234567890**

# No. 275J. Job Arrangement C2

## Composition Matrices

6 Point No. 275J, 7 Set

### MONOTYPE FACES

The best kind of originality is that which comes after a sound apprenticeship; that which shall prove to be the blending of a firm conception of all useful precedent and the progressive tendencies of an able mind. For, let a man be as able and original as he may, he cannot afford to discard knowledge of what has gone before or what is now going on in his own trade or his profession. If the printers of today do not wish to be esteemed arrogant when they term this calling of theirs an art, they must be willing, and show that they are willing, to subject it to such laws as have made its sister arts so free. All those concerned in what are accepted as the fine arts, the learned sciences, and professions surround themselves with the history, the literature, and concrete examples of the work with which they are particularly engaged. Yet it is only in very rare instances that such an atmosphere, with its material appurtenances, is to be found in a printing office. Art does not flourish in hidden places, nor under restraint, nor in ignorance of what talent and genius have accomplished and are accomplishing throughout the world. For to follow all precedent wisely does not mean to imitate too slavishly one great exemplar, but to study all masters faithfully, letting their great achievements sink slowly into the mind in order that we may patiently derive from the richness of our acquired knowledge and organized system an attitude of our own. The sprightly minded young man, who with his first business breath projects the new and startling, inevitably becomes tiresome, and is driven to an early disappearance; while the slower, more solidly endowed student will at least spend as much of his time in avoiding mistakes as in evolving brilliant schemes wherewith to dazzle his contemporaries. The best kind of originality is that which comes after a sound apprenticeship; that which shall prove to

abcdefghijklmnopqrstuvwxyz

ABCDEFGHIJKLMNQPQRSTUVWXYZ

\$1234567890

10 Point No. 275J, 10 Set

### MONOTYPE FACES

The best kind of originality is that which comes after a thorough apprenticeship; that which shall prove to be the blending of a firm conception of all useful precedent and the progressive tendencies of an able mind. For, let a man be as able and original as he may, he cannot afford to discard knowledge of what has gone before or what is now going on in his own trade and profession. If the printers of today do not wish to be esteemed too arrogant when they term this calling of theirs an art, they must be willing, and show that they are willing, to subject it to such laws as have made its sister arts so free. All those concerned in what are accepted as the fine arts, the learned sciences, and professions surround themselves with the history, literature, and concrete examples of the work with which they are particularly engaged. Yet it is only in rare instances that such an atmosphere, with these material appurtenances, is to be found in the printing office.

abcdefghijklmnopqrstuvwxyz

ABCDEFGHIJKLMNQPQRSTUVWXYZ

\$1234567890

8 Point No. 275J, 8½ Set

### MONOTYPE FACES

The best kind of originality is that which comes after a thorough apprenticeship; that which shall prove to be the blending of a firm conception of all useful precedent and the progressive tendencies of an able mind. For, let a man be as able and original as he may, he cannot afford to discard knowledge of what has gone before or what is now going on in his own trade or his profession. If the printers of today do not wish to be esteemed arrogant when they term this calling of theirs an art, they must be willing, and show that they are willing, to subject it to such laws as have made its sister arts so free. All those concerned in what are accepted as the fine arts, the learned sciences, and professions surround themselves with the history, the literature, and the concrete examples of the work with which they are particularly engaged. Yet it is only in very rare instances that such an atmosphere, with its material appurtenances, is to be found in a printing office. Art does not flourish in hidden places, nor under restraint, nor in ignorance of what talent and genius have accomplished and are accomplishing throughout the world. For to follow precedent wisely does not mean to imitate slavishly one great exemplar,

abcdefghijklmnopqrstuvwxyz

ABCDEFGHIJKLMNQPQRSTUVWXYZ

\$1234567890

12 Point No. 275J, 12 Set

### MONOTYPE FACES

The best kind of originality is that which comes after a sound apprenticeship; that which shall prove to be the blending of a firm conception of all useful precedent and the progressive tendencies of an able mind. For, let a man be as able and original as he may, he cannot afford to discard a knowledge of what has gone before or what is now going on in his own trade and profession. If the printers of today do not wish to be esteemed arrogant when they term this calling of theirs an art, they must be willing, and show that they are willing, to subject it to such laws as have made its sister arts so free. All those who are concerned in what

abcdefghijklmnopqrstuvwxyz

ABCDEFGHIJKLMNQPQRSTUVWXYZVW

\$1234567890

14 Point No. 275

**NON-DISTRIBUTION WILL REPAY**

**The Investment of a Monotype in Less Than Two Years, and Keep Right  
on Giving Profits for Many Years to Come  
\$1234567890**

18 Point No. 275

**THROUGH THIS SYSTEM,**

**Which the Monotype Created, it Reduces the Actual  
Hour Cost of Hand Composition  
\$1234567890**

24 Point No. 275

**LEADS, SLUGS AND RULES**

**Made on Monotype Lead and Slug Attach-  
ment Always True to Size  
\$1234567890**

30 Point No. 275

**OUR TYPE-&-RULE**

**Caster Continuously Supplies Brand  
New Type for the Cases  
\$1234567890**

36 Point No. 275

**VERSATILITY IS ONLY**

**One of the Many Good Features  
\$1234567890**

# No. 275K. Job Arrangement C2

## Composition Matrices

6 Point No. 275K, 7 Set

### MONOTYPE FACES

The best kind of originality is that which comes after a sound apprenticeship; that which shall prove to be the blending of a firm conception of all useful precedent and the progressive tendencies of an able mind. For, let a man be as able and original as he may, he cannot afford to discard knowledge of what has gone before or what is now going on in his own trade and profession. If the printers of today do not wish to be esteemed arrogant when they term this calling of theirs an art they must be willing, and show that they are willing, to subject it to such laws as have made its sister arts so free. All those concerned in what are accepted as the fine arts, the learned sciences, and professions surround themselves with the history, the literature, and concrete examples of the work with which they are particularly engaged. Yet it is only in very rare instances that such an atmosphere, with its material appurtenances, is to be found in a printing office. Art does not flourish in hidden places, nor under restraint, nor in ignorance of what talent and genius have accomplished and are accomplishing throughout the world. For to follow precedent wisely does not mean to imitate slavishly one great exemplar, but to study all masters faithfully, letting their great achievements sink slowly into the mind in order that we may patiently derive from the richness of our acquired knowledge and organized system an attitude of our own. The sprightly minded young man, who with his first business breath projects the new and startling, inevitably becomes tiresome, and is driven to an early disappearance; while the slower, more solidly endowed student will at least spend as much of his time in avoiding mistakes as in evolving brilliant schemes wherewith to dazzle his contemporaries. The best kind of originality is that which comes after a sound apprenticeship; that which shall prove to

abcdefghijklmnopqrstuvwxy  
ABCDEFGHIJKLMNPOQRSTUVWXYZ  
\$1234567890

10 Point No. 275K, 10 Set

### MONOTYPE FACES

The best kind of originality is that which comes after a sound apprenticeship; that which shall prove to be the blending of a firm conception of all useful precedent and the progressive tendencies of an able mind. For, let any man be as able and original as he may, he cannot afford to entirely discard knowledge of what has gone before or what is now going on in his own trade and profession. If the printers of today do not wish to be esteemed too arrogant when they term this calling of theirs an art, they must be willing, and show that they are willing, to subject it to such laws as have made its sister arts so free. All those concerned in what are accepted as the fine arts, the learned sciences, and the professions surround themselves with the history, literature, and concrete examples of the work with which they are particularly engaged. Yet it is only in very rare instances that such an atmosphere, with

abcdefghijklmnopqrstuvwxy  
ABCDEFGHIJKLMNPOQRSTUVWXYZ  
\$1234567890

8 Point No. 275K, 8 1/2 Set

### MONOTYPE FACES

The best kind of originality is that which comes after a sound apprenticeship; that which shall prove to be the blending of a firm conception of all useful precedent and the progressive tendencies of an able mind. For, let a man be as able and original as he may, he cannot afford to discard knowledge of what has gone before or what is now going on in his own trade or his profession. If the printers of today do not wish to be esteemed arrogant when they term this calling of theirs an art, they must be willing, and show that they are willing, to subject it to such laws as have made its sister arts so free. All those concerned in what are accepted as the fine arts, the learned sciences, and professions surround themselves with the history, the literature, and the concrete examples of the work with which they are particularly engaged. Yet it is only in very rare instances that such an atmosphere, with its material appurtenances, is to be found in a printing office. Art does not flourish in hidden places, nor under restraint, nor in ignorance of what talent and genius have accomplished and are accomplishing throughout the world. For to follow precedent wisely does not mean to imitate slavishly one great exemplar,

abcdefghijklmnopqrstuvwxy  
ABCDEFGHIJKLMNPOQRSTUVWXYZ  
\$1234567890

12 Point No. 275K, 12 Set

### MONOTYPE FACES

The best kind of originality is that which comes after a sound apprenticeship; that which shall prove to be the blending of a firm conception of all useful precedent and the progressive tendencies of an able mind. For, let a man be as able and original as he may, he cannot afford to discard a knowledge of what has gone before or what is now going on in his own trade and profession. If the printers of today do not wish to be esteemed arrogant when they term this calling of theirs an art, they must be willing, and show that they are willing, to subject it to such laws as have made its sister arts so free. All those who are concerned in what

abcdefghijklmnopqrstuvwxy  
ABCDEFGHIJKLMNPOQRSTUVWXYZ  
\$1234567890

14 Point No. 2751

**THE FACTS IN THE CASE**

*The Monotype eliminates Costly Non-productive Time and Reduces the Cost of the Work done in the Productive Time*

**\$1234567890**

18 Point No. 2751

**IN THE MONOTYPE PLANT**

*There is Never any Worry by the Hurry of a Rush of Copy at the Last Minute*

**\$1234567890**

24 Point No. 2751

**MONOTYPE MATERIAL**

*Makes the Modern Composing Room a Much Pleasanter Place to Work in*

**\$1234567890**

30 Point No. 2751

**NON-DISTRIBUTION**

*Saves the Time of your High-Salaried, Skilled Job Compositors*

**\$1234567890**

36 Point No. 2751

**DON'T WASTE**

*Your Good Coin for Lost Time*

**\$1234567890**



No. 194

Class C Matrices. Fonts shown on this page  
Not Included in Library and Will Not be Leased

Electro Display  
Matrices

12 Point No. 194

**IF YOU EVER BOUGHT SHADED TYPE FACES**

You know all about the High Cost of keeping the cases sorted-up with expensive foundry sorts, for the first trip to the pressroom means old type.

**\$1234567890**

14 Point No. 194

**THE MONOTYPE TYPE CASTER IS A NECESSITY**

Where the best results are desired from the use of Fine Shaded Faces.

It supplies new type for every job

**\$1234567890**

18 Point No. 194

**DO NOT LIMIT THE WORK**

By having to use a small font of purchased type. Cast all the new type you need on the Monotype

**\$1234567890**

24 Point No. 194

**ABCDEFGHIJKLMNOPQRSTUVWXYZ&  
abcdefghijklmnopqrstuvwxyzfifffffiffll.,;:-!?**

**\$1234567890**

A full font consists of 77 characters as listed above

30 Point No. 194

**BEAUTIFUL NEW FACES**

Added to our list of up-to-date fonts

**\$1234567890**

36 Point No. 194

**ALL OLD TYPE**

Can be Converted into New Faces

**\$1234567890**

# No. 15E. Book Arrangement C

## Composition Matrices

### 6 Point No. 15E, 7 Set

#### MONOTYPE FACES

The best kind of originality is that which comes after a sound apprenticeship; that which shall prove itself to be the blending of a firm conception of useful precedent and the progressive tendencies of an able mind. For, let a man be as able and original as he may, he cannot afford to discard knowledge of what has gone before or what is now going on in his own trade and profession. If the printers of today do not wish to be esteemed arrogant when they term this calling of theirs an art, they must be willing, and show that they are willing, to subject it to such laws as have made its sister arts so free. All those concerned in what are accepted as the fine arts, the learned sciences, and professions surround themselves with the history, literature, and concrete examples of work with which they are particularly engaged. Yet it is only in very rare instances that such an atmosphere, with its material appurtenances, is to be found in the printing office. Art does not flourish in hidden places, nor under restraint, nor in ignorance of what talent and genius have accomplished and are accomplishing throughout the world. For to follow precedent wisely does not mean to imitate slavishly one great exemplar, but to study all the masters faithfully, letting their great achievements sink slowly into the mind in order that we may patiently derive from the richness of our acquired knowledge and organized system an attitude of our own. The sprightly minded young man, who with his first business breath projects the new and startling, inevitably becomes tiresome, and is driven to an early disappearance; while the slower and more solidly endowed student will at least spend as much of his time in avoiding mistakes as in evolving brilliant schemes wherewith to dazzle his contemporaries. The best kind of originality is that which comes after a sound apprenticeship; that which shall prove itself to be the blending of a firm conception of all useful precedent and the progressive tendencies of an able mind. For, let any man be as able and original as he

12345      abcdefghijklmnopqrstuvwxyz      67890\$  
 ABCDEFGHIJKLMNOPQRSTUVWXYZ  
 ABCDEFGHIJKLMNOPQRSTUVWXYZ  
 12345      abcdefghijklmnopqrstuvwxyz      67890\$  
 ABCDEFGHIJKLMNOPQRSTUVWXYZ

### 8 Point No. 15E, 8½ Set

#### MONOTYPE FACES

The best kind of originality is that which comes after a sound apprenticeship; that which shall prove to be the blending of a firm conception of all useful precedent and the progressive tendencies of an able mind. For, let a man be as able and original as he may, he cannot afford to discard knowledge of what has gone before or what is now going on in his own trade and profession. If the printers of today do not wish to be esteemed arrogant when they term this calling of theirs an art, they must be willing, and show that they are willing, to subject it to such laws as have made its sister arts so free. All those concerned in what are accepted as the fine arts, the learned sciences, and the professions surround themselves with the history, the literature, and concrete examples of the work with which they are particularly engaged. Yet it is only in very rare instances that such an atmosphere, with its material appurtenances, is to be found in a printing office. Art does not flourish in hidden places, nor under restraint, nor in ignorance of what talent and genius have accomplished and are now accomplishing throughout the world. For to follow precedent wisely does not mean to imitate slavishly one great exemplar, but to study all the masters faithfully, letting their great achievements sink slowly into the mind in order that we may patiently derive from the richness

12345      abcdefghijklmnopqrstuvwxyz      67890\$  
 ABCDEFGHIJKLMNOPQRSTUVWXYZ  
 ABCDEFGHIJKLMNOPQRSTUVWXYZ  
 12345      abcdefghijklmnopqrstuvwxyz      67890\$  
 ABCDEFGHIJKLMNOPQRSTUVWXYZ

### 7 Point No. 15E, 8 Set

#### MONOTYPE FACES

The best kind of originality is that which comes after a sound apprenticeship; that which shall prove to be the blending of a firm conception of all useful precedent and the progressive tendencies of an able mind. For, let a man be as able and original as he may, he cannot afford to discard knowledge of what has gone before or what is now going on in his own trade and profession. If the printers of today do not wish to be esteemed arrogant when they term this calling of theirs an art, they must be willing, and show that they are willing, to subject it to such laws as have made its sister arts so free. All those concerned in what are accepted as the fine arts, the learned sciences, and the professions surround themselves with the history, the literature, and concrete examples of the work with which they are particularly engaged. Yet it is only in rare instances that such an atmosphere, with its material appurtenances, is to be found in a printing office. Art does not flourish in hidden places, nor under restraint, nor in ignorance of what talent and genius have accomplished and are accomplishing throughout the world. For to follow precedent wisely does not mean to imitate slavishly one great exemplar, but to study all masters faithfully, letting their great achievements sink slowly into the mind in order that we may patiently derive from the richness of our acquired knowledge and organized system an attitude of our own. The sprightly minded young man, who with his first business breath projects the new and startling, inevitably becomes tiresome, and is driven to an early

12345      abcdefghijklmnopqrstuvwxyz      67890\$  
 ABCDEFGHIJKLMNOPQRSTUVWXYZ  
 ABCDEFGHIJKLMNOPQRSTUVWXYZ  
 12345      abcdefghijklmnopqrstuvwxyz      67890\$  
 ABCDEFGHIJKLMNOPQRSTUVWXYZ

### 9 Point No. 15E, 9 Set

#### MONOTYPE FACES

The best kind of originality is that which comes after a sound apprenticeship; that which shall prove to be the blending of a firm conception of all useful precedent and the progressive tendencies of an able mind. For, let a man be as able and original as he may, he cannot afford to discard knowledge of what has gone before or what is now going on in his own trade and profession. If the printers of today do not wish to be esteemed arrogant when they term this calling of theirs an art, they must be willing, and show that they are willing, to subject it to such laws as have made its sister arts so free. All those concerned in what are accepted as the fine arts, the learned sciences, and the professions surround themselves with the history, literature, and concrete examples of the work with which they are particularly engaged. Yet it is only in rare instances that such an atmosphere, with its material appurtenances, is to be found in a printing office. Art does not flourish in hidden places, nor under restraint, nor in ignorance of what talent and genius have accomplished and are now accomplishing throughout the world. For to follow

12345      abcdefghijklmnopqrstuvwxyz      67890\$  
 ABCDEFGHIJKLMNOPQRSTUVWXYZ  
 ABCDEFGHIJKLMNOPQRSTUVWXYZ  
 12345      abcdefghijklmnopqrstuvwxyz      67890\$  
 ABCDEFGHIJKLMNOPQRSTUVWXYZ

# No. 15E. Book Arrangement C

## Composition Matrices

10 Point No. 15E, 10 Set

### MONOTYPE FACES

The best kind of originality is that which comes after a sound apprenticeship; that which shall prove to be the blending of a firm conception of all useful precedent and the progressive tendencies of an able mind. For, let a man be as able and original as he may, he cannot afford to discard knowledge of what has gone before or what is now going on in his own trade and profession. If the printers of today do not wish to be esteemed arrogant when they term this calling of theirs an art, they must be willing, and show that they are willing, to subject it to such laws as have made its sister arts so free. All those who are concerned in what are accepted as the fine arts, the learned sciences, and the professions surround themselves with the history, literature, and concrete examples of the work with which they are particularly

12345 abcdefghijklmnopqrstuvwxyz 67890\$  
ABCDEF GHIJKLMNOPQRSTUVWXYZ  
ABCDEF GHIJKLMNOPQRSTUVWXYZ  
12345 abcdefghijklmnopqrstuvwxyz 67890\$  
ABCDEF GHIJKLMNOPQRSTUVWXYZ

11 Point No. 15E, 11 Set

### MONOTYPE FACES

The very best kind of originality is that which comes after a thorough apprenticeship; that which shall prove to be the blending of a firm conception of all useful precedent and the progressive tendencies of an able mind. For, let a man be as able and original as he may, he cannot afford to discard knowledge of what has gone before or what is now going on in his own trade and profession. If the printers of today do not wish to be esteemed arrogant when they term this calling of theirs an art, they must be willing, and show that they are willing, to subject it to such laws as have made its sister arts so free. All those concerned in what are accepted as the fine arts, the

12345 abcdefghijklmnopqrstuvwxyz 67890\$  
ABCDEF GHIJKLMNOPQRSTUVWXYZ  
ABCDEF GHIJKLMNOPQRSTUVWXYZ  
12345 abcdefghijklmnopqrstuvwxyz 67890\$  
ABCDEF GHIJKLMNOPQRSTUVWXYZ

12 Point No. 15E, 12 Set

### MONOTYPE FACES

The best kind of originality is that which comes after a sound apprenticeship; that which shall prove to be the blending of a firm conception of all useful precedent and the progressive tendencies of an able mind. For, let any man be as able and original as he may, he cannot afford to discard knowledge of what has gone before or what is now going on in his own trade and profession. If the printers of today do not wish to be esteemed arrogant when they term this calling of theirs an art, they must be willing, and show that they are willing, to subject it to such laws

12345 abcdefghijklmnopqrstuvwxyz 67890\$  
ABCDEF GHIJKLMNOPQRSTUVWXYZ  
ABCDEF GHIJKLMNOPQRSTUVWXYZ  
12345 abcdefghijklmnopqrstuvwxyz 67890\$  
ABCDEF GHIJKLMNOPQRSTUVWXYZ

### MONOTYPE FACES

The best kind of originality is that which comes after a sound apprenticeship; that which shall prove to be the blending of a firm conception of all useful precedent and the progressive tendencies of an able mind. For, let any man be as able and original as he may, he cannot afford to discard knowledge of what has gone before or what is now going on in his own trade and profession. If the printers of today do not wish to be esteemed arrogant when they term this calling of theirs an art, they must be willing, and show that they are willing, to subject it to such laws as have made its sister arts so free. When those concerned in what are accepted as the

# No. 16E. Book Arrangement C

## Composition Matrices

### 6 Point No. 16E, 7 Set

#### MONOTYPE FACES

The best kind of originality is that which comes after a sound apprenticeship; that which shall prove itself to be the blending of a firm conception of useful precedent and the progressive tendencies of an able mind. For, let a man be as able and original as he may, he cannot afford to discard knowledge of what has gone before or what is now going on in his own trade and profession. If the printers of today do not wish to be esteemed arrogant when they term this calling of theirs an art, they must be willing, and must show that they are willing to subject it to such laws as have made its sister arts so free. All those concerned in what are accepted as the fine arts, the learned sciences, and professions surround themselves with the history, literature, and concrete examples of the work with which they are particularly engaged. Yet it is only in very rare instances that such an atmosphere, with its material appurtenances, is to be found in the printing office. Art does not flourish in the hidden places, nor under restraint, nor in ignorance of what talent and genius have accomplished and are accomplishing throughout the world. For to follow precedent wisely does not mean to imitate slavishly one great exemplar, but to study all the masters faithfully, letting their great achievements sink slowly into the mind in order that we may patiently derive from the richness of our acquired knowledge and organized system an attitude of our own. The sprightly minded young man, who with his first business breath projects the new and startling, inevitably becomes tiresome, and is driven to avoid mistakes as in evolving brilliant schemes wherewith to dazzle his contemporaries. The best kind of originality is that which comes after a sound apprenticeship; that which shall prove itself to be the blending of a firm conception of all useful precedent and the progressive tendencies of an able mind. For, let any man be as able and original as he

|       |                            |         |
|-------|----------------------------|---------|
| 12345 | abcdefghijklmnopqrstuvwxy  | 67890\$ |
|       | ABCDEFGHIJKLMNopQRSTUVWXYZ |         |
|       | ABCDEFGHIJKLMNopQRSTUVWXYZ |         |
| 12345 | abcdefghijklmnopqrstuvwxy  | 67890\$ |
|       | ABCDEFGHIJKLMNopQRSTUVWXYZ |         |

### 8 Point No. 16E, 8 1/2 Set

#### MONOTYPE FACES

The best kind of originality is that which comes after a sound apprenticeship; that which shall prove to be the blending of a firm conception of all useful precedent and the progressive tendencies of an able mind. For, let a man be as able and original as he may, he cannot afford to discard knowledge of what has gone before or what is now going on in his own trade and profession. If the printers of today do not wish to be esteemed arrogant when they term this calling of theirs an art, they must be willing, and show that they are willing, to subject it to such laws as have made its sister arts so free. All those concerned in what are accepted as the fine arts, the learned sciences, and the professions surround themselves with the history, the literature, and concrete examples of the work with which they are particularly engaged. Yet it is only in very rare instances that such an atmosphere, with its material appurtenances, is to be found in a printing office. Art does not flourish in hidden places, nor under restraint, nor in ignorance of what talent and genius have accomplished and are now accomplishing throughout the world. For to follow all precedent wisely does not mean to imitate slavishly one great exemplar, but to study all masters faithfully, letting their great achievements sink slowly into the mind in order that we may patiently derive from the richness of our acquired knowledge and organized system an attitude of our own. The sprightly minded young man, who with

|       |                            |         |
|-------|----------------------------|---------|
| 12345 | abcdefghijklmnopqrstuvwxy  | 67890\$ |
|       | ABCDEFGHIJKLMNopQRSTUVWXYZ |         |
|       | ABCDEFGHIJKLMNopQRSTUVWXYZ |         |
| 12345 | abcdefghijklmnopqrstuvwxy  | 67890\$ |
|       | ABCDEFGHIJKLMNopQRSTUVWXYZ |         |

### 7 Point No. 16E, 8 Set

#### MONOTYPE FACES

The best kind of originality is that which comes after a sound apprenticeship; that which shall prove to be the blending of a firm conception of all useful precedent and the progressive tendencies of an able mind. For, let a man be as able and original as he may, he cannot afford to discard knowledge of what has gone before or what is now going on in his own trade and profession. If the printers of today do not wish to be esteemed arrogant when they term this calling of theirs an art, they must be willing, and show that they are willing, to subject it to such laws as have made its sister arts so free. All those concerned in what are accepted as the fine arts, the learned sciences, and the professions surround themselves with the history, literature, and the concrete examples of the work with which they are particularly engaged. Yet it is only in rare instances that such an atmosphere, with its material appurtenances, is to be found in a printing office. Art does not flourish in hidden places, nor under restraint, nor in ignorance of what talent and genius have accomplished and are accomplishing throughout the world. For to follow precedent wisely does not mean to imitate slavishly one great exemplar, but to study all masters faithfully, letting their great achievements sink slowly into the mind in order that we may patiently derive from the richness of our acquired knowledge and from organized system an attitude of our own. The sprightly minded young man, who with his first business breath projects the new and startling, inevitably becomes tiresome, and is driven

|       |                            |         |
|-------|----------------------------|---------|
| 12345 | abcdefghijklmnopqrstuvwxy  | 67890\$ |
|       | ABCDEFGHIJKLMNopQRSTUVWXYZ |         |
|       | ABCDEFGHIJKLMNopQRSTUVWXYZ |         |
| 12345 | abcdefghijklmnopqrstuvwxy  | 67890\$ |
|       | ABCDEFGHIJKLMNopQRSTUVWXYZ |         |

### 9 Point No. 16E, 9 Set

#### MONOTYPE FACES

The best kind of originality is that which comes after a sound apprenticeship; that which shall prove to be the blending of a firm conception of all useful precedent and the progressive tendencies of an able mind. For, let a man be as able and original as he may, he cannot afford to discard knowledge of what has gone before or what is now going on in his own trade and profession. If the printers of today do not wish to be esteemed arrogant when they term this calling of theirs an art, they must be willing, and show that they are willing, to subject it to such laws as have made its sister arts so free. All those concerned in what are accepted as the fine arts, the learned sciences, and the professions surround themselves with the history, literature, and concrete examples of the work with which they are particularly engaged. Yet it is only in rare instances that such an atmosphere, with its material appurtenances, is to be found in a printing office. Art does not flourish in hidden places, nor under restraint, nor in ignorance of what talent and genius have accomplished and are accomplishing throughout the world. For to follow precedent wisely does not mean to imitate slavishly one great exemplar, but to study all masters faithfully,

|       |                            |         |
|-------|----------------------------|---------|
| 12345 | abcdefghijklmnopqrstuvwxy  | 67890\$ |
|       | ABCDEFGHIJKLMNopQRSTUVWXYZ |         |
|       | ABCDEFGHIJKLMNopQRSTUVWXYZ |         |
| 12345 | abcdefghijklmnopqrstuvwxy  | 67890\$ |
|       | ABCDEFGHIJKLMNopQRSTUVWXYZ |         |

# No. 16E. Book Arrangement C

## Composition Matrices

10 Point No. 16E, 10 Set

### MONOTYPE FACES

The best kind of originality is that which comes after a sound apprenticeship; that which shall prove to be the blending of a firm conception of all useful precedent and the progressive tendencies of an able mind. For, let a man be as able and original as he may, he cannot afford to discard knowledge of what has gone before or what is now going on in his own trade and profession. If the printers of today do not wish to be esteemed arrogant when they term this calling of theirs an art, they must be willing, and show that they are willing, to subject it to such laws as have made its sister arts so free. All those who are concerned in what are accepted as the fine arts, the learned sciences, and the professions surround themselves with the history, the literature, and *concrete examples of the work with which they are particularly engaged. Yet it is only in rare instances*

12345 abcdefghijklmnopqrstuvwxyz 67890\$  
ABCDEFGHIJKLMNOPQRSTUVWXYZ  
ABCDEFGHIJKLMNOPQRSTUVWXYZ  
12345 abcdefghijklmnopqrstuvwxyz 67890\$  
ABCDEFGHIJKLMNOPQRSTUVWXYZ

11 Point No. 16E, 11 Set

### MONOTYPE FACES

The best kind of originality is that which comes after a sound apprenticeship; that which shall prove to be the blending of a firm conception of all useful precedent and the progressive tendencies of an able mind. For, let a man be as able and original as he may, he cannot afford to discard knowledge of what has gone before or what is now going on in his own trade and profession. If the printers of today do not wish to be esteemed arrogant when they term this calling of theirs an art, they must be willing, and show that they are willing, to subject it to such laws as have made its sister arts so free. All those concerned in what are accepted as the fine arts, the learned sciences, and professions surround

12345 abcdefghijklmnopqrstuvwxyz 67890\$  
ABCDEFGHIJKLMNOPQRSTUVWXYZ  
ABCDEFGHIJKLMNOPQRSTUVWXYZ  
12345 abcdefghijklmnopqrstuvwxyz 67890\$  
ABCDEFGHIJKLMNOPQRSTUVWXYZ

12 Point No. 16E, 12 Set

### MONOTYPE FACES

The best kind of originality is that which comes after a sound apprenticeship; that which shall prove to be the blending of a firm conception of all useful precedent and the progressive tendencies of an able mind. For, let any man be as able and original as he may, he cannot afford to discard knowledge of what has gone before or what is now going on in his own trade and profession. If the printers of today do not wish to be esteemed arrogant when they term this calling of theirs an art, they must be willing, and show that they are willing, to subject it to such laws as

12345 abcdefghijklmnopqrstuvwxyz 67890\$  
ABCDEFGHIJKLMNOPQRSTUVWXYZ  
ABCDEFGHIJKLMNOPQRSTUVWXYZ  
12345 abcdefghijklmnopqrstuvwxyz 67890\$  
ABCDEFGHIJKLMNOPQRSTUVWXYZ

### MONOTYPE FACES

The best kind of originality is that which comes after a sound apprenticeship; that which shall prove to be the blending of a firm conception of all useful precedent and the progressive tendencies of an able mind. For, let any man be as able and original as he may, he cannot afford to discard knowledge of what has gone before or what is now going on in his own trade and profession. If the printers of today do not wish to be esteemed arrogant when they term this calling of theirs an art, they must be willing, and show that they are willing, to subject it to such laws as have made its sister arts so free. All those concerned in what are accepted as the

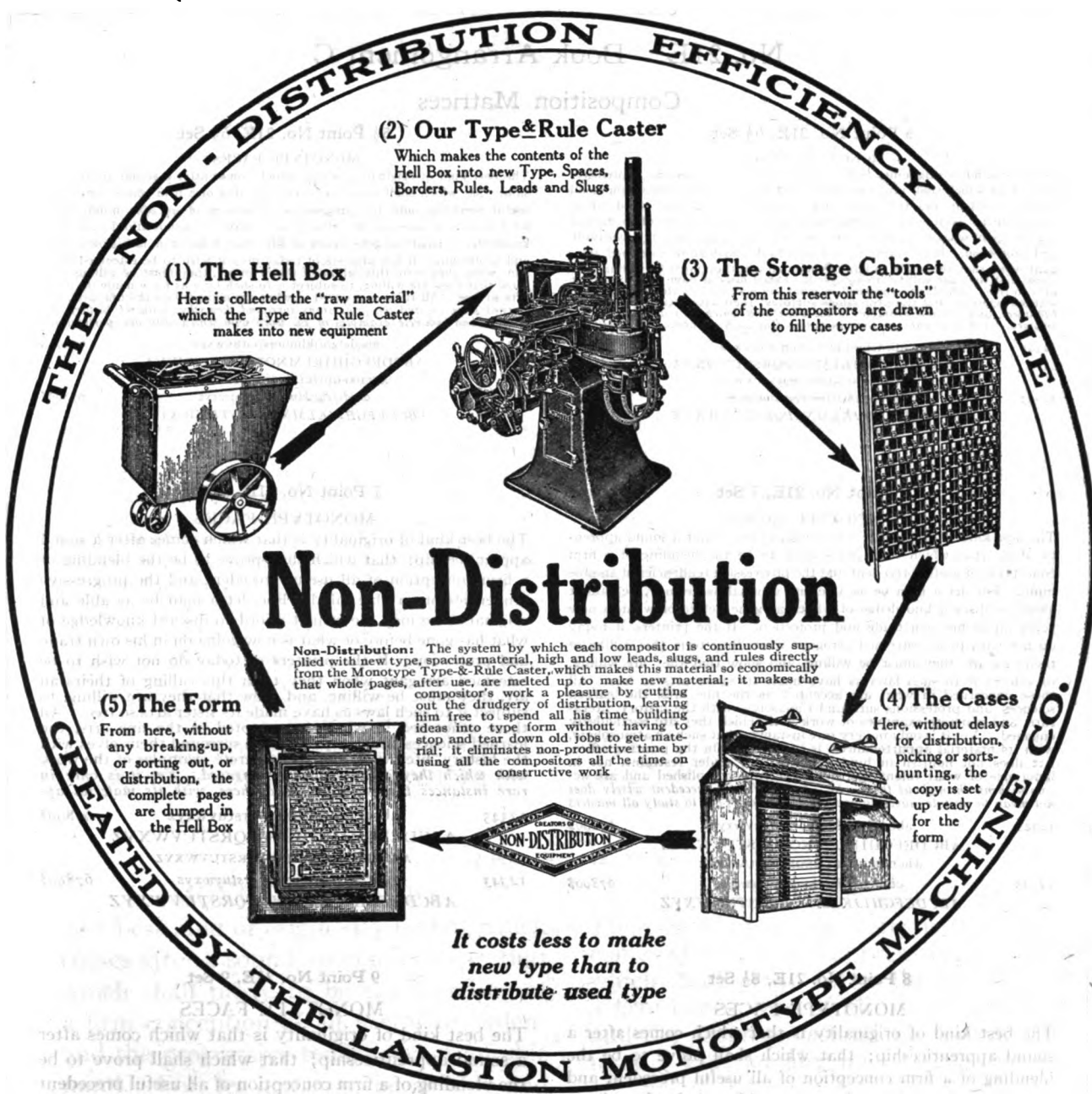

**No. 21E. Book Arrangement C  
Composition Matrices**

4½ Point No. 21E, 5½ Set

Left-hand column cast on 7-point body. Right-hand column cast on 5-point body

MONOTYPE FACES

The best kind of originality is that which comes after a sound apprenticeship; that which shall prove itself to be the blending of a firm conception of all useful precedent and the progressive tendencies of an able mind. For, let a man be as able and original as he may, he cannot afford to discard knowledge of what has gone before or what is now going on in his own trade and profession. If the printers of today do not wish to be esteemed arrogant when they term this calling of theirs an art, they must be willing, and show that they are willing, to subject it to such laws as have made its sister arts so free. All those concerned in what are accepted as the fine arts, the learned sciences, and professions surround themselves with the history, literature, and concrete examples of work with which they are

MONOTYPE FACES

The best kind of originality is that which comes after a sound apprenticeship; that which shall prove itself to be the blending of a firm conception of all useful precedent and the progressive tendencies of an able mind. For, let a man be as able and original as he may, he cannot afford to discard knowledge of what has gone before or what is now going on in his own trade and profession. If the printers of today do not wish to be esteemed arrogant when they term this calling of theirs an art, they must be willing, and show that they are willing, to subject it to such laws as have made its sister arts so free. All those concerned in what are accepted as the fine arts, the learned sciences, and professions surround themselves with the history, literature, and concrete examples of work with which they are particularly engaged. Yet it is only in very rare instances that such an atmosphere, with its material appurtenances, is to be found in the printing office. Art does not flourish in hidden places, nor under restraint, nor in ignorance of what talent and genius have accom-

12345

abcdefghijklmnopqrstuvwxyz  
ABCDEFGHIJKLMN O PQRSTU VWXYZ  
ABCDEFGHIJKLMN O PQRSTU VWXYZ

67890\$

12345

abcdefghijklmnopqrstuvwxyz  
ABCDEFGHIJKLMN O PQRSTU VWXYZ

67890\$

# No. 21E. Book Arrangement C

## Composition Matrices

### 5 Point No. 21E, 6½ Set

#### MONOTYPE FACES

The best kind of originality is that which comes after a sound apprenticeship; that which shall prove to be the blending of a firm conception of all useful precedent and the progressive tendencies of an able mind. For, let a man be as able and original as he may, he cannot afford to discard knowledge of what has gone before or what is now going on in his own trade and profession. If the printers of today do not wish to be esteemed arrogant when they term this calling of theirs an art, they must be willing, and show that they are willing, to subject it to such laws as have made its sister arts so free. All those concerned in what are accepted as the fine arts, the learned sciences, and the professions surround themselves with the history, literature, and concrete examples of the work with which they are particularly engaged. Yet it is only in rare instances that such an atmosphere, with its

12345      abcdefghijklmnopqrstuvwxyz      67890\$  
 ABCDEFGHIJKLMNOPQRSTUVWXYZ  
 ABCDEFGHIJKLMNOPQRSTUVWXYZ  
 12345      abcdefghijklmnopqrstuvwxyz      67890\$  
 ABCDEFGHIJKLMNOPQRSTUVWXYZ

### 6 Point No. 21E, 7 Set

#### MONOTYPE FACES

The best kind of originality is that which comes after a sound apprenticeship; that which shall prove itself to be the blending of a firm conception of useful precedent and the progressive tendencies of an able mind. For, let a man be as able and original as he may, he cannot afford to discard knowledge of what has gone before or what is now going on in his own trade and profession. If the printers of today do not wish to be esteemed arrogant when they term this calling of theirs an art, they must be willing, and show that they are willing, to subject it to such laws as have made its sister arts so free. All those concerned in what are accepted as the fine arts, the learned sciences, and professions surround themselves with the history, literature, and concrete examples of work with which they are particularly engaged. Yet it is only in very rare instances that such an atmosphere, with its material appurtenances, is to be found in the printing office. Art does not flourish in hidden places, nor under restraint, nor in ignorance of what talent and genius have accomplished and are accomplishing throughout the world. For to follow precedent wisely does not mean to imitate slavishly one great exemplar, but to study all masters

12345      abcdefghijklmnopqrstuvwxyz      67890\$  
 ABCDEFGHIJKLMNOPQRSTUVWXYZ  
 ABCDEFGHIJKLMNOPQRSTUVWXYZ  
 12345      abcdefghijklmnopqrstuvwxyz      67890\$  
 ABCDEFGHIJKLMNOPQRSTUVWXYZ

### 8 Point No. 21E, 8½ Set

#### MONOTYPE FACES

The best kind of originality is that which comes after a sound apprenticeship; that which shall prove to be the blending of a firm conception of all useful precedent and the progressive tendencies of an able mind. For, let a man be as able and original as he may, he cannot afford to discard knowledge of what has gone before or what is now going on in his own trade and profession. If the printers of today do not wish to be esteemed arrogant when they term this calling of theirs an art, they must be willing, and show that they are willing, to subject it to such laws as have made its sister arts so free. All those concerned in what are accepted as the fine arts, the learned sciences, and the professions surround themselves with the history, the literature, and concrete examples of the work with which they are particularly engaged. Yet it is only in very rare instances that such an atmosphere, with its material

12345      abcdefghijklmnopqrstuvwxyz      67890\$  
 ABCDEFGHIJKLMNOPQRSTUVWXYZ  
 ABCDEFGHIJKLMNOPQRSTUVWXYZ  
 12345      abcdefghijklmnopqrstuvwxyz      67890\$  
 ABCDEFGHIJKLMNOPQRSTUVWXYZ

### 5½ Point No. 21E, 6½ Set

#### MONOTYPE FACES

The best kind of originality is that which comes after a sound apprenticeship; that which shall prove to be the blending of a firm conception of all useful precedent and the progressive tendencies of an able mind. For, let a man be as able and as original as he may, he cannot afford to discard knowledge of what has gone before or what is now going on in his own trade and profession. If the printers of today do not wish to be esteemed arrogant when they term this calling of theirs an art, they must be willing, and show that they are willing, to subject it to such laws as have made its sister arts so free. All those concerned in what are accepted as the fine arts, the learned sciences, and the professions surround themselves with the history, literature, and concrete examples of the work with which they are particularly

12345      abcdefghijklmnopqrstuvwxyz      67890\$  
 ABCDEFGHIJKLMNOPQRSTUVWXYZ  
 ABCDEFGHIJKLMNOPQRSTUVWXYZ  
 12345      abcdefghijklmnopqrstuvwxyz      67890\$  
 ABCDEFGHIJKLMNOPQRSTUVWXYZ

### 7 Point No. 21E, 8 Set

#### MONOTYPE FACES

The best kind of originality is that which comes after a sound apprenticeship; that which shall prove to be the blending of a firm conception of all useful precedent and the progressive tendencies of an able mind. For, let a man be as able and original as he may, he cannot afford to discard knowledge of what has gone before or what is now going on in his own trade and profession. If the printers of today do not wish to be esteemed arrogant when they term this calling of theirs an art, they must be willing, and show that they are willing, to subject it to such laws as have made its sister arts so free. All those concerned in what are accepted as the fine arts, the learned sciences, and the professions surround themselves with the history, literature, and the concrete examples of the work with which they are particularly engaged. Yet it is only in rare instances that such an atmosphere, with its material ap-

12345      abcdefghijklmnopqrstuvwxyz      67890\$  
 ABCDEFGHIJKLMNOPQRSTUVWXYZ  
 ABCDEFGHIJKLMNOPQRSTUVWXYZ  
 12345      abcdefghijklmnopqrstuvwxyz      67890\$  
 ABCDEFGHIJKLMNOPQRSTUVWXYZ

### 9 Point No. 21E, 9 Set

#### MONOTYPE FACES

The best kind of originality is that which comes after a sound apprenticeship; that which shall prove to be the blending of a firm conception of all useful precedent and the progressive tendencies of an able mind. For, let a man be as able and original as he may, he cannot afford to discard knowledge of what has gone before or what is now going on in his own trade and profession. If the printers of today do not wish to be esteemed arrogant when they term this calling of theirs an art, they must be willing, and show that they are willing, to subject it to such laws as have made its sister arts so free. All those concerned in what are accepted as the fine arts, the learned sciences, and the professions surround themselves with the history, literature, and concrete

12345      abcdefghijklmnopqrstuvwxyz      67890\$  
 ABCDEFGHIJKLMNOPQRSTUVWXYZ  
 ABCDEFGHIJKLMNOPQRSTUVWXYZ  
 12345      abcdefghijklmnopqrstuvwxyz      67890\$  
 ABCDEFGHIJKLMNOPQRSTUVWXYZ

# No. 21E. Book Arrangement C

## Composition Matrices

10 Point No. 21E, 10½ Set

### MONOTYPE FACES

The best kind of originality is that which comes after a sound apprenticeship; that which shall prove to be the blending of a firm conception of all useful precedent and the progressive tendencies of an able mind. For, let a man be as able and original as he may, he cannot afford to discard knowledge of what has gone before or what is now going on in his own trade and profession. If the printers of today do not wish to be esteemed arrogant when they term this calling of theirs an art, they must be willing, and show that they are willing, to subject it to such laws as have made its sister arts so free. All those who are concerned in what are accepted as the fine arts, the learned sciences, and the professions surround themselves with the history, literature, and concrete examples of the work with which they are particularly engaged. *Yet it is only in rare instances that such an atmosphere, with its material*

12345 abcdefghijklmnopqrstuvwxyz 67890\$  
ABCDEFGHIJKLMN OPQRSTUVWXYZ

ABCDEFGHIJKLMN OPQRSTUVWXYZ

12345 abcdefghijklmnopqrstuvwxyz 67890\$  
ABCDEFGHIJKLMN OPQRSTUVWXYZ

11 Point No. 21E, 11½ Set

### MONOTYPE FACES

The best kind of originality is that which comes after a sound apprenticeship; that which shall prove to be the blending of a firm conception of all useful precedent and the progressive tendencies of an able mind. For, let a man be as able and original as he may, he cannot afford to discard knowledge of what has gone before or what is now going on in his own trade and profession. If the printers of today do not wish to be esteemed arrogant when they term this calling of theirs an art, they must be willing, and show that they are willing, to subject it to such laws as have made its sister arts so free. All those concerned in what are accepted as the fine arts, the learned sciences, and the professions surround themselves with the history, litera-

1234 abcdefghijklmnopqrstuvwxyz 567\$  
ABCDEFGHIJKLMN OPQRSTUVWXYZ

ABCDEFGHIJKLMN OPQRSTUVWXYZ

1234 abcdefghijklmnopqrstuvwxyz 567\$  
ABCDEFGHIJKLMN OPQRSTUVWXYZ

12 Point No. 21E, 12 Set

### MONOTYPE FACES

The best kind of originality is that which comes after a sound apprenticeship; that which shall prove to be the blending of a firm conception of all useful precedent and the progressive tendencies of an able mind. For, let any man be as able and original as he may, he cannot afford to discard knowledge of what has gone before or what is now going on in his own trade and profession. If the printers of today do not wish to be esteemed arrogant when they term this calling of theirs an art,

12345 abcdefghijklmnopqrstuvwxyz 67890\$  
ABCDEFGHIJKLMN OPQRSTUVWXYZ

ABCDEFGHIJKLMN OPQRSTUVWXYZ

12345 abcdefghijklmnopqrstuvwxyz 67890\$  
ABCDEFGHIJKLMN OPQRSTUVWXYZ

### MONOTYPE FACES

The best kind of originality is that which comes after a sound apprenticeship; that which shall prove to be the blending of a firm conception of all useful precedent and the progressive tendencies of an able mind. For, let any man be as able and original as he may, he cannot afford to discard knowledge of what has gone before or what is now going on in his own trade and profession. If the printers of today do not wish to be esteemed arrogant when they term this calling of theirs an art, they must be willing, and show that they are willing, to subject it to such laws



14 Point No. 21

**THE MONOTYPE STANDS FOR QUALITY**

At the same time Reducing Costs and Maintaining Prices that Leave  
Reasonable Profits for the Printer

**\$1234567890**

18 Point No. 21

**THE CONVERTIBLE MACHINE**

At first a Type Caster; add the Parts to set Matter in  
Justified Lines when you want to

**\$1234567890**

24 Point No. 21

**MONOTYPE LINE**

Means a Standard Line. Interchangeable  
for all Sizes and Faces

**\$1234567890**

30 Point No. 21

**A LABOR SAVING**

Profit Maker & Business Builder  
for the Progressive Printer

**\$1234567890**

36 Point No. 21

**SPACES AND QUADS**

Cast Easily from Old Metal

**\$1234567890**

# No. 221E. Book Arrangement C

## Composition Matrices

9 Point No. 221E, 9½ Set

### MONOTYPE FACES

The best kind of originality is that which comes after a sound apprenticeship; that which shall prove to be the blending of a firm conception of all useful precedent and the progressive tendencies of an able mind. For, let a man be as able and original as he may, he cannot afford to discard knowledge of what has gone before or what is now going on in his own trade and profession. If the printers of today do not wish to be esteemed arrogant when they term this calling of theirs an art, they must be willing, and show that they are willing, to subject it to such laws as have made its sister arts so free. All those who are concerned in what are accepted as the fine arts, the learned sciences, and the professions surround themselves with the history, the literature, and concrete examples of the work with which they may be particularly engaged. Yet it is only in very rare instances that such an atmos-

### MONOTYPE FACES

The best kind of originality is that which comes after a sound apprenticeship; that which shall prove to be the blending of a firm conception of all useful precedent and the progressive tendencies of an able mind. For, let a man be as able and original as he may, he cannot afford to discard knowledge of what has gone before or what is now going on in his own trade and profession. If the printers of today do not wish to be esteemed arrogant when they term this calling of theirs an art, they must be willing, and show that they are willing, to subject it to such laws as have made its sister arts so free. All those who are concerned in what are accepted as the fine arts, the learned sciences, and the professions surround themselves with the history, the literature, and concrete examples of the work with which they are particularly engaged. Yet it is only in very rare instances that such an atmosphere, with its material appurtenances, is to be found in the printing office. Art does not flourish in hidden places, nor under restraint, nor in ignorance of what talent and genius have accomplished and are accom-

12345 abcdefghijklmnopqrstuvwxyz 67890\$  
ABCDEFGHIJKLMNPOQRSTUVWXYZ  
ABCDEFGHIJKLMNPOQRSTUVWXYZ

12345 abcdefghijklmnopqrstuvwxyz 67890\$  
ABCDEFGHIJKLMNPOQRSTUVWXYZ

# No. 321E. Book Arrangement C

## Composition Matrices

5½ Point No. 321E, 7 Set

### MONOTYPE FACES

The best kind of originality is that which comes after a sound apprenticeship; that which shall prove itself to be the blending of a firm conception of useful precedent and the progressive tendencies of an able mind. For, let a man be as able and original as he may, he cannot afford to discard knowledge of what has gone before or what is now going on in his own trade and profession. If the printers of today do not wish to be esteemed arrogant when they term this calling of theirs an art, they must be willing, and show that they are willing, to subject it to such laws as have made its sister arts so free. All those concerned in what are accepted as the fine arts, the learned sciences, and professions surround themselves with the history, literature, and concrete examples of work with which they are particularly engaged. Yet it is only in very rare instances that such an atmosphere, with its material appurtenances, is to be found in the printing office. Art does not flourish in hidden places, nor under restraint, not in ignorance of what talent and genius have accomplished and are accomplishing throughout the world. For to follow precedent wisely does not mean to imitate slavishly one great exemplar, but to study all the masters faithfully, letting their great achievements sink slowly into the mind in order that we may patiently derive from the richness of our acquired knowledge and organized system an attitude of our own. The sprightly minded young man, who with his first business breath projects the new and startling, inevitably becomes tiresome, and is driven to an early disappearance; while the slower and more solidly endowed student will at least spend as much of his time in avoiding mistakes as in evolving brilliant schemes wherewith to dazzle his contemporaries. The best kind of originality is that which comes

### MONOTYPE FACES

The best kind of originality is that which comes after a sound apprenticeship; that which shall prove itself to be the blending of a firm conception of useful precedent and the progressive tendencies of an able mind. For, let a man be as able and original as he may, he cannot afford to discard knowledge of what has gone before or what is now going on in his own trade and profession. If the printers of today do not wish to be esteemed arrogant when they term this calling of theirs an art, they must be willing, and show that they are willing, to subject it to such laws as have made its sister arts so free. All those concerned in what are accepted as the fine arts, the learned sciences, and professions surround themselves with the history, literature, and concrete

12345 abcdefghijklmnopqrstuvwxyz 67890\$  
ABCDEFGHIJKLMNPOQRSTUVWXYZ  
ABCDEFGHIJKLMNPOQRSTUVWXYZ

12345 abcdefghijklmnopqrstuvwxyz 67890\$  
ABCDEFGHIJKLMNPOQRSTUVWXYZ

# No. 22E. Book Arrangement C

## Composition Matrices

6 Point No. 22E, 6½ Set

### MONOTYPE FACES

The best kind of originality is that which comes after a sound apprenticeship; that which shall prove to be the blending of a firm conception of all useful precedent and the progressive tendencies of an able mind. For, let a man be as able and original as he may, he cannot afford to discard knowledge of what has gone before or what is now going on in his own trade and profession. If the printers of today do not wish to be esteemed arrogant when they term this calling of theirs an art, they must be willing, and show that they are willing, to subject it to such laws as have made its sister arts so free. All those concerned in what are accepted as the fine arts, the learned sciences, and the professions surround themselves with the history, literature, and concrete examples of the work with which they are particularly engaged. Yet it is only in rare instances that such an atmosphere, with its material appurtenances, is to be found in a printing office. Art does not flourish in hidden places, nor under restraint, nor in ignorance of what talent and genius have accomplished and are accomplishing throughout the world. For to follow precedent wisely does not mean to imitate slavishly one great exemplar, but to study all masters faithfully, letting their great achievements sink slowly into the mind in order that we may patiently derive from the richness of our acquired knowledge and organized system an attitude of our own. The sprightly minded young man, who with his first business breath projects the new and startling, inevitably becomes tiresome, and is driven to an early disappearance; while the slower, more solidly endowed student will at least spend as much of his time in avoiding mistakes as in evolving brilliant schemes wherewith to dazzle his contemporaries. The best kind of originality is that which comes after a sound apprenticeship; that which shall prove to be the blending of a firm conception of all useful precedent and the progressive tendencies of an able mind. For, let any man be as able and original as he may, he cannot well afford to discard knowledge of what has gone before or what is now going on in his own trade and profession. If the printers of today do not wish to be esteemed arrogant when

|       |                            |         |
|-------|----------------------------|---------|
| 12345 | abcdefghijklmnopqrstuvwxy  | 67890\$ |
|       | ABCDEFGHIJKLMNOPQRSTUVWXYZ |         |
|       | abcdefghijklmnopqrstuvwxy  |         |
| 12345 | abcdefghijklmnopqrstuvwxy  | 67890\$ |
|       | ABCDEFGHIJKLMNOPQRSTUVWXYZ |         |

9 Point No. 22E, 9 Set

### MONOTYPE FACES

The best kind of originality is that which comes after a sound apprenticeship; that which shall prove to be the blending of a firm conception of all useful precedent and the progressive tendencies of an able mind. For, let a man be as able and original as he may, he cannot afford to discard knowledge of what has gone before or what is now going on in his own trade and profession. If the printers of today do not wish to be esteemed too arrogant when they term this calling of theirs an art, they must be willing, and show that they are willing, to subject it to such laws as have made its sister arts so free. All those concerned in what are accepted as the fine arts, the learned sciences, and the professions surround themselves with the history, the literature, and concrete examples of the work with which they may be particularly engaged. Yet it is only in rare instances that such an atmosphere, with its material appurtenances, is to be found in a printing office. Art does not flourish in hidden places, nor under restraint, nor in ignorance of what talent and genius have accomplished and are now accomplishing throughout the world. For to

|       |                            |         |
|-------|----------------------------|---------|
| 12345 | abcdefghijklmnopqrstuvwxy  | 67890\$ |
|       | ABCDEFGHIJKLMNOPQRSTUVWXYZ |         |
|       | abcdefghijklmnopqrstuvwxy  |         |
| 12345 | abcdefghijklmnopqrstuvwxy  | 67890\$ |
|       | ABCDEFGHIJKLMNOPQRSTUVWXYZ |         |

8 Point No. 22E, 8 Set

### MONOTYPE FACES

The best kind of originality is that which comes after a sound apprenticeship; that which shall prove to be the blending of a firm conception of all useful precedent and the progressive tendencies of an able mind. For, let a man be as able and original as he may, he cannot afford to discard knowledge of what has gone before or what is now going on in his own trade and profession. If the printers of today do not wish to be esteemed arrogant when they term this calling of theirs an art, they must be willing, and show that they are willing, to subject it to such laws as have made its sister arts so free. All those concerned in what are accepted as the fine arts, the learned sciences, and the professions surround themselves with the history, the literature, and concrete examples of the work with which they are particularly engaged. Yet it is only in rare instances that such an atmosphere with its material appurtenances, is to be found in a printing office. Art does not flourish in hidden places, nor under restraint, nor in ignorance of what talent and genius have accomplished and are accomplishing throughout the world. For to follow precedent wisely does not mean to imitate slavishly one great exemplar, but to study all masters faithfully, letting their great achievements sink slowly into the mind in order that we may patiently derive from

|       |                            |         |
|-------|----------------------------|---------|
| 12345 | abcdefghijklmnopqrstuvwxy  | 67890\$ |
|       | ABCDEFGHIJKLMNOPQRSTUVWXYZ |         |
|       | abcdefghijklmnopqrstuvwxy  |         |
| 12345 | abcdefghijklmnopqrstuvwxy  | 67890\$ |
|       | ABCDEFGHIJKLMNOPQRSTUVWXYZ |         |

10 Point No. 22E, 10 Set

### MONOTYPE FACES

The best kind of originality is that which comes after a sound apprenticeship; that which shall prove to be the blending of a firm conception of all useful precedent and the progressive tendencies of an able mind. For, let a man be as able and original as he may, he cannot afford to discard knowledge of what has gone before or what is now going on in his own trade and profession. If the printers of today do not wish to be esteemed arrogant when they term this calling of theirs an art, they must be willing, and show that they are willing, to subject it to such laws as have made its sister arts so free. All those who are concerned in what are accepted as the fine arts, the learned sciences, and the professions surround themselves with the history, the literature, and concrete examples of the work with which they are particularly engaged. Yet it is only in rare instances

|       |                            |         |
|-------|----------------------------|---------|
| 12345 | abcdefghijklmnopqrstuvwxy  | 67890\$ |
|       | ABCDEFGHIJKLMNOPQRSTUVWXYZ |         |
|       | abcdefghijklmnopqrstuvwxy  |         |
| 12345 | abcdefghijklmnopqrstuvwxy  | 67890\$ |
|       | ABCDEFGHIJKLMNOPQRSTUVWXYZ |         |

# No. 22E. Book Arrangement C

## Composition Matrices

11 Point No. 22E, 11 Set

### MONOTYPE FACES

The very best kind of originality is that which comes after a thorough apprenticeship; that which shall prove to be the blending of a firm conception of all useful precedent and the progressive tendencies of an able mind. For, let a man be as able and original as he may, he cannot afford to discard knowledge of what has gone before or what is now going on in his own trade and profession. If the printers of today do not wish to be esteemed arrogant when they term this calling of theirs an art, they must be willing, and show that they are willing, to subject it to such laws as have made its sister arts so free. All those concerned in what are accepted as the fine arts, the learned sciences, and the professions surround themselves with the history, the litera-

12345 abcdefghijklmnopqrstuvwxyz 67890\$

ABCDEFGHIJKLMN OPQRSTUVWXYZ

ABCDEFGHIJKLMN OPQRSTUVWXYZ

12345 abcdefghijklmnopqrstuvwxyz 67890\$

ABCDEFGHIJKLMN OPQRSTUVWXYZ

12 Point No. 22E, 12 Set

### MONOTYPE FACES

The best kind of originality is that which comes after a sound apprenticeship; that which shall prove to be the blending of a firm conception of all useful precedent and the progressive tendencies of an able mind. For, let a man be as able and original as he may, he cannot afford to discard knowledge of what has gone before or what is now going on in his own trade and profession. If the printers of today do not wish to be esteemed arrogant when they term this calling of theirs an art, they must be willing, and show *that they are willing, to subject it to such laws as have made all its sister arts so free.*

1234 abcdefghijklmnopqrstuvwxyz 567\$

ABCDEFGHIJKLMN OPQRSTUVWXYZ

ABCDEFGHIJKLMN OPQRSTUVWXYZ

1234 abcdefghijklmnopqrstuvwxyz 567\$

ABCDEFGHIJKLMN OPQRSTUVWXYZ

# No. 31E. Book Arrangement C

## Composition Matrices

6 Point No. 31E, 6½ Set

### MONOTYPE FACES

The best kind of originality is that which comes after a sound apprenticeship; that which shall prove to be the blending of a firm conception of all useful precedent and the progressive tendencies of an able mind. For, let a man be as able and original as he may, he cannot afford to discard knowledge of what has gone before or what is now going on in his own trade and profession. If the printers of today do not wish to be esteemed arrogant when they term this calling of theirs an art, they must be willing, and show that they are willing, to subject it to such laws as have made its sister arts so free. All those concerned in what are accepted as the fine arts, the learned sciences, and the professions surround themselves with the history, literature, and concrete examples of the work with which they are particularly engaged. Yet it is only in rare instances that such an atmosphere, with its material appurtenances, is to be found in a printing office. Art does not flourish in hidden places, nor under restraint, nor in ignorance of what talent and genius have accomplished and are accomplishing throughout the world. For to follow precedent wisely does not mean to imitate slavishly one great exemplar, but to study all masters faithfully, letting their great achievements sink slowly into the mind in order that we may patiently derive from the richness of our acquired knowledge and organized system an attitude of our own. The sprightly minded young man, who with his first business breath projects the new and startling, inevitably becomes tiresome, and is driven to an early disappearance; while the slower, more solidly endowed student will at least spend as much of his time in avoiding mistakes as in evolving brilliant schemes wherewith to dazzle his contemporaries. The best kind of originality is that which comes after a sound apprenticeship; that which shall prove to be the blending of a firm conception of all useful precedent and the progressive tendencies of an able mind. For, let any man be as able and original as he may, he cannot well afford to discard knowledge of what has gone before or what is now going on in his own trade and profession. If the printers of today do not wish to be esteemed arrogant when

|       |                              |         |
|-------|------------------------------|---------|
| 12345 | abcde fghijklmno pqrstuvwxyz | 67890\$ |
|       | ABCDEF GHIJKLMNOPQRSTU VWXYZ |         |
|       | ABCDEF GHIJKLMNOPQRSTU VWXYZ |         |
| 12345 | abcde fghijklmno pqrstuvwxyz | 67890\$ |
|       | ABCDEF GHIJKLMNOPQRSTU VWXYZ |         |

8 Point No. 31E, 8 Set

### MONOTYPE FACES

The best kind of originality is that which comes after a sound apprenticeship; that which shall prove to be the blending of a firm conception of all useful precedent and the progressive tendencies of an able mind. For, let a man be as able and original as he may, he cannot afford to discard knowledge of what has gone before or what is now going on in his own trade and profession. If the printers of today do not wish to be esteemed arrogant when they term this calling of theirs an art, they must be willing, and show that they are willing, to subject it to such laws as have made its sister arts so free. All those concerned in what are accepted as the fine arts, the learned sciences, and the professions surround themselves with the history, the literature, and concrete examples of the work with which they are particularly engaged. Yet it is only in rare instances that such an atmosphere, with its material appurtenances, is to be found in a printing office. Art does not flourish in hidden places, nor under restraint, nor in ignorance of what talent and genius have accomplished and are accomplishing throughout the world. For to follow precedent wisely does not mean to imitate slavishly one great exemplar, but to study all masters faithfully, letting their great achievements sink slowly into the mind in order that we may patiently derive from the richness of our acquired knowledge and organized system an attitude of our own. The sprightly minded young man,

|       |                              |         |
|-------|------------------------------|---------|
| 12345 | abcde fghijklmno pqrstuvwxyz | 67890\$ |
|       | ABCDEF GHIJKLMNOPQRSTU VWXYZ |         |
|       | ABCDEF GHIJKLMNOPQRSTU VWXYZ |         |
| 12345 | abcde fghijklmno pqrstuvwxyz | 67890\$ |
|       | ABCDEF GHIJKLMNOPQRSTU VWXYZ |         |

7 Point No. 31E, 7½ Set

### MONOTYPE FACES

The best kind of originality is that which comes after a sound apprenticeship; that which shall prove itself to be the blending of a firm conception of useful precedent and the progressive tendencies of an able mind. For, let a man be as able and original as he may, he cannot afford to discard knowledge of what has gone before or what is now going on in his own trade and profession. If the printers of today do not wish to be esteemed arrogant, when they term this calling of theirs an art, they must be willing, and show that they are willing, to subject it to such laws as have made its sister arts so free. All those concerned in what are accepted as the fine arts, the learned sciences, and professions surround themselves with the history, literature, and concrete examples of work with which they are particularly engaged. Yet it is only in very rare instances that such an atmosphere, with its material appurtenances, is to be found in the printing office. Art does not flourish in hidden places, nor under restraint, nor in ignorance of what talent and genius have accomplished and are accomplishing throughout the world. For to follow precedent wisely does not mean to imitate slavishly one great exemplar, but to study all masters faithfully, letting their great achievements sink slowly into the mind in order that we may patiently derive from the richness of our acquired knowledge and organized system an attitude of our own. The sprightly minded young man, who with his first business breath projects the new and startling, inevitably becomes tiresome, and is driven to an early disappearance; while the slower and more solidly endowed student will at least spend as much of his time in avoiding mistakes as in evolving brilliant schemes wherewith to dazzle

|       |                              |         |
|-------|------------------------------|---------|
| 12345 | abcde fghijklmno pqrstuvwxyz | 67890\$ |
|       | ABCDEF GHIJKLMNOPQRSTU VWXYZ |         |
|       | ABCDEF GHIJKLMNOPQRSTU VWXYZ |         |
| 12345 | abcde fghijklmno pqrstuvwxyz | 67890\$ |
|       | ABCDEF GHIJKLMNOPQRSTU VWXYZ |         |

9 Point No. 31E, 8½ Set

### MONOTYPE FACES

The best kind of originality is that which comes after a sound apprenticeship; that which shall prove to be the blending of a firm conception of all useful precedent and the progressive tendencies of an able mind. For, let a man be as able and original as he may, he cannot afford to discard knowledge of what has gone before or what is now going on in his own trade and profession. If the printers of today do not wish to be esteemed too arrogant when they term this calling of theirs an art, they must be willing, and show that they are willing, to subject it to such laws as have made its sister arts so free. All those concerned in what are accepted as the fine arts, the learned sciences, and professions surround themselves with the history, the literature, and concrete examples of the work with which they are more particularly engaged. Yet it is only in rare instances that such an atmosphere, with its material appurtenances, is to be found in a printing office. Art does not flourish in hidden places, nor under restraint, nor even in ignorance of what talent and genius have accomplished and are accomplishing throughout the world. For to follow precedent wisely does not mean to

|       |                              |         |
|-------|------------------------------|---------|
| 12345 | abcde fghijklmno pqrstuvwxyz | 67890\$ |
|       | ABCDEF GHIJKLMNOPQRSTU VWXYZ |         |
|       | ABCDEF GHIJKLMNOPQRSTU VWXYZ |         |
| 12345 | abcde fghijklmno pqrstuvwxyz | 67890\$ |
|       | ABCDEF GHIJKLMNOPQRSTU VWXYZ |         |

# No. 31E. Book Arrangement C

## Composition Matrices

10 Point No. 31E, 9½ Set

### MONOTYPE FACES

The best kind of originality is that which comes after a sound apprenticeship; that which shall prove to be the blending of a firm conception of all useful precedent and the progressive tendencies of an able mind. For, let a man be as able and original as he may, he cannot afford to discard knowledge of what has gone before or what is now going on in his own trade and profession. If the printers of today do not wish to be esteemed arrogant when they term this calling of theirs an art, they must be willing, and show that they are willing, to subject it to such laws as have made its sister arts so free. All those concerned in what are accepted as the fine arts, the learned sciences, and the professions surround themselves with the history, the literature, and concrete examples of the work with which they are particularly engaged. *Yet it is only in rare instances that such an*

12345 abcdefghijklmnopqrstuvwxyz 67890\$

ABCDEFGHIJKLMNOPQRSTUVWXYZ

ABCDEFGHIJKLMNOPQRSTUVWXYZ

12345 abcdefghijklmnopqrstuvwxyz 67890\$

ABCDEFGHIJKLMNOPQRSTUVWXYZ

11 Point No. 31E, 10½ Set

### MONOTYPE FACES

The best kind of originality is that which comes after a sound apprenticeship; that which shall prove to be the blending of a firm conception of all useful precedent and the progressive tendencies of an able mind. For, let a man be as able and original as he may, he cannot afford to discard knowledge of what has gone before or what is now going on in his own trade and profession. If the printers of today do not wish to be esteemed arrogant when they term this calling of theirs an art, they must be willing, and show that they are willing, to subject it to such laws as have made its sister arts so free. All those concerned in what are accepted as the fine arts, the learned sciences, and the professions surround them-

12345 abcdefghijklmnopqrstuvwxyz 67890\$

ABCDEFGHIJKLMNOPQRSTUVWXYZ

ABCDEFGHIJKLMNOPQRSTUVWXYZ

12345 abcdefghijklmnopqrstuvwxyz 67890\$

ABCDEFGHIJKLMNOPQRSTUVWXYZ

12 Point No. 31E, 11 Set

### MONOTYPE FACES

The very best kind of originality is that which comes after a thorough apprenticeship; that which shall prove to be the blending of a firm conception of all useful precedent and the progressive tendencies of an able mind. For, let a man be as able and original as he may, he cannot afford to discard knowledge of what has gone before or what is now going on in his own trade and profession. If the printers of today do not wish to be esteemed too arrogant when they term this calling of theirs an art, they must be willing, and show that they are willing, to subject it to such laws as have made its sister arts so free. All those

12345 abcdefghijklmnopqrstuvwxyz 67890\$

ABCDEFGHIJKLMNOPQRSTUVWXYZ

ABCDEFGHIJKLMNOPQRSTUVWXYZ

12345 abcdefghijklmnopqrstuvwxyz 67890\$

ABCDEFGHIJKLMNOPQRSTUVWXYZ

### MONOTYPE FACES

The very best kind of originality is that which comes after a thorough apprenticeship; that which shall prove to be the blending of a firm conception of all useful precedent and the progressive tendencies of an able mind. For, let a man be as able and original as he may, he cannot afford to discard knowledge of what has gone before or what is now going on in his own trade and profession. If the printers of today do not wish to be esteemed too arrogant when they term this calling of theirs an art, they must be willing, and show that they are willing, to subject it to such laws as have made its sister arts so free. All those concerned in what are accepted as the fine arts, the learned sciences, and the pro-

# No. 37E. Book Arrangement C

## Composition Matrices

6 Point No. 37E, 6½ Set

### MONOTYPE FACES

The best kind of originality is that which comes after a sound apprenticeship; that which shall prove to be the blending of a firm conception of all useful precedent and the progressive tendencies of an able mind. For, let a man be as able and original as he may, he cannot afford to discard knowledge of what has gone before or what is now going on in his own trade and profession. If the printers of today do not wish to be esteemed arrogant when they term this calling of theirs an art, they must be willing, and show that they are willing, to subject it to such laws as have made its sister arts so free. All those concerned in what are accepted as the fine arts, the learned sciences, and the professions surround themselves with the history, literature, and concrete examples of the work with which they are particularly engaged. Yet it is only in rare instances that such an atmosphere, with its material appurtenances, is to be found in a printing office. Art does not flourish in hidden places, nor under restraint, nor in ignorance of what talent and genius have accomplished and are accomplishing throughout the world. For to follow precedent wisely does not mean to imitate slavishly one great exemplar, but to study all masters faithfully, letting their great achievements sink slowly into the mind in order that we may patiently derive from the richness of our acquired knowledge and organized system an attitude of our own. The sprightly minded young man, who with his first business breath projects the new and startling, inevitably becomes tiresome, and is driven to an early disappearance; while the slower, more solidly endowed student will at least spend as much of his time in avoiding mistakes as in evolving brilliant schemes wherewith to dazzle his contemporaries. The best kind of originality is that which comes after a sound apprenticeship; that which shall prove to be the blending of a firm conception of all useful precedent and the progressive tendencies of an able mind. For, let any man be as able and original as he may, he cannot well afford to discard knowledge of what has gone before or what is now going on in his own trade and profession. If the printers of today do not wish to be esteemed arrogant when

|       |                            |         |
|-------|----------------------------|---------|
| 12345 | abcdefghijklmnopqrstuvwxy  | 67890\$ |
|       | ABCDEFGHIJKLMNOPQRSTUVWXYZ |         |
|       | abcdefghijklmnopqrstuvwxy  |         |
| 12345 | abcdefghijklmnopqrstuvwxy  | 67890\$ |
|       | ABCDEFGHIJKLMNOPQRSTUVWXYZ |         |

8 Point No. 37E, 8 Set

### MONOTYPE FACES

The best kind of originality is that which comes after a sound apprenticeship; that which shall prove to be the blending of a firm conception of all useful precedent and the progressive tendencies of an able mind. For, let a man be as able and original as he may, he cannot afford to discard knowledge of what has gone before or what is now going on in his own trade and profession. If the printers of today do not wish to be esteemed arrogant when they term this calling of theirs an art, they must be willing, and show that they are willing, to subject it to such laws as have made its sister arts so free. All those concerned in what are accepted as the fine arts, the learned sciences, and the professions surround themselves with the history, the literature, and concrete examples of the work with which they are particularly engaged. Yet it is only in rare instances that such an atmosphere, with its material appurtenances, is to be found in a printing office. Art does not flourish in hidden places, nor under restraint, nor in ignorance of what talent and genius have accomplished and are accomplishing throughout the world. For to follow precedent wisely does not mean to imitate slavishly one great exemplar, but to study all masters faithfully, letting their great achievements sink slowly into the mind in order that we may patiently derive from the richness of our acquired knowledge and organized system an attitude of our own. The sprightly minded young

|       |                            |         |
|-------|----------------------------|---------|
| 12345 | abcdefghijklmnopqrstuvwxy  | 67890\$ |
|       | ABCDEFGHIJKLMNOPQRSTUVWXYZ |         |
|       | abcdefghijklmnopqrstuvwxy  |         |
| 12345 | abcdefghijklmnopqrstuvwxy  | 67890\$ |
|       | ABCDEFGHIJKLMNOPQRSTUVWXYZ |         |

7 Point No. 37E, 7½ Set

### MONOTYPE FACES

The best kind of originality is that which comes after a sound apprenticeship; that which shall prove itself to be the blending of a firm conception of useful precedent and the progressive tendencies of an able mind. For, let a man be as able and original as he may, he cannot afford to discard knowledge of what has gone before or what is now going on in his own trade and profession. If the printers of today do not wish to be esteemed arrogant when they term this calling of theirs an art, they must be willing, and show that they are willing, to subject it to such laws as have made its sister arts so free. All those concerned in what are accepted as the fine arts, the learned sciences, and professions surround themselves with the history, literature, and concrete examples of work with which they are particularly engaged. Yet it is only in very rare instances that such an atmosphere, with its material appurtenances, is to be found in the printing office. Art does not flourish in hidden places, nor under restraint, nor in ignorance of what talent and genius have accomplished and are accomplishing throughout the world. For to follow precedent wisely does not mean to imitate slavishly one great exemplar, but to study all masters faithfully, letting their great achievements sink slowly into the mind in order that we may patiently derive from the richness of our acquired knowledge and organized system an attitude of our own. The sprightly minded young man, who with his first business breath projects the new and startling, inevitably becomes tiresome, and is driven to an early disappearance; while the slower and more solidly endowed student will at least spend as much of his time in avoiding mistakes as in evolving brilliant schemes wherewith to dazzle

|       |                            |         |
|-------|----------------------------|---------|
| 12345 | abcdefghijklmnopqrstuvwxy  | 67890\$ |
|       | ABCDEFGHIJKLMNOPQRSTUVWXYZ |         |
|       | abcdefghijklmnopqrstuvwxy  |         |
| 12345 | abcdefghijklmnopqrstuvwxy  | 67890\$ |
|       | ABCDEFGHIJKLMNOPQRSTUVWXYZ |         |

9 Point No. 37E, 9 Set

### MONOTYPE FACES

The best kind of originality is that which comes after a sound apprenticeship; that which shall prove to be the blending of a firm conception of all useful precedent and the progressive tendencies of an able mind. For, let a man be as able and original as he may, he cannot afford to discard knowledge of what has gone before or what is now going on in his own trade and profession. If the printers of today do not wish to be esteemed arrogant when they term this calling of theirs an art, they must be willing, and show that they are willing, to subject it to such laws as have made its sister arts so free. All those concerned in what are accepted as the fine arts, the learned sciences, and the professions surround themselves with the history, literature, and concrete examples of the work with which they are particularly engaged. Yet it is only in rare instances that such an atmosphere, with its material appurtenances, is to be found in a printing office. Art does not flourish in hidden places, nor under restraint, nor in ignorance of what talent and genius have accomplished and are accomplishing throughout the world. For to follow

|       |                            |         |
|-------|----------------------------|---------|
| 12345 | abcdefghijklmnopqrstuvwxy  | 67890\$ |
|       | ABCDEFGHIJKLMNOPQRSTUVWXYZ |         |
|       | abcdefghijklmnopqrstuvwxy  |         |
| 12345 | abcdefghijklmnopqrstuvwxy  | 67890\$ |
|       | ABCDEFGHIJKLMNOPQRSTUVWXYZ |         |

# No. 37E. Book Arrangement C

## Composition Matrices

10 Point No. 37E, 10 Set

### MONOTYPE FACES

The best kind of originality is that which comes after a sound apprenticeship; that which shall prove to be the blending of a firm conception of all useful precedent and the progressive tendencies of an able mind. For, let a man be as able and original as he may, he cannot afford to discard knowledge of what has gone before or what is now going on in his own trade and profession. If the printers of today do not wish to be esteemed arrogant when they term this calling of theirs an art, they must be willing, and show that they are willing, to subject it to such laws as have made its sister arts so free. All those who are concerned in what are accepted as the fine arts, the learned sciences, and the professions surround themselves with the history, literature, and concrete examples of the work with which they are particularly

12345 abcdefghijklmnopqrstuvwxyz 67890\$

ABCDEFGHIJKLMN OPQRSTUVWXYZ

ABCDEFGHIJKLMN OPQRSTUVWXYZ

12345 abcdefghijklmnopqrstuvwxyz 67890\$

ABCDEFGHIJKLMN OPQRSTUVWXYZ

11 Point No. 37E, 11 Set

### MONOTYPE FACES

The very best kind of originality is that which comes after a thorough apprenticeship; that which shall prove to be the blending of a firm conception of all useful precedent and the progressive tendencies of an able mind. For, let a man be as able and original as he may, he cannot afford to discard knowledge of what has gone before or what is now going on in his own trade and profession. If the printers of today do not wish to be esteemed arrogant when they term this calling of theirs an art, they must be willing, and show that they are willing, to subject it to such laws as have made its sister arts so free. All those concerned in what are accepted as the fine arts, the

12345 abcdefghijklmnopqrstuvwxyz 67890\$

ABCDEFGHIJKLMN OPQRSTUVWXYZ

ABCDEFGHIJKLMN OPQRSTUVWXYZ

12345 abcdefghijklmnopqrstuvwxyz 67890\$

ABCDEFGHIJKLMN OPQRSTUVWXYZ

12 Point No. 37E, 12 Set

### MONOTYPE FACES

The best kind of originality is that which comes after a sound apprenticeship; that which shall prove to be the blending of a firm conception of all useful precedent and the progressive tendencies of an able mind. For, let any man be as able and original as he may, he cannot afford to discard knowledge of what has gone before or what is now going on in his own trade and profession. If the printers of today do not wish to be esteemed arrogant when they term this calling of theirs an art, they must be willing, and show that they are willing, to subject it to such laws as

12345 abcdefghijklmnopqrstuvwxyz 67890\$

ABCDEFGHIJKLMN OPQRSTUVWXYZ

ABCDEFGHIJKLMN OPQRSTUVWXYZ

12345 abcdefghijklmnopqrstuvwxyz 67890\$

ABCDEFGHIJKLMN OPQRSTUVWXYZ

### MONOTYPE FACES

The best kind of originality is that which comes after a sound apprenticeship; that which shall prove to be the blending of a firm conception of all useful precedent and the progressive tendencies of an able mind. For, let any man be as able and original as he may, he cannot afford to discard knowledge of what has gone before or what is now going on in his own trade and profession. If the printers of today do not wish to be esteemed arrogant when they term this calling of theirs an art, they must be willing, and show that they are willing, to subject it to such laws as have made its sister arts so free. All of those concerned in what are accepted as the



14 Point No. 37

**MONOTYPE SPEED OF PRODUCTION**

Makes Type so Cheaply that it Costs Less to Make New Type than to  
Distribute your Worn-out Foundry Faces  
\$1234567890

18 Point No. 37

**THE BEST AND THE CHEAPEST**

The only Machine with an Unmatched Record for Repeat  
Orders from Satisfied Customers  
\$1234567890

24 Point No. 37

**THE TYPE CASTER**

That Others Have Tried and are Trying  
to Imitate, but Without Success  
\$1234567890

30 Point No. 37

**QUALITY PAYS**

It is the Best and the Only Lever  
to Raise Your Prices  
\$1234567890

36 Point No. 37

**OUR TYPE CASTER**

Makes Type for the Cases  
\$1234567890

14 Point No. 371

**GOOD TYPOGRAPHIC DISPLAY**

*Of Value to the Advertiser, with Clear, Sharp Faces, is the Daily Product of the Versatile Monotype on Department Store Ads.*

**\$1234567890**

18 Point No. 371

**PROGRESSIVE DAILIES**

*All Use the Monotype to Set and Cast Department Store Ads. It Saves Time, Money and Worry*

**\$1234567890**

24 Point No. 371

**THIRTY-FIVE HUNDRED**

*Machines in Daily Use on All Kinds of Work all over the World*

**\$1234567890**

30 Point No. 371

**SUPERIORITY PROVED**

*By 38 per cent. Repeat Orders from our Satisfied Customers*

**\$1234567890**

36 Point No. 371

**BOOKS & CATALOGS**

*Cast on the Machine with Faces*

**\$1234567890**

# No. 137E. Book Arrangement C

## Composition Matrices

6 Point No. 137E, 6½ Set

### MONOTYPE FACES

The best kind of originality is that which comes after a sound apprenticeship; that which shall prove to be the blending of a firm conception of all useful precedent and the progressive tendencies of an able mind. For, let a man be as able and original as he may, he cannot afford to discard knowledge of what has gone before or what is now going on in his own trade and profession. If the printers of today do not wish to be esteemed arrogant when they term this calling of theirs an art, they must be willing, and show that they are willing, to subject it to such laws as have made its sister arts so free. All those concerned in what are accepted as the fine arts, the learned sciences, and the professions surround themselves with the history, literature, and concrete examples of the work with which they are particularly engaged. Yet it is only in rare instances that such an atmosphere, with its material appurtenances, is to be found in a printing office. Art does not flourish in hidden places, nor under restraint, nor in ignorance of what talent and genius have accomplished and are accomplishing throughout the world. For to follow precedent wisely does not mean to imitate slavishly one great exemplar, but to study all masters faithfully, letting their great achievements sink slowly into the mind in order that we may patiently derive from the richness of our acquired knowledge and organized system an attitude of our own. The sprightly minded young man, who with his first business breath projects the new and startling, inevitably becomes tiresome, and is driven to an early disappearance; while the slower, more solidly endowed student will at least spend as much of his time in avoiding mistakes as in evolving brilliant schemes wherewith to dazzle his contemporaries. The best kind of originality is that which comes after a sound apprenticeship; that which shall prove to be the blending of a firm conception of all useful precedent and the progressive tendencies of an able mind. For, let any man be as able and original as he may, he cannot well afford to discard knowledge of what has gone before or what is now going on in his own trade and profession. *If the printers of today do not wish to be esteemed arrogant when*

12345      abcdefghijklmnopqrstuvwxyz      67890\$  
 ABCDEFGHIJKLMNOPQRSTUVWXYZ  
 12345      abcdefghijklmnopqrstuvwxyz      67890\$  
 ABCDEFGHIJKLMNOPQRSTUVWXYZ

9 Point No. 137E, 9 Set

### MONOTYPE FACES

The best kind of originality is that which comes after a sound apprenticeship; that which shall prove to be the blending of a firm conception of all useful precedent and the progressive tendencies of an able mind. For, let a man be as able and original as he may, he cannot afford to discard knowledge of what has gone before or what is now going on in his own trade and profession. If the printers of today do not wish to be esteemed arrogant when they term this calling of theirs an art, they must be willing, and show that they are willing, to subject it to such laws as have made its sister arts so free. All those concerned in what are accepted as the fine arts, the learned sciences, and the professions surround themselves with the history, literature, and concrete examples of the work with which they are particularly engaged. Yet it is only in rare instances that such an atmosphere, with its material appurtenances, to be found in a printing office. Art does not flourish in hidden places, nor under restraint, nor in ignorance of what talent and genius have accomplished

12345      abcdefghijklmnopqrstuvwxyz      67890\$  
 ABCDEFGHIJKLMNOPQRSTUVWXYZ  
 ABCDEFGHIJKLMNOPQRSTUVWXYZ  
 12345      abcdefghijklmnopqrstuvwxyz      67890\$  
 ABCDEFGHIJKLMNOPQRSTUVWXYZ

8 Point No. 137E, 8 Set

### MONOTYPE FACES

The best kind of originality is that which comes after a sound apprenticeship; that which shall prove to be the blending of a firm conception of all useful precedent and the progressive tendencies of an able mind. For, let a man be as able and original as he may, he cannot afford to discard knowledge of what has gone before or what is now going on in his own trade and profession. If the printers of today do not wish to be esteemed arrogant when they term this calling of theirs an art, they must be willing, and show that they are willing, to subject it to such laws as have made its sister arts so free. All those concerned in what are accepted as the fine arts, the learned sciences, and the professions surround themselves with the history, the literature, and concrete examples of the work with which they are particularly engaged. Yet it is only in rare instances that such an atmosphere, with its material appurtenances, is to be found in a printing office. Art does not flourish in hidden places, nor under restraint, nor in ignorance of what talent and genius have accomplished and are accomplishing throughout the world. For to follow precedent wisely does not mean to imitate slavishly one great exemplar, but to study all masters faithfully, letting their great achievements sink slowly into the mind in order that we may patiently derive from

12345      abcdefghijklmnopqrstuvwxyz      67890\$  
 ABCDEFGHIJKLMNOPQRSTUVWXYZ  
 ABCDEFGHIJKLMNOPQRSTUVWXYZ  
 12345      abcdefghijklmnopqrstuvwxyz      67890\$  
 ABCDEFGHIJKLMNOPQRSTUVWXYZ

10 Point No. 137E, 10 Set

### MONOTYPE FACES

The best kind of originality is that which comes after a sound apprenticeship; that which shall prove to be the blending of a firm conception of all useful precedent and the progressive tendencies of an able mind. For, let a man be as able and original as he may he cannot afford to discard knowledge of what has gone before or what is now going on in his own trade and profession. If the printers of today do not wish to be esteemed arrogant when they term this calling of theirs an art, they must be willing, and show that they are willing, to subject it to such laws as have made its sister arts so free. All those who are concerned in what are accepted as the fine arts, the learned sciences, and the professions surround themselves with the history, the literature, and concrete examples of the work with which they are particularly engaged. Yet it is only in rare instances

12345      abcdefghijklmnopqrstuvwxyz      67890\$  
 ABCDEFGHIJKLMNOPQRSTUVWXYZ  
 ABCDEFGHIJKLMNOPQRSTUVWXYZ  
 12345      abcdefghijklmnopqrstuvwxyz      67890\$  
 ABCDEFGHIJKLMNOPQRSTUVWXYZ

# No. 137E. Book Arrangement C.

## Composition Matrices

11 Point No. 137E, 11 Set

### MONOTYPE FACES

The very best kind of originality is that which comes after a thorough apprenticeship; that which shall prove to be the blending of a firm conception of all useful precedent and the progressive tendencies of an able mind. For, let a man be as able and original as he may, he cannot afford to discard knowledge of what has gone before or what is now going on in his own trade and profession. If the printers of today do not wish to be esteemed arrogant when they term this calling of theirs an art, they must be willing, and show that they are willing, to subject it to such laws as have made its sister arts so free. All those concerned in what are accepted as the fine arts, the learned sciences, and professions surround

12345 abcdefghijklmnopqrstuvwxyz 67890\$  
ABCDEF GHIJKLMNOPQRSTUVWXYZ  
ABCDEF GHIJKLMNOPQRSTUVWXYZ  
12345 abcdefghijklmnopqrstuvwxyz 67890\$  
ABCDEF GHIJKLMNOPQRSTUVWXYZ

### MONOTYPE FACES

The very best kind of originality is that which comes after a thorough apprenticeship; that which shall prove to be the blending of a firm conception of all useful precedent and the progressive tendencies of an able mind. For, let a man be as able and original as he may, he cannot afford to discard knowledge of what has gone before or what is now going on in his own trade and profession. If the printers of today do not wish to be esteemed arrogant when they term this calling of theirs an art, they must be willing, and show that they are willing, to subject it to such laws as have made its sister arts so free. All those concerned in what are accepted as the fine arts, the learned sciences, and professions surround themselves with the history, literature, and concrete examples of work with which they are

12 Point No. 137E, 12 Set

### MONOTYPE FACES

The best kind of originality is that which comes after a sound apprenticeship; that which shall prove to be the blending of a firm conception of all useful precedent and the progressive tendencies of an able mind. For, let any man be as able and original as he may, he cannot afford to discard knowledge of what has gone before or what is now going on in his own trade and profession. If the printers of today do not wish to be esteemed arrogant when they term this calling of theirs an art,

12345 abcdefghijklmnopqrstuvwxyz 67890\$  
ABCDEF GHIJKLMNOPQRSTUVWXYZ  
ABCDEF GHIJKLMNOPQRSTUVWXYZ  
12345 abcdefghijklmnopqrstuvwxyz 67890\$  
ABCDEF GHIJKLMNOPQRSTUVWXYZ

### MONOTYPE FACES

The best kind of originality is that which comes after a sound apprenticeship; that which shall prove to be the blending of a firm conception of all useful precedent and the progressive tendencies of an able mind. For, let any man be as able and original as he may, he cannot afford to discard knowledge of what has gone before or what is now going on in his own trade and profession. If the printers of today do not wish to be esteemed arrogant when they term this calling of theirs an art, they must be willing, and show that they are willing, to subject it to such laws

# No. 216A. Book Arrangement C4

## Composition Matrices

8 Point No. 216A, 5½ Set

### MONOTYPE FACES

The best kind of originality is that which comes after a sound apprenticeship; that which shall prove to be the blending of a firm conception of all useful precedent and the progressive tendencies of an able mind. For, let a man be as able and original as he may, he cannot afford to discard knowledge of what has gone before or what is now going on in his own trade and profession. If the printers of today do not wish to be esteemed arrogant when they term this calling of theirs an art, they must be willing, and show that they are willing, to subject it to such laws as have made its sister arts so free. All these concerned in what are accepted as the fine arts, the learned sciences, and professions surround themselves with the history, literature, and concrete examples of the work with which they are particularly engaged. Yet it is only in rare instances that such an atmosphere, with its material appurtenances, is to be found in a printing office. Art does not flourish in hidden places, nor under restraint, nor in ignorance of what talent and genius have accomplished and are accomplishing throughout the world. For to follow precedent wisely does not mean to imitate slavishly one great exemplar, but to study all masters faithfully, letting their great achievements sink slowly into the mind in order that we may patiently derive from the richness of our acquired knowledge and organized system an attitude of our own. The sprightly minded young man, who with his first business breath projects the new and startling, inevitably becomes tiresome, and is driven to an early disappearance; while the slower, more solidly endowed student will at least spend as much of his time in avoiding mistakes as in evolving brilliant schemes wherewith to dazzle his contemporaries. The best kind of originality is that which comes after a sound apprenticeship; that which shall prove to be the blending of a firm conception of all useful precedent and the progressive tendencies of an able mind. For, let a man be as able and original as he may, he cannot afford to discard knowledge of what has gone before or what is now going on in his own trade and profession. If the printers of today do not wish to be esteemed arrogant when they term this calling of theirs an art, they must be willing, and show that they are willing, to subject it

### MONOTYPE FACES

The best kind of originality is that which comes after a sound apprenticeship; that which shall prove to be the blending of a firm conception of all useful precedent and the progressive tendencies of an able mind. For, let a man be as able and original as he may, he cannot afford to discard knowledge of what has gone before or what is now going on in his own trade and profession. If the printers of today do not wish to be esteemed arrogant when they term this calling of theirs an art, they must be willing, and show that they are willing, to subject it to such laws as have made its sister arts so free. All these concerned in what are accepted as the fine arts, the learned sciences, and professions surround themselves with the history, literature, and concrete examples of the work with which they are particularly engaged. Yet it is only in rare instances that such an atmosphere, with its material appurtenances, is to be found in a printing office. Art does not flourish in hidden places, nor under restraint, nor in ignorance of what talent and genius have accomplished and are accomplishing throughout the world. For to follow precedent wisely does not mean to imitate slavishly one great exemplar, but to study all masters faithfully, letting their great achievements sink slowly into the mind in order that we may patiently derive from the richness of our acquired knowledge and organized system an attitude of our own. The sprightly minded young man, who with his first business breath projects the new and startling, inevitably becomes tiresome, and is driven to an early disappearance; while the slower, more solidly endowed student will at least spend as much of his time in avoiding mistakes as in evolving brilliant schemes wherewith to dazzle his contemporaries. The best kind of originality is that which comes after a sound apprenticeship; that which shall prove to be the blending of a firm conception of all useful precedent and the progressive tendencies of an able mind. For, let a man be as able and original as he may, he cannot afford to discard knowledge of what has gone before or what is now going on in his own trade and profession. If the printers of today do not wish to be esteemed arrogant when they term this calling of theirs an art, they must be willing, and show that they are willing, to subject it to such laws as have made its sister arts so free. All these concerned in what are accepted as the fine arts, the learned sciences, and professions surround themselves with the history, literature, and concrete examples of the work with which they are particularly engaged. Yet it is only in rare instances that such an atmosphere, with its material appurtenances, is to be found in a printing office. Art does not flourish in hidden places, nor under restraint, nor in ignorance of what talent and genius have accomplished and are

abcdefghijklmnopqrstuvwxyz  
ABCDEFGHIJKLMNQRSTUWXYZ  
51234567890

# THE ORIGINAL OLD CASLON ON THE MONOTYPE

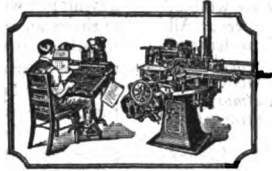

**T**HIS NEW MONOTYPE CASLON (the No. 337 Series) is a faithful reproduction of a face that has steadfastly maintained its popularity in spite of defilement by designers who have distorted this beautiful old face to suit the so-called "standard life" and in other ways endeavored to "modernize" a classic.

WE confidently rest our typographic reputation upon this real Caslon, for, although these matrices have been made in the cellular sizes from 7 to 12 point, for use on a composing machine, surely there is nothing "machinery" about the face here shown; all the charm of the original hand-cut letters has been preserved.

CASLON should be set leaded, and therefore we have made the face with its distinctive long descenders; for those who must set this face solid, almost a desecration, we have provided, in the cellular point sizes, matrices for the shortened descenders, but these are much less stubby than the descenders of most of the modern adaptations of this face.

ONE other point should be noted; Caslon was made to be printed upon hand-made paper—there was no machine-finish in those good old days. We have not attempted the impossible, to make a face that would be Caslon under totally different printing conditions.

WE have two other Caslons, the Nos. 37 and 137E Series; therefore we have made this new-old Caslon for our own satisfaction and to delight those who love to mix type, paper and brains. To show the great difference that paper makes in this face we here print it both on antique and on coated paper. *In ordering, please be sure to specify whether you wish the long or the short descenders.*

*A faithful reproduction of the real old Caslon Series cut in the year 1720, by William Caslon, the first, of London*

Fonts of Matrices of the No. 337 Series shown on these pages are sold at Class A prices  
NOT INCLUDED IN MATRIX LIBRARY AND WILL NOT BE LEASED

Composition Matrices

7 Point No. 337E, 7 1/2 Set

Monotype Standard Line

The best kind of originality is that which comes after a sound apprenticeship; that which shall prove itself to be the blending of a firm conception of useful precedent and the progressive tendencies of an able mind. For, let a man be as able and original as he may, he cannot afford to discard knowledge of what has gone before or what is now going on in his own trade and profession. If the printers of today do not wish to be esteemed arrogant when they term this calling of theirs an art, they must be willing, and show that they are willing, to subject it to such laws as have made its sister arts so free. All those concerned in what are accepted as the fine arts, the learned sciences, and professions surround themselves with the history, literature, and concrete examples of work with which they are particularly engaged. Yet it is only in very rare instances that such an atmosphere, with its material appurtenances, is to be found in the printing office.

12345 abcdefghijklmnopqrstuvwxyzæœøðþǿ 67890\$
ABCDEFGHIJKLMNPOQRSTUVWXYZ&Æ
ABCDEFghijklmnopqrstuvwxyzæœøðþǿ 67890\$
ABCDEFGHIJYKLMNOPQRSTTUVWXYZZ&Æ

7 Point No. 337E, 7 1/2 Set

With Long Descenders for 8-Point Body, Line Standard .075"

The best kind of originality is that which comes after a sound apprenticeship; that which shall prove itself to be the blending of a firm conception of useful precedent and the progressive tendencies of an able mind. For, let a man be as able and original as he may, he cannot afford to discard knowledge of what has gone before or what is now going on in his own trade and profession. If the printers of today do not wish to be esteemed arrogant when they term this calling of theirs an art, they must be willing, and show that they are willing, to subject it to such laws as have made its sister arts so free. All those concerned in what are accepted as the fine arts, the learned sciences, and professions surround themselves with the history, literature, and concrete examples of work with which they are particularly engaged. Yet it is only in very rare instances that such an atmosphere, with its material appurtenances, is to be found in a printing office. Art does not flourish in hidden places, nor under restraint, nor in ignorance of what talent and genius have accomplished and are accomplishing throughout the world. For to follow precedent wisely

JQgjpqy3579j@fgjppqyffiffiffi34579

These characters take the place of those in font at left

8 Point No. 337E, 8 Set

Monotype Standard Line

The best kind of originality is that which comes after a sound apprenticeship; that which shall prove itself to be the blending of a firm conception of useful precedent and the progressive tendencies of an able mind. For, let a man be as able and original as he may, he cannot afford to discard knowledge of what has gone before or what is now going on in his own trade and profession. If the printers of today do not wish to be esteemed arrogant when they term this calling of theirs an art they must be willing, and show that they are willing, to subject it to such laws as have made its sister arts so free. All those concerned in what are accepted as the fine arts, the learned sciences, and professions surround themselves with the history, literature,

12345 abcdefghijklmnopqrstuvwxyzæœøðþǿ 67890\$
ABCDEFGHIJKLMNPOQRSTUVWXYZ&Æ
ABCDEFghijklmnopqrstuvwxyzæœøðþǿ 67890\$
ABCDEFGHIJYKLMNOPQRSTTUVWXYZZ&Æ

8 Point No. 337E, 8 Set

With Long Descenders for 9-Point Body, Line Standard .085"

The best kind of originality is that which comes after a sound apprenticeship; that which shall prove itself to be the blending of a firm conception of useful precedent and the progressive tendencies of an able mind. For, let a man be as able and original as he may, he cannot afford to discard knowledge of what has gone before or what is now going on in his own trade and profession. If the printers of today do not wish to be esteemed arrogant when they term this calling of theirs an art, they must be willing, and show that they are willing, to subject it to such laws as have made its sister arts so free. All those concerned in what are accepted as the fine arts, the learned sciences, and professions surround themselves with the history, literature, and concrete examples of the work with which they are particularly engaged. Yet it is only in rare instances that such an atmosphere, with its material appurtenances, is to be

JQgjpqy3579j@fgjppqyffiffiffi34579.

These characters take the place of those in font at left

9 Point No. 337E, 9 Set

Monotype Standard Line

The best kind of originality is that which comes after a sound apprenticeship; that which shall prove itself to be the blending of a firm conception of useful precedent and the progressive tendencies of an able mind. For, let a man be as able and original as he may, he cannot afford to discard knowledge of what has gone before or what is now going on in his own trade and profession. If the printers of today do not wish to be esteemed arrogant when they term this calling of theirs an art, they must be willing, and show that they are willing, to subject it to

12345 abcdefghijklmnopqrstuvwxyzæœøðþǿ 67890\$
ABCDEFGHIJKLMNPOQRSTUVWXYZ&Æ
ABCDEFghijklmnopqrstuvwxyzæœøðþǿ 67890\$
ABCDEFGHIJYKLMNOPQRSTTUVWXYZZ&Æ

9 Point No. 337E, 9 Set

With Long Descenders for 10-Point Body, Line Standard .095"

The best kind of originality is that which comes after a sound apprenticeship; that which shall prove itself to be the blending of a firm conception of useful precedent and the progressive tendencies of an able mind. For, let a man be as able and original as he may, he cannot afford to discard knowledge of what has gone before or what is now going on in his own trade and profession. If the printers of today do not wish to be esteemed arrogant when they term this calling of theirs an art, they must be willing, and show that they are willing, to subject it to such laws as have made its sister arts so free. All those concerned in what are accepted as the fine arts, the learned sciences, and professions surround themselves with the history, literature, and concrete examples

JQgjpqy3579j@fgjppqyffiffiffi34579

These characters take the place of those in font at left

The left column shows this face with slightly shortened descenders on Standard Monotype Line. The right column, directly opposite, shows the same sizes with long descenders, conforming to the Original Caslon, cast on a body that is one point size larger, the body being lengthened below the Monotype line

# No. 337E. Book Arrangement C

## Composition Matrices

10 Point No. 337E, 10 Set  
Monotype Standard Line

The best kind of originality is that which comes after a sound apprenticeship; that which shall prove itself to be the blending of a firm conception of useful precedent and the progressive tendencies of an able mind. For, let a man be as able and original as he may, he cannot afford to discard knowledge of what has gone before or what is now going on in his own trade and profession. If the

12345 abcdefghijklmnopqrstuvwxyz 67890\$

ABCDEFGHIJKLMNPOQQRSTUVWXYZ

ABCDEFGHIJKLMNPOQQRSTUVWXYZ&Æ

12345 abcdefghijklmnopqrstuvwxyz 67890\$

ABCDEFGHIJKL MNOPQRSTUVWXYZ

11 Point No. 337E, 11 Set  
Monotype Standard Line

The best kind of originality is that which comes after a sound apprenticeship; that which shall prove itself to be the blending of a firm conception of useful precedent and the progressive tendencies of an able mind. For, let a man be as able and original as he may, he cannot afford to discard knowledge of what has gone before or

12345 abcdefghijklmnopqrstuvwxyz 67890\$

ABCDEFGHIJKLMNPOQQRSTUVWXYZ

ABCDEFGHIJKLMNPOQQRSTUVWXYZ&Æ

12345 abcdefghijklmnopqrstuvwxyzæ 67890\$

ABCDEFGHIJKL MNOPQRSTUVWXYZ

12 Point No. 337E, 12 Set  
Monotype Standard Line

The best kind of originality is that which comes after a sound apprenticeship; that which shall prove itself to be the blending of a firm conception of useful precedent and the progressive tendencies of an able mind. For, let a man be as able and orig-

12345 abcdefghijklmnopqrstuvwxyz 67890\$

ABCDEFGHIJKLMNPOQQRSTUVW

ABCDEFGHIJKLMNPOQQRSTUVWXYZ&

12345 abcdefghijklmnopqrstuvwxyz 67890\$

ABCDEFGHIJKL MNOPQRSTUVW

The left column shows this face with slightly shortened descenders on Standard Monotype Line. The right column, directly opposite, shows the same sizes with long descenders, conforming to the Original Caslon, cast on a body that is one point size larger, the body being lengthened below the Monotype line

10 Point No. 337E, 10 Set

With Long Descenders for 11-Point Body, Line Standard .105"

The best kind of originality is that which comes after a sound apprenticeship; that which shall prove itself to be the blending of a firm conception of useful precedent and the progressive tendencies of an able mind. For, let a man be as able and original as he may, he cannot afford to discard knowledge of what has gone before or what is now going on in his own trade and profession. If the printers of today do not wish to be esteemed arrogant when they term this calling of theirs an art, they must be willing, and show that they are willing, to subject it to such laws as have made its sister arts

JQjgpqy3579J2fgjppqyffiffiffi34579

These characters take the place of those in font at left

11 Point No. 337E, 11 Set

With Long Descenders for 12-Point Body, Line Standard .120"

The best kind of originality is that which comes after a sound apprenticeship; that which shall prove itself to be the blending of a firm conception of useful precedent and the progressive tendencies of an able mind. For, let a man be as able and original as he may, he cannot afford to discard knowledge of what has gone before or what is now going on in his own trade and profession. If the printers of today do not wish to be esteemed arrogant when they term this calling of theirs an art, they must be willing, and

JQjgpqy3579J2fgjppqyffiffiffi34579

These characters take the place of those in font at left

### How to Order

*Monotype Standard Line.*—All the characters shown in the left column of pages six and seven will be furnished in filling an order for Monotype Standard Line Matrices. This will include the regular font characters and the following six "different design" letters furnished as side sorts:

Q q & T T b

*Long Descenders.*—When an order is received for Long Descender Matrices, we will furnish all the characters shown in the left columns of pages six and seven, except that those shown in the right column will be substituted for the short descenders; making the font of the same number of characters as above and with the same extra six characters as side sorts:

Q q & T T b

*Combination Fonts* will include all the characters shown in both columns of pages six and seven; that is, in addition to the regular number of Standard Line characters in the font and the six "different design" characters, the Long Descender characters will also be furnished, making thirty-six additional matrices furnished as side sorts, as follows:

JQjgpqy3579J2fgjppqyffiffiffi34579 Q q & T T b



14 Point No. 337

HINTS ON DECORATIVE PRINTING

Summer of 1815 busy one for London Printers, Publishers and Bibliomaniacs  
Business was brisk with the Wood-Engravers, too

\$1234567890

18 Point No. 337

THE ANTIQUITIES OF BRITAIN

I may in Truth affirm that the Public had not before Gazed upon  
a Volume of more Singular Embellishments

\$1234567890

24 Point No. 337

ORIGINAL DECAMERON

In the Large Paper Copies, where the Paper is of  
Excellent Quality, the Effect

\$1234567890

30 Point No. 337

THE BIBLIOMANIACS

Two Hundred and Seventy Copies of an  
Elephantine Size for 10 cts.

\$1234567890

36 Point No. 337

ROYAL INSTITUTION

Improvements in Color Printing

\$1234567890

Fonts of Matrices of the No. 337 Series shown on these pages are sold at Class A prices  
NOT INCLUDED IN MATRIX LIBRARY AND WILL NOT BE LEASED

14 Point No. 3371

**THE CELEBRATED AMATEURS**

*In the little red House on the corner, at the sign of the Pillars of Hercules, was born  
May 7, 1699, Pierre-Jean Mariette, the illustrious*

\$1234567890

18 Point No. 3371

**NO IMAGINATION REQUIRED**

*To Picture the Ardent Lad turning over, day after day, the Great Sheets  
of Pictures in his Father's Portfolios*

\$1234567890

24 Point No. 3371

**PURSUING THE BEAUTIFUL**

*No Vulgar Passion permitted to Disturb the Serenity of  
this most Celebrated Amateur*

\$1234567890

30 Point No. 3371

**FINE WORKS OF ART**

*Admired by the Last Scion of One of those  
Ancient stocks of Feudal Bourgeois*

\$1234567890

36 Point No. 3371

**PIERRE-JEAN**

*Print Collector and an Amateur*

\$1234567890

A complete showing of Swash Characters for the above fonts of the No. 3371 Series are shown on the next page. The matrices for the Swash Characters are not included with the regular 81 character font, but are sold at regular Class A prices and must be ordered separately

Fonts of Matrices of the No. 337 Series shown on these pages are sold at Class A prices

NOT INCLUDED IN MATRIX LIBRARY AND WILL NOT BE LEASED

# SWASH CHARACTERS

*for the Monotype Old Caslon Series*

£

14 Point No. 3371

*A B C D E G K L M N P R U & Et k v w z*

18 Point No. 3371

*A B C D E G K L M N P R U & Et k v w z*

24 Point No. 3371

*A B C D E G K L M N P R U & Et k v w z*

30 Point No. 3371

*A B C D E G K L M N P R U  
& Et k v w z*

36 Point No. 3371

*A B C D E G K L M  
N P R U &  
Et k v w z*

£

CAUTION ON SWASH CHARACTERS: To cast the swash characters with the authentic close fitting, as originally designed by William Caslon the First, requires that the Molds and Type-pusher Guide be altered to clear the extra long swash kern. The Molds can be altered only in our factory and a nominal charge is made for this. The Type-pusher Guide can be altered by the customer from directions which we will furnish, or, if preferred, a new one may be purchased. Molds made since February 1, 1920, and Type-pusher Guides on machines number 6263 and following have these alterations. For machines of lower serial number than 1203, additional alterations may be necessary, details of which will be furnished when required.

# No. 79J. Job Arrangement C2

## Composition Matrices

5 Point No. 79J, 6½ Set

### MONOTYPE FACES

The best kind of originality is that which comes after a sound apprenticeship; that which shall prove to be the blending of a firm conception of all useful precedent and the progressive tendencies of an able mind. For, let a man be as able and original as he may, he cannot afford to discard knowledge of what has gone before or what is now going on in his own trade and profession. If the printers of today do not wish to be esteemed arrogant when they term this calling of theirs an art, they must be willing, and show that they are willing, to subject it to such laws as have made its sister arts so free. All those concerned in what are accepted as the fine arts, the learned sciences, and professions surround themselves with the history, literature, and concrete examples of the work with which they are engaged. Yet it is only in rare instances that such an atmosphere, with its material appurtenances, is to be found in a printing office. Art does not flourish in hidden places, nor under restraint, nor in ignorance of what talent and genius have accomplished and are now accomplishing throughout the world. For to follow precedent wisely does not mean to imitate slavishly one great exemplar, but to study all masters faithfully, letting their great achievements sink slowly into the mind in order that we may patiently derive from the richness of our acquired knowledge and organized system an attitude of our own. The sprightly minded young man, who with his first business breath projects the new and startling, inevitably becomes tiresome, and is driven to an early disappearance; while the slower, more solidly endowed student will at least spend as much of his time in avoiding mistakes as in evolving brilliant schemes wherewith to dazzle his contemporaries. The best kind of originality is that which comes after a sound apprenticeship; that which shall prove to be the blending of a firm conception of all useful precedent and the progressive tendencies of an able mind. For, let a man be as able and original as he may, he cannot afford to discard knowledge of what has gone before or what is now going on in his own trade and profession. If the printers of today do not wish to be esteemed arrogant when they term this calling of theirs an art, they must be willing, and show that they are willing, to subject it to just such laws as have made its sister arts so free. All those concerned in what are accepted as the fine arts, the learned sciences, and professions surround themselves with the history, the literature, and concrete examples of the work with which they are particularly engaged. Yet it is only in very rare instances that such an atmosphere, with its material appurtenances, is to be found in a printing office. Art does not flourish in hidden places, nor under restraint, nor in ignorance of what talent and genius have accomplished and are now accomplishing throughout the world. For to follow precedent wisely does not mean to imitate slavishly one great exemplar, but to study all masters faithfully, letting their great achievements sink slowly into the mind in order that we may patiently derive from the richness of our acquired knowledge and organized system an attitude of our own. The sprightly minded young man, who with his first business breath projects the new and startling, inevitably becomes tiresome, and is driven to an early disappearance; while the slower, more solidly endowed student will at least spend as much of his time in avoiding mistakes as in evolving brilliant schemes wherewith to dazzle his contemporaries. The best kind of originality is that which comes after a sound apprenticeship; that which shall prove to

abcdefghijklmnopqrstuvwxyz  
 ABCDEFGHIJKLMNOPQRSTUVWXYZ  
 \$123456789

7 Point No. 79J, 8 Set

### MONOTYPE FACES

The best kind of originality is that which comes after a sound apprenticeship; that which shall prove to be the blending of a firm conception of all useful precedent and the progressive tendencies of an able mind. For, let a man be as able and original as he may, he cannot afford to discard knowledge of what has gone before or what is now going on in his own trade and profession. If the printers of today do not wish to be esteemed too arrogant when they term this calling of theirs an art, they must be willing, and show that they are willing, to subject it to such laws as have made its sister arts so free. All those concerned in what are accepted as the fine arts, the learned sciences, and the professions surround themselves with the history, the literature, and concrete examples of the work with which they are particularly engaged. Yet it is only in very rare instances that such an atmosphere, with its material appurtenances, is to be found in a printing office. Art does not flourish in hidden places, nor under restraint, nor in ignorance of what talent and genius have accomplished and are now accomplishing throughout the world. For to follow precedent wisely does not mean to imitate slavishly one great exemplar, but to study all masters faithfully, letting their great achievements sink slowly into the mind in order that we may patiently derive from the richness of our acquired knowledge and organized system an attitude of our own. The sprightly minded young man, who with his first business breath projects the new and startling, inevitably becomes tiresome, and is driven to an early disappearance; while the slower, more solidly endowed student will at least spend as much of his time in avoiding mistakes as in evolving brilliant schemes wherewith to dazzle his contemporaries. The best kind of originality is that which comes after a sound apprenticeship; that which shall prove to

abcdefghijklmnopqrstuvwxyz  
 ABCDEFGHIJKLMNOPQRSTUVWXYZ  
 \$123456789

6 Point No. 79J, 7 Set

### MONOTYPE FACES

The best kind of originality is that which comes after a sound apprenticeship; that which shall prove to be the blending of a firm conception of all useful precedent and the progressive tendencies of an able mind. For, let a man be as able and original as he may, he cannot afford to discard knowledge of what has gone before or what is now going on in his own trade and profession. If the printers of today do not wish to be esteemed arrogant when they term this calling of theirs an art, they must be willing, and show that they are willing, to subject it to such laws as have made its sister arts so free. All those concerned in what are accepted as the fine arts, the learned sciences, and professions surround themselves with the history, the literature, and concrete examples of the work with which they are particularly engaged. Yet it is only in very rare instances that such an atmosphere, with its material appurtenances, is to be found in a printing office. Art does not flourish in hidden places, nor under restraint, nor in ignorance of what talent and genius have accomplished and are accomplishing throughout the world. For to follow all precedent wisely does not mean to imitate slavishly one great exemplar, but to study all masters faithfully, letting their great achievements sink slowly into the mind in order that we may patiently derive from the richness of our acquired knowledge and organized system an attitude of our own. The sprightly minded young man, who with his first business breath projects the new and startling, inevitably becomes tiresome, and is driven to an early disappearance; while the slower, more solidly endowed student will at least spend as much of his time in avoiding mistakes as in evolving brilliant schemes wherewith to dazzle his contemporaries. The best kind of originality is that which comes after a sound apprenticeship; that which shall prove to

abcdefghijklmnopqrstuvwxyz  
 ABCDEFGHIJKLMNOPQRSTUVWXYZ  
 \$123456789

8 Point No. 79J, 8½ Set

### MONOTYPE FACES

The best kind of originality is that which comes after a sound apprenticeship; that which shall prove to be the blending of a firm conception of all useful precedent and the progressive tendencies of an able mind. For, let a man be as able and original as he may, he cannot afford to discard knowledge of what has gone before or what is now going on in his own trade and profession. If the printers of today do not wish to be esteemed arrogant when they term this calling of theirs an art, they must be willing, and show that they are willing, to subject it to such laws as have made its sister arts so free. All those concerned in what are accepted as the fine arts, the learned sciences, and professions surround themselves with the history, the literature, and concrete examples of the work with which they are particularly engaged. Yet it is only in very rare instances that such an atmosphere, with its material appurtenances, is to be found in a printing office. Art does not flourish in hidden places, nor under restraint, nor in ignorance of what talent and genius have accomplished and are accomplishing throughout the world. For to follow precedent wisely does not mean to imitate slavishly one great exemplar, but to study all the masters faithfully, letting their great achievements sink slowly into the mind in order that we may patiently derive from the richness

abcdefghijklmnopqrstuvwxyz  
 ABCDEFGHIJKLMNOPQRSTUVWXYZ  
 \$123456789

# No. 79J. Job Arrangement C2

## Composition Matrices

9 Point No. 79J, 9 Set

### MONOTYPE FACES

The best kind of originality is that which comes after a sound apprenticeship; that which shall prove to be the blending of a firm conception of all useful precedent and of the progressive tendencies of an able mind. For, let a man be as able and original as he may, he cannot afford to discard knowledge of what has gone before or what is now going on in his own trade and profession. If the printers of today do not wish to be esteemed arrogant when they term this calling of theirs an art, they must be willing, and show that they are willing, to subject it to such laws as have made its sister arts so free. All those concerned in what are accepted as the fine arts, the learned sciences, and professions surround themselves with the history, the literature, and concrete examples of the work with which they are particularly engaged. Yet it is only in rare instances that such an atmosphere, with its material appurtenances, is to be found in a printing office. Art does not flourish in hidden places, nor

abcdefghijklmnopqrstuvwxy  
ABCDEFGHIJKLMNOPQRSTUVWXYZ  
\$1234567890

11 Point No. 79J, 11 Set

### MONOTYPE FACES

The very best kind of originality is that which comes after a sound apprenticeship; that which shall prove itself to be the blending of a firm conception of all useful precedent and the progressive tendencies of an able mind. Let any man be as able and original as he may, he cannot afford to discard knowledge of what has gone before or what is now going on in his own trade and profession. If the printers of today do not wish to be esteemed arrogant when they term this calling of theirs an art, they must be willing, and show that they are willing, to subject it to such laws as have made its sister arts so free. All those concerned in what are accepted as the fine arts, the learned sciences, and professions surround themselves with the history, literature, and concrete exam-

abcdefghijklmnopqrstuvwxy  
ABCDEFGHIJKLMNOPQRSTUVWXYZ  
\$1234567890

10 Point No. 79J, 10½ Set

### MONOTYPE FACES

The best kind of originality is that which comes after a sound apprenticeship; that which shall prove to be the blending of a firm conception of all useful precedent and the progressive tendencies of an able mind. For, let any man be as able and original as he may, he cannot afford to discard knowledge of what has gone before or what is now going on in his own trade and profession. If the printers of today do not wish to be esteemed too arrogant when they term this calling of theirs an art, they must be willing, and show that they are willing, to subject it to just such laws as have made its sister arts so free. All those concerned in what are accepted as the fine arts, the learned sciences, and professions surround themselves with the history, literature, and concrete examples

abcdefghijklmnopqrstuvwxy  
ABCDEFGHIJKLMNOPQRSTUVWXYZ  
\$1234567890

12 Point No. 79J, 12 Set

### MONOTYPE FACES

The best kind of originality is that which comes after a sound apprenticeship; that which shall prove to be the blending of a firm conception of all useful precedent and the progressive tendencies of an able mind. For, let a man be as able and original as he may, he cannot afford to discard a knowledge of what has gone before or what is now going on in his own trade and profession. If the printers of today do not wish to be esteemed arrogant when they term this calling of theirs an art, they must be willing, and show that they are willing, to subject it to such laws as have made its sister arts so free. All of those concerned in what are

abcdefghijklmnopqrstuvwxy  
ABCDEFGHIJKLMNOPQRSTUVWXYZ  
\$1234567890

14 Point No. 79

**A SAVING ON YOUR INVESTMENT**  
**No other Composing Room Machine will Produce a Greater**  
**Return for the Same Money**  
**\$1234567890**

18 Point No. 79

**REDUCES IDLE TIME**  
**Casts Type, Borders, and Spaces when not used**  
**as a Composing Machine**  
**\$1234567890**

24 Point No. 79

**NEW FOUNDRY TYPE**  
**Is Identically the Same as the Monotype**  
**Product, but Costs More**  
**\$1234567890**

30 Point No. 79

**HIGH OR LOW QUADS**  
**And Spaces Optional with the**  
**Monotype Operator**  
**\$1234567890**

36 Point No. 79

**IMPROVEMENTS**  
**Easily Applied as Required**  
**\$1234567890**

# No. 79K. Job Arrangement C2

## Composition Matrices

6 Point No. 79K, 7 Set

### MONOTYPE FACES

*The best kind of originality is that which comes after a sound apprenticeship; that which shall prove to be the blending of a firm conception of all useful precedent and the progressive tendencies of an able mind. For, let a man be as able and original as he may, he cannot afford to discard knowledge of what has gone before or what is now going on in his own trade and profession. If the printers of today do not wish to be esteemed arrogant when they term this calling of theirs an art, they must be willing, and show that they are willing, to subject it to such laws as have made its sister arts so free. All those concerned in what are accepted as the fine arts, the learned sciences, and professions surround themselves with the history, the literature, and concrete examples of the work with which they are particularly engaged. Yet it is only in very rare instances that such an atmosphere, with its material appurtenances, is to be found in a printing office. Art does not flourish in hidden places, nor under restraint, nor in ignorance of what talent and genius have accomplished and are accomplishing throughout the world. For to follow precedent wisely does not mean to imitate slavishly one great exemplar, but to study all masters faithfully, letting their great achievements sink slowly into the mind in order that we may patiently derive from the richness of our acquired knowledge and organized system an attitude of our own. The sprightly minded young man, who with his first business breath projects the new and startling, inevitably becomes tiresome, and is driven to an early disappearance; while the slower, more solidly endowed student will at least spend as much of his time in avoiding mistakes as in evolving brilliant schemes wherewith to dazzle his contemporaries. The best kind of originality is that which comes after a sound apprenticeship; that which shall prove to*

abcdefghijklmnopqrstuvwxy  
ABCDEFGHIJKLMNPOQRSTUVWXYZ  
\$1234567890

10 Point No. 79K, 10½ Set

### MONOTYPE FACES

*The best kind of originality is that which comes after a sound apprenticeship; that which shall prove to be the blending of a firm conception of all useful precedent and the progressive tendencies of an able mind. For, let any man be as able and original as he may, he cannot afford to entirely discard knowledge of what has gone before or what is now going on in his own trade and profession. If the printers of today do not wish to be esteemed too arrogant when they term this calling of theirs an art, they must be willing, and show that they are willing, to subject it to such laws as have made its sister arts so free. All those concerned in what are accepted as the fine arts, the learned sciences, and the professions surround themselves with the history, literature, and concrete examples of the work with which they are particularly engaged. Yet it is only in very rare*

abcdefghijklmnopqrstuvwxy  
ABCDEFGHIJKLMNPOQRSTUVWXYZ  
\$1234567890

8 Point No. 79K, 8½ Set

### MONOTYPE FACES

*The best kind of originality is that which comes after a sound apprenticeship; that which shall prove to be the blending of a firm conception of all useful precedent and the progressive tendencies of an able mind. For, let a man be as able and original as he may, he cannot afford to discard knowledge of what has gone before or what is now going on in his own trade or his profession. If the printers of today do not wish to be esteemed arrogant when they term this calling of theirs an art, they must be willing, and show that they are willing, to subject it to such laws as have made its sister arts so free. All those concerned in what are accepted as the fine arts, the learned sciences, and professions surround themselves with the history, the literature, and the concrete examples of the work with which they are particularly engaged. Yet it is only in very rare instances that such an atmosphere, with its material appurtenances, is to be found in a printing office. Art does not flourish in hidden places, nor under restraint, nor in ignorance of what talent and genius have accomplished and are accomplishing throughout the world. For to follow precedent wisely does not mean to imitate slavishly one great exemplar,*

abcdefghijklmnopqrstuvwxy  
ABCDEFGHIJKLMNPOQRSTUVWXYZ  
\$1234567890

12 Point No. 79K, 12 Set

### MONOTYPE FACES

*The best kind of originality is that which comes after a sound apprenticeship; that which shall prove to be the blending of a firm conception of all useful precedent and the progressive tendencies of an able mind. For, let a man be as able and original as he may, he cannot afford to discard a knowledge of what has gone before or what is now going on in his own trade and profession. If the printers of today do not wish to be esteemed arrogant when they term this calling of theirs an art, they must be willing, and show that they are willing, to subject it to such laws as have made its sister arts so free.*

abcdefghijklmnopqrstuvwxy  
ABCDEFGHIJKLMNPOQRSTUVWXYZ  
\$1234567890

14 Point No. 791

**THE SAVING ON DISTRIBUTION**  
*Made by the Monotype on Newspaper Display Advertising*  
*is One Source of Great Profit*  
**\$1234567890**

18 Point No. 791

**AND THE SATISFACTION**  
*Of Surely Having the Best Printed Paper in*  
*Your Town Is Gratifying*  
**\$1234567890**

24 Point No. 791

**THE ADVERTISING GAIN**  
*Through Splendid Display and Print*  
*Is Also Profitable*  
**\$1234567890**

30 Point No. 791

**SPACING MATERIAL**  
*And Plenty of It Is a Compos-*  
*ing Room Profit Maker*  
**\$1234567890**

36 Point No. 791

**EFFICIENCY**  
*Also Made Much Greater*  
**\$1234567890**



# No. 113J. Job Arrangement C1

## Composition Matrices

5 Point No. 113J, 5 Set

### MONOTYPE FACES

The best kind of originality is that which comes after a sound apprenticeship; that which shall prove to be the blending of a firm conception of all useful precedent and the progressive tendencies of an able mind. For, let a man be as able and original as he may, he cannot afford to discard knowledge of what has gone before or what is now going on in his own trade or his profession. If the printers of today do not wish to be esteemed arrogant when they term this calling of theirs an art, they must be willing, and show that they are willing, to subject it to such laws as have made its sister arts so free. All those concerned in what are accepted as the fine arts, the learned sciences and professions, surround themselves with the history, the literature, and concrete examples of the work with which they are particularly engaged. Yet it is only in very rare instances that such an atmosphere, with its material appurtenances, is to be found in a printing office. Art does not flourish in hidden places, nor under restraint, nor in ignorance of what talent and genius have accomplished and are accomplishing throughout the world. For to follow all precedent wisely does not mean to imitate slavishly one great exemplar, but to study all masters faithfully, letting their great achievements sink slowly into the mind in order that we may patiently derive from the richness of our acquired knowledge and organized system an attitude of our own. The sprightly minded young man, who with his first business breath projects the new and startling, inevitably becomes tiresome, and is driven to an early disappearance; while the slower, more solidly endowed student will at least spend as much of his time in avoiding mistakes as in evolving brilliant schemes wherewith to dazzle his contemporaries. The best kind of originality is that which comes after a sound apprenticeship; that which shall prove to be the blending of a firm conception of all useful precedent and the progressive tendencies of an able mind. For, let a man be as able and original as he may, he cannot afford to discard knowledge of what has gone before or what is now going on in his own trade and his profession. If the printers of today do not wish to be esteemed arrogant when they term this calling of theirs an art, they must be willing, and show that they are

abcdefghijklmnopqrstuvwxy  
 ABCDEFGHIJKLMNOPQRSTUVWXYZ  
 \$1234567890

6 Point No. 113J, 6 Set

### MONOTYPE FACES

The best kind of originality is that which comes after a sound apprenticeship; that which shall prove to be the blending of a firm conception of all useful precedent and the progressive tendencies of an able mind. For, let a man be as able and original as he may, he cannot afford to discard knowledge of what has gone before or what is now going on in his own trade and profession. If the printers of today do not wish to be esteemed too arrogant when they term this calling of theirs an art, they must be willing, and show that they are willing, to subject it to such laws as have made its sister arts so free. All those concerned in what are accepted as the fine arts, the learned sciences and the professions, surround themselves with the history, the literature, and concrete examples of the work with which they are particularly engaged. Yet it is only in very rare instances that such an atmosphere, with its material appurtenances, is to be found in a printing office. Art does not flourish in hidden places, nor under restraint, nor in ignorance of what talent and genius have accomplished and are accomplishing throughout the world. For to follow all precedent wisely does not mean to imitate slavishly one great exemplar, but to study all masters faithfully, letting their great achievements sink slowly into the mind in order that we may patiently derive from the richness of our acquired knowledge and organized system an attitude of our own. The sprightly minded young man, who with his first business breath projects the new and startling, inevitably

abcdefghijklmnopqrstuvwxy  
 ABCDEFGHIJKLMNOPQRSTUVWXYZ  
 \$1234567890

8 Point No. 113J, 8 Set

### MONOTYPE FACES

The best kind of originality is that which comes after a sound apprenticeship; that which shall prove to be the blending of a firm conception of all useful precedent and the progressive tendencies of an able mind. For, let a man be as able and original as he may, he cannot afford to discard knowledge of what has gone before or what is now going on in his own trade or his profession. If the printers of today do not wish to be esteemed arrogant when they term this calling of theirs an art, they must be willing, and show that they are willing, to subject it to such laws as have made its sister arts so free. All those concerned in what are accepted as the fine arts, the learned sciences and professions, surround themselves with the history, the literature, and concrete examples of the work

abcdefghijklmnopqrstuvwxy  
 ABCDEFGHIJKLMNOPQRSTUVWXYZ  
 \$1234567890

10 Point No. 113J, 9 Set

### MONOTYPE FACES

The best kind of originality is that which comes after a thorough apprenticeship; that which shall prove to be the blending of a firm conception of all useful precedent and the progressive tendencies of an able mind. For, let a man be as able and original as he may, he cannot afford to discard knowledge of what has gone before or what is now going on in his own trade or his profession. If the printers of today do not wish to be esteemed arrogant when they term this calling of theirs an art, they must be willing, and show that they are willing, to subject it to such laws as have made its sister arts so free. All those concerned in what are accepted as the fine arts, the learned sciences and professions, surround themselves with the history, the literature, and concrete examples of the work with which they are particularly engaged. Yet it is only in very rare instances that such an atmosphere, with its material appurtenances, is to be found in a printing office. Art does not flourish in hidden places, nor under

abcdefghijklmnopqrstuvwxy  
 ABCDEFGHIJKLMNOPQRSTUVWXYZ  
 \$1234567890

12 Point No. 113J, 11 Set

### MONOTYPE FACES

The best kind of originality is that which comes after a thorough apprenticeship; that which shall prove to be the blending of a firm conception of all useful precedent and the progressive tendencies of an able mind. For, let a man be as able and original as he may, he cannot afford to discard knowledge of what has gone before or what is now going on in his own trade and profession. If the printers of today do not wish to be esteemed too arrogant when they term this calling of theirs an art, they must be willing, and show that they are willing, to subject it to such laws as have made its sister arts so free. All those concerned in what are accepted as the fine arts, the learned sciences and professions, surround themselves with the history,

abcdefghijklmnopqrstuvwxy  
 ABCDEFGHIJKLMNOPQRSTUVWXYZ  
 \$1234567890

14 Point No. 113

**IF YOU NEED BUT ONE TYPESETTING MACHINE**  
**You Will Surely Buy a Monotype if you Thoroughly Investigate Its Wide**  
**Range of Usefulness on All Kinds of Work**  
**\$1234567890**

18 Point No. 113

**THE MONOTYPE IS NEVER IDLE**  
**For When Work Is Slack, Sorts, Borders, Ornaments and**  
**Spacing Material Can Be Cast and Put Away**  
**\$1234567890**

24 Point No. 113

**LET BUSINESS BE GOOD OR BAD**  
**In Your Composing Room, the Monotype is Still**  
**Making Money in the Pressroom**  
**\$1234567890**

30 Point No. 113

**THE SAVING ON MAKEREADY**  
**Is a Means of Profit as Well as the Saving**  
**You Make on Composition**  
**\$1234567890**

36 Point No. 113

**AND FOR LONG RUNS**  
**Electrotyping Costs are Avoided**  
**\$1234567890**

# No. 118J. Job Arrangement C1

## Composition Matrices

5½ Point No. 118J, 6½ Set

### MONOTYPE FACES

The best kind of originality is that which comes after a sound apprenticeship; that which shall prove to be the blending of a firm conception of all useful precedent and the progressive tendencies of an able mind. For, let a man be as able and original as he may, he cannot afford to discard knowledge of what has gone before or what is now going on in his own trade and profession. If the printers of today do not wish to be esteemed arrogant when they term this calling of theirs an art, they must be willing, and show that they are willing, to subject it to such laws as have made its sister arts so free. All those concerned in what are accepted as the fine arts, the learned sciences, and professions surround themselves with the history, literature, and concrete examples of the work with which they are engaged. Yet it is only in rare instances that such an atmosphere, with its material appurtenances, is to be found in a printing office. Art does not flourish in hidden places, nor under restraint, nor in ignorance of what talent and genius have accomplished and are now accomplishing throughout the world. For to follow precedent wisely does not mean to imitate slavishly one great exemplar, but to study all masters faithfully, letting their great achievements sink slowly into the mind in order that we may patiently derive from the richness of our acquired knowledge and organized system an attitude of our own. The sprightly minded young man, who with his first business breath projects the new and startling, inevitably becomes tiresome, and is driven to an early disappearance; while the slower, more solidly endowed student will at least spend as much of his time in avoiding mistakes as in evolving brilliant schemes wherewith to dazzle his contemporaries. The best kind of originality is that which comes after a sound apprenticeship; that which shall prove to be the blending of a firm conception of all useful precedent and the progressive tendencies of an able mind. For, let a man be as able and original as he may, he cannot afford to discard knowledge of what has gone before or what is now going on in his own trade and profession. If the printers of today do not wish to be esteemed arrogant when they term this calling of theirs an art, they must be willing, and show that they are willing, to subject it to such laws as have made its sister arts so free. All those concerned in what are accepted as the fine arts, the learned sciences, and professions surround themselves with the history, literature, and concrete examples of the work with which they are

abcdefghijklmnopqrstuvwxyz

ABCDEFGHIJKLMN O PQRSTU VWXYZ

1234567890

7 Point No. 118J, 8 Set

### MONOTYPE FACES

The best kind of originality is that which comes after a sound apprenticeship; that which shall prove to be the blending of a firm conception of all useful precedent and the progressive tendencies of an able mind. For, let a man be as able and original as he may, he cannot afford to discard knowledge of what has gone before or what is now going on in his own trade and profession. If the printers of today do not wish to be esteemed too arrogant when they term this calling of theirs an art, they must be willing, and show that they are willing, to subject it to such laws as have made its sister arts so free. All those concerned in what are accepted as the fine arts, the learned sciences, and the professions surround themselves with the history, the literature, and concrete examples of the work with which they are particularly engaged. Yet it is only in rare instances that such an atmosphere, with its material appurtenances, is to be found in a printing office. Art does not flourish in hidden places, nor under restraint, nor in ignorance of what talent and genius have accomplished and are now accomplishing throughout the world. For to follow precedent wisely does not mean to imitate slavishly one great exemplar, but to study all masters faithfully, letting their great achievements sink slowly into the mind in order that we may patiently derive from the richness of our acquired knowledge and organized system an attitude of our own. The sprightly minded young man, who with his first business breath projects the new and startling, inevitably becomes tiresome, and is driven to an early disappearance; while the slower, more solidly endowed student will at least spend as much of his time in avoiding mistakes as in evolving brilliant schemes wherewith to dazzle his contemporaries. The best kind of originality is that which comes after a sound appren-

abcdefghijklmnopqrstuvwxyz

ABCDEFGHIJKLMN O PQRSTU VWXYZ

1234567890

6 Point No. 118J, 7 Set

### MONOTYPE FACES

The best kind of originality is that which comes after a sound apprenticeship; that which shall prove itself to be the blending of a firm conception of useful precedent and the progressive tendencies of an able mind. For, let a man be as able and original as he may, he cannot afford to discard knowledge of what has gone before or what is now going on in his own trade and profession. If the printers of today do not wish to be esteemed arrogant when they term this calling of theirs an art, they must be willing, and show that they are willing, to subject it to such laws as have made its sister arts so free. All those concerned in what are accepted as the fine arts, the learned sciences, and professions, surround themselves with the history, literature, and concrete examples of the work with which they are particularly engaged. Yet it is only in rare instances that such an atmosphere, with its material appurtenances, is to be found in a printing office. Art does not flourish in hidden places, nor under restraint, nor in ignorance of what talent and genius have accomplished and are accomplishing throughout the world. For to follow precedent wisely does not mean to imitate slavishly one great exemplar, but to study all masters faithfully, letting their great achievements sink slowly into the mind in order that we may patiently derive from the richness of our acquired knowledge and organized system an attitude of our own. The sprightly minded young man, who with his first business breath projects the new and startling, inevitably becomes tiresome, and is driven to an early disappearance; while the slower, more solidly endowed student will at least spend as much of his time in avoiding mistakes as in evolving brilliant schemes wherewith to dazzle his contemporaries. The best kind of originality is that which comes after a sound apprenticeship; that which shall prove to be the blending of a firm conception of all useful precedent and the progressive tendencies of an able mind. For, let a man be as able and original as he may, he cannot afford to discard knowledge of what has gone before or what is now going on in his own trade and profession.

abcdefghijklmnopqrstuvwxyz

ABCDEFGHIJKLMN O PQRSTU VWXYZ

1234567890

8 Point No. 118J, 8½ Set

### MONOTYPE FACES

The best kind of originality is that which comes after a sound apprenticeship; that which shall prove to be the blending of a firm conception of all useful precedent and the progressive tendencies of an able mind. For, let a man be as able and original as he may, he cannot afford to discard knowledge of what has gone before or what is now going on in his own trade and profession. If the printers of today do not wish to be esteemed arrogant when they term this calling of theirs an art, they must be willing, and show that they are willing, to subject it to such laws as have made its sister arts so free. All those concerned in what are accepted as the fine arts, the learned sciences, and professions, surround themselves with the history, the literature, and concrete examples of the work with which they are particularly engaged. Yet it is only in rare instances that such an atmosphere, with its material appurtenances, is to be found in a printing office. Art does not flourish in hidden places, nor under restraint, nor in ignorance of what talent and genius have accomplished and are now accomplishing throughout the world. For to follow precedent wisely does not mean to imitate slavishly one great exemplar, but to study all masters faithfully, letting their great achievements sink slowly into the mind in order that we may patiently derive from the richness of our acquired knowledge and organized system an attitude of our own. The sprightly minded young man, who with his first business breath projects the new and

abcdefghijklmnopqrstuvwxyz

ABCDEFGHIJKLMN O PQRSTU VWXYZ

1234567890

# No. 118J. Job Arrangement C1

## Composition Matrices

9 Point No. 118J, 9 Set

### MONOTYPE FACES

The best kind of originality is that which comes after a sound apprenticeship; that which shall prove to be the blending of a firm conception of all useful precedent and the progressive tendencies of an able mind. For, let a man be as able and original as he may, he cannot afford to discard knowledge of what has gone before or what is now going on in his own trade and profession. If the printers of today do not wish to be esteemed arrogant when they term this calling of theirs an art, they must be willing, and show that they are willing, to subject it to such laws as have made its sister arts so free. All those concerned in what are accepted as the fine arts, the learned sciences and professions, surround themselves with the history, the literature, and concrete examples of the work with which they may be particularly engaged. Yet it is only in rare instances that such an atmosphere, with all its material appurtenances, is to be found in the printing office. Art does not flourish in hidden places, nor under restraint, nor in ignorance of what talent and genius have accomplished and are now accomplishing throughout the

abcdefghijklmnopqrstuvwxy

ABCDEFGHIJKLMNQPQRSTUVWXYZ

\$1234567890

11 Point No. 118J, 11 Set

### MONOTYPE FACES

The best kind of originality is that which comes after a sound apprenticeship; that which shall prove to be the blending of a firm conception of all useful precedent and the progressive tendencies of an able mind. For, let a man be as able and original as he may, he cannot afford to discard knowledge of what has gone before or what is now going on in his own trade and profession. If the printers of today do not wish to be esteemed arrogant when they term this calling of theirs an art, they must be willing, and show that they are willing, to subject it to such laws as have made its sister arts so free. All those concerned in what are accepted as the fine arts, the learned sciences and professions, surround themselves with the history, literature, and concrete examples of the work with which they are particularly engaged. Yet it is only in rare instances that such an

abcdefghijklmnopqrstuvwxy

ABCDEFGHIJKLMNQPQRSTUVWXYZ

\$1234567890

10 Point No. 118J, 10 Set

### MONOTYPE FACES

The best kind of originality is that which comes after a sound apprenticeship; that which shall prove to be the blending of a firm conception of all useful precedent and the progressive tendencies of an able mind. For, let a man be as able and original as he may, he cannot afford to discard knowledge of what has gone before or what is now going on in his own trade and profession. If the printers of today do not wish to be esteemed arrogant when they term this calling of theirs an art, they must be willing, and show that they are willing, to subject it to such laws as have made its sister arts so free. All those concerned in what are accepted as the fine arts, the learned sciences and professions, surround themselves with the history, literature, and concrete examples of the work with which they are particularly engaged. Yet it is only in rare instances that such an atmosphere, with its

abcdefghijklmnopqrstuvwxy

ABCDEFGHIJKLMNQPQRSTUVWXYZ

\$1234567890

12 Point No. 118J, 12 Set

### MONOTYPE FACES

The best kind of originality is that which comes after a sound apprenticeship; that which shall prove to be the blending of a firm conception of all useful precedent and the progressive tendencies of an able mind. For, let any man be as able and original as he may, he cannot afford to discard knowledge of what has gone before or what is now going on in his own trade and profession. If the printers of today do not wish to be esteemed arrogant when they term this calling of theirs an art, they must be willing, and show that they are willing, to subject it to such laws as have made its sister arts so free. All those concerned in what are accepted as the fine arts, the learned sciences and the professions, surround themselves with the

abcdefghijklmnopqrstuvwxy

ABCDEFGHIJKLMNQPQRSTUVWXYZ

\$1234567890

14 Point No. 118

**THE MECHANICAL PERFECTION**  
Of the Cellular Matrix means Low Production costs. It Eliminates  
Stoppages and Operating Troubles  
**\$1234567890**

18 Point No. 118

**ALL MONOTYPE IMPROVEMENTS**  
Applied to any Machine at Small Cost, Keeping your  
Equipment Up to Date  
**\$1234567890**

24 Point No. 118

**MONOTYPE FLEXIBILITY**  
Stands for a Machine Equal to the Most  
Exacting Typographical Needs  
**\$1234567890**

30 Point No. 118

**THE NEW DOUBLE MATRIX**  
For Producing figures as large as  
36 Point in Justified Lines  
**\$1234567890**

36 Point No. 118

**NO HAND WORK**  
In Composing 36 Pt. Figures  
**\$1234567890**

Composition Matrices

6 Point No. 118K, 7 Set

MONOTYPE FACES

The best kind of originality is that which comes after a sound apprenticeship; that which shall prove to be the blending of a firm conception of all useful precedent and the progressive tendencies of an able mind. For, let a man be as able and original as he may, he cannot afford to discard knowledge of what has gone before or what is now going on in his own trade and profession. If the printers of today do not wish to be esteemed arrogant when they term this calling of theirs an art, they must be willing, and show that they are willing, to subject it to such laws as have made its sister arts so free. All those concerned in what are accepted as the fine arts, the learned sciences, and professions surround themselves with the history, literature, and the concrete examples of the work with which they are particularly engaged. Yet it is only in very rare instances that this atmosphere, with its material appurtenances, is to be found in a printing office. Art does not flourish in hidden places, nor under restraint, nor in ignorance of what talent and genius have accomplished and are accomplishing throughout the world. For to follow precedent wisely does not mean to imitate too slavishly one great exemplar, but to study all masters faithfully, letting their great achievements sink slowly into the mind in order that we may patiently derive from the richness of our acquired knowledge and organized system an attitude of our own. The sprightly minded young man, who with his first business breath projects the new and startling, inevitably becomes tiresome, and is driven to an early disappearance; while the slower, more solidly endowed student will at least spend a much of his time in avoiding mistakes as in evolving brilliant schemes wherewith to dazzle his contemporaries. The best kind of originality is that which comes after a sound apprenticeship; that which shall prove to

abcdefghijklmnopqrstuvwxyz

ABCDEFGHIJKLMN OPQRSTUVWXYZ

\$1234567890

10 Point No. 118K, 10 Set

MONOTYPE FACES

The best kind of originality is that which comes after a sound apprenticeship; that which shall prove to be the blending of a firm conception of all useful precedent and the progressive tendencies of an able mind. For, let a man be as able and original as he may, he cannot afford to discard knowledge of what has gone before or what is now going on in his own trade and profession. If the printers of today do not wish to be esteemed too arrogant when they term this calling of theirs an art, they must be willing, and show that they are willing, to subject it to such laws as have made its sister arts so free. All those concerned in what are accepted as the fine arts, the learned sciences, and professions surround themselves with the history, literature, and concrete examples of the work with which they are particularly engaged. Yet it is only in rare instances that such an atmosphere, with its material appurtenances, is to be found in the printing office.

abcdefghijklmnopqrstuvwxyz

ABCDEFGHIJKLMN OPQRSTUVWXYZ

\$1234567890

8 Point No. 118K, 8 Set

MONOTYPE FACES

The best kind of originality is that which comes after a sound apprenticeship; that which shall prove to be the blending of a firm conception of all useful precedent and the progressive tendencies of an able mind. For, let a man be as able and original as he may, he cannot afford to discard knowledge of what has gone before or what is now going on in his own trade or his profession. If the printers of today do not wish to be esteemed arrogant when they term this calling of theirs an art, they must be willing, and show that they are willing, to subject it to such laws as have made its sister arts so free. All those concerned in what are accepted as the fine arts, the learned sciences, and professions surround themselves with the history, the literature, and the concrete examples of the work with which they are particularly engaged. Yet it is only in very rare instances that such an atmosphere, with its material appurtenances, is to be found in a printing office. Art does not flourish in hidden places, nor under restraint, nor in ignorance of what talent and genius have accomplished and are accomplishing throughout the world. For to follow precedent wisely does not mean to imitate slavishly one great exemplar,

abcdefghijklmnopqrstuvwxyz

ABCDEFGHIJKLMN OPQRSTUVWXYZ

\$1234567890

12 Point No. 118K, 12 Set

MONOTYPE FACES

The best kind of originality is that which comes after a sound apprenticeship; that which shall prove to be the blending of a firm conception of all useful precedent and the progressive tendencies of an able mind. For, let a man be as able and original as he may, he cannot well afford to discard knowledge of what has gone before or what is now going on in his own trade and profession. If the printers of today do not wish to be esteemed arrogant when they term this calling of theirs an art, they must be willing, and show that they are willing; to subject it to such laws as have made its sister arts so free. All those who are concerned in what

abcdefghijklmnopqrstuvwxyz

ABCDEFGHIJKLMN OPQRSTUVWXYZ

\$1234567890

14 Point No. 1181

**ONE MATRIX FOR EACH LETTER**

*Two Letters are Never Carried on the Same Matrix in the Flexible Monotype System*

**\$1234567890**

18 Point No. 1181

**A MATRIX FOR EACH CHARACTER**

*Each Matrix a Unit, these Units Combined in the Matrix Case as Required.*

**\$1234567890**

24 Point No. 1181

**HAND WORK & CORRECTING**

*Are done by a Compositor on the Monotype and not by a Machinist*

**\$1234567890**

30 Point No. 1181

**THE MONOTYPE IS NOT**

*A Stick to set Matrices by Hand from a "pi box"*

**\$1234567890**

36 Point No. 1181

**ALL FACES 5 TO 12 PT.**

*Line if Cast on Same Body*

**\$1234567890**

# No. 38E. Book Arrangement C

## Composition Matrices

6 Point No. 38E, 7 Set

### MONOTYPE FACES

The best kind of originality is that which comes after a sound apprenticeship; that which shall prove itself to be the blending of a firm conception of useful precedent and the progressive tendencies of an able mind. For, let a man be as able and original as he may, he cannot afford to discard knowledge of what has gone before or what is now going on in his own trade and profession. If the printers of today do not wish to be esteemed arrogant when they term this calling of theirs an art, they must be willing, and show that they are willing, to subject it to such laws as have made its sister arts so free. All those concerned in what are accepted as the fine arts, the learned sciences, and professions surround themselves with the history, literature, and concrete examples of work with which they are particularly engaged. Yet it is only in very rare instances that such an atmosphere, with its material appurtenances, is to be found in the printing office. Art does not flourish in hidden places, nor under restraint, nor in ignorance of what talent and genius have accomplished and are accomplishing throughout the world. For to follow precedent wisely does not mean to imitate slavishly one great exemplar, but to study all masters faithfully, letting their great achievements sink slowly into the mind in order that we may patiently derive from the richness of our acquired knowledge and organized system an attitude of our own. The sprightly minded young man, who with his first business breath projects the new and startling, inevitably becomes tiresome, and is driven to an early disappearance, while the slower and more solidly endowed student will at least spend as much of his time in avoiding mistakes as in evolving brilliant schemes wherewith to dazzle his contemporaries. The best kind of originality is that which comes after a sound apprenticeship; that which shall prove itself to be the blending of a firm conception of all useful precedent and the progressive tendencies of an able mind. For, let a man be as able and original as he

12345      abcdefghijklmnopqrstuvwxyz      67890\$  
 ABCDEFGHIJKLMNOPQRSTUVWXYZ  
 ABCDEFGHIJKLMNOPQRSTUVWXYZ  
 12345      abcdefghijklmnopqrstuvwxyz      67890\$  
 ABCDEFGHIJKLMNOPQRSTUVWXYZ

8 Point No. 38E, 8½ Set

### MONOTYPE FACES

The best kind of originality is that which comes after a sound apprenticeship; that which shall prove to be the blending of a firm conception of all useful precedent and the progressive tendencies of an able mind. For, let a man be as able and original as he may, he cannot afford to discard knowledge of what has gone before or what is now going on in his own trade and profession. If the printers of today do not wish to be esteemed arrogant when they term this calling of theirs an art, they must be willing, and show that they are willing, to subject it to such laws as have made its sister arts so free. All those concerned in what are accepted as the fine arts, the learned sciences, and the professions surround themselves with the history, the literature, and concrete examples of the work with which they are particularly engaged. Yet it is only in very rare instances that such an atmosphere, with its material appurtenances, is to be found in a printing office. Art does not flourish in hidden places, nor under restraint, nor in ignorance of what talent and genius have accomplished and are now accomplishing throughout the world. For to follow precedent wisely does not mean to imitate slavishly one great exemplar, but to study all masters faithfully, letting their great achievements sink slowly into the mind in order that we may patiently derive from the richness

12345      abcdefghijklmnopqrstuvwxyz      67890\$  
 ABCDEFGHIJKLMNOPQRSTUVWXYZ  
 ABCDEFGHIJKLMNOPQRSTUVWXYZ  
 12345      abcdefghijklmnopqrstuvwxyz      67890\$  
 ABCDEFGHIJKLMNOPQRSTUVWXYZ

7 Point No. 38E, 8 Set

### MONOTYPE FACES

The best kind of originality is that which comes after a sound apprenticeship; that which shall prove to be the blending of a firm conception of all useful precedent and the progressive tendencies of an able mind. For, let a man be as able and original as he may, he cannot afford to discard knowledge of what has gone before or what is now going on in his own trade and profession. If the printers of today do not wish to be esteemed arrogant when they term this calling of theirs an art, they must be willing, and show that they are willing, to subject it to such laws as have made its sister arts so free. All those concerned in what are accepted as the fine arts, the learned sciences, and the professions surround themselves with the history, literature, and the concrete examples of the work with which they are particularly engaged. Yet it is only in rare instances that such an atmosphere, with its material appurtenances, is to be found in a printing office. Art does not flourish in hidden places, nor under restraint, nor in ignorance of what talent and genius have accomplished and are accomplishing throughout the world. For to follow precedent wisely does not mean to imitate slavishly one great exemplar, but to study all masters faithfully, letting their great achievements sink slowly into the mind in order that we may patiently derive from the richness of our acquired knowledge and organized system an attitude of our own. The sprightly minded young man, who with his first business breath projects the new and startling, inevitably becomes tiresome, and is driven to an early

12345      abcdefghijklmnopqrstuvwxyz      67890\$  
 ABCDEFGHIJKLMNOPQRSTUVWXYZ  
 ABCDEFGHIJKLMNOPQRSTUVWXYZ  
 12345      abcdefghijklmnopqrstuvwxyz      67890\$  
 ABCDEFGHIJKLMNOPQRSTUVWXYZ

9 Point No. 38E, 9 Set

### MONOTYPE FACES

The best kind of originality is that which comes after a sound apprenticeship; that which shall prove to be the blending of a firm conception of all useful precedent and the progressive tendencies of an able mind. For, let a man be as able and original as he may, he cannot afford to discard knowledge of what has gone before or what is now going on in his own trade and profession. If the printers of today do not wish to be esteemed arrogant when they term this calling of theirs an art, they must be willing, and show that they are willing, to subject it to such laws as have made its sister arts so free. All those concerned in what are accepted as the fine arts, the learned sciences, and the professions surround themselves with the history, literature, and concrete examples of the work with which they are particularly engaged. Yet it is only in rare instances that such an atmosphere, with its material appurtenances is to be found in a printing office. Art does not flourish in hidden places, nor under restraint, nor in ignorance of what talent and genius have accomplished and are now accomplishing throughout the world. For to

12345      abcdefghijklmnopqrstuvwxyz      67890\$  
 ABCDEFGHIJKLMNOPQRSTUVWXYZ  
 ABCDEFGHIJKLMNOPQRSTUVWXYZ  
 12345      abcdefghijklmnopqrstuvwxyz      67890\$  
 ABCDEFGHIJKLMNOPQRSTUVWXYZ



# No. 98E. Book Arrangement C

## Composition Matrices

10 Point No. 38E, 10 Set

### MONOTYPE FACES

The best kind of originality is that which comes after a sound apprenticeship; that which shall prove to be the blending of a firm conception of all useful precedent and the progressive tendencies of an able mind. For, let a man be as able and original as he may, he cannot afford to discard knowledge of what has gone before or what is now going on in his own trade and profession. If the printers of today do not wish to be esteemed arrogant when they term this calling of theirs an art, they must be willing, and show that they are willing, to subject it to such laws as have made its sister arts so free. All those who are concerned in what are accepted as the fine arts, the learned sciences, and the professions surround themselves with the history, the literature, and concrete examples of the work with which they are particularly engaged. *Yet it is only in rare instances that such an atmosphere, with its material appurten-*

12345 abcdefghijklmnopqrstuvwxyz 67890\$

ABCDEFGHIJKLMNOPQRSTUVWXYZ

ABCDEFGHIJKLMNOPQRSTUVWXYZ

12345 abcdefghijklmnopqrstuvwxyz 67890\$

ABCDEFGHIJKLMNOPQRSTUVWXYZ

11 Point No. 38E, 11 Set

### MONOTYPE FACES

The very best kind of originality is that which comes after a thorough apprenticeship; that which shall prove to be the blending of a firm conception of all useful precedent and the progressive tendencies of an able mind. For, let a man be as able and original as he may, he cannot afford to discard knowledge of what has gone before or what is now going on in his own trade and profession. If the printers of today do not wish to be esteemed arrogant when they term this calling of theirs an art, they must be willing, and show that they are willing, to subject it to such laws as have made its sister arts so free. All those concerned in what are accepted as the fine arts, the learned sciences, and the professions surround themselves with the history, literature.

12345 abcdefghijklmnopqrstuvwxyz 67890\$

ABCDEFGHIJKLMNOPQRSTUVWXYZ

ABCDEFGHIJKLMNOPQRSTUVWXYZ

12345 abcdefghijklmnopqrstuvwxyz 67890\$

ABCDEFGHIJKLMNOPQRSTUVWXYZ

12 Point No. 38E, 12 Set

### MONOTYPE FACES

The best kind of originality is that which comes after a sound apprenticeship; that which shall prove to be the blending of a firm conception of all useful precedent and the progressive tendencies of an able mind. For, let any man be as able and original as he may, he cannot afford to discard knowledge of what has gone before or what is now going on in his own trade and profession. If the printers of today do not wish to be esteemed arrogant when they term this calling of theirs an art,

12345 abcdefghijklmnopqrstuvwxyz 67890\$

ABCDEFGHIJKLMNOPQRSTUVWXYZ

ABCDEFGHIJKLMNOPQRSTUVWXYZ

12345 abcdefghijklmnopqrstuvwxyz 67890\$

ABCDEFGHIJKLMNOPQRSTUVWXYZ

### MONOTYPE FACES

The best kind of originality is that which comes after a sound apprenticeship; that which shall prove to be the blending of a firm conception of all useful precedent and the progressive tendencies of an able mind. For, let any man be as able and original as he may, he cannot afford to discard knowledge of what has gone before or what is now going on in his own trade and profession. If the printers of today do not wish to be esteemed arrogant when they term this calling of theirs an art, they must be willing, and show that they are willing, to subject it to such laws

14 Point No. 38

THERE IS A DIFFERENCE

Between what any Monotype will do and what other Machines can do.  
No other Machine will do half what it does

\$1234567890

18 Point No. 38

OUR REPEAT ORDER RECORD

Thirty-eight out of Every Hundred Monotypes sold to  
Satisfied Customers on Repeat Orders

\$1234567890

24 Point No. 38

TYPE CASTER TIPS

Don't Consider a Machine without a Visible  
Supply of its own Matrices

\$1234567890

30 Point No. 38

CAST TYPE QUICKLY

It Pays Better to make New Type  
than to Distribute

\$1234567890

36 Point No. 38

BUY THE MACHINE

With a Repeat Order Record

\$1234567890

14 Point No. 381

**SEVEN HUNDRED AND FIFTY FONTS**

*For Use on the Monotype; a Larger Matrix Equipment than that of all other Type Casters and Composing Machines Combined*

\$1234567890

18 Point No. 381

**QUALITY AND PRODUCTION**

*Are Monotype Type Casting Features Equal to its Adequate and Varied Matrix Equipment*

\$1234567890

24 Point No. 381

**PERFECTLY JUSTIFIED LINES**

*Composed on Ordinary Galleys is the Only Way and the Monotype Way*

\$1234567890

30 Point No. 381

**MONOTYPE LINE**

*Means a Uniform Line for all Sizes and Faces on any Body*

\$1234567890

36 Point No. 381

**THE DD KEYBOARD**

*Two Products for the One Cost*

\$1234567890

# No. 61E. Book Arrangement C

## Composition Matrices

### 6 Point No. 61E, 7 Set

#### MONOTYPE FACES

The best kind of originality is that which comes after a sound apprenticeship; that which shall prove itself to be the blending of a firm conception of useful precedent and the progressive tendencies of an able mind. For, let a man be as able and original as he may, he cannot afford to discard knowledge of what has gone before or what is now going on in his own trade and profession. If the printers of today do not wish to be esteemed arrogant when they term this calling of theirs an art, they must be willing, and show that they are willing, to subject it to such laws as have made its sister arts so free. All those concerned in what are accepted as the fine arts, the learned sciences, and professions surround themselves with the history, literature, and concrete examples of the work with which they are particularly engaged. Yet it is only in rare instances that such an atmosphere, with its material appurtenances, is to be found in a printing office. Art does not flourish in hidden places, nor under restraint, nor in ignorance of what talent and genius have accomplished and are accomplishing throughout the world. For to follow precedent wisely does not mean to imitate slavishly one great exemplar, but to study all masters faithfully, letting their great achievements sink slowly into the mind in order that we may patiently derive from the richness of our acquired knowledge and organized system an attitude of our own. The sprightly minded young man, who with his first business breath projects the new and startling, inevitably becomes tiresome, and is driven to an early disappearance; while the slower, more solidly endowed student will at least spend as much of his time in avoiding mistakes as in evolving brilliant schemes wherewith to dazzle his contemporaries. The best kind of originality is that which comes after a sound apprenticeship; that which shall prove to be the blending of a firm conception of all useful precedent and the progressive tendencies of an able mind. For, let a man be as able and original as he may, he cannot afford to discard knowledge of what has gone before or what is now going on in his own trade and profession. If the

12345      abcdefghijklmnopqrstuvwxyz      67890\$  
 ABCDEFGHIJKLMNOPQRSTUVWXYZ  
 ABCDEFGHIJKLMNOPQRSTUVWXYZ  
 12345      abcdefghijklmnopqrstuvwxyz      67890\$  
 ABCDEFGHIJKLMNOPQRSTUVWXYZ

### 8 Point No. 61E, 8½ Set

#### MONOTYPE FACES

The best kind of originality is that which comes after a sound apprenticeship; that which shall prove to be the blending of a firm conception of all useful precedent and the progressive tendencies of an able mind. For, let a man be as able and original as he may, he cannot afford to discard knowledge of what has gone before or what is now going on in his own trade and profession. If the printers of today do not wish to be esteemed arrogant when they term this calling of theirs an art, they must be willing, and show that they are willing, to subject it to such laws as have made its sister arts so free. All those concerned in what are accepted as the fine arts, the learned sciences, and professions surround themselves with the history, the literature, and concrete examples of the work with which they may be particularly engaged. Yet it is only in rare instances that such an atmosphere, with its material appurtenances, is to be found in a printing office. Art does not flourish in hidden places, nor under restraint, nor in ignorance of what talent and genius have accomplished and are now accomplishing throughout the world. For to follow precedent wisely does not mean to imitate slavishly one great exemplar, but to study all the masters faithfully, letting their great achievements sink slowly into the mind in order that we may patiently derive from the

12345      abcdefghijklmnopqrstuvwxyz      67890\$  
 ABCDEFGHIJKLMNOPQRSTUVWXYZ  
 ABCDEFGHIJKLMNOPQRSTUVWXYZ  
 12345      abcdefghijklmnopqrstuvwxyz      67890\$  
 ABCDEFGHIJKLMNOPQRSTUVWXYZ

### 7 Point No. 61E, 8 Set

#### MONOTYPE FACES

The best kind of originality is that which comes after a sound apprenticeship; that which shall prove to be the blending of a firm conception of all useful precedent and the progressive tendencies of an able mind. For, let a man be as able and original as he may, he cannot afford to discard knowledge of what has gone before or what is now going on in his own trade and profession. If the printers of today do not wish to be esteemed arrogant when they term this calling of theirs an art, they must be willing, and show that they are willing, to subject it to such laws as have made its sister arts so free. All those concerned in what are accepted as the fine arts, the learned sciences, and professions, surround themselves with the history, the literature, and concrete examples of the work with which they may be particularly engaged. Yet it is only in rare instances that such an atmosphere, with its material appurtenances, is to be found in a printing office. Art does not flourish in hidden places, nor under restraint, nor in ignorance of what talent and genius have accomplished and are now accomplishing throughout the world. For to follow precedent wisely does not mean to imitate slavishly one great exemplar, but to study all the masters faithfully, letting their great achievements sink slowly into the mind in order that we may patiently derive from the richness of our acquired knowledge and organized system an attitude of our own. The sprightly minded young man, who with his first business breath projects the new and startling, inevitably becomes tiresome, and is driven to an early disappearance; while the slower, more solidly

12345      abcdefghijklmnopqrstuvwxyz      67890\$  
 ABCDEFGHIJKLMNOPQRSTUVWXYZ  
 ABCDEFGHIJKLMNOPQRSTUVWXYZ  
 12345      abcdefghijklmnopqrstuvwxyz      67890\$  
 ABCDEFGHIJKLMNOPQRSTUVWXYZ

### 9 Point No. 61E, 9 Set

#### MONOTYPE FACES

The best kind of originality is that which comes after a sound apprenticeship; that which shall prove to be the blending of a firm conception of all useful precedent and the progressive tendencies of an able mind. For, let a man be as able and original as he may, he cannot afford to discard knowledge of what has gone before or what is now going on in his own trade and profession. If the printers of today do not wish to be esteemed arrogant when they term this calling of theirs an art, they must be willing, and show that they are willing, to subject it to such laws as have made its sister arts so free. All those concerned in what are accepted as the fine arts, the learned sciences, and professions surround themselves with the history, the literature, and concrete examples of the work with which they may be particularly engaged. Yet it is only in rare instances that such an atmosphere, with its material appurtenances, is to be found in a printing office. Art does not flourish in hidden places, nor under restraint, nor in ignorance of what talent and genius have accomplished and are now accomplishing throughout the world. For to follow precedent wisely does not mean to imitate slavishly one great

12345      abcdefghijklmnopqrstuvwxyz      67890\$  
 ABCDEFGHIJKLMNOPQRSTUVWXYZ  
 ABCDEFGHIJKLMNOPQRSTUVWXYZ  
 12345      abcdefghijklmnopqrstuvwxyz      67890\$  
 ABCDEFGHIJKLMNOPQRSTUVWXYZ

# No. 61E. Book Arrangement C

## Composition Matrices

10 Point No. 61E, 10¼ Set  
**MONOTYPE FACES**

The best kind of originality is that which comes after a sound apprenticeship; that which shall prove to be the blending of a firm conception of all useful precedent and the progressive tendencies of an able mind. For, let a man be as able and original as he may, he cannot afford to discard knowledge of what has gone before or what is now going on in his own trade and profession. If the printers of today do not wish to be esteemed arrogant when they term this calling of theirs an art, they must be willing, and show that they are willing, to subject it to such laws as have made its sister arts so free. All those concerned in what are accepted as the fine arts, the learned sciences, and professions surround themselves with the history, the literature, and concrete examples of the work with which they may be particularly engaged. Yet it is only in rare instances that such an atmosphere, with its material

12345 abcdefghijklmnopqrstuvwxyz 67890\$  
 ABCDEFGHIJKLMNOPQRSTUVWXYZ  
 ABCDEFGHIJKLMNOPQRSTUVWXYZ  
 12345 abcdefghijklmnopqrstuvwxyz 67890\$  
 ABCDEFGHIJKLMNOPQRSTUVWXYZ

12 Point No. 61E, 12 Set  
**MONOTYPE FACES**

The best kind of originality is that which comes after a sound apprenticeship; that which shall prove to be the blending of a firm conception of all useful precedent and the progressive tendencies of an able mind. For, let any man be as able and original as he may, he cannot afford to discard knowledge of what has gone before or what is now going on in his own trade and profession. If the printers of today do not wish to be esteemed arrogant when they term this calling of theirs an art, they must be willing, and show that they are willing, to subject it to such laws as have made its sister arts so free. All those concerned in what are accepted as the

12345 abcdefghijklmnopqrstuvwxyz 67890\$  
 ABCDEFGHIJKLMNOPQRSTUVWXYZ  
 ABCDEFGHIJKLMNOPQRSTUVWXYZ  
 12345 abcdefghijklmnopqrstuvwxyz 67890\$  
 ABCDEFGHIJKLMNOPQRSTUVWXYZ

10 Point No. 61E, 10¼ Set  
**MONOTYPE FACES**

The best kind of originality is that which comes after a sound apprenticeship; that which shall prove to be the blending of a firm conception of all useful precedent and the progressive tendencies of an able mind. For, let a man be as able and original as he may, he cannot afford to discard knowledge of what has gone before or what is now going on in his own trade and profession. If the printers of today do not wish to be esteemed arrogant when they term this calling of theirs an art, they must be willing, and show that they are willing, to subject it to such laws as have made its sister arts so free. All those concerned in what are accepted as the fine arts, the learned sciences, and professions surround themselves with the history, the literature, and concrete

12 Point No. 61E, 12 Set  
**MONOTYPE FACES**

The best kind of originality is that which comes after a sound apprenticeship; that which shall prove to be the blending of a firm conception of all useful precedent and the progressive tendencies of an able mind. For, let any man be as able and original as he may, he cannot afford to discard knowledge of what has gone before or what is now going on in his own trade and profession. If the printers of today do not wish to be esteemed arrogant when they term this calling of theirs an art, they must be willing, and show that they are willing, to subject it to such laws

# No. 71E. Book Arrangement C

## Composition Matrices

6 Point No. 71E, 7 Set

### MONOTYPE FACES

The best kind of originality is that which comes after a sound apprenticeship; that which shall prove itself to be the blending of a firm conception of useful precedent and the progressive tendencies of an able mind. For, let a man be as able and original as he may, he cannot afford to discard knowledge of what has gone before or what is now going on in his own trade and profession. If the printers of today do not wish to be esteemed arrogant when they term this calling of theirs an art, they must be willing, and show that they are willing, to subject it to such laws as have made its sister arts so free. All those concerned in what are accepted as the fine arts, the learned sciences, and professions surround themselves with the history, literature, and concrete examples of work with which they are particularly engaged. Yet it is only in very rare instances that such an atmosphere, with its material appurtenances, is to be found in the printing office. Art does not flourish in hidden places, nor under restraint, nor in ignorance of what talent and genius have accomplished and are accomplishing throughout the world. For to follow precedent wisely does not mean to imitate slavishly one great exemplar, but to study all masters faithfully, letting their great achievements sink slowly into the mind in order that we may patiently derive from the richness of our acquired knowledge and organized system an attitude of our own. The sprightly minded young man, who with his first business breath projects the new and startling, inevitably becomes tiresome, and is driven to an early disappearance; while the slower and more solidly endowed student will at least spend as much of his time in avoiding mistakes as in evolving brilliant schemes wherewith to dazzle his contemporaries. The best kind of originality is that which comes after a sound apprenticeship; that which shall prove itself to be the blending of a firm conception of all useful precedent and the progressive tendencies of an able mind. For, let a man be as able and original as he

12345 abcdefghijklmnopqrstuvwxyz 67890\$  
 ABCDEFGHIJKLMNOPQRSTUVWXYZ  
 ABCDEFGHIJKLMNOPQRSTUVWXYZ  
 12345 abcdefghijklmnopqrstuvwxyz 67890\$  
 ABCDEFGHIJKLMNOPQRSTUVWXYZ

8 Point No. 71E, 8½ Set

### MONOTYPE FACES

The best kind of originality is that which comes after a sound apprenticeship; that which shall prove to be the blending of a firm conception of all useful precedent and the progressive tendencies of an able mind. For, let a man be as able and original as he may, he cannot afford to discard knowledge of what has gone before or what is now going on in his own trade and profession. If the printers of today do not wish to be esteemed arrogant when they term this calling of theirs an art, they must be willing, and show that they are willing, to subject it to such laws as have made its sister arts so free. All those concerned in what are accepted as the fine arts, the learned sciences, and the professions surround themselves with the history, the literature, and concrete examples of the work with which they are particularly engaged. Yet it is only in very rare instances that such an atmosphere, with its material appurtenances, is to be found in a printing office. Art does not flourish in hidden places, nor under restraint, nor in ignorance of what talent and genius have accomplished and are now accomplishing throughout the world. For to follow all precedent wisely does not mean to imitate slavishly one great exemplar, but to study all masters faithfully

12345 abcdefghijklmnopqrstuvwxyz 67890\$  
 ABCDEFGHIJKLMNOPQRSTUVWXYZ  
 ABCDEFGHIJKLMNOPQRSTUVWXYZ  
 12345 abcdefghijklmnopqrstuvwxyz 67890\$  
 ABCDEFGHIJKLMNOPQRSTUVWXYZ

10 Point No. 71E, 10 Set

### MONOTYPE FACES

The best kind of originality is that which comes after a sound apprenticeship; that which shall prove to be the blending of a firm conception of all useful precedent and the progressive tendencies of an able mind. For, let a man be as able and original as he may, he cannot afford to discard knowledge of what has gone before or what is now going on in his own trade and profession. If the printers of today do not wish to be esteemed arrogant when they term this calling of theirs an art, they must be willing, and show that they are willing, to subject it to such laws as have made its sister arts so free. All those concerned in what are accepted as the fine arts, the learned sciences, and the professions surround themselves with the history, the literature, and concrete examples of the work with which they are

12345 abcdefghijklmnopqrstuvwxyz 67890\$  
 ABCDEFGHIJKLMNOPQRSTUVWXYZ  
 ABCDEFGHIJKLMNOPQRSTUVWXYZ  
 12345 abcdefghijklmnopqrstuvwxyz 67890\$  
 ABCDEFGHIJKLMNOPQRSTUVWXYZ

### MONOTYPE FACES

The best kind of originality is that which comes after a sound apprenticeship; that which shall prove to be the blending of a firm conception of all useful precedent and the progressive tendencies of an able mind. For, let a man be as able and original as he may, he cannot afford to discard knowledge of what has gone before or what is now going on in his own trade and profession. If the printers of today do not wish to be esteemed arrogant when they term this calling of theirs an art, they must be willing, and show that they are willing, to subject it to such laws as have made its sister arts so free. All those concerned in what are accepted as the fine arts, the learned sciences, and the professions surround themselves with the history, literature, and concrete examples of the work with which they are particularly engaged. Yet it is only in rare instances that such an atmosphere, with its material appurtenances, is to be found in a printing office.

# No. 71E. Book Arrangement C

## Composition Matrices

11 Point No. 71E, 11 Set

### MONOTYPE FACES

The very best kind of originality is that which comes after a thorough apprenticeship; that which shall prove to be the blending of a firm conception of all useful precedent and the progressive tendencies of an able mind. For, let a man be as able and original as he may, he cannot afford to discard knowledge of what has gone before or what is now going on in his own trade and profession. If the printers of today do not wish to be esteemed arrogant when they term this calling of theirs an art, they must be willing, and show that they are willing, to subject it to such laws as have made its sister arts so free. All those *concerned in what are accepted as the fine arts, the learned sciences, and professions surround*

12345 abcdefghijklmnopqrstuvwxyz 67890\$

ABCDEFGHIJKLMN OPQRSTUVWXYZ

ABCDEFGHIJKLMN OPQRSTUVWXYZ

12345 abcdefghijklmnopqrstuvwxyz 67890\$

ABCDEFGHIJKLMN OPQRSTUVWXYZ

### MONOTYPE FACES

The very best kind of originality is that which comes after a thorough apprenticeship; that which shall prove to be the blending of a firm conception of all useful precedent and the progressive tendencies of an able mind. For, let a man be as able and original as he may, he cannot afford to discard knowledge of what has gone before or what is now going on in his own trade and profession. If the printers of today do not wish to be esteemed arrogant when they term this calling of theirs an art, they must be willing, and show that they are willing, to subject it to such laws as have made its sister arts so free. All those concerned in what are accepted as the fine arts, the learned sciences, and professions *surround themselves with the history, literature, and concrete examples of work with which they are*

12 Point No. 71E, 12 Set

### MONOTYPE FACES

The best kind of originality is that which comes after a sound apprenticeship; that which shall prove to be the blending of a firm conception of all useful precedent and the progressive tendencies of an able mind. For, let any man be as able and original as he may, he cannot afford to discard knowledge of what has gone before or what is now going on in his own trade and profession. If the printers of *today do not wish to be esteemed arrogant when they term this calling of theirs*

12345 abcdefghijklmnopqrstuvwxyz 67890\$

ABCDEFGHIJKLMN OPQRSTUVWXYZ

ABCDEFGHIJKLMN OPQRSTUVWXYZ

12345 abcdefghijklmnopqrstuvwxyz 67890\$

ABCDEFGHIJKLMN OPQRSTUVWXYZ

### MONOTYPE FACES

The best kind of originality is that which comes after a sound apprenticeship; that which shall prove to be the blending of a firm conception of all useful precedent and the progressive tendencies of an able mind. For, let any man be as able and original as he may, he cannot afford to discard knowledge of what has gone before or what is now going on in his own trade and profession. If the printers of today do not wish to be esteemed arrogant when they term this calling of theirs an art, they must be willing, and show that they are willing, to subject it to such laws

18 Point No. 71

**SAVES ELECTROTYPING EXPENSE**

The Monotype will put this Money in Your Own Pocket, Besides  
what You Save on New Type Bills

\$1234567890

24 Point No. 71

**ALL SPACES AND QUADS**

From 5 Point to 36 Point are Cast on the  
Monotype from Waste Metal

\$1234567890

30 Point No. 71

**60 EMS PICA**

The Unequalled Range of the Busy  
and Versatile Monotype

\$1234567890

36 Point No. 71

**NEW TYPE**

Think of it! Nothing but New  
Type for Every Job

\$1234567890



# No. 134E. Book Arrangement C

## Composition Matrices

6 Point No. 134E, 6 Set

### MONOTYPE FACES

The best kind of originality is that which comes after a sound apprenticeship; that which shall prove to be the blending of a firm conception of all useful precedent and the progressive tendencies of an able mind. For, let a man be as able and original as he may, he cannot afford to discard knowledge of what has gone before or what is now going on in his own trade and profession. If the printers of today do not wish to be esteemed arrogant when they term this calling of theirs an art, they must be willing, and show that they are willing, to subject it to such laws as have made its sister arts so free. All those concerned in what are accepted as the fine arts, the learned sciences, and professions surround themselves with the history, literature, and concrete examples of the work with which they are particularly engaged. Yet it is only in rare instances that such an atmosphere, with its material appurtenances, is to be found in a printing office. Art does not flourish in hidden places, nor under restraint, nor in ignorance of what talent and genius have accomplished and are accomplishing throughout the world. For to follow precedent wisely does not mean to imitate slavishly one great exemplar, but to study all masters faithfully, letting their great achievements sink slowly into the mind in order that we may patiently derive from the richness of our acquired knowledge and organized system an attitude of our own. The sprightly minded young man, who with his first business breath projects the new and startling, inevitably becomes tiresome, and is driven to an early disappearance; while the slower, more solidly endowed student will at least spend as much of his time in avoiding mistakes as in evolving the brilliant schemes wherewith to dazzle his contemporaries. The best kind of originality is that which comes after a sound apprenticeship; that which shall prove to be the blending of a firm conception of all useful precedent and the progressive tendencies of an able mind. For, let a man be as able and original as he may, he cannot afford to discard knowledge of what has gone before or what is now going on in his own trade and profession. If the printers of today do not wish to be esteemed arrogant when they term this calling of theirs an art, they must be willing, and show that they are willing, to

abcdefghijklmnopqrstuvwxy  
ABCDEFGHIJKLMNopQRSTUVWXYZ  
ABCDEFGHIJKLMNopQRSTUVWXYZ  
\$1234567890

10 Point No. 134E, 9½ Set

### MONOTYPE FACES

The best kind of originality is that which comes after a sound apprenticeship; that which shall prove to be the blending of a firm conception of all useful precedent and the progressive tendencies of an able mind. For, let a man be as able and original as he may, he cannot afford to discard knowledge of what has gone before or what is now going on in his own trade and profession. If the printers of today do not wish to be esteemed too arrogant when they term this calling of theirs an art, they must be willing, and show that they are willing, to subject it to such laws as have made its sister arts so free. All those concerned in what are accepted as the fine arts, the learned sciences, and professions surround themselves with the history, literature, and concrete examples of the work with which they are particularly engaged. Yet it is only in rare instances that such an atmosphere, with all its material appurtenances, is to be found in a printing office. Art does not flourish in hidden places, nor under restraint, nor in ignorance of what talent and genius have accomplished and

abcdefghijklmnopqrstuvwxy  
ABCDEFGHIJKLMNopQRSTUVWXYZ  
ABCDEFGHIJKLMNopQRSTUVWXYZ  
\$1234567890

8 Point No. 134E, 8 Set

### MONOTYPE FACES

The best kind of originality is that which comes after a sound apprenticeship; that which shall prove to be the blending of a firm conception of all useful precedent and the progressive tendencies of an able mind. For, let a man be as able and original as he may, he cannot afford to discard knowledge of what has gone before or what is now going on in his own trade and profession. If the printers of today do not wish to be esteemed arrogant when they term this calling of theirs an art, they must be willing, and show that they are willing, to subject it to such laws as have made its sister arts so free. All those concerned in what are accepted as the fine arts, the learned sciences, and the professions surround themselves with the history, the literature, and concrete examples of the work with which they are more particularly engaged. Yet it is only in rare instances that such an atmosphere, with its material appurtenances, is to be found in a printing office. Art does not flourish in hidden places, nor under restraint, nor in ignorance of what talent and genius have accomplished and are accomplishing throughout the world. For to follow precedent wisely does not mean to imitate slavishly one great exemplar, but to study all masters faithfully, letting their great achievements sink slowly into the mind in order that we may

abcdefghijklmnopqrstuvwxy  
ABCDEFGHIJKLMNopQRSTUVWXYZ  
ABCDEFGHIJKLMNopQRSTUVWXYZ  
\$1234567890

12 Point No. 134E, 11½ Set

### MONOTYPE FACES

The best kind of originality is that which comes after a sound apprenticeship; that which shall prove to be the blending of a firm conception of all useful precedent and the progressive tendencies of an able mind. For, let any man be as able and original as he may, he cannot afford to discard knowledge of what has gone before or what is now going on in his own trade and profession. If the printers of today do not wish to be esteemed too arrogant when they term this calling of theirs an art, they must be willing, and show that they are willing, to subject it to such laws as have made its sister arts so free. All those concerned in what are accepted as the fine arts, the learned sciences, and the professions surround themselves with the history, the liter-

abcdefghijklmnopqrstuvwxy  
ABCDEFGHIJKLMNopQRSTUVWX  
ABCDEFGHIJKLMNopQRSTUVWXYZ  
\$1234567890

# No. 154E. Book Arrangement C

## Composition Matrices

8 Point No. 154E, 8½ Set

### MONOTYPE FACES

The best kind of originality is that which comes after a sound apprenticeship; that which shall prove to be the blending of a firm conception of all useful precedent and the progressive tendencies of an able mind. For, let a man be as able and original as he may, he cannot afford to discard knowledge of what has gone before or what is now going on in his own trade and profession. If the printers of today do not wish to be esteemed arrogant when they term this calling of theirs an art, they must be willing, and show that they are willing, to subject it to such laws as have made its sister arts so free. All those concerned in what are accepted as the fine arts, the learned sciences, and the professions surround themselves with the history, the literature, and concrete examples of the work with which they are particularly engaged. Yet it is only in very rare instances that such an atmosphere, with its material appurtenances, is to be found in a printing office. Art does not flourish in hidden places, nor under restraint, nor in ignorance of what talent and genius have accomplished and are now accomplishing throughout the world. For to follow precedent wisely does not mean to imitate slavishly one great exemplar, but to study all the masters faithfully, letting their great achievements sink slowly into

### MONOTYPE FACES

The best kind of originality is that which comes after a sound apprenticeship; that which shall prove to be the blending of a firm conception of all useful precedent and the progressive tendencies of an able mind. For, let a man be as able and original as he may, he cannot afford to discard knowledge of what has gone before or what is now going on in his own trade and profession. If the printers of today do not wish to be esteemed arrogant when they term this calling of theirs an art, they must be willing, and show that they are willing, to subject it to such laws as have made its sister arts so free. All those concerned in what are accepted as the fine arts, the learned sciences, and the professions surround themselves with the history, the literature, and concrete examples of the work with which they are particularly engaged. Yet it is only in very rare instances that such an atmosphere, with its material appurtenances, is to be found in a printing office. Art does not flourish in hidden places, nor under restraint, nor in ignorance of what talent and genius have accomplished and are now accomplishing throughout the world. For to follow precedent wisely does not mean to imitate slavishly one great exemplar, but to study all the masters faithfully, letting their great achievements sink slowly into the mind in order that we may patiently derive from the richness of our acquired knowledge and organized system an attitude of our own. The sprightly minded young man, who with his first business breath projects the new and startling, inevitably becomes tiresome, and is driven to an early

|       |                            |         |
|-------|----------------------------|---------|
| 12345 | abcdefghijklmnopqrstuvwxy  | 67890\$ |
|       | ABCDEFGHIJKLMNPOQRSTUVWXYZ |         |
|       | abcdefghijklmnopqrstuvwxy  |         |
| 12345 | abcdefghijklmnopqrstuvwxy  | 67890\$ |
|       | ABCDEFGHIJKLMNPOQRSTUVWXYZ |         |

# No. 157E. Book Arrangement C

## Composition Matrices

6 Point No. 157E, 7 Set

### MONOTYPE FACES

The best kind of originality is that which comes after a sound apprenticeship; that which shall prove itself to be the blending of a firm conception of useful precedent and the progressive tendencies of an able mind. For, let a man be as able and original as he may, he cannot afford to discard knowledge of what has gone before or what is now going on in his own trade and profession. If the printers of today do not wish to be esteemed arrogant when they term this calling of theirs an art, they must be willing, and show that they are willing, to subject it to such laws as have made its sister arts so free. All those concerned in what are accepted as the fine arts, the learned sciences, and professions surround themselves with the history, literature, and concrete examples of work with which they are particularly engaged. Yet it is only in rare instances that such an atmosphere, with its material appurtenances, is to be found in the printing office. Art does not flourish in the hidden places, nor under restraint, nor in ignorance of what talent and genius have accomplished and are now accomplishing throughout the world. For to follow precedent wisely does not mean to imitate slavishly one great exemplar, but to study all the masters faithfully, letting their great achievements sink slowly into the mind in order that we may patiently derive from the richness of our acquired knowledge and organized system an attitude of our own. The sprightly minded young man, who with his first business breath projects the new and startling, inevitably becomes tiresome, and is driven to an early disappearance; while the slower and more solidly endowed student will at least spend as much of his time in avoiding mistakes as in evolving brilliant schemes wherewith to dazzle his contemporaries. The best kind of originality is that which comes after a sound apprenticeship; that which shall prove itself to be the blending of a firm conception of all useful precedent and the progressive tendencies of an able mind. For, let any man be as able and original as he

12345      abcdefghijklmnopqrstuvwxyz      67890\$  
 ABCDEFGHIJKLMNOPQRSTUVWXYZ  
 ABCDEFGHIJKLMNOPQRSTUVWXYZ  
 12345      abcdefghijklmnopqrstuvwxyz      67890\$  
 ABCDEFGHIJKLMNOPQRSTUVWXYZ

10 Point No. 157E, 10½ Set

### MONOTYPE FACES

The best kind of originality is that which comes after a sound apprenticeship; that which shall prove to be the blending of a firm conception of all useful precedent and the progressive tendencies of an able mind. For, let a man be as able and original as he may, he cannot afford to discard knowledge of what has gone before or what is now going on in his own trade and profession. If the printers of today do not wish to be esteemed arrogant when they term this calling of theirs an art, they must be willing, and show that they are willing, to subject it to such laws as have made its sister arts so free. All those concerned in what are accepted as the fine arts, the learned sciences, and the professions surround themselves with the history, the literature, and concrete examples of the work with which they are particularly engaged. Yet it

12345      abcdefghijklmnopqrstuvwxyz      67890\$  
 ABCDEFGHIJKLMNOPQRSTUVWXYZ  
 ABCDEFGHIJKLMNOPQRSTUVWXYZ  
 12345      abcdefghijklmnopqrstuvwxyz      67890\$  
 ABCDEFGHIJKLMNOPQRSTUVWXYZ

8 Point No. 157E, 8½ Set

### MONOTYPE FACES

The best kind of originality is that which comes after a sound apprenticeship; that which shall prove to be the blending of a firm conception of all useful precedent and the progressive tendencies of an able mind. For, let a man be as able and original as he may, he cannot afford to discard knowledge of what has gone before or what is now going on in his own trade and profession. If the printers of today do not wish to be esteemed arrogant when they term this calling of theirs an art, they must be willing, and show that they are willing, to subject it to such laws as have made its sister arts so free. All those concerned in what are accepted as the fine arts, the learned sciences, and the professions surround themselves with the history, the literature, and concrete examples of the work with which they are particularly engaged. Yet it is only in very rare instances that such an atmosphere, with its material appurtenances, is to be found in a printing office. Art does not flourish in hidden places, nor under restraint, nor in ignorance of what talent and genius have accomplished and are now accomplishing throughout the world. For to follow all precedent wisely does not mean to imitate slavishly one great exemplar, but to study all masters faith-

12345      abcdefghijklmnopqrstuvwxyz      67890\$  
 ABCDEFGHIJKLMNOPQRSTUVWXYZ  
 ABCDEFGHIJKLMNOPQRSTUVWXYZ  
 12345      abcdefghijklmnopqrstuvwxyz      67890\$  
 ABCDEFGHIJKLMNOPQRSTUVWXYZ

11 Point No. 157E, 11 Set

### MONOTYPE FACES

The best kind of originality is that which comes after a sound apprenticeship; that which shall prove to be the blending of a firm conception of all useful precedent and the progressive tendencies of an able mind. For, let a man be as able and original as he may, he cannot afford to discard knowledge of what has gone before or what is now going on in his own trade and profession. If the printers of today do not wish to be esteemed too arrogant when they term this calling of theirs an art, they must be willing, and show that they are willing, to subject it to such laws as have made its sister arts so free. All those concerned in what are accepted as the fine arts, the learned sciences, and profes-

12345      abcdefghijklmnopqrstuvwxyz      67890\$  
 ABCDEFGHIJKLMNOPQRSTUVWXYZ  
 ABCDEFGHIJKLMNOPQRSTUVWXYZ  
 12345      abcdefghijklmnopqrstuvwxyz      67890\$  
 ABCDEFGHIJKLMNOPQRSTUVWXYZ

# No. 157E. Book Arrangement C

## Composition Matrices

12 Point No. 157E, 12 Set

### MONOTYPE FACES

The best kind of originality is that which comes after a sound apprenticeship; that which shall prove to be the blending of a firm conception of all useful precedent and the progressive tendencies of an able mind. For, let any man be as able and original as he may, he cannot afford to discard knowledge of what has gone before or what is now going on in his own trade and profession. If the printers of today do not wish to be esteemed arrogant when they term this calling of theirs an art, they must be willing, and show *that they are willing, to subject it to such laws as have made its sister arts so free.*

### MONOTYPE FACES

The best kind of originality is that which comes after a sound apprenticeship; that which shall prove to be the blending of a firm conception of all useful precedent and the progressive tendencies of an able mind. For, let any man be as able and original as he may, he cannot afford to discard knowledge of what has gone before or what is now going on in his own trade and profession. If the printers of today do not wish to be esteemed arrogant when they term this calling of theirs an art, they must be willing, and show that they are willing, to subject it to such laws as have made its sister arts so free. *All those concerned in what are accepted as the fine arts, the learned sciences, and the*

12345 abcdefghijklmnopqrstuvwxyz 67890\$

ABCDEFGHIJKLMNOPQRSTUVWXYZ

ABCDEFGHIJKLMNOPQRSTUVWXYZ

12345 abcdefghijklmnopqrstuvwxyz 67890\$

ABCDEFGHIJKLMNOPQRSTUVWXYZ

14 Point No. 157

THE STYLE DD KEYBOARD

In the Composing Room, on any Class of Work, is an Ordinary Style D  
Keyboard with a College Education

\$1234567890

18 Point No. 157

TWO SIZES OF TYPE

And Two Entirely Different Measures Are But a  
Small Part of Its Qualifications

\$1234567890

24 Point No. 157

“USE TYPE TO FILL”

Means With the DD That It Will Follow  
Your Instructions

\$1234567890

30 Point No. 157

THE OPERATOR

Finds His Work Is Made Easier  
Instead of Harder

\$1234567890

36 Point No. 157

THE OUTPUT

Is Often Nearly Doubled

\$1234567890

Composition Matrices

6 Point No. 172E, 7 Set

MONOTYPE FACES

The best kind of originality is that which comes after a sound apprenticeship; that which shall prove to be the blending of a firm conception of all useful precedent and the progressive tendencies of an able mind. For, let a man be as able and original as he may, he cannot afford to discard knowledge of what has gone before or what is now going on in his own trade or his profession. If the printers of today do not wish to be esteemed arrogant when they term this calling of theirs an art, they must be willing, and show that they are willing, to subject it to such laws as have made its sister arts so free. All those concerned in what are accepted as the fine arts, the learned sciences, and professions surround themselves with the history, literature, and concrete examples of the work with which they are particularly engaged. Yet it is only in rare instances that such an atmosphere, with its material appurtenances, is to be found in a printing office. Art does not flourish in hidden places, nor under restraint, nor in ignorance of what talent and genius have accomplished and are accomplishing throughout the world. For to follow precedent wisely does not mean to imitate slavishly one great exemplar, but to study all the masters faithfully, letting their great achievements sink slowly into the mind in order that we may patiently derive from the richness of our acquired knowledge and organized system an attitude of our own. The sprightly minded young man, who with his first business breath projects the new and startling, inevitably becomes tiresome, and is driven to an early disappearance; while the slower, more solidly endowed student will at least spend as much of his time in avoiding mistakes as in evolving brilliant schemes wherewith to dazzle his contemporaries. The best kind of originality is that which comes after a sound apprenticeship; that which shall prove to be the blending of a firm conception of all useful precedent and the progressive tendencies of an able mind. For, let a man be as able and original as he

|       |                            |         |
|-------|----------------------------|---------|
| 12345 | abcdefghijklmnopqrstuvwxyz | 67890\$ |
|       | ABCDEFGHIJKLMNOPQRSTUVWXYZ |         |
|       | abcdefghijklmnopqrstuvwxyz |         |
| 12345 | abcdefghijklmnopqrstuvwxyz | 67890\$ |
|       | ABCDEFGHIJKLMNOPQRSTUVWXYZ |         |

7 Point No. 172E, 8 Set

MONOTYPE FACES

The best kind of originality is that which comes after a sound apprenticeship; that which shall prove to be the blending of a firm conception of all useful precedent and the progressive tendencies of an able mind. For, let a man be as able and original as he may, he cannot afford to discard knowledge of what has gone before or what is now going on in his own trade and profession. If the printers of today do not wish to be esteemed arrogant when they term this calling of theirs an art, they must be willing, and show that they are willing, to subject it to such laws as have made its sister arts so free. All those concerned in what are accepted as the fine arts, the learned sciences, and the professions surround themselves with the history, literature, and concrete examples of the work with which they are particularly engaged. Yet it is only in rare instances that such an atmosphere, with its material appurtenances, is to be found in a printing office. Art does not flourish in hidden places, nor under restraint, nor in ignorance of what talent and genius have accomplished and are accomplishing throughout the world. For to follow precedent wisely does not mean to imitate slavishly one great exemplar, but to study all the masters faithfully, letting their great achievements sink slowly into the mind in order that we may patiently derive from the richness of our acquired knowledge and organized system an attitude of our own. The sprightly minded young man, who with his first business breath projects the new and startling, inevitably becomes tiresome, and is driven to an

|       |                            |         |
|-------|----------------------------|---------|
| 12345 | abcdefghijklmnopqrstuvwxyz | 67890\$ |
|       | ABCDEFGHIJKLMNOPQRSTUVWXYZ |         |
|       | abcdefghijklmnopqrstuvwxyz |         |
| 12345 | abcdefghijklmnopqrstuvwxyz | 67890\$ |
|       | ABCDEFGHIJKLMNOPQRSTUVWXYZ |         |

8 Point No. 172E, 8 1/2 Set

MONOTYPE FACES

The best kind of originality is that which comes after a sound apprenticeship; that which shall prove to be the blending of a firm conception of all useful precedent and the progressive tendencies of an able mind. For, let a man be as able and original as he may, he cannot afford to discard knowledge of what has gone before or what is now going on in his own trade and profession. If the printers of today do not wish to be esteemed arrogant when they term this calling of theirs an art, they must be willing, and show that they are willing, to subject it to such laws as have made its sister arts so free. All those concerned in what are accepted as the fine arts, the learned sciences, and the professions surround themselves with the history, the literature, and concrete examples of the work with which they may be particularly engaged. Yet it is only in rare instances that such an atmosphere, with its material appurtenances, is to be found in a printing office. Art does not flourish in hidden places, nor under restraint, nor in ignorance of what talent and genius have accomplished and are now accomplishing throughout the world. For to follow all precedent wisely does not mean to imitate slavishly one great exemplar, but to study all masters faithfully, letting their great achievements sink slowly into the mind in order that we may patiently derive from the richness

|       |                            |         |
|-------|----------------------------|---------|
| 12345 | abcdefghijklmnopqrstuvwxyz | 67890\$ |
|       | ABCDEFGHIJKLMNOPQRSTUVWXYZ |         |
|       | abcdefghijklmnopqrstuvwxyz |         |
| 12345 | abcdefghijklmnopqrstuvwxyz | 67890\$ |
|       | ABCDEFGHIJKLMNOPQRSTUVWXYZ |         |

9 Point No. 172E, 9 Set

MONOTYPE FACES

The best kind of originality is that which comes after a sound apprenticeship; that which shall prove to be the blending of a firm conception of all useful precedent and the progressive tendencies of an able mind. For, let a man be as able and original as he may, he cannot afford to discard knowledge of what has gone before or what is now going on in his own trade and profession. If the printers of today do not wish to be esteemed too arrogant when they term this calling of theirs an art, they must be willing, and show that they are willing, to subject it to such laws as have made its sister arts so free. All those concerned in what are accepted as the fine arts, the learned sciences, and the professions surround themselves with the history, the literature, and concrete examples of the work with which they may be particularly engaged. Yet it is only in rare instances that such an atmosphere, with its material appurtenances, is to be found in a printing office. Art does not flourish in hidden places, nor under restraint, nor in ignorance of what talent and genius have accomplished and are now accomplishing throughout the world. For to

|       |                            |         |
|-------|----------------------------|---------|
| 12345 | abcdefghijklmnopqrstuvwxyz | 67890\$ |
|       | ABCDEFGHIJKLMNOPQRSTUVWXYZ |         |
|       | abcdefghijklmnopqrstuvwxyz |         |
| 12345 | abcdefghijklmnopqrstuvwxyz | 67890\$ |
|       | ABCDEFGHIJKLMNOPQRSTUVWXYZ |         |

# No. 172E. Book Arrangement C

## Composition Matrices

10 Point No. 172E, 10 Set

### MONOTYPE FACES

The best kind of originality is that which comes after a sound apprenticeship; that which shall prove to be the blending of a firm conception of all useful precedent and the progressive tendencies of an able mind. For, let a man be as able and original as he may, he cannot afford to discard knowledge of what has gone before or what is now going on in his own trade and profession. If the printers of today do not wish to be esteemed arrogant when they term this calling of theirs an art, they must be willing, and show that they are willing, to subject it to such laws as have made its sister arts so free. All those who are concerned in what are accepted as the fine arts, the learned sciences, and the professions surround themselves with the history, literature, and concrete examples of the work with which they are particularly engaged. Yet it is *only in rare instances that such an atmosphere, with its material appurtenances, is to be found in*

12345 abcdefghijklmnopqrstuvwxyz 67890\$  
ABCDEFGHIJKLMNOPQRSTUVWXYZ

ABCDEFGHIJKLMNOPQRSTUVWXYZ

12345 abcdefgbijklmnopqrstuvwxyz 67890\$  
ABCDEFGHIJKLMNOPQRSTUVWXYZ

11 Point No. 172E, 11 Set

### MONOTYPE FACES

The best kind of originality is that which comes after a sound apprenticeship; that which shall prove to be the blending of a firm conception of all useful precedent and of the progressive tendencies of an able mind. For, let a man be as able and original as he may, he cannot afford to discard all knowledge of what has gone before or what is now going on in his own trade and profession. If the printers of today do not wish to be esteemed too arrogant when they term this calling of theirs an art, they must be willing, and show that they are willing, to subject it to such laws as have made its sister arts so free. All those who are concerned in what are accepted as the fine arts, the learned sciences, and the professions surround themselves with the history, the literature, and concrete examples of the work

12345 abcdefghijklmnopqrstuvwxyz 67890\$  
ABCDEFGHIJKLMNOPQRSTUVWXYZ

ABCDEFGHIJKLMNOPQRSTUVWXYZ

12345 abcdefgbijklmnopqrstuvwxyz 67890\$  
ABCDEFGHIJKLMNOPQRSTUVWXYZ

12 Point No. 172E, 12 Set

### MONOTYPE FACES

The best kind of originality is that which comes after a sound apprenticeship; that which shall prove to be the blending of a firm conception of all useful precedent and the progressive tendencies of an able mind. For, let a man be as able and as original as he may, he cannot afford to discard knowledge of what has gone before or what is now going on in his own trade and profession. *If the printers of today do not wish to be esteemed arrogant*

12345 abcdefghijklmnopqrstuvwxyz 67890\$  
ABCDEFGHIJKLMNOPQRSTUVWXYZ

ABCDEFGHIJKLMNOPQRSTUVWXYZ

12345 abcdefgbijklmnopqrstuvwxyz 67890\$  
ABCDEFGHIJKLMNOPQRSTUVWXYZ

### MONOTYPE FACES

The best kind of originality is that which comes after a sound apprenticeship; that which shall prove to be the blending of a firm conception of all useful precedent and the progressive tendencies of an able mind. For, let a man be as able and original as he may, he cannot afford to discard knowledge of what has gone before or what is now going on in his own trade and profession. If the printers of today do not wish to be esteemed arrogant when they term this calling of theirs an art, they must be willing, and show that

14 Point No. 172

**MATRIX LIBRARY MEMBERS**

Keep Fonts on Hand for Use When they Please as Long as They Please  
to Convert Idle Time into Money

\$1234567890

18 Point No. 172

**CHANGE OUR TYPE CASTER**

Into a Composing Machine when you Need it Without  
the Loss of a Single Penny

\$1234567890

24 Point No. 172

**THE MONOTYPE KEYBOARD**

It Separates Type Setting from Making  
and Casting Type

\$1234567890

30 Point No. 172

**SIMPLE JUSTIFICATION**

The width of every Character is  
Automatically Registered

\$1234567890

36 Point No. 172

**CHANGE THE FACE**

But not the Key Arrangement

\$1234567890



# No. 64J. Book Arrangement C

## Composition Matrices

6 Point No. 64J, 6 Set

### MONOTYPE FACES

The best kind of originality is that which comes after a sound apprenticeship; that which shall prove to be the blending of a firm conception of all useful precedent and the progressive tendencies of an able mind. For, let a man be as able and original as he may, he cannot afford to discard knowledge of what has gone before or what is now going on in his own trade and profession. If the printers of today do not wish to be esteemed arrogant when they term this calling of theirs an art, they must be willing, and show that they are willing, to subject it to such laws as have made its sister arts so free. All those concerned in what are accepted as the fine arts, the learned sciences and the professions, surround themselves with the history, literature, and concrete examples of the work with which they are particularly engaged. Yet it is only in rare instances that such an atmosphere, with its material appurtenances, is to be found in a printing office. Art does not flourish in hidden places, nor under restraint, nor in ignorance of what talent and genius have accomplished and are accomplishing throughout the world. For to follow precedent wisely does not mean to imitate slavishly one great exemplar, but to study all masters faithfully, letting their great achievements sink slowly into the mind in order that we may patiently derive from the richness of our acquired knowledge and organized system an attitude of our own. The sprightly minded young man, who with his first business breath projects the new and startling, inevitably becomes tiresome, and is driven to an early disappearance; while the slower, more solidly endowed student will at least spend as much of his time in avoiding mistakes as in evolving brilliant schemes wherewith to dazzle his contemporaries. The best kind of originality is that which comes after a sound apprenticeship; that which shall prove to be the blending of a firm conception of all useful precedent and the progressive tendencies of an able mind. For, let a man be as able and original as he may, he cannot afford to discard knowledge of what has gone before or what is now going on in his own trade and profession. If the printers of today do not wish to be esteemed arrogant when they term this calling of theirs an art, they must be willing, and show that they are willing, to subject it to such laws as have made its sister arts so free. All those concerned in what are accepted as the fine arts, the learned sciences and professions, surround

abcdefghijklmnopqrstuvwxyz

ABCDEFGHIJKLMNOPQRSTUVWXYZ

\$1234567890

10 Point No. 64J, 9 Set

### MONOTYPE FACES

The best kind of originality is that which comes after a sound apprenticeship; that which shall prove to be the blending of a firm conception of all useful precedent and the progressive tendencies of an able mind. For, let a man be as able and original as he may, he cannot afford to discard knowledge of what has gone before or what is now going on in his own trade and profession. If the printers of today do not wish to be esteemed arrogant when they term this calling of theirs an art, they must be willing, and show that they are willing, to subject it to such laws as have made its sister arts so free. All those concerned in what are accepted as the fine arts, the learned sciences and the professions, surround themselves with the history, literature, and concrete examples of the work with which they are particularly engaged. Yet it is only in rare instances that such an atmosphere, with its material appurtenances, is to be found in a printing office. Art does not flourish in hidden places, nor under restraint, nor in ignorance of what talent and genius have accomplished and are accomplishing throughout the world. For to follow precedent wisely does not mean to imitate slav-

abcdefghijklmnopqrstuvwxyz

ABCDEFGHIJKLMNOPQRSTUVWXYZ

\$1234567890

8 Point No. 64J, 7½ Set

### MONOTYPE FACES

The best kind of originality is that which comes after a sound apprenticeship; that which shall prove to be the blending of a firm conception of all useful precedent and the progressive tendencies of an able mind. For, let a man be as able and original as he may, he cannot afford to discard knowledge of what has gone before or what is now going on in his own trade and profession. If the printers of today do not wish to be esteemed arrogant when they term this calling of theirs an art, they must be willing, and show that they are willing, to subject it to such laws as have made its sister arts so free. All those concerned in what are accepted as the fine arts, the learned sciences and the professions, surround themselves with the history, the literature, and concrete examples of the work with which they are particularly engaged. Yet it is only in rare instances that such an atmosphere, with its material appurtenances, is to be found in a printing office. Art does not flourish in hidden places, nor under restraint, nor in ignorance of what talent and genius have accomplished and are accomplishing throughout the world. For to follow precedent wisely does not mean to imitate slavishly one great exemplar, but to study all masters faithfully, letting their great achievements sink slowly into the mind in order that we may patiently derive from the richness of our acquired knowledge and organized system an attitude of our own. The sprightly minded young man, who with his first business breath projects the new and startling, inevitably becomes tiresome, and is

abcdefghijklmnopqrstuvwxyz

ABCDEFGHIJKLMNOPQRSTUVWXYZ

\$1234567890

12 Point No. 64J, 10½ Set

### MONOTYPE FACES

The best kind of originality is that which comes after a sound apprenticeship; that which shall prove to be the blending of a firm conception of all useful precedent and the progressive tendencies of an able mind. For, let a man be as able and original as he may, he cannot afford to discard knowledge of what has gone before or what is now going on in his own trade and profession. If the printers of today do not wish to be esteemed arrogant when they term this calling of theirs an art, they must be willing, and show that they are willing, to subject it to such laws as have made its sister arts so free. All those concerned in what are accepted as the fine arts, the learned sciences and professions, surround themselves with the history, literature, and concrete examples of the work with which they are particularly engaged. Yet

abcdefghijklmnopqrstuvwxyz

ABCDEFGHIJKLMNOPQRSTUVWXYZ

\$1234567890

14 Point No. 64

**BETTER THAN FOUNDRY TYPE ONCE USED**  
Monotype Product is Always New. It is Always Ready to Print and Ready to  
Sell to your Satisfied Customer at a Profit  
\$1234567890

18 Point No. 64

**THE MONOTYPE WILL DO**  
Anything that a Compositor at the Case can do, and not only do  
it Better but will do it More Quickly  
\$1234567890

24 Point No. 64

**RAILROAD TARIFFS**  
And Intricate Tables Composed Exclusively on The  
Versatile and Accurate Monotype  
\$1234567890

30 Point No. 64

**FACE OR MEASURE**  
Changed Simply, Like Setting a Stick, and  
with Just as Much Speed  
\$1234567890

36 Point No. 64

**SAVES TYPE BILLS**  
And Time Lost Waiting for Sorts  
\$1234567890

# No. 64K. Book Arrangement C

## Composition Matrices

6 Point No. 64K, 6 Set

### MONOTYPE FACES

The best kind of originality is that which comes after a sound apprenticeship; that which shall prove to be the blending of a firm conception of all useful precedent and the progressive tendencies of an able mind. For, let a man be as able and original as he may, he cannot afford to discard knowledge of what has gone before or what is now going on in his own trade and profession. If the printers of today do not wish to be esteemed arrogant when they term this calling of theirs an art, they must be willing, and show that they are willing, to subject it to such laws as have made its sister arts so free. All those concerned in what are accepted as the fine arts, the learned sciences and the professions, surround themselves with the history, literature, and concrete examples of the work with which they are particularly engaged. Yet it is only in rare instances that such an atmosphere, with its material appurtenances, is to be found in a printing office. Art does not flourish in hidden places, nor under restraint, nor in ignorance of what talent and genius have accomplished and are now accomplishing throughout the world. For to follow precedent wisely does not mean to imitate slavishly one great exemplar, but to study all masters faithfully, letting their great achievements sink slowly into the mind in order that we may patiently derive from the richness of our acquired knowledge and organized system an attitude of our own. The sprightly minded young man, who with his first business breath projects the new and startling, inevitably becomes tiresome, and is driven to an early disappearance; while the slower, more solidly endowed student will at least spend as much of his time in avoiding mistakes as in evincing brilliant schemes wherewith to dazzle his contemporaries. The very best kind of originality is that which comes after a sound apprenticeship; that which shall prove to be the blending of a firm conception of all useful precedent and the progressive tendencies of an able mind. For, let any man be as able and original as he may, he cannot afford to discard knowledge of what has gone before or what is now going on in his own trade and profession. If the printers of today do not wish to be esteemed too arrogant when they term this calling of theirs an art, they must be willing, and show that they are willing, to subject it to such laws as have made its sister arts so free. All those concerned in what are accepted as the fine arts, the learned sciences and professions, surround themselves with the history, literature, and concrete examples of the work with which they are particularly engaged. Yet it is only in rare instances

abcdefghijklmnopqrstuvwxyz

ABCDEFGHIJKLMN OPQRSTUVWXYZ

\$1234567890

8 Point No. 64K, 7½ Set

### MONOTYPE FACES

The best kind of originality is that which comes after a sound apprenticeship; that which shall prove to be the blending of a firm conception of all useful precedent and the progressive tendencies of an able mind. For, let any man be as able and original as he may, he cannot afford to discard all knowledge of what has gone before or what is now going on in his own trade and profession. If the printers of today do not wish to be esteemed too arrogant when they term this calling of theirs an art, they must be willing, and also show that they are willing, to subject it to such laws as have made its sister arts so free. All those concerned in what are accepted as the fine arts, the learned sciences and professions, surround themselves with the history, literature, and concrete examples of the work with which they are particularly engaged. Yet it is only in rare instances that such an atmosphere, with its material appurtenances, is to be found in the printing office. Art does not flourish in hidden places, nor under restraint, nor in ignorance of what talent and genius have accomplished and are accomplishing throughout the world. For to follow precedent wisely does not mean to imitate slavishly one great exemplar, but to study all masters faithfully, letting their great achievements sink slowly into the mind in order that we may patiently derive from the very richness of our acquired knowledge and organized system an attitude of our own. The sprightly minded young man, who with his first business breath projects the new and startling, inevitably becomes tiresome, and is driven to an early disappearance; while the slower, more solidly endowed student will at least spend as much time

abcdefghijklmnopqrstuvwxyz

ABCDEFGHIJKLMN OPQRSTUVWXYZ

\$1234567890

10 Point No. 64K, 9 Set

### MONOTYPE FACES

The best kind of originality is that which comes after a sound apprenticeship; that which shall prove to be the blending of a firm conception of all useful precedent and the progressive tendencies of an able mind. For, let a man be as able and original as he may, he cannot afford to discard knowledge of what has gone before or what is now going on in his own trade and profession. If the printers of today do not wish to be esteemed too arrogant when they term this calling of theirs an art, they must be willing, and show that they are willing, to subject it to such laws as have made its sister arts so free. All those concerned in what are accepted as the fine arts, the learned sciences and professions, surround themselves with the history, literature, and concrete examples of the work with which they are particularly engaged. Yet it is only in rare instances that such an atmosphere, with its material appurtenances, is to be found in a printing office. Art does not flourish in hidden places, nor under restraint, nor in ignorance of what talent and genius have accomplished and are accomplishing throughout the world. For to follow precedent wisely does not mean to imitate slavishly one great exemplar, but to study all masters faithfully, letting

abcdefghijklmnopqrstuvwxyz

ABCDEFGHIJKLMN OPQRSTUVWXYZ

\$1234567890

12 Point No. 64K, 10½ Set

### MONOTYPE FACES

The best kind of originality is that which comes after a sound apprenticeship; that which shall prove to be the blending of a firm conception of all useful precedent and the progressive tendencies of an able mind. For, let a man be as able and original as he may, he cannot afford to discard knowledge of what has gone before or what is now going on in his own trade and profession. If the printers of today do not wish to be esteemed arrogant when they term this calling of theirs an art, they must be willing, and show that they are willing, to subject it to such laws as have made its sister arts so free. All those concerned in what are accepted as the fine arts, the learned sciences, and the professions, surround themselves with the history, literature, and concrete examples of the work with which they are particularly engaged. Yet it is only in very rare instances that such an

abcdefghijklmnopqrstuvwxyz

ABCDEFGHIJKLMN OPQRSTUVWXYZ

\$1234567890

14 Point No. 641

**THE MONOTYPE PROTECTS YOUR FUTURE**  
*For some day You will want to Make Type on the Galley in Justified Lines  
instead of for the Case*  
**\$1234567890**

18 Point No. 641

**TYPE CASTER TIPS**  
*See that the Mold as well as the Machine is thoroughly Water  
Cooled like the Versatile Monotype*  
**\$1234567890**

24 Point No. 641

**A SELF-CONTAINED MOLD**  
*That's just the kind we furnish with the Monotype  
It Maintains Accuracy*  
**\$1234567890**

30 Point No. 641

**FREE MONOTYPE SCHOOL**  
*Ambitious Compositors Can Make Better  
Pay and Work Shorter Hours*  
**\$1234567890**

36 Point No. 641

**THE MACHINE**  
*That Makes the Type Trust Peevish*  
**\$1234567890**

# No. 164J. Book Arrangement C

## Composition Matrices

6 Point No. 164J, 7 Set

### MONOTYPE FACES

The best kind of originality is that which comes after a sound apprenticeship; that which shall prove itself to be the blending of a firm conception of useful precedent and the progressive tendencies of an able mind. For, let a man be as able and original as he may, he cannot afford to discard knowledge of what has gone before or what is now going on in his own trade and profession. If the printers of today do not wish to be esteemed arrogant when they term this calling of theirs an art, they must be willing, and show that they are willing, to subject it to such laws as have made its sister arts so free. All those concerned in what are accepted as the fine arts, the learned sciences, and professions surround themselves with the history, literature, and concrete examples of the work with which they are particularly engaged. Yet it is only in rare instances that such an atmosphere, with its material appurtenances, is to be found in a printing office. Art does not flourish in hidden places, nor under restraint, nor in ignorance of what talent and genius have accomplished and are accomplishing throughout the world. FOR TO FOLLOW PRECEDENT WISELY DOES NOT MEAN TO IMITATE SLAVISHLY ONE GREAT EXEMPLAR, BUT TO STUDY ALL MASTERS FAITHFULLY, LETTING THEIR GREAT ACHIEVEMENTS SINK

\$12345      abcdefghijklmnopqrstuvwxyz      67890  
ABCDEF GHIJ KLMNOPQRSTUVWXYZ  
ABCDEF GHIJ KLMNOPQRSTUVWXYZ

7 Point No. 164J, 8 Set

### MONOTYPE FACES

The best kind of originality is that which comes after a sound apprenticeship; that which shall prove to be the blending of a firm conception of all useful precedent and the progressive tendencies of an able mind. For, let a man be as able and original as he may, he cannot afford to discard knowledge of what has gone before or what is now going on in his own trade and profession. If the printers of today do not wish to be esteemed arrogant when they term this calling of theirs an art, they must be willing, and show that they are willing, to subject it to such laws as have made its sister arts so free. All those concerned in what are accepted as the fine arts, the learned sciences, and the professions surround themselves with the history, literature, and the concrete examples of the work with which they are particularly engaged. YET IT IS ONLY IN RARE INSTANCES THAT SUCH AN ATMOSPHERE, WITH ITS MATERIAL APPURTENANCES, IS TO BE FOUND IN A

\$12345      abcdefghijklmnopqrstuvwxyz      67890  
ABCDEF GHIJ KLMNOPQRSTUVWXYZ  
ABCDEF GHIJ KLMNOPQRSTUVWXYZ

8 Point No. 164J, 8½ Set

### MONOTYPE FACES

The best kind of originality is that which comes after a sound apprenticeship; that which shall prove to be the blending of a firm conception of all useful precedent and the progressive tendencies of an able mind. For, let a man be as able and original as he may, he cannot afford to discard knowledge of what has gone before or what is now going on in his own trade and profession. If the printers of today do not wish to be esteemed arrogant when they term this calling of theirs an art, they must be willing, and show that they are willing, to subject it to such laws as have made its sister arts so free. ALL THOSE CONCERNED IN WHAT ARE ACCEPTED AS THE FINE ARTS, THE LEARNED SCIENCES, AND THE PROFESSIONS

\$12345      abcdefghijklmnopqrstuvwxyz      67890  
ABCDEF GHIJ KLMNOPQRSTUVWXYZ  
ABCDEF GHIJ KLMNOPQRSTUVWXYZ

10 Point No. 164J, 10 Set

### MONOTYPE FACES

The best kind of originality is that which comes after a sound apprenticeship; that which shall prove to be the blending of a firm conception of all useful precedent and the progressive tendencies of an able mind. For, let a man be as able and original as he may, he cannot afford to discard knowledge of what has gone before or what is now going on in his own trade and profession. If the printers of today do not wish to be esteemed too arrogant when they term this calling of theirs an art, they must be willing, and show that they are willing, to subject it to such laws as have made its sister arts so free. All those concerned in what are accepted as the fine arts, the learned sciences and the professions, surround themselves with the history, literature, AND CONCRETE EXAMPLES OF THE WORK WITH WHICH THEY ARE PARTICULARLY ENGAGED. YET IT IS ONLY IN RARE INSTANCES THAT SUCH AN ATMOSPHERE, WITH ALL ITS MATERIAL APPURTEN-

\$12345      abcdefghijklmnopqrstuvwxyz      67890  
ABCDEF GHIJ KLMNOPQRSTUVWXYZ  
ABCDEF GHIJ KLMNOPQRSTUVWXYZ

12 Point No. 164J, 12 Set

### MONOTYPE FACES

The best kind of originality is that which comes after a sound apprenticeship; that which shall prove to be the blending of a firm conception of all useful precedent and the progressive tendencies of an able mind. For, let any man be as able and original as he may, he cannot afford to discard knowledge of what has gone before or what is now going on in his own trade and profession. If the printers of today do not wish to be esteemed arrogant when they term this calling of theirs AN ART, THEY MUST BE WILLING, AND ALSO SHOW THAT THEY ARE WILLING, TO SUBJECT IT TO SUCH LAWS AS HAVE MADE

abcdefghijklmnopqrstu vwxyz  
ABCDEFGHIJ KLMNOPQRSTU VWX  
ABCDEFGHIJ KLMNOPQRSTU VWXYZ  
\$1234567890

14 Point No. 164

**MONOTYPE LOW QUADS AND SPACES**

Save Time in the Press Room on Make-ready and Running, and makes  
the Job Profitable for the Boss

\$1234567890

18 Point No. 164

**INTELLIGENT COMPOSITORS**

Learn to Operate the Monotype. It is the Most Productive  
and Healthful Composing Room Work

\$1234567890

24 Point No. 164

**GAS AND METAL FUMES**

Do Not Belong to the Composing Room in the  
Monotype Printing Shop

\$1234567890

30 Point No. 164

**NO PIECED SLUGS**

Or Sawing, Corrections Made the Same  
as with Foundry Type

\$1234567890

36 Point No. 164

**SEVEN ALPHABETS**

At Your Operator's Command

\$1234567890

# No. 164K. Book Arrangement C [Italic]

## Composition Matrices

6 Point No. 164K, 7 Set

### MONOTYPE FACES

*The best kind of originality is that which comes after a sound apprenticeship; that which shall prove itself to be the blending of a firm conception of useful precedent and the progressive tendencies of an able mind. For, let a man be as able and original as he may, he cannot afford to discard knowledge of what has gone before or what is now going on in his own trade and profession. If the printers of today do not wish to be esteemed arrogant when they term this calling of theirs an art, they must be willing, and show that they are willing, to subject it to such laws as have made its sister arts so free. All those concerned in what are accepted as the fine arts, the learned sciences, and professions surround themselves with the history, literature, and concrete examples of work with which they are particularly engaged. Yet it is only in very rare instances that such an atmosphere, with its material appurtenances, is to be found in the printing office. Art does not flourish in hidden places, nor under restraint, nor in ignorance of what talent and genius have accomplished and are accomplishing throughout the world. For to follow precedent wisely does not mean to imitate slavishly one great exemplar, but to study all the masters faithfully, letting their great achievements sink slowly into the mind in order that we may patiently derive from the richness of our acquired knowledge and organized system an attitude of our own. The sprightly minded young man, who with his first business breath projects the new and startling, inevitably becomes tiresome, and is driven to an early disappearance; while the slower and more solidly endowed student will at least spend as much of his time in avoiding mistakes as in evading brilliant schemes wherewith to dazzle his contemporaries. The best kind of originality is that which comes after a sound apprenticeship; that which shall prove to be the blending of a firm conception of all useful precedent and the progressive tendencies of an able mind. For, let any man be as able and original as he may, he cannot afford to discard knowledge of what has gone before or what is now going on in his own trade and profession. If the printers of today do not wish to be esteemed arrogant when they term this calling of theirs an art, they must be*

abcdefghijklmnopqrstuvwxyz

ABCDEFGHIJKLMNOPQRSTUVWXYZ

\$1234567890

10 Point No. 164K, 10 Set

### MONOTYPE FACES

*The best kind of originality is that which comes after a sound apprenticeship; that which shall prove to be the blending of a firm conception of all useful precedent and the progressive tendencies of an able mind. For, let a man be as able and original as he may, he cannot afford to discard knowledge of what has gone before or what is now going on in his own trade and profession. If the printers of today do not wish to be esteemed arrogant when they term this calling of theirs an art, they must be willing, and show that they are willing, to subject it to such laws as have made its sister arts so free. All those who are concerned in what are accepted as the fine arts, the learned sciences, and the professions surround themselves with the history, the literature, and concrete examples of the work with which they are particularly engaged. Yet it is only in rare instances that such an atmosphere, with its material appurtenances, is to be found in a printing office. Art does not flourish in hidden places, nor under restraint, nor in ignorance of what talent and genius have accomplished and are now accomplishing in*

abcdefghijklmnopqrstuvwxyz

ABCDEFGHIJKLMNOPQRSTUVWXYZ

\$1234567890

8 Point No. 164K, 8½ Set

### MONOTYPE FACES

*The best kind of originality is that which comes after a sound apprenticeship; that which shall prove to be the blending of a firm conception of all useful precedent and the progressive tendencies of an able mind. For, let a man be as able and original as he may, he cannot afford to discard knowledge of what has gone before or what is now going on in his own trade and profession. If the printers of today do not wish to be esteemed arrogant when they term this calling of theirs an art, they must be willing, and show that they are willing, to subject it to such laws as have made its sister arts so free. All those concerned in what are accepted as the fine arts, the learned sciences, and the professions surround themselves with the history, the literature, and concrete examples of the work with which they are particularly engaged. Yet it is only in very rare instances that such an atmosphere, with its material appurtenances, is to be found in a printing office. Art does not flourish in hidden places, nor under restraint, nor in ignorance of what talent and genius have accomplished and are now accomplishing throughout the world. For to follow all precedent wisely does not mean to imitate slavishly one great exemplar, but to study all masters faithfully, letting their great achievements sink slowly into the mind in order that we may patiently derive from the richness of our acquired knowledge and organized system an attitude of our own. The*

abcdefghijklmnopqrstuvwxyz

ABCDEFGHIJKLMNOPQRSTUVWXYZ

\$1234567890

12 Point No. 164K, 12 Set

### MONOTYPE FACES

*The best kind of originality is that which comes after a sound apprenticeship; that which shall prove to be the blending of a firm conception of all useful precedent and the progressive tendencies of an able mind. For, let any man be as able and original as he may, he cannot afford to discard knowledge of what has gone before or what is now going on in his own trade and profession. If the printers of today do not wish to be esteemed arrogant when they term this calling of theirs an art, they must be willing, and show that they are willing, to subject it to such laws as have made its sister arts so free. All those who are concerned in what are accepted as the fine arts, the learned sciences, and the professions surround themselves with the history, the liter-*

abcdefghijklmnopqrstuvwxyz

ABCDEFGHIJKLMNOPQRSTUVWXYZ

\$1234567890

14 Point No. 1641

**THE MONOTYPE IS MUCH MORE**

*Than a Composing Machine, it is also a Complete Type Foundry. It  
Furnishes all Material for Hand Compositors*

**\$1234567890**

18 Point No. 1641

**IT HAS BEEN PROVED**

*Repeatedly that it is Impossible to get Efficiency From  
Compositors Using Bought Type*

**\$1234567890**

24 Point No. 1641

**THE MONOTYPE**

*System Increases the Efficiency of Every  
Composing-Room Employee*

**\$1234567890**

30 Point No. 1641

**NO MECHANICAL**

*Limitations Restrict the Designers  
of Monotype Faces*

**\$1234567890**

36 Point No. 1641

**GOOD RULE**

*Is a Product of the Monotype*

**\$1234567890**



# No. 264J. Book Arrangement C

## Composition Matrices

8 Point No. 264J, 6½ Set

### MONOTYPE FACES

The best kind of originality is that which comes after a sound apprenticeship; that which shall prove to be the blending of a firm conception of all useful precedent and the progressive tendencies of an able mind. For, let a man be as able and original as he may, he cannot afford to discard knowledge of what has gone before or what is now going on in his own trade or his profession. If the printers of today do not wish to be esteemed arrogant when they term this calling of theirs an art, they must be willing, and show that they are willing, to subject it to such laws as have made its sister arts so free. All those concerned in what are accepted as the fine arts, the learned sciences and the professions, surround themselves with the history, the literature, and concrete examples of the work with which they are particularly engaged. Yet it is only in very rare instances that such an atmosphere, with its material appurtenances, is to be found in a printing office. Art does not flourish in hidden places, nor under restraint, nor in ignorance of what talent and genius have accomplished and are now accomplishing throughout the world. For to follow precedent wisely does not mean to imitate slavishly one great exemplar, but to study all the masters faithfully, letting their great achievements sink slowly into the mind in order that we may patiently derive from the richness of our acquired knowledge and organized system an attitude of our own. The sprightly minded young man, who with his first business breath projects the new and startling, inevitably becomes tiresome, and is driven to an early disappearance; while the slower, more solidly endowed student will at least spend as much of his time in avoiding mistakes as in evolving brilliant schemes wherewith to dazzle his contemporaries. The

abcdefghijklmnopqrstuvwxy  
ABCDEFGHIJKLMNPOQRSTUVWXYZ  
\$1234567890

10 Point No. 264J, 8 Set

### MONOTYPE FACES

The best kind of originality is that which comes after a sound apprenticeship; that which shall prove to be the blending of a firm conception of all useful precedent and the progressive tendencies of an able mind. For, let a man be as able and original as he may, he cannot afford to discard knowledge of what has gone before or what is now going on in his own trade and profession. If the printers of today do not wish to be esteemed arrogant when they term this calling of theirs an art, they must be willing, and show that they are willing, to subject it to such laws as have made its sister arts so free. All those concerned in what are accepted as the fine arts, the learned sciences and the professions, surround themselves with the history, the literature, and concrete examples of the work with which they are particularly engaged. Yet it is only in very rare instances that such an atmosphere, with all its material appurtenances, is to be found in a printing office. Art does not flourish in hidden places, nor under restraint, nor in ignorance of what talent and genius have accomplished and are now accomplishing throughout the world. For to follow precedent wisely

abcdefghijklmnopqrstuvwxy  
ABCDEFGHIJKLMNPOQRSTUVWXYZ  
\$1234567890

12 Point No. 264J, 9½ Set

### MONOTYPE FACES

The best kind of originality is that which comes after a sound apprenticeship; that which shall prove to be the blending of a firm conception of all useful precedent and the progressive tendencies of an able mind. For, let a man be as able and original as he may, he cannot afford to discard knowledge of what has gone before or what is now going on in his own trade and profession. If the printers of today do not wish to be esteemed arrogant when they term this calling of theirs an art, they must be willing, and show that they are willing, to subject it to such laws as have made its sister arts so free. All those concerned in what are accepted as the fine arts, the learned sciences and the professions, surround themselves with the history, the literature, and concrete examples of the work with which they are particu-

abcdefghijklmnopqrstuvwxy  
ABCDEFGHIJKLMNPOQRSTUVWXYZ  
\$1234567890

### MONOTYPE FACES

The best kind of originality is that which comes after a sound apprenticeship; that which shall prove to be the blending of a firm conception of all useful precedent and the progressive tendencies of an able mind. For, let a man be as able and original as he may, he cannot afford to discard knowledge of what has gone before or what is now going on in his own trade and profession. If the printers of today do not wish to be esteemed arrogant when they term this calling of theirs an art, they must be willing, and show that they are willing, to subject it to such laws as have made its sister arts so free. All those concerned in what are accepted as the fine arts, the learned sciences and the professions, surround themselves with the history, the literature, and concrete examples of the work with which they are particularly engaged. Yet it is only in very rare instances that such an atmosphere, with all its material appurtenances, is to be found in a printing office. Art does not flourish in hidden places, nor under restraint, nor in ignorance of what talent and genius have accomplished and are now accomplishing throughout the world. For to follow precedent wisely

14 Point No. 264

**THIS IS AN AGE OF PRODUCTION**  
Keep Your Compositors Producing—Not Spending One-third Their Time Supplying  
Themselves with Material with which to Work  
\$1234567890

18 Point No. 264

**THEIR WORK IS CONSTRUCTIVE**  
Your Hand Compositors have spent Years of Diligent Labor to become  
Skilled at Their Trade  
\$1234567890

24 Point No. 264

**DON'T DISTRIBUTE**  
Let Your Compositors be Producers All the Time—  
They will Appreciate It  
\$1234567890

30 Point No. 264

**NEW MATERIAL**  
Compositors Need Full Cases of New Type and  
Plenty of New Rule  
\$1234567890

36 Point No. 264

**SAVE MONEY**  
On the Time Wasted for Distribution  
\$1234567890

# No. 86J. Job Arrangement C2

## Composition Matrices

5 Point No. 86J, 6 Set

### MONOTYPE FACES

The best kind of originality is that which comes after a sound apprenticeship; that which shall prove to be the blending of a firm conception of all useful precedent and the progressive tendencies of an able mind. For, let a man be as able and original as he may, he cannot afford to discard knowledge of what has gone before or what is now going on in his own trade and profession. If the printers of today do not wish to be esteemed arrogant when they term this calling of theirs an art, they must be willing, and show that they are willing, to subject it to such laws as have made its sister arts so free. All those concerned in what are accepted as the fine arts, the learned sciences, and professions surround themselves with the history, literature, and concrete examples of the work with which they are particularly engaged. Yet it is only in very rare instances that such an atmosphere, with its material appurtenances, is to be found in a printing office. Art does not flourish in hidden places, nor under restraint, nor even in ignorance of what talent and genius have accomplished and are accomplishing throughout the world. For to follow precedent wisely does not mean to imitate slavishly one great exemplar, but to study all masters faithfully, letting their great achievements sink slowly into the mind in order that we may patiently derive from the richness of our acquired knowledge and organized system an attitude of our own. The sprightly minded young man, who with his first business breath projects the new and startling, inevitably becomes tiresome, and is driven to an early disappearance; while the slower, more solidly endowed student will at least spend as much of his time in avoiding mistakes as in evolving brilliant schemes wherewith to dazzle his contemporaries. The best kind of originality is that which comes after a sound apprenticeship; that which shall prove to be the blending of a firm conception of all useful precedent and the progressive tendencies of an able mind. For, let a man be as able and original as he may, he cannot afford to discard knowledge of what has gone before or what is now going on in his own trade and profession. If the printers of today do not wish to be esteemed arrogant when they term this calling of theirs an art, they must be willing, and show that they are willing, to subject it to such laws as have made its sister arts so free. All those concerned in what are accepted as the fine arts, the learned sciences, and the professions surround themselves with the history, literature, and concrete examples of the work with which they are particularly engaged. Yet it is only in rare instances that such an atmosphere, with its material

abcdefghijklmnopqrstuvwxyz

ABCDEFGHIJKLMNOPQRSTUVWXYZ

\$1234567890

7 Point No. 86J, 8 Set

### MONOTYPE FACES

The best kind of originality is that which comes after a sound apprenticeship; that which shall prove to be the blending of a firm conception of all useful precedent and the progressive tendencies of an able mind. For, let a man be as able and original as he may, he cannot afford to discard knowledge of what has gone before or what is now going on in his own trade and profession. If the printers of today do not wish to be esteemed too arrogant when they term this calling of theirs an art, they must be willing, and show that they are willing, to subject it to such laws as have made its sister arts so free. All those concerned in what are accepted as the fine arts, the learned sciences, and the professions surround themselves with the history, the literature, and concrete examples of the work with which they are particularly engaged. Yet it is only in very rare instances that such an atmosphere, with its material appurtenances, is to be found in a printing office. Art does not flourish in the hidden places, nor under restraint, nor in ignorance of what talent and genius have accomplished and are now accomplishing throughout the world. For to follow precedent wisely does not mean to imitate slavishly one great exemplar, but to study all masters faithfully, letting their great achievements sink slowly into the mind in order that we may patiently derive from the richness of our acquired knowledge and organized system an attitude of our own. The sprightly minded young man, who with his first business breath projects the new and startling, inevitably becomes tiresome, and is driven to an early disappearance; while the slower, more solidly endowed

abcdefghijklmnopqrstuvwxyz

ABCDEFGHIJKLMNOPQRSTUVWXYZ

\$1234567890

6 Point No. 86J, 7 Set

### MONOTYPE FACES

The best kind of originality is that which comes after a sound apprenticeship; that which shall prove to be the blending of a firm conception of all useful precedent and the progressive tendencies of an able mind. For, let a man be as able and original as he may, he cannot afford to discard knowledge of what has gone before or what is now going on in his own trade and profession. If the printers of today do not wish to be esteemed arrogant when they term this calling of theirs an art, they must be willing, and show that they are willing, to subject it to such laws as have made its sister arts so free. All those concerned in what are accepted as the fine arts, the learned sciences, and professions surround themselves with the history, literature, and concrete examples of the work with which they are particularly engaged. Yet it is only in very rare instances that this atmosphere, with its material appurtenances, is to be found in a printing office. Art does not flourish in hidden places, nor under restraint, nor in ignorance of what talent and genius have accomplished and are accomplishing throughout the world. For to follow precedent wisely does not mean to imitate slavishly one great exemplar, but to study all masters faithfully, letting their great achievements sink slowly into the mind in order that we may patiently derive from the richness of our acquired knowledge and organized system an attitude of our own. The sprightly minded young man, who with his first business breath projects the new and startling, inevitably becomes tiresome, and is driven to an early disappearance; while the slower, more solidly endowed student will at least spend as much of his time in avoiding mistakes as in evolving brilliant schemes wherewith to dazzle his contemporaries. The best kind of originality is that which comes after a sound apprenticeship; that which shall prove to

abcdefghijklmnopqrstuvwxyz

ABCDEFGHIJKLMNOPQRSTUVWXYZ

\$1234567890

8 Point No. 86J, 8½ Set

### MONOTYPE FACES

The best kind of originality is that which comes after a sound apprenticeship; that which shall prove to be the blending of a firm conception of all useful precedent and the progressive tendencies of an able mind. For, let a man be as able and original as he may, he cannot afford to discard knowledge of what has gone before or what is now going on in his own trade and profession. If the printers of today do not wish to be esteemed arrogant when they term this calling of theirs an art, they must be willing, and show that they are willing, to subject it to such laws as have made its sister arts so free. All those concerned in what are accepted as the fine arts, the learned sciences, and professions surround themselves with the history, literature, and concrete examples of the work with which they are particularly engaged. Yet it is only in very rare instances that such an atmosphere, with its material appurtenances, is to be found in a printing office. Art does not flourish in hidden places, nor under restraint, nor in ignorance of what talent and genius have accomplished and are accomplishing throughout the world. For to follow precedent wisely does not mean to imitate slavishly one great exemplar, but to study all of the masters faithfully, letting their great achievements sink slowly into the mind in order that we may patiently derive from the rich-

abcdefghijklmnopqrstuvwxyz

ABCDEFGHIJKLMNOPQRSTUVWXYZ

\$1234567890

# No. 86J. Job Arrangement C2

## Composition Matrices

9 Point No. 86J, 9 Set

### MONOTYPE FACES

The best kind of originality is that which comes after a sound apprenticeship; that which shall prove to be the blending of a firm conception of all useful precedent and of the progressive tendencies of an able mind. For, let a man be as able and original as he may, he cannot afford to discard knowledge of what has gone before or what is now going on in his own trade and profession. If the printers of today do not wish to be esteemed arrogant when they term this calling of theirs an art, they must be willing, and show that they are willing, to subject it to such laws as have made its sister arts so free. All those concerned in what are accepted as the fine arts, the learned sciences, and professions surround themselves with the history, the literature, and concrete examples of the work with which they are particularly engaged. Yet it is only in rare instances that such an atmosphere, with its material appurtenances, is to be found in a printing office. Art does not flourish in hidden places, nor

abcdefghijklmnopqrstuvwxy  
ABCDEFGHIJKLMN OPQRSTUVWXYZ  
\$1234567890

11 Point No. 86J, 11 Set

### MONOTYPE FACES

The very best kind of originality is that which comes after a sound apprenticeship; that which shall prove itself to be the blending of a firm conception of all useful precedent and the progressive tendencies of an able mind. Let any man be as able and original as he may, he cannot afford to discard knowledge of what has gone before or what is now going on in his own trade and profession. If the printers of today do not wish to be esteemed arrogant when they term this calling of theirs an art, they must be willing, and show that they are willing, to subject it to such laws as have made its sister arts so free. All those concerned in what are accepted as the fine arts, the learned sciences, and professions surround themselves with the history, literature, and concrete exam-

abcdefghijklmnopqrstuvwxy  
ABCDEFGHIJKLMN OPQRSTUVWXYZ  
\$1234567890

10 Point No. 86J, 10½ Set

### MONOTYPE FACES

The best kind of originality is that which comes after a sound apprenticeship; that which shall prove to be the blending of a firm conception of all useful precedent and the progressive tendencies of an able mind. For, let any man be as able and original as he may, he cannot afford to discard knowledge of what has gone before or what is now going on in his own trade and profession. If the printers of today do not wish to be esteemed too arrogant when they term this calling of theirs an art, they must be willing, and show that they are willing, to subject it to such laws as have made its sister arts so very free. All those concerned in what are accepted as the fine arts, the learned sciences, and professions surround themselves with the history, literature, and concrete examples

abcdefghijklmnopqrstuvwxy  
ABCDEFGHIJKLMN OPQRSTUVWXYZ  
\$1234567890

12 Point No. 86J, 12 Set

### MONOTYPE FACES

The best kind of originality is that which comes after a sound apprenticeship; that which shall prove to be the blending of a firm conception of all useful precedent and the progressive tendencies of an able mind. For, let a man be as able and original as he may, he cannot afford to discard a knowledge of what has gone before or what is now going on in his own trade and profession. If the printers of today do not wish to be esteemed arrogant when they term this calling of theirs an art, they must be willing, and show that they are willing, to subject it to such laws as have made its sister arts so free. All those who are concerned in what

abcdefghijklmnopqrstuvwxy  
ABCDEFGHIJKLMN OPQRSTUVWXYZ  
\$1234567890

No. 86

Electro Display Matrices

14 Point No. 86

**BUILT ON THE UNIT SYSTEM**

**Like Elastic Filing Cabinets. Add the Units as You Want Them  
It Helps You Grow and Grows with You**

**\$1234567890**

18 Point No. 86

**DISPLAY TYPE AND BORDERS**

**Spaces and Quads can be Cast at a Minimum Cost for  
a High Quality Product**

**\$1234567890**

24 Point No. 86

**EASILY CORRECTED**

**Monotype Type is Corrected Like Foundry  
Type. No Machine Expense**

**\$1234567890**

30 Point No. 86

**TWO IN ONE**

**The Monotype is the Type Foundry  
Composing Machine**

**\$1234567890**

36 Point No. 86

**A LABOR SAVING**

**Profit-maker for all Printers**

**\$1234567890**

Composition Matrices

5 Point No. 86K, 6 Set

MONOTYPE FACES

The best kind of originality is that which comes after a sound apprenticeship; that which shall prove to be the blending of a firm conception of all useful precedent and the progressive tendencies of an able mind. For, let a man be as able and original as he may, he cannot afford to discard knowledge of what has gone before or what is now going on in his own trade or his profession. If the printers of today do not wish to be esteemed arrogant when they term this calling of theirs an art, they must be willing, and show that they are willing, to subject it to such laws as have made its sister arts so free. All those concerned in what are accepted as the fine arts, the learned sciences and professions, surround themselves with the history, the literature, and concrete examples of the work with which they are particularly engaged. Yet it is only in very rare instances that such an atmosphere, with its material appurtenances, is to be found in a printing office. Art does not flourish in hidden places, nor under restraint, nor in ignorance of what talent and genius have accomplished and are accomplishing throughout the world. For to follow all precedent wisely does not mean to imitate slavishly one great exemplar, but to study all masters faithfully, letting their great achievements sink slowly into the mind in order that we may patiently derive from the richness of our acquired knowledge and organized system an attitude of our own. The sprightly minded young man, who with his first business breath projects the new and startling, inevitably becomes tiresome and is driven to an early disappearance; while the slower, more solidly endowed student

abcdefghijklmnopqrstuvwxyz  
ABCDEFGHIJKLMNPOQRSTUVWXYZ  
\$1234567890

6 Point No. 86K, 7 Set

MONOTYPE FACES

The best kind of originality is that which comes after a sound apprenticeship; that which shall prove to be the blending of a firm conception of all useful precedent and the progressive tendencies of an able mind. For, let a man be as able and original as he may, he cannot afford to discard knowledge of what has gone before or what is now going on in his own trade or his profession. If the printers of today do not wish to be esteemed arrogant when they term this calling of theirs an art, they must be willing, and show that they are willing, to subject it to such laws as have made its sister arts so free. All those concerned in what are accepted as the fine arts, the learned sciences and professions, surround themselves with the history, the literature, and concrete examples of the work with which they are particularly engaged. Yet it is only in very rare instances that such an atmosphere, with its material appurtenances, is to be found in a printing office. Art does not flourish in hidden places, nor under restraint, nor in ignorance of what talent and genius have accomplished and are accomplishing throughout the world. For to follow all precedent wisely does not mean to imitate slavishly one great exemplar, but to study all masters faithfully, letting their great achievements sink slowly into the mind in order that we may patiently derive from the richness of our acquired knowledge and organized system an attitude of our own. The sprightly minded young man, who with his first business breath projects the new and startling, inevitably becomes tiresome and is driven to an early disappearance; while the slower, more solidly endowed student

abcdefghijklmnopqrstuvwxyz  
ABCDEFGHIJKLMNPOQRSTUVWXYZ  
\$1234567890

8 Point No. 86K, 8 1/2 Set

MONOTYPE FACES

The best kind of originality is that which comes after a thorough apprenticeship; that which shall prove to be the blending of a firm conception of all useful precedent and the progressive tendencies of an able mind. For, let a man be as able and original as he may, he cannot afford to discard knowledge of what has gone before or what is now going on in his own trade or his profession. If the printers of today do not wish to be esteemed arrogant when they term this calling of theirs an art, they must be willing, and show that they are willing, to subject it to such laws as have made its sister arts so free. All those concerned in what are accepted as the fine arts, the learned sciences, and professions, surround

abcdefghijklmnopqrstuvwxyz  
ABCDEFGHIJKLMNPOQRSTUVWXYZ  
\$1234567890

10 Point No. 86K, 10 1/2 Set

MONOTYPE FACES

The best kind of originality is that which comes after a thorough apprenticeship; that which shall prove to be the blending of a firm conception of all useful precedent and the progressive tendencies of an able mind. For, let a man be as able and original as he may, he cannot afford to discard knowledge of what has gone before or what is now going on in his own trade and profession. If the printers of today do not wish to be esteemed too arrogant when they term this calling of theirs an art, they must be willing, and show that they are willing, to subject it to such laws as have made its sister arts so free. All those concerned in what are accepted as the fine arts, the learned sciences and professions, surround themselves with the history, literature, and concrete examples of the work with which they are particularly engaged. Yet it is only

abcdefghijklmnopqrstuvwxyz  
ABCDEFGHIJKLMNPOQRSTUVWXYZ  
\$1234567890

12 Point No. 86K, 12 Set

MONOTYPE FACES

The best kind of originality is that which comes after a sound apprenticeship; that which shall prove to be the blending of a firm conception of all useful precedent and the progressive tendencies of an able mind. For, let a man be as able and original as he may, he cannot afford to discard a knowledge of what has gone before or what is now going on in his own trade and profession. If the printers of today do not wish to be esteemed arrogant when they term this calling of theirs an art, they must be willing, and show that they are willing, to subject it to such laws as have made its sister arts so free.

abcdefghijklmnopqrstuvwxyz  
ABCDEFGHIJKLMNPOQRSTUVWXYZ  
\$1234567890

14 Point No. 861

**MONOTYPE MATRIX EQUIPMENT**

*Greater than that of any other Machine; it enables its user to Make  
all of his own Type just when he wants it  
\$1234567890*

18 Point No. 861

**DON'T BUY A TYPE CASTER**

*If it doesn't supply every Typographical Requirement  
for all Varieties of Work  
\$1234567890*

24 Point No. 861

**FOUNDRY TYPE**

*Once Used is Never as Good as New Type  
Cast on the Monotype  
\$1234567890*

30 Point No. 861

**CUT OUT LOSSES**

*Due to Your Limited Facilities and  
Your Worn-out Faces  
\$1234567890*

36 Point No. 861

**FLEXIBILITY**

*Endless Matrix Combination  
\$1234567890*

# No. 186J. Job Arrangement C1

## Composition Matrices

5 Point No. 186J, 6 Set

### MONOTYPE FACES

The best kind of originality is that which comes after a sound apprenticeship; that which shall prove to be the blending of a firm conception of all useful precedent and the progressive tendencies of an able mind. For, let a man be as able and original as he may, he cannot afford to discard knowledge of what has gone before or what is now going on in his own trade and profession. If the printers of today do not wish to be esteemed arrogant when they term this calling of theirs an art, they must be willing, and show that they are willing, to subject it to such laws as have made its sister arts so free. All those concerned in what are accepted as the fine arts, the learned sciences, and professions surround themselves with the history, literature, and concrete examples of the work with which they are particularly engaged. Yet it is only in rare instances that such an atmosphere, with its material appurtenances, is to be found in a printing office. Art does not flourish in hidden places, nor under restraint, nor in ignorance of what talent and genius have accomplished and are now accomplishing throughout the world. For to follow precedent wisely does not mean to imitate slavishly one great exemplar, but to study all masters faithfully, letting their great achievements sink slowly into the mind in order that we may patiently derive from the richness of our acquired knowledge and organized system an attitude of our own. The sprightly minded young man, who with his first business breath projects the new and startling, inevitably becomes tiresome, and is driven to an early disappearance; while the slower, more solidly endowed student will at least spend as much of his time in avoiding mistakes as in evolving brilliant schemes wherewith to dazzle his contemporaries. The very best kind of originality is that which comes after a sound apprenticeship; that which shall prove to be the blending of a firm conception of all useful precedent and the progressive tendencies of an able mind. For, let a man be as able and original as he may, he cannot afford to discard knowledge of what has gone before or what is now going on in his own trade and profession. If the printers of today do not wish to be esteemed arrogant when they term this calling of theirs an art, they must be willing, and show that they are willing, to subject it to such laws as have made its sister arts so free. All those concerned in what are accepted as the fine arts, the learned sciences, and professions surround themselves with the history, literature, and concrete examples of the work with which they are particularly engaged. Yet it is only in rare instances that such an atmosphere, with its material appurtenances, is to be found in a printing office. Art does not flourish in hidden places, nor under restraint, nor in ignorance of what talent and genius have accomplished and are now accomplishing throughout the world. For to follow precedent wisely does not mean

abcdefghijklmnopqrstuvwxyz  
 ABCDEFGHIJKLMNOPQRSTUVWXYZ  
 \$1234567890

7 Point No. 186J, 8 Set

### MONOTYPE FACES

The best kind of originality is that which comes after a sound apprenticeship; that which shall prove itself to be the blending of a firm conception of useful precedent and the progressive tendencies of an able mind. For, let a man be as able and original as he may, he cannot afford to discard knowledge of what has gone before or what is now going on in his own trade and profession. If the printers of today do not wish to be esteemed arrogant when they term this calling of theirs an art, they must be willing, and show that they are willing, to subject it to such laws as have made its sister arts so free. All those concerned in what are accepted as the fine arts, the learned sciences, and the professions surround themselves with the history, the literature, and concrete examples of the work with which they are particularly engaged. Yet it is only in rare instances that such an atmosphere, with its material appurtenances, is to be found in a printing office. Art does not flourish in hidden places, nor under restraint, nor in ignorance of what talent and genius have accomplished and are now accomplishing throughout the world. For to follow precedent wisely does not mean to imitate slavishly one great exemplar, but to study all the masters faithfully, letting their great achievements sink slowly into the mind in order that we may patiently derive from the richness of our acquired knowledge and organized system an attitude of our own. The very sprightly minded young man, who with his first business breath projects the new and startling, inevitably becomes tiresome, and is driven to an early disappearance; while the slower, more solidly endowed student will at least spend as much of his time in avoiding mistakes as in evolving brilliant schemes wherewith to dazzle his contemporaries. The best

abcdefghijklmnopqrstuvwxyz  
 ABCDEFGHIJKLMNOPQRSTUVWXYZ  
 \$1234567890

6 Point No. 186J, 7 Set

### MONOTYPE FACES

The best kind of originality is that which comes after a sound apprenticeship; that which shall prove itself to be the blending of a firm conception of useful precedent and the progressive tendencies of an able mind. For, let a man be as able and original as he may, he cannot afford to discard knowledge of what has gone before or what is now going on in his own trade and profession. If the printers of today do not wish to be esteemed arrogant when they term this calling of theirs an art, they must be willing, and show that they are willing, to subject it to such laws as have made its sister arts so free. All those concerned in what are accepted as the fine arts, the learned sciences and professions, surround themselves with the history, literature, and concrete examples of the work with which they are particularly engaged. Yet it is only in rare instances that such an atmosphere, with its material appurtenances, is to be found in a printing office. Art does not flourish in hidden places, nor under restraint, nor in ignorance of what talent and genius have accomplished and are accomplishing throughout the world. For to follow precedent wisely does not mean to imitate slavishly one great exemplar, but to study all masters faithfully, letting their great achievements sink slowly into the mind in order that we may patiently derive from the richness of our acquired knowledge and organized system an attitude of our own. The sprightly minded young man, who with his first business breath projects the new and startling, inevitably becomes tiresome, and is driven to an early disappearance; while the slower, more solidly endowed student will at least spend as much of his time in avoiding mistakes as in evolving brilliant schemes wherewith to dazzle his contemporaries. The best kind of originality is that which comes after a sound apprenticeship; that which shall prove to be the blending of a firm conception of all useful precedent and the progressive tendencies of an able mind. For, let a man be as able and original as he may, he cannot afford to discard knowledge of what has gone before or what is now going on in his own trade and profession.

abcdefghijklmnopqrstuvwxyz  
 ABCDEFGHIJKLMNOPQRSTUVWXYZ  
 \$1234567890

8 Point No. 186J, 8½ Set

### MONOTYPE FACES

The best kind of originality is that which comes after a sound apprenticeship; that which shall prove to be the blending of a firm conception of all useful precedent and the progressive tendencies of an able mind. For, let a man be as able and original as he may, he cannot afford to discard knowledge of what has gone before or what is now going on in his own trade and profession. If the printers of today do not wish to be esteemed arrogant when they term this calling of theirs an art, they must be willing, and show that they are willing, to subject it to such laws as have made its sister arts so free. All those concerned in what are accepted as the fine arts, the learned sciences and professions, surround themselves with the history, the literature, and concrete examples of the work with which they are particularly engaged. Yet it is only in rare instances that such an atmosphere, with its material appurtenances, is to be found in a printing office. Art does not flourish in hidden places, nor under restraint, nor in ignorance of what talent and genius have accomplished and are now accomplishing throughout the world. For to follow precedent wisely does not mean to imitate slavishly one great exemplar, but to study all the masters faithfully, letting their great achievements sink slowly into the mind in order that we may patiently derive from the richness of our acquired knowledge and organized system an attitude of our own. The sprightly minded young man, who with his first business breath projects the new and

abcdefghijklmnopqrstuvwxyz  
 ABCDEFGHIJKLMNOPQRSTUVWXYZ  
 \$1234567890



# No. 186J. Job Arrangement C1

## Composition Matrices

9 Point No. 186J, 9 Set

### MONOTYPE FACES

The best kind of originality is that which comes after a sound apprenticeship; that which shall prove to be the blending of a firm conception of all useful precedent and the progressive tendencies of an able mind. For, let a man be as able and original as he may, he cannot afford to discard knowledge of what has gone before or what is now going on in his own trade and profession. If the printers of today do not wish to be esteemed arrogant when they term this calling of theirs an art, they must be willing, and show that they are willing, to subject it to such laws as have made its sister arts so free. All those concerned in what are accepted as the fine arts, the learned sciences and professions, surround themselves with the history, the literature, and concrete examples of the work with which they may be particularly engaged. Yet it is only in rare instances that such an atmosphere, with all its material appurtenances, is to be found in the printing office. Art does not flourish in hidden places, nor under restraint, nor in ignorance of what talent and genius have accomplished and are now accomplishing throughout the world. For to follow precedent wisely does not mean to imitate slavishly one great exemplar, but to study all

abcdefghijklmnopqrstuvwxy

ABCDEFGHIJKLMNPOQRSTUVWXYZ

\$1234567890

10 Point No. 186J, 10 Set

### MONOTYPE FACES

The best kind of originality is that which comes after a sound apprenticeship; that which shall prove to be the blending of a firm conception of all useful precedent and the progressive tendencies of an able mind. For, let a man be as able and original as he may, he cannot afford to discard knowledge of what has gone before or what is now going on in his own trade and profession. If the printers of today do not wish to be esteemed arrogant when they term this calling of theirs an art, they must be willing, and show that they are willing, to subject it to such laws as have made its sister arts so free. All those concerned in what are accepted as the fine arts, the learned sciences, and professions surround themselves with the history, literature, and concrete examples of the work with which they are particularly engaged. Yet it is only in rare instances that such an atmosphere, with its material appurtenances, is to be found in a printing office. Art does not flourish in hidden places

abcdefghijklmnopqrstuvwxy

ABCDEFGHIJKLMNPOQRSTUVWXYZ

\$1234567890

11 Point No. 186J, 11 Set

### MONOTYPE FACES

The best kind of originality is that which comes after a sound apprenticeship; that which shall prove to be the blending of a firm conception of all useful precedent and the progressive tendencies of an able mind. For, let any man be as able and original as he may, he cannot afford to discard knowledge of what has gone before or what is now going on in his own trade and profession. If the printers of today do not wish to be esteemed too arrogant when they term this calling of theirs an art, they must be willing, and show that they are willing, to subject it to such laws as have made its sister arts so free. All those concerned in what are accepted as the fine arts, the learned sciences and professions, surround themselves with

abcdefghijklmnopqrstuvwxy

ABCDEFGHIJKLMNPOQRSTUVWXYZ

\$1234567890

12 Point No. 186J, 12 Set

### MONOTYPE FACES

The best kind of originality is that which comes after a sound apprenticeship; that which shall prove to be the blending of a firm conception of all useful precedent and the progressive tendencies of an able mind. For, let any man be as able and original as he may, he cannot afford to discard knowledge of what has gone before or what is now going on in his own trade and profession. If the printers of today do not wish to be esteemed too arrogant when they term this calling of theirs an art, they must be willing, and show that they are willing, to subject it to such laws as have made its sister arts so free. All those concerned in what are

abcdefghijklmnopqrstuvwxy

ABCDEFGHIJKLMNPOQRSTUVWXYZ

\$1234567890

14 Point No. 186

**NO PRINTER CAN AFFORD  
To Refuse to Investigate advantages of the Monotype Non-Distribution  
System, which is Indorsed by Hundreds of Users  
\$1234567890**

18 Point No. 186

**THE MONOTYPE  
Eliminates Non-productive Time in the Composing Room  
and Increases Output in Press Room  
\$1234567890**

24 Point No. 186

**MANY MAGAZINES  
of Latin Europe are Produced entirely on the  
Monotype Composing Machine  
\$1234567890**

30 Point No. 186

**NON-DISTRIBUTION  
Reduces the Cost of producing Good  
Advertising Composition  
\$1234567890**

36 Point No. 186

**WORKMEN  
Will Appreciate Its Advantages  
\$1234567890**

# No. 88J. Job Arrangement C1

## Composition Matrices

5 Point No. 88J, 5 Set

### MONOTYPE FACES

The best kind of originality is that which comes after a sound apprenticeship; that which shall prove to be the blending of a firm conception of all useful precedent and the progressive tendencies of an able mind. For, let a man be as able and original as he may, he cannot afford to discard knowledge of what has gone before or what is now going on in his own trade and profession. If the printers of today do not wish to be esteemed arrogant when they term this calling of theirs an art, they must be willing, and show that they are willing, to subject it to such laws as have made its sister arts so free. All those concerned in what are accepted as the fine arts, the learned sciences, and professions surround themselves with the history, literature, and concrete examples of the work with which they are particularly engaged. Yet it is only in rare instances that such an atmosphere, with its material appertences, is to be found in a printing office. Art does not flourish in hidden places, nor under restraint, nor in ignorance of what talent and genius have accomplished and are now accomplishing throughout the world. For to follow precedent wisely does not mean to imitate slavishly one great exemplar, but to study all masters faithfully, letting their great achievements sink slowly into the mind in order that we may patiently derive from the richness of our acquired knowledge and organized systems an attitude of our own. The sprightly minded young men, who with

abcdefghijklmnopqrstuvwxy  
ABCDEFGHIJKLMNQPQRSTUVWXYZ  
\$1234567890

8 Point No. 88J, 7 Set

### MONOTYPE FACES

The best kind of originality is that which comes after a sound apprenticeship; that which shall prove itself to be the blending of a firm conception of useful precedent and the progressive tendencies of an able mind. For, let a man be as able and original as he may, he cannot afford to discard knowledge of what has gone before or what is now going on in his own trade and profession. If the printers of today do not wish to be esteemed arrogant when they term this calling of theirs an art, they must be willing, and show that they are willing, to subject it to such laws as have made its sister arts so free. All those concerned in what are accepted as the fine arts, the learned sciences, and professions surround themselves with the history, literature, and concrete examples of the work with which they are particularly engaged. Yet it is only in rare instances that such an atmosphere, with its ma-

abcdefghijklmnopqrstuvwxy  
ABCDEFGHIJKLMNQPQRSTUVWXYZ  
\$1234567890

6 Point No. 88J, 6 Set

### MONOTYPE FACES

The best kind of originality is that which comes after a sound apprenticeship; that which shall prove to be the blending of a firm conception of all useful precedent and the progressive tendencies of an able mind. For, let a man be as able and original as he may, he cannot afford to discard knowledge of what has gone before or what is now going on in his own trade and profession. If the printers of today do not wish to be esteemed arrogant when they term this calling of theirs an art, they must be willing, and show that they are willing, to subject it to such laws as have made its sister arts so free. All those concerned in what are accepted as the fine arts, the learned sciences, and professions surround themselves with the history, literature, and concrete examples of the work with which they are particularly engaged. Yet it is only in rare instances that such an atmosphere, with its material appertences, is to be found in a printing office. Art does not

abcdefghijklmnopqrstuvwxy  
ABCDEFGHIJKLMNQPQRSTUVWXYZ  
\$1234567890

10 Point No. 88J, 8 1/2 Set

### MONOTYPE FACES

The best kind of originality is that which comes after a sound apprenticeship; that which shall prove to be the blending of a firm conception of all useful precedent and the progressive tendencies of an able mind. For, let a man be as able and original as he may, he cannot afford to discard knowledge of what has gone before or what is now going on in his own trade and profession. If the printers of today do not wish to be esteemed arrogant when they term this calling of theirs an art, they must be willing, and show that they are willing, to subject it to

abcdefghijklmnopqrstuvwxy  
ABCDEFGHIJKLMNQPQRSTUVWXYZ  
\$1234567890

12 Point No. 88J, 10 Set

### MONOTYPE FACES

The best kind of originality is that which comes after a sound apprenticeship; that which shall prove to be the blending of a firm conception of all useful precedent and the progressive tendencies of an able mind. For, let a man be as able and original as he may, he cannot afford to discard knowledge of what has gone before or what is now going on in his own trade and profession. If the printers of today do not wish to be esteemed arrogant when they term this calling of theirs an art, they must be willing, and show that they are willing, to subject it to

abcdefghijklmnopqrstuvwxy  
ABCDEFGHIJKLMNQPQRSTUVWXYZ  
\$1234567890

### MONOTYPE FACES

The best kind of originality is that which comes after a sound apprenticeship; that which shall prove to be the blending of a firm conception of all useful precedent and the progressive tendencies of an able mind. For, let a man be as able and original as he may, he cannot afford to discard knowledge of what has gone before or what is now going on in his own trade and profession. If the printers of today do not wish to be esteemed arrogant when they term this calling of theirs an art, they must be willing, and show that they are willing, to subject it to such laws as have made its sister arts so free. All those concerned in what are accepted as the

14 Point No. 88

**GET A FAIR PRICE FOR YOUR WORK**

**You can Easily do this without being a Cost Expert by Building up Quality with a Monotype. The Work sells Itself at a Profit Making Price**

**\$1234567890**

18 Point No. 88

**ONE NEWSPAPER CUSTOMER SAYS**

**Since the Monotypes were Installed they haven't bought a Dollar's Worth of Type, Spacing Material or Borders**

**\$1234567890**

24 Point No. 88

**“PRINTING FOR PROFIT”**

**Is Our Answer to that Interesting Query, “What is the Matter with the Printing Business?”**

**\$1234567890**

30 Point No. 88

**QUALITY PAYS HANDSOMELY**

**It is the Best and Only Lever to Raise Prices and Increase Your Profits**

**\$1234567890**

36 Point No. 88

**ALL YOU CLAIM FOR IT**

**And More Says a Satisfied Monotyper**

**\$1234567890**

# No. 88K. Job Arrangement C1

## Composition Matrices

6 Point No. 88K, 6 Set

### MONOTYPE FACES

*The best kind of originality is that which comes after a sound apprenticeship; that which shall prove to be the blending of a firm conception of all useful precedent and the progressive tendencies of an able mind. For, let a man be as able and original as he may, he cannot afford to discard knowledge of what has gone before or what is now going on in his own trade and profession. If the printers of today do not wish to be esteemed arrogant when they term this calling of theirs an art, they must be willing, and show that they are willing, to subject it to such laws as have made its sister arts so free. All those concerned in what are accepted as the fine arts, the learned sciences, and professions surround themselves with the history, literature, and concrete examples of the work with which they are particularly engaged. Yet it is only in rare instances that such an atmosphere, with its material appurtenances, is to be found in a printing office. Art does not flourish in hidden places, nor under restraint, nor in ignorance of what talent and genius have accomplished and are now accomplishing throughout the world. For to follow precedent wisely does not mean to imitate slavishly one great exemplar, but to study all masters faithfully, letting their great achievements sink slowly into the mind in order that we may patiently derive from the richness of our acquired knowledge and organized system an attitude of our own. The sprightly minded young man, who with his first business breath projects the new and startling, inevitably becomes tiresome, and is driven to an early disappearance; while the slower, more solidly endowed student will at least spend as much of his time in avoiding mistakes as in evolving brilliant schemes wherewith to dazzle his contemporaries. The best kind of originality is that which comes after a sound apprenticeship; that which shall prove to be the blending of a firm conception of all useful precedent and the progressive tendencies of an able mind. For, let a man be as able and original as he may, he cannot afford to discard knowledge of what has gone before or what is now going on in his own trade and profession. If the printers of today do not wish to be esteemed arrogant when they term this calling of theirs an art, they must be willing, and show that they are willing, to subject it to such laws as have made its sister arts so free. All those concerned in what are accepted as the fine arts, the learned sciences, and*

abcdefghijklmnopqrstuvwxyz  
 ABCDEFGHIJKLMNOPQRSTUVWXYZ  
 \$1234567890

10 Point No. 88K, 8½ Set

### MONOTYPE FACES

*The best kind of originality is that which comes after a sound apprenticeship; that which shall prove to be the blending of a firm conception of all useful precedent and the progressive tendencies of an able mind. For, let a man be as able and original as he may, he cannot afford to discard knowledge of what has gone before or what is now going on in his own trade and profession. If the printers of today do not wish to be esteemed arrogant when they term this calling of theirs an art, they must be willing, and show that they are willing, to subject it to such laws as have made its sister arts so free. All those concerned in what are accepted as the fine arts, the learned sciences, and professions surround themselves with the history, the literature, and concrete examples of the work with which they may be particularly engaged. Yet it is only in rare instances that such an atmosphere, with its material appurtenances, is to be found in a printing office. Art does not flourish in hidden places, nor under restraint, nor in ignorance of what talent and genius have accomplished and are now accomplishing throughout the world. For to follow precedent wisely does not mean to imitate slavishly one great exemplar, but to study all the masters*

abcdefghijklmnopqrstuvwxyz  
 ABCDEFGHIJKLMNOPQRSTUVWXYZ  
 \$1234567890

8 Point No. 88K, 7 Set

### MONOTYPE FACES

*The best kind of originality is that which comes after a sound apprenticeship; that which shall prove itself to be the blending of a firm conception of useful precedent and the progressive tendencies of an able mind. For, let a man be as able and original as he may, he cannot afford to discard knowledge of what has gone before or what is now going on in his own trade and profession. If the printers of today do not wish to be esteemed arrogant when they term this calling of theirs an art, they must be willing, and show that they are willing, to subject it to such laws as have made its sister arts so free. All those concerned in what are accepted as the fine arts, the learned sciences, and professions surround themselves with the history, literature, and concrete examples of the work with which they are particularly engaged. Yet it is only in rare instances that such an atmosphere, with its material appurtenances, is to be found in a printing office. Art does not flourish in hidden places, nor under restraint, nor in ignorance of what talent and genius have accomplished and are accomplishing throughout the world. For to follow precedent wisely does not mean to imitate slavishly one great exemplar, but to study all masters faithfully, letting their great achievements sink slowly into the mind in order that we may patiently derive from the richness of our acquired knowledge and organized system an attitude of our own. The sprightly minded young man, who with his first business breath projects the new and startling, inevitably becomes tiresome, and is driven to an early disappearance; while the slower, more solidly endowed student will at least spend as*

abcdefghijklmnopqrstuvwxyz  
 ABCDEFGHIJKLMNOPQRSTUVWXYZ  
 \$1234567890

12 Point No. 88K, 10 Set

### MONOTYPE FACES

*The best kind of originality is that which comes after a sound apprenticeship; that which shall prove to be the blending of a firm conception of all useful precedent and the progressive tendencies of an able mind. For, let a man be as able and original as he may, he cannot afford to discard knowledge of what has gone before or what is now going on in his own trade and profession. If the printers of today do not wish to be esteemed arrogant when they term this calling of theirs an art, they must be willing, and show that they are willing, to subject it to such laws as have made its sister arts so free. All those concerned in what are accepted as the fine arts, the learned sciences, and professions surround themselves with the history, literature, and concrete examples of the work with which they are particularly engaged. Yet it is only in*

abcdefghijklmnopqrstuvwxyz  
 ABCDEFGHIJKLMNOPQRSTUVWXYZ  
 \$1234567890

No. 881

Electro Display Matrices

14 Point No. 881

**ALL ROMAN, ITALIC AND BOLD FACES**

*On Standard Monotype Line for all Point Sizes from 5 Point to 12 Point Inclusive  
can be cast to Line at One Operation*

**\$1234567890**

18 Point No. 881

**TWO-LINE OR THREE-LINE BOLD FACE FIGURES**

*Combined with any size Roman for Newspaper Ad. and Catalogue  
Work. This is not a Slug Makeshift*

**\$1234567890**

24 Point No. 881

**EXTRA CHARACTERS FOR SPECIAL WORK**

*Easily Inserted in the Monotype Flexible Matrix Case*

*No Extra Attachments Required*

**\$1234567890**

30 Point No. 881

**MONOTYPE MATRICES**

*Combined in an Endless Variety of Ways for  
an Endless Variety of Work*

**\$1234567890**

36 Point No. 881

**POINT, FACE & MEASURE**

*Quickly Changed with the Monotype*

**\$1234567890**

# No. 141J. Job Arrangement C1

## Composition Matrices

6 Point No. 141J, 5 Set

### MONOTYPE FACES

The best kind of originality is that which comes after a sound apprenticeship; that which shall prove to be the blending of a firm conception of all useful precedent and the progressive tendencies of an able mind. For, let a man be as able and original as he may, he cannot afford to discard knowledge of what has gone before or what is now going on in his own trade and profession. If the printers of today do not wish to be esteemed arrogant when they term this calling of theirs an art, they must be willing, and show that they are willing, to subject it to such laws as have made its sister arts so free. All those concerned in what are accepted as the fine arts, the learned sciences, and professions surround themselves with the history, literature, and concrete examples of the work which they are particularly engaged. Yet it is only in rare instances that such an atmosphere, with its material appurtenances, is to be found in a printing office. Art does not flourish in hidden places, nor under restraint, nor in ignorance of what talent and genius have accomplished and are accomplishing throughout the world. For to follow precedent wisely does not mean to imitate slavishly one great exemplar, but to study all masters faithfully, letting their great achievements sink slowly into the mind in order that we may patiently derive from the richness of our acquired knowledge and organized system an attitude of our own. The sprightly minded young man, who with his first business breath projects the new and startling, inevitably becomes tiresome, and is driven to an early disappearance; while the slower, more solidly endowed student will at least spend as much of his time in avoiding mistakes as in evolving brilliant schemes wherewith to dazzle his contemporaries. The best kind of originality is that which comes after a sound apprenticeship; that which shall prove to be the blending of a firm conception of all useful precedent and the progressive tendencies of an able mind. For, let a man be as able and original as he may, he cannot afford to discard knowledge of what has gone before or what is now going on in his own trade and profession. If the printers of today do not wish to be esteemed arrogant when they term this calling of theirs an art, they must be willing, and show that they are willing, to subject it to such laws as have made its sister arts so free. All those concerned in what are accepted as the fine arts, the learned sciences, and professions surround themselves with the history, literature, and concrete examples of the work with which they are particularly engaged. Yet it is only in rare instances that such an atmosphere, with its material appurtenances, is to be found in a printing office. Art does not flourish in hidden places, nor under restraint, nor in ignorance of what talent and genius have accomplished and are accomplishing throughout the world. For to follow precedent wisely does not mean to imitate slavishly one great exemplar, but to study all masters faithfully, letting their great achievements

abcdefghijklmnopqrstuvwxyz

ABCDEFGHIJKLMNQRSTUWXYZ

\$1234567890

10 Point No. 141J, 7 Set

### MONOTYPE FACES

The best kind of originality is that which comes after a sound apprenticeship; that which shall prove itself to be the blending of a firm conception of useful precedent and the progressive tendencies of an able mind. For, let a man be as able and original as he may, he cannot afford to discard knowledge of what has gone before or what is now going on in his own trade and profession. If the printers of today do not wish to be esteemed arrogant when they term this calling of theirs an art, they must be willing, and show that they are willing, to subject it to such laws as have made its sister arts so free. All those concerned in what are accepted as the fine arts, the learned sciences, and professions surround themselves with the history, literature, and concrete examples of the work with which they are particularly engaged. Yet it is only in rare instances that such an atmosphere, with its material appurtenances, is to be found in a printing office. Art does not flourish in hidden places, nor under restraint, nor in ignorance of what talent and genius have accomplished and are accomplishing throughout the world. For to follow precedent wisely does not mean to imitate slavishly one great exemplar, but to study all masters faithfully, letting their great achievements sink slowly into the mind in order that we may patiently derive from the richness of our acquired knowledge and organized system an attitude of our own. The sprightly minded young man, who with his first business breath projects the new and startling

abcdefghijklmnopqrstuvwxyz

ABCDEFGHIJKLMNQRSTUWXYZ

\$1234567890

8 Point No. 141J, 6 Set

### MONOTYPE FACES

The best kind of originality is that which comes after a sound apprenticeship; that which shall prove to be the blending of a firm conception of all useful precedent and the progressive tendencies of an able mind. For, let a man be as able and original as he may, he cannot afford to discard knowledge of what has gone before or what is now going on in his own trade and profession. If the printers of today do not wish to be esteemed arrogant when they term this calling of theirs an art, they must be willing, and show that they are willing, to subject it to such laws as have made its sister arts so free. All those concerned in what are accepted as the fine arts, the learned sciences, and professions surround themselves with the history, literature, and concrete examples of the work with which they are particularly engaged. Yet it is only in rare instances that such an atmosphere, with its material appurtenances, is to be found in a printing office. Art does not flourish in hidden places, nor under restraint, nor in ignorance of what talent and genius have accomplished and are now accomplishing throughout the world. For to follow precedent wisely does not mean to imitate slavishly one great exemplar, but to study all masters faithfully, letting their great achievements sink slowly into the mind in order that we may patiently derive from the richness of our acquired knowledge and organized system an attitude of our own. The sprightly minded young man, who with his first business breath projects the new and startling, inevitably becomes tiresome, and is driven to an early disappearance, while the slower, more solidly endowed student will at least spend as much of his time in avoiding mistakes as in evolving brilliant schemes wherewith to dazzle his contemporaries. The best kind of originality is that which comes after a sound apprenticeship; that which shall prove to be the blending of a firm con-

abcdefghijklmnopqrstuvwxyz

ABCDEFGHIJKLMNQRSTUWXYZ

\$1234567890

12 Point No. 141J, 8 Set

### MONOTYPE FACES

The best kind of originality is that which comes after a sound apprenticeship; that which shall prove itself to be the blending of a firm conception of useful precedent and the progressive tendencies of an able mind. For, let a man be as able and original as he may, he cannot afford to discard knowledge of what has gone before or what is now going on in his own trade and profession. If the printers of today do not wish to be esteemed arrogant when they term this calling of theirs an art, they must be willing, and show that they are willing, to subject it to such laws as have made its sister arts so free. All those concerned in what are accepted as the fine arts, the learned sciences, and professions surround themselves with the history, the literature, and concrete examples of the work with which they are particularly engaged. Yet it is only in rare instances that such an atmosphere, with its material appurtenances, is to be found in a printing office. Art does not flourish in hidden places, nor under restraint, nor in ignorance of what talent and genius have accomplished and

abcdefghijklmnopqrstuvwxyz

ABCDEFGHIJKLMNQRSTUWXYZ

\$1234567890

14 Point No. 141

**COST OF LEADS AND LEADING BY HAND**

Wholly Overcome with the Monotype. You can Cast any Face on a Larger Body to Fit the Space  
**\$1234567890**

18 Point No. 141

**THE ONLY MACHINE TO CONSIDER**

For any Kind of Matter to be kept Standing and Corrected for Later Editions  
**\$1234567890**

24 Point No. 141

**ALTERATIONS EASILY MADE**

As with Foundry Type, and the Investment is Less by 80 per cent.  
**\$1234567890**

30 Point No. 141

**MONOTYPE CORRECTIONS**

Never Stop the Production from Keyboard or Caster  
**\$1234567890**

36 Point No. 141

**FURNISHES FACILITIES**

For all Kinds of Plain and Intricate Work  
**\$1234567890**

36H4 Point No. 141

**SUPPLY A FACE TO FIT THE SPACE**  
**\$1234567890**



18 Point No. 285

**AN INLINE SERIES**

**Is Especially Good for Newspaper Ad  
Composition and Job Work**

**\$1234567890**

24 Point No. 285

**MAGAZINE HEADINGS**

**Composed in Inline Faces Har-  
monize with Text Matter**

**\$1234567890**

30 Point No. 285

**COVER PAGES**

**Displayed in this New Series  
are Very Distinctive**

**\$1234567890**

24 Point No. 286

**YOUR COMPOSITION COST**  
**The Monotype Reduces the Cost of Both**  
**Machine and Hand Composition**  
**\$1234567890**

30 Point No. 286

**CAN BE REDUCED**  
**The Monotype Does This Through**  
**Its Non-Distribution System**  
**\$1234567890**

36 Point No. 286

**START NOW**  
**Eliminating All Distribution**  
**\$1234567890**

# No. 287J. Job Arrangement C2

## Composition Matrices

6 Point No. 287J, 8½ Set

### MONOTYPE FACES

The best kind of originality is that which comes after a thorough apprenticeship; that which shall prove to be the blending of a firm conception of all useful precedent and the progressive tendencies of an able mind. For, let a man be as able and original as he may, he cannot afford to discard knowledge of what has gone before or what is now going on in his own trade or his profession. If the printers of today do not wish to be esteemed arrogant when they term this calling of theirs an art, they must be willing, and show that they are willing, to subject it to such laws as have made its sister arts so free. All those concerned in what are accepted as the fine arts, the learned sciences, and professions surround themselves with the history, the literature, and the concrete examples of the work with which they are particularly engaged. Yet it is only in very rare instances that such an atmosphere, with its material appurtenances, is to be found in a printing office. Art does not flourish in hidden places, nor under restraint, nor in ignorance of what talent and genius have accomplished and are accomplishing throughout the world. For to follow precedent wisely does not mean to imitate slavishly one great exemplar, but to study all masters faithfully, letting their great achievements sink slowly into the mind in order that we may patiently derive from the richness of our acquired knowledge and organized system an attitude of our own. The sprightly minded young man, who with his first business breath projects the

abcdefghijklmnopqrstuvwxy  
ABCDEFGHIJKLMNQPQRSTUVWXYZ  
\$1234567890

8 Point No. 287J, 10½ Set

### MONOTYPE FACES

The best kind of originality is that which comes after a sound apprenticeship; that which shall prove to be the blending of a firm conception of all useful precedent and the progressive tendencies of an able mind. For, let any man be as able and original as he may, he cannot afford to discard knowledge of what has gone before or what is now going on in his own trade and profession. If the printers of today do not wish to be esteemed too arrogant when they term this calling of theirs an art, they must be willing, and show that they are willing, to subject it to just such laws as have made its sister arts so free. All those concerned in what are accepted as the fine arts, the learned sciences, and professions surround themselves with the history, literature, and concrete examples of the work with which they are particularly engaged. Yet it is only in very rare instances that such an atmosphere, with its material appurtenances, is to be found

abcdefghijklmnopqrstuvwxy  
ABCDEFGHIJKLMNQPQRSTUVWXYZ  
\$1234567890

10 Point No. 287J, 12½ Set

### MONOTYPE FACES

The best kind of originality is that which comes after a sound apprenticeship; that which shall prove to be the blending of a firm conception of all useful precedent and the progressive tendencies of an able mind. For, let a man be as able and original as he may, he cannot afford to discard knowledge of what has gone before or what is now going on in his own trade and profession. If the printers of today do not wish to be esteemed arrogant when they term this calling of theirs an art, they must be willing and show that they are willing, to subject it to such laws as have made its sister arts so free. All those

abcdefghijklmnopqrstuvwxy  
ABCDEFGHIJKLMNQPQRSTUVWXYZ  
\$1234567890

### MONOTYPE FACES

The best kind of originality is that which comes after a sound apprenticeship; that which shall prove to be the blending of a firm conception of all useful precedent and the progressive tendencies of an able mind. For, let a man be as able and original as he may, he cannot afford to discard knowledge of what has gone before or what is now going on in his own trade and profession. If the printers of today do not wish to be esteemed arrogant when they term this calling of theirs an art, they must be willing and show that they are willing, to subject it to such laws as have made its sister arts so free. All those concerned in what are accepted as the fine arts, the learned sciences, and professions, surround them-

No. 287

Electro Display Matrices

\*12 Point No. 287

**MONOTYPE TYPE**

**Being Sharp and Clear, Makes for Good Press Work and  
Good Transfers for Offset Printing  
\$1234567890**

14 Point No. 287

**BOOKLETS, FOLDERS**

**and all Fine Catalogs are now set in New Type  
Faces and Rule Borders that Harmonize  
\$1234567890**

18 Point No. 287

**MAINTAIN QUALITY**

**and Save your Distribution Expense  
New Type is an Economy  
\$1234567890**

24 Point No. 287

**HIGH-CLASS BOOKS**

**are Produced with the Use of  
New Monotype Type  
\$1234567890**

30 Point No. 287

**NEWSPAPERS**

**Realize Value of Monotype  
\$1234567890**

\*The 12 point size of this series is cast on the T mold, using the 12 point mold blade.

12 Point No. 218

**MONOTYPE SHADED TYPE FACES**

Cast brand new for every job, give the job a sharp, clean-cut appearance that is not obtainable with used shaded face type

**\$1234567890**

14 Point No. 218

**NOT A LUXURY**

Shaded type faces are not a luxury in up-to-date offices where they make their own type on the Monotype

**\$1234567890**

18 Point No. 218

**HANDSOME AND ECONOMICAL**

Type Faces are at the command of every Progressive Printer who uses the Monotype

**\$1234567890**

24 Point No. 218

**NEW MONOTYPE MATERIAL**

Always at every Compositor's Finger Tips

**\$1234567890**

30 Point No. 218

**JUST THE TYPE**

The Printer Wants when he Wants It

**\$1234567890**

36 Point No. 218

**MONOTYPE RULE**

Means New Rule to Printers

**\$1234567890**

# No. 25J. Job Arrangement Cl.

## Composition Matrices

5 Point No. 25J, 6½ Set

### MONOTYPE FACES

The best kind of originality is that which comes after a sound apprenticeship; that which shall prove to be the blending of a firm conception of all useful precedent and the progressive tendencies of an able mind. For, let a man be as able and original as he may, he cannot afford to discard knowledge of what has gone before or what is now going on in his own trade and profession. If the printers of today do not wish to be esteemed arrogant when they term this calling of theirs an art, they must be willing, and show that they are willing, to subject it to such laws as have made its sister arts so free. All those concerned in what are accepted as the fine arts, the learned sciences and professions, surround themselves with the history, literature, and concrete examples of the work with which they are particularly engaged. Yet it is only in rare instances that such an atmosphere, with its material appurtenances, is to be found in a printing office. Art does not flourish in hidden places, nor under restraint, nor in ignorance of what talent and genius have accomplished and are now accomplishing throughout the world. For to follow precedent wisely does not mean to imitate slavishly one great exemplar, but to study all masters faithfully, letting their great achievements sink slowly into the mind in order that we may patiently derive from the richness of our acquired knowledge and organized system an attitude of our own. The sprightly minded young man, who with his first business breath projects the new and startling, inevitably becomes tiresome, and is driven to an early disappearance; while the slower, more solidly endowed student will at least spend as much of his time in avoiding mistakes as in evolving brilliant schemes where-

abcdefghijklmnopqrstuvwxyz  
 ABCDEFGHIJKLMNOPQRSTUVWXYZ

\$1234567890

6 Point No. 25J, 7 Set

### MONOTYPE FACES

The best kind of originality is that which comes after a sound apprenticeship; that which shall prove itself to be the blending of a firm conception of useful precedent and the progressive tendencies of an able mind. For, let a man be as able and original as he may, he cannot afford to discard knowledge of what has gone before or what is now going on in his own trade and profession. If the printers of today do not wish to be esteemed arrogant when they term this calling of theirs an art, they must be willing, and show that they are willing, to subject it to such laws as have made its sister arts so free. All those concerned in what are accepted as the fine arts, the learned sciences and professions, surround themselves with the history, literature, and concrete examples of the work with which they are particularly engaged. Yet it is only in rare instances that such an atmosphere, with its material appurtenances, is to be found in a printing office. Art does not flourish in hidden places, nor under restraint, nor in ignorance of what talent and genius have accomplished and are accomplishing throughout the world. For to follow precedent wisely does not mean to imitate slavishly one great exemplar, but to study all masters faithfully, letting their great achievements sink slowly into the mind in order that we

abcdefghijklmnopqrstuvwxyz  
 ABCDEFGHIJKLMNOPQRSTUVWXYZ

\$1234567890

7 Point No. 25J, 7½ Set

### MONOTYPE FACES

The best kind of originality is that which comes after a sound apprenticeship; that which shall prove to be the blending of a firm conception of all useful precedent and the progressive tendencies of an able mind. For, let a man be as able and original as he may, he cannot afford to discard knowledge of what has gone before or what is now going on in his own trade and profession. If the printers of today do not wish to be esteemed arrogant when they term this calling of theirs an art, they must be willing, and show that they are willing, to subject it to such laws as have made its sister arts so free. All those concerned in what are accepted as the fine arts, the learned sciences and professions, surround themselves with the history, literature, and concrete examples of the work with which they are particularly engaged. Yet it is only in very rare instances that such an atmosphere, with its material appurtenances, is to be found in a printing office. Art does not flourish in hidden places, nor

abcdefghijklmnopqrstuvwxyz  
 ABCDEFGHIJKLMNOPQRSTUVWXYZ

\$1234567890

8 Point No. 25J, 8½ Set

### MONOTYPE FACES

The best kind of originality is that which comes after a sound apprenticeship; that which shall prove to be the blending of a firm conception of all useful precedent and the progressive tendencies of an able mind. For, let a man be as able and original as he may, he cannot afford to discard knowledge of what has gone before or what is now going on in his own trade and profession. If the printers of today do not wish to be esteemed arrogant when they term this calling of theirs an art, they must be willing, and show that they are willing, to subject it to such laws as have made its sister arts so free. All those concerned in what are accepted as the fine arts, the learned sciences and professions, surround themselves with the history, the literature, and concrete examples of the work with which they may be particularly engaged. Yet it is only in rare instances that such an atmosphere, with its material appurtenances, is to be found in a printing office. Art does not flourish in hidden places, nor under restraint, nor in ignorance of what talent and genius have accomplished and are now accomplishing throughout the world. For to follow precedent wisely does not mean to imitate slavishly one great exemplar, but to study all the masters faithfully, letting their great achievements sink slowly into the mind in order that we may patiently derive from the richness of our acquired knowledge and organized system

abcdefghijklmnopqrstuvwxyz  
 ABCDEFGHIJKLMNOPQRSTUVWXYZ

\$1234567890

9 Point No. 25J, 9½ Set

### MONOTYPE FACES

The best kind of originality is that which comes after a sound apprenticeship; that which shall prove to be the blending of a firm conception of all useful precedent and the progressive tendencies of an able mind. For, let a man be as able and original as he may, he cannot afford to discard knowledge of what has gone before or what is now going on in his own trade and profession. If the printers of today do not wish to be esteemed arrogant when they term this calling of theirs an art, they must be willing, and show that they are willing, to subject it to such laws as have made its sister arts so free. All those concerned in what are accepted as the fine arts, the learned sciences and professions, surround themselves with the history, the literature, and concrete examples of the work with which they may be particularly engaged. Yet it is only in rare instances that such an atmosphere, with its material appurtenances, is to be found in the printing office. Art does not flourish in hidden places, nor under restraint, nor in ignorance of what talent and genius have accomplished and are accomplishing through-

abcdefghijklmnopqrstuvwxyz  
 ABCDEFGHIJKLMNOPQRSTUVWXYZ

\$1234567890

# No. 25J. Job Arrangement C1

## Composition Matrices

10 Point No. 25J, 10 Set

### MONOTYPE FACES

The best kind of originality is that which comes after a sound apprenticeship; that which shall prove to be the blending of a firm conception of all useful precedent and the progressive tendencies of an able mind. For, let a man be as able and original as he may, he cannot afford to discard knowledge of what has gone before or what is now going on in his own trade and profession. If the printers of today do not wish to be esteemed arrogant when they term this calling of theirs an art, they must be willing, and show that they are willing, to subject it to such laws as have made its sister arts so free. All those concerned in what are accepted as the fine arts, the learned sciences and professions, surround themselves with the history, literature, and concrete examples of the work with which they are particularly engaged. Yet it is only in rare instances that such an atmosphere, with its

abcdefghijklmnopqrstuvwxy  
ABCDEFGHIJKLMN**OP**QRSTU**VWXY**Z  
\$1234567890

11 Point No. 25J, 11½ Set

### MONOTYPE FACES

The best kind of originality is that which comes after a sound apprenticeship; that which shall prove to be the blending of a firm conception of all useful precedent and the progressive tendencies of an able mind. For, let a man be as able and original as he may, he cannot afford to discard knowledge of what has gone before or what is now going on in his own trade and profession. If the printers of today do not wish to be esteemed arrogant when they term this calling of theirs an art, they must be willing, and show that they are willing, to subject it to such laws as have made its sister arts so free. All those concerned in what are accepted as the fine arts, the learned sciences and professions, surround themselves with the history, liter-

abcdefghijklmnopqrstuvwxy  
ABCDEFGHIJKLMN**OP**QRSTU**VWXY**Z  
\$1234567890

12 Point No. 25J, 12 Set

### MONOTYPE FACES

The best kind of originality is that which comes after a sound apprenticeship; that which shall prove to be the blending of a firm conception of all useful precedent and the progressive tendencies of an able mind. For, let any man be as able and original as he may, he cannot afford to discard knowledge of what has gone before or what is now going on in his own trade and profession. If the printers of today do not wish to be esteemed arrogant when they term this calling of theirs an art, they must be willing, and show that they are willing, to subject it to such laws as have made its sister arts so free. All those concerned in what are accepted as

abcdefghijklmnopqrstuvwxy  
ABCDEFGHIJKLMN**OP**QRSTU**VWXY**Z  
\$1234567890

### MONOTYPE FACES

The best kind of originality is that which comes after a sound apprenticeship; that which shall prove to be the blending of a firm conception of all useful precedent and the progressive tendencies of an able mind. For, let any man be as able and original as he may, he cannot afford to discard knowledge of what has gone before or what is now going on in his own trade and profession. If the printers of today do not wish to be esteemed arrogant when they term this calling of theirs an art, they must be willing, and show that they are willing, to subject it to such laws as have made its sister arts so free. All those concerned in what are accepted as the fine arts, the learned sciences and professions, surround themselves with the

14 Point No. 25

**QUITE ALONE IN THE FIELD**  
**For School and College Text Books, Fine Editions, Catalogues and**  
**all Work Requiring Mechanical Accuracy**  
**\$1234567890**

18 Point No. 25

**PERFECT PRINTING SURFACE**  
**On Every Letter cast on the Monotype Means Minimum**  
**Make-ready on the Press**  
**\$1234567890**

24 Point No. 25

**ACCURATE JUSTIFICATION**  
**And Uniform Alignment; the Hall-marks**  
**of Monotype Product**  
**\$1234567890**

30 Point No. 25

**USEFUL FACES**  
**Borders and Ornaments; New Ones**  
**Added Every Week**  
**\$1234567890**

36 Point No. 25

**IDLE TIME**  
**Converted Into Real Money**  
**\$1234567890**



# No. 25K. Job Arrangement C1

## Composition Matrices

6 Point No. 25K, 7 Set

### MONOTYPE FACES

The best kind of originality is that which comes after a sound apprenticeship; that which shall prove itself to be the blending of a firm conception of useful precedent and the progressive tendencies of an able mind. For, let a man be as able and original as he may, he cannot afford to discard knowledge of what has gone before or what is now going on in his own trade and profession. If the printers of today do not wish to be esteemed arrogant when they term this calling of theirs an art, they must be willing, and show that they are willing, to subject it to such laws as have made its sister arts so free. All those concerned in what are accepted as the fine arts, the learned sciences and professions, surround themselves with the history, literature, and concrete examples of the work with which they are particularly engaged. Yet it is only in rare instances that such an atmosphere, with all its material appurtenances, is to be found in a printing office. Art does not flourish in hidden places, nor under restraint, nor in ignorance of what talent and genius have accomplished and are accomplishing throughout the world. For to follow precedent wisely does not mean to imitate slavishly one great exemplar, but to study all masters faithfully, letting their great achievements sink slowly into the mind in order that we may patiently derive from the richness of our acquired knowledge and organized system an attitude of our own. The sprightly minded young man, who with his first business breath projects the new and startling, inevitably becomes tiresome, and is driven to an early disappearance; while the slower, more solidly endowed student will at least spend as much of his time in avoiding mistakes as in evolving brilliant schemes wherewith to dazzle his contemporaries. The best kind of originality is that which comes after a sound apprenticeship; that which shall prove to be the blending of a firm conception of all useful precedent and the progressive tendencies of an able mind. For, let a man be as able and original as he may, he cannot afford to discard knowledge of what has gone before or what is now going on in his own trade and profession.

abcdefghijklmnopqrstuvwxyz

ABCDEFGHIJKLMNPOQRSTUVWXYZ

\$1234567890

7 Point No. 25K, 7½ Set

### MONOTYPE FACES

The best kind of originality is that which comes after a sound apprenticeship; that which shall prove to be the blending of a firm conception of all useful precedent and the progressive tendencies of an able mind. For, let a man be as able and original as he may, he cannot afford to discard knowledge of what has gone before or what is now going on in his own trade and profession. If the printers of today do not wish to be esteemed arrogant when they term this calling of theirs an art, they must be willing, and show that they are willing, to subject it to such laws as have made its sister arts so free. All those concerned in what are accepted as the fine arts, the learned sciences and professions, surround themselves with the history, the literature, and concrete examples of the work with which they are particularly engaged. Yet it is only in very rare instances that such an atmosphere, with its material appurtenances, is to be found in a printing office. Art does not flourish in hidden places, nor under restraint, nor in ignorance of what talent and genius have accomplished and are accomplishing throughout the world. For to follow precedent wisely does not mean to imitate slavishly one great exemplar, but to study all masters faithfully, letting their great achievements sink slowly into the mind in order that we may patiently derive from the richness of our acquired knowledge and organized system an attitude of our own. The sprightly minded young man, who with his first business breath projects the new and startling, inevitably becomes tiresome, and is driven to an early disappearance; while the slower, more solidly endowed student will at least spend as much of his time in avoiding

abcdefghijklmnopqrstuvwxyz

ABCDEFGHIJKLMNPOQRSTUVWXYZ

\$1234567890

8 Point No. 25K, 8½ Set

### MONOTYPE FACES

The best kind of originality is that which comes after a sound apprenticeship; that which shall prove to be the blending of a firm conception of all useful precedent and the progressive tendencies of an able mind. For, let a man be as able and original as he may, he cannot afford to discard knowledge of what has gone before or what is now going on in his own trade and profession. If the printers of today do not wish to be esteemed arrogant when they term this calling of theirs an art, they must be willing, and show that they are willing, to subject it to such laws as have made its sister arts so free. All those concerned in what are accepted as the fine arts, the learned sciences and professions, surround themselves with the history, the literature, and concrete examples of the work with which they are particularly engaged. Yet it is only in rare instances that such an atmosphere, with all its material appurtenances, is to be found in a printing office. Art does not flourish in hidden places, nor under restraint, nor in ignorance of what talent and genius have accomplished and are now accomplishing throughout the world. For to follow precedent wisely does not mean to imitate slavishly one great exemplar, but to study all the masters faithfully, letting their great achievements sink slowly into the mind in order that we may patiently derive from the richness of our acquired knowledge and organized system an attitude of our own. The sprightly minded young man, who with his first business breath projects the new and startling, inevitably becomes tiresome, and is driven to an

abcdefghijklmnopqrstuvwxyz

ABCDEFGHIJKLMNPOQRSTUVWXYZ

\$1234567890

9 Point No. 25K, 9 Set

### MONOTYPE FACES

The best kind of originality is that which comes after a sound apprenticeship; that which shall prove to be the blending of a firm conception of all useful precedent and the progressive tendencies of an able mind. For, let a man be as able and original as he may, he cannot afford to discard knowledge of what has gone before or what is now going on in his own trade and profession. If the printers of today do not wish to be esteemed arrogant when they term this calling of theirs an art, they must be willing, and show that they are willing, to subject it to such laws as have made its sister arts so free. All those concerned in what are accepted as the fine arts, the learned sciences and professions, surround themselves with the history, the literature, and concrete examples of the work with which they may be particularly engaged. Yet it is only in rare instances that such an atmosphere, with all its material appurtenances, is to be found in the printing office. Art does not flourish in hidden places, nor under restraint, nor in ignorance of what talent and genius have accomplished and are now accomplishing throughout the world. For to follow precedent wisely does not mean to imitate slavishly one great exemplar, but to study all the masters faithfully, letting their great achievements sink slowly into the mind in order that we may patiently

abcdefghijklmnopqrstuvwxyz

ABCDEFGHIJKLMNPOQRSTUVWXYZ

\$1234567890

# No. 25K. Job Arrangement C1

## Composition Matrices

10 Point No. 25K, 10 Set

### MONOTYPE FACES

*The best kind of originality is that which comes after a sound apprenticeship; that which shall prove to be the blending of a firm conception of all useful precedent and the progressive tendencies of an able mind. For, let a man be as able and original as he may, he cannot afford to discard knowledge of what has gone before or what is now going on in his own trade and profession. If the printers of today do not wish to be esteemed arrogant when they term this calling of theirs an art, they must be willing, and show that they are willing, to subject it to such laws as have made its sister arts so free. All those concerned in what are accepted as the fine arts, the learned sciences, and the professions, surround themselves with the history, the literature, and concrete examples of the work with which they are particularly engaged. Yet it is only in rare instances that such an atmas-*

abcdefghijklmnopqrstuvwxy~~z~~

ABCDEFGHIJKLMN~~OP~~QRSTU~~V~~WXY~~Z~~

\$1234567890

11 Point No. 25K, 11 Set

### MONOTYPE FACES

*The very best kind of originality is that which comes after a thorough apprenticeship; that which shall prove to be the blending of a firm conception of all useful precedent and the progressive tendencies of an able mind. For, let a man be as able and original as he may, he cannot afford to discard knowledge of what has gone before or what is now going on in his own trade and profession. If the printers of today do not wish to be esteemed arrogant when they term this calling of theirs an art, they must be willing, and show that they are willing, to subject it to such laws as have made all its sister arts so free. All those concerned in what are accepted as the fine arts, the learned sciences, and the professions, surround themselves with the history, liter-*

abcdefghijklmnopqrstuvwxy~~z~~

ABCDEFGHIJKLMN~~OP~~QRSTU~~V~~WXY~~Z~~

\$1234567890

12 Point No. 25K, 12 Set

### MONOTYPE FACES

*The best kind of originality is that which comes after a sound apprenticeship; that which shall prove to be the blending of a firm conception of all useful precedent and the progressive tendencies of an able mind. For, let any man be as able and original as he may, he cannot afford to discard knowledge of what has gone before or what is now going on in his own trade and profession. If the printers of today do not wish to be esteemed too arrogant when they term this calling of theirs an art, they must be willing, and show that they are willing, to subject it to such laws as have made its sister arts so free. All those concerned in what are*

abcdefghijklmnopqrstuvwxy~~z~~

ABCDEFGHIJKLMN~~OP~~QRSTU~~V~~WXY~~Z~~

\$1234567890

### MONOTYPE FACES

*The best kind of originality is that which comes after a sound apprenticeship; that which shall prove to be the blending of a firm conception of all useful precedent and the progressive tendencies of an able mind. For, let any man be as able and original as he may, he cannot afford to discard knowledge of what has gone before or what is now going on in his own trade and profession. If the printers of today do not wish to be esteemed too arrogant when they term this calling of theirs an art, they must be willing, and show that they are willing, to subject it to such laws as have made its sister arts so free. All those concerned in what are accepted as the fine arts, and the learned sciences and professions surround them-*

14 Point No. 251

**THERE NEED BE NOTHING THE MATTER**  
*With the Printing Business when you get Your Profits Out of  
Quality and not out of Low Selling Prices*  
**\$1234567890**

18 Point No. 251

**COSTS MAY BE REDUCED**  
*And Quality Greatly Raised by One Operation through  
the Use of the Monotype*  
**\$1234567890**

24 Point No. 251

**KEEP UP THE QUALITY**  
*And Your Customers Will Pay an Extra  
Good Profit for Extra Good Work*  
**\$1234567890**

30 Point No. 251

**FOR ECONOMY**  
*And for Superiority the Monotype  
is in a Field by Itself*  
**\$1234567890**

36 Point No. 251

**THE MONOTYPE**  
*Answers the Cost Problem*  
**\$1234567890**

# No. 26J. Job Arrangement C2

## Composition Matrices

5 Point No. 26J, 6 Set

### MONOTYPE FACES

The best kind of originality is that which comes after a sound apprenticeship; that which shall prove to be the blending of a firm conception of all useful precedent and the progressive tendencies of an able mind. For, let a man be as able and original as he may, he cannot afford to discard knowledge of what has gone before or what is now going on in his own trade and profession. If the printers of today do not wish to be esteemed too arrogant when they term this calling of theirs an art, they must be willing; and show that they are willing, to subject it to such laws as have made its sister arts so free. All those concerned in what are accepted as the fine arts, the learned sciences, and the professions surround themselves with the history, the literature, and concrete examples of the work with which they are particularly engaged. Yet it is only in rare instances that such an atmosphere, with its material appurtenances, is to be found in a printing office. Art does not flourish in hidden places, nor under restraint, nor in ignorance of what talent and genius have accomplished and are now accomplishing throughout the world. For to follow precedent wisely does not mean to imitate slavishly one great exemplar, but to study all masters faithfully, letting their great achievements sink slowly into the mind in order that we may patiently derive from the richness of our acquired knowledge and organized system an attitude of our own. The sprightly minded young man, who with his first business breath projects the new and startling, inevitably becomes tiresome, and is driven to an early disappearance; while the slower, more solidly endowed student will at least spend as much of his time in avoiding mistakes as in evolving brilliant schemes wherewith to dazzle his contemporaries. The best kind of originality is that which comes after a sound apprenticeship; that which shall prove to be the blending of a firm conception of all useful precedent and the progressive tendencies of an able mind. For, let a man be as able and original as he may, he cannot afford to discard knowledge of what has gone before or what is now going on in his own trade and profession. If the printers of today do not wish to be esteemed too arrogant when they term this calling of theirs an art, they must be willing, and show that they are willing, to subject it to such laws as have made its sister arts so free. All those concerned in what are accepted as the fine arts, the learned sciences, and the professions surround themselves with the history, the literature, and concrete examples of the work with which they are particularly engaged. Yet it is only in rare instances that such an atmosphere,

abcdefghijklmnopqrstuvwxyz

ABCDEFGHIJKLMN O PQRSTU VWXYZ

\$1234567890

7 Point No. 26J, 8 Set

### MONOTYPE FACES

The best kind of originality is that which comes after a sound apprenticeship; that which shall prove to be the blending of a firm conception of all the useful precedent and the progressive tendencies of an able mind. For, let a man be as able and original as he may, he cannot afford to discard knowledge of what has gone before or what is now going on in his own trade and profession. If the printers of today do not wish to be esteemed too arrogant when they term this calling of theirs an art, they must be willing, and show that they are willing, to subject it to such laws as have made its sister arts so free. All those concerned in what are accepted as the fine arts, the learned sciences, and the professions surround themselves with the history, the literature, and the concrete examples of the work with which they are particularly engaged. Yet it is only in very rare instances that such an atmosphere, with its material appurtenances, is to be found in a printing office. Art does not flourish in the hidden places, nor under restraint, nor in ignorance of what talent and genius have accomplished and are now accomplishing throughout the world. For to follow precedent wisely does not mean to imitate slavishly one great exemplar, but to study all masters faithfully, letting their great achievements sink slowly into the mind in order that we may patiently derive from the richness of our acquired knowledge and organized system an attitude of our own. The sprightly minded young man, who with his first business breath projects the new and startling, inevitably becomes tiresome, and is driven to an early disappearance; while the slower, more solidly endowed

abcdefghijklmnopqrstuvwxyz

ABCDEFGHIJKLMN O PQRSTU VWXYZ

\$1234567890

6 Point No. 26J, 7 Set

### MONOTYPE FACES

The best kind of originality is that which comes after a sound apprenticeship; that which shall prove to be the blending of a firm conception of all useful precedent and the progressive tendencies of an able mind. For, let a man be as able and original as he may, he cannot afford to discard knowledge of what has gone before or what is now going on in his own trade and profession. If the printers of today do not wish to be esteemed arrogant when they term this calling of theirs an art, they must be willing, and show that they are willing, to subject it to such laws as have made its sister arts so free. All those concerned in what are accepted as the fine arts, the learned sciences, and professions surround themselves with the history, the literature, and concrete examples of the work with which they are particularly engaged. Yet it is only in very rare instances that such an atmosphere, with its material appurtenances, is to be found in a printing office. Art does not flourish in hidden places, nor under restraint, nor in ignorance of what talent and genius have accomplished and are accomplishing throughout the world. For to follow all precedent wisely does not mean to imitate too slavishly one great exemplar, but to study all masters faithfully, letting their great achievements sink slowly into the mind in order that we may patiently derive from the richness of our acquired knowledge and organized system an attitude of our own. The sprightly minded young man, who with his first business breath projects the new and startling, inevitably becomes tiresome, and is driven to an early disappearance; while the slower, more solidly endowed student will at least spend as much of his time in avoiding mistakes as in evolving brilliant schemes wherewith to dazzle his contemporaries. The best kind of originality is that which comes after a sound apprenticeship; that which shall prove to

abcdefghijklmnopqrstuvwxyz

ABCDEFGHIJKLMN O PQRSTU VWXYZ

\$1234567890

8 Point No. 26J, 8 1/2 Set

### MONOTYPE FACES

The best kind of originality is that which comes after a thorough apprenticeship; that which shall prove to be the blending of a firm conception of all useful precedent and the progressive tendencies of an able mind. For, let a man be as able and original as he may, he cannot afford to discard knowledge of what has gone before or what is now going on in his own trade and profession. If the printers of today do not wish to be esteemed arrogant when they term this calling of theirs an art, they must be willing, and show that they are willing, to subject it to such laws as have made its sister arts so free. All those concerned in what are accepted as the fine arts, the learned sciences, and professions surround themselves with the history, the literature, and the concrete examples of the work with which they are particularly engaged. Yet it is only in very rare instances that such an atmosphere, with its material appurtenances, is to be found in a printing office. Art does not flourish in hidden places, nor under restraint, nor in ignorance of what talent and genius have accomplished and are accomplishing throughout the world. For to follow precedent wisely does not mean to imitate slavishly one great exemplar, but to study all the masters faithfully, letting their great achievements sink slowly into the mind in order that we may patiently derive from the richness

abcdefghijklmnopqrstuvwxyz

ABCDEFGHIJKLMN O PQRSTU VWXYZ

\$1234567890

# No. 26J. Job Arrangement C2

## Composition Matrices

9 Point No. 26J, 9 Set

### MONOTYPE FACES

The best kind of originality is that which comes after a sound apprenticeship; that which shall prove to be the blending of a firm conception of all useful precedent and of the progressive tendencies of an able mind. For, let a man be as able and original as he may, he cannot afford to discard knowledge of what has gone before or what is now going on in his own trade and profession. If the printers of today do not wish to be esteemed arrogant when they term this calling of theirs an art, they must be willing, and show that they are willing, to subject it to such laws as have made its sister arts so free. All those concerned in what are accepted as the fine arts, the learned sciences, and professions surround themselves with the history, the literature, and concrete examples of the work with which they are particularly engaged. Yet it is only in rare instances that such an atmosphere, with its material appurtenances, is to be found in a printing office. Art does not flourish in hidden places, nor

abcdefghijklmnopqrstuvwxy  
ABCDEFGHIJKLMNOPQRSTUVWXYZ  
\$1234567890

10 Point No. 26J, 10 Set

### MONOTYPE FACES

The best kind of originality is that which comes after a sound apprenticeship; that which shall prove to be the blending of a firm conception of all useful precedent and the progressive tendencies of an able mind. For, let a man be as able and original as he may, he cannot afford to discard knowledge of what has gone before or what is now going on in his own trade and profession. If the printers of today do not wish to be esteemed too arrogant when they term this calling of theirs an art, they must be willing, and show that they are willing, to subject it to such laws as have made its sister arts so free. All those concerned in what are accepted as the fine arts, the learned sciences, and the professions surround themselves with the history, literature, and concrete examples of the work with which they are particularly engaged. Yet

abcdefghijklmnopqrstuvwxy  
ABCDEFGHIJKLMNOPQRSTUVWXYZ  
\$1234567890

12 Point No. 26J, 12 Set

### MONOTYPE FACES

The best kind of originality is that which comes after a sound apprenticeship; that which shall prove to be the blending of a firm conception of all useful precedent and the progressive tendencies of an able mind. For, let a man be as able and original as he may, he cannot well afford to discard knowledge of what has gone before or what is now going on in his own trade and profession. If the printers of today do not wish to be esteemed arrogant when they term this calling of theirs an art, they must be willing, and show that they are willing, to subject it to such laws

abcdefghijklmnopqrstuvwxy  
ABCDEFGHIJKLMNOPQRSTUVWXYZ  
\$1234567890

### MONOTYPE FACES

The best kind of originality is that which comes after a sound apprenticeship; that which shall prove to be the blending of a firm conception of all useful precedent and the progressive tendencies of an able mind. For, let a man be as able and original as he may, he cannot well afford to discard knowledge of what has gone before or what is now going on in his own trade and profession. If the printers of today do not wish to be esteemed arrogant when they term this calling of theirs an art, they must be willing, and show that they are willing, to subject it to such laws as have made its sister arts so free. All those who are concerned in what

# No. 76J. Job Arrangement C1

## Composition Matrices

5 Point No. 76J, 5½ Set

### MONOTYPE FACES

The best kind of originality is that which comes after a sound apprenticeship; that which shall prove to be the blending of a firm conception of all useful precedent and the progressive tendencies of an able mind. For, let a man be as able and original as he may, he cannot afford to discard knowledge of what has gone before or what is now going on in his own trade and profession. If the printers of today do not wish to be esteemed arrogant when they term this calling of theirs an art, they must be willing and show that they are willing, to subject it to such laws as have made its sister arts so free. All those concerned in what are accepted as the fine arts, the learned sciences and professions, surround themselves with the history, literature, and concrete examples of the work with which they are particularly engaged. Yet it is only in rare instances that such an atmosphere, with its material appurtenances, is to be found in a printing office. Art does not flourish in hidden places, nor under restraint, nor in ignorance of what talent and genius have accomplished and are now accomplishing throughout the world. For to follow precedent wisely does not mean to imitate slavishly one great exemplar, but to study all masters faithfully, letting their great achievements sink slowly into the mind in order that we may patiently derive from the richness of our acquired knowledge and organized system an attitude of our own. The sprightly minded young man who with his first business breath projects the new and startling, inevitably becomes tiresome, and is driven to an early disappearance; while the slower, more solidly endowed student will at least spend as much of his time in avoiding mistakes as in evolving brilliant schemes wherewith to dazzle his contemporaries. The very best kind of originality is that which comes after a sound apprenticeship; that which shall prove to be the blending of a firm conception of all useful precedent and the progressive tendencies of an able mind. For, let a man be as able and original as he may, he cannot afford to discard knowledge of what has gone before or what is now going on in his own trade and profession. If the printers of today do not wish to be esteemed arrogant when they term this calling of theirs an art, they must be willing and show that they are willing, to subject it to such laws as have made its sister arts so free. All those concerned in what are accepted as the fine arts, the learned sciences and professions, surround themselves with the history, literature, and concrete examples of the work with which they are particularly engaged. Yet it is only in rare instances that such an atmosphere, with its material appurtenances, is to be found in a printing office. Art does not flourish in hidden places, nor under restraint, nor in ignorance of what talent and genius have accomplished and are now accomplishing throughout the world. For to follow precedent wisely does not mean to imitate slavishly one great exemplar, but to study all masters faithfully, letting their great achievements sink slowly into the mind in order that we may patiently derive from the richness of our acquired knowledge and organized system an attitude of our own. The sprightly minded young man who with his first business breath projects the new and

abcdefghijklmnopqrstuvwxyz  
 ABCDEFGHIJKLMNOPQRSTUVWXYZ  
 §1234567890

7 Point No. 76J, 8 Set

### MONOTYPE FACES

The best kind of originality is that which comes after a sound apprenticeship; that which shall prove itself to be the blending of a firm conception of useful precedent and the progressive tendencies of an able mind. For, let a man be as able and original as he may, he cannot afford to discard knowledge of what has gone before or what is now going on in his own trade and profession. If the printers of today do not wish to be esteemed arrogant when they term this calling of theirs an art, they must be willing, and show that they are willing, to subject it to such laws as have made its sister arts so free. All those concerned in what are accepted as the fine arts, the learned sciences and the profession, surround themselves with the history, the literature, and concrete examples of the work with which they are particularly engaged. Yet it is only in rare instances that such an atmosphere, with its material appurtenances, is to be found in a printing office. Art does not flourish in hidden places, nor under restraint, nor in ignorance of what talent and genius have accomplished and are accomplishing throughout the world. For to follow precedent wisely does not mean to imitate slavishly one great exemplar but to study all the masters faithfully, letting their great achievements sink slowly into the mind in order that we may patiently derive from the richness of our acquired knowledge and organized system an attitude of our own. The very sprightly minded young man, who with his first business breath projects the new and startling, inevitably becomes tiresome, and is driven to an early disappearance; while the

abcdefghijklmnopqrstuvwxyz  
 ABCDEFGHIJKLMNOPQRSTUVWXYZ  
 §1234567890

6 Point No. 76J, 7 Set

### MONOTYPE FACES

The best kind of originality is that which comes after a sound apprenticeship; that which shall prove itself to be the blending of a firm conception of useful precedent and the progressive tendencies of an able mind. For, let a man be as able and original as he may, he cannot afford to discard knowledge of what has gone before or what is now going on in his own trade and profession. If the printers of today do not wish to be esteemed arrogant when they term this calling of theirs an art, they must be willing, and show that they are willing, to subject it to such laws as have made its sister arts so free. All those concerned in what are accepted as the fine arts, the learned sciences and professions, surround themselves with the history, literature, and concrete examples of the work with which they are particularly engaged. Yet it is only in rare instances that such an atmosphere, with its material appurtenances, is to be found in a printing office. Art does not flourish in hidden places, nor under restraint, nor in ignorance of what talent and genius have accomplished and are accomplishing throughout the world. For to follow precedent wisely does not mean to imitate slavishly one great exemplar, but to study all masters faithfully, letting their great achievements sink slowly into the mind in order that we may patiently derive from the richness of our acquired knowledge and organized system an attitude of our own. The sprightly minded young man, who with his first business breath projects the new and startling, inevitably becomes tiresome, and is driven to an early disappearance; while the slower, more solidly endowed student will at least spend as much of his time in avoiding mistakes as in evolving brilliant schemes wherewith to dazzle his contemporaries. The best kind of originality is that which comes after a sound apprenticeship; that which shall prove to be the blending of a firm conception of all useful precedent and the progressive tendencies of an able mind. For, let a man be as able and original as he may, he cannot afford to discard knowledge of what has gone before or what is now going on in his own trade and profession.

abcdefghijklmnopqrstuvwxyz  
 ABCDEFGHIJKLMNOPQRSTUVWXYZ  
 §1234567890

8 Point No. 76J, 8½ Set

### MONOTYPE FACES

The best kind of originality is that which comes after a sound apprenticeship; that which shall prove to be the blending of a firm conception of all useful precedent and the progressive tendencies of an able mind. For, let a man be as able and original as he may, he cannot afford to discard knowledge of what has gone before or what is now going on in his own trade and profession. If the printers of today do not wish to be esteemed arrogant when they term this calling of theirs an art, they must be willing, and show that they are willing, to subject it to such laws that have made its sister arts so free. All those concerned in what are accepted as the fine arts, the learned sciences and professions, surround themselves with the history, the literature, and concrete examples of the work with which they may be particularly engaged. Yet it is only in rare instances that such an atmosphere, with its material appurtenances, is to be found in a printing office. Art does not flourish in hidden places, nor under restraint, nor in ignorance of what talent and genius have accomplished and are now accomplishing throughout the world. For to follow precedent wisely does not mean to imitate slavishly one great exemplar, but to study all the masters faithfully, letting their great achievements sink slowly into the mind in order that we may patiently derive from the

abcdefghijklmnopqrstuvwxyz  
 ABCDEFGHIJKLMNOPQRSTUVWXYZ  
 §1234567890

# No. 76J. Job Arrangement C1

## Composition Matrices

9 Point No. 76J, 9 Set

### MONOTYPE FACES

The best kind of originality is that which comes after a sound apprenticeship; that which shall prove to be the blending of a firm conception of all useful precedent and the progressive tendencies of an able mind. For, let a man be as able and original as he may, he cannot afford to discard knowledge of what has gone before or what is now going on in his own trade and profession. If the printers of today do not wish to be esteemed arrogant when they term this calling of theirs an art, they must be willing, and show that they are willing, to subject it to such laws as have made its sister arts so free. All those concerned in what are accepted as the fine arts, the learned sciences and professions, surround themselves with the history, the literature, and concrete examples of the work with which they may be particularly engaged. Yet it is only in rare instances that such an atmosphere, with all its material appurtenances, is to be found in the printing office. Art does not flourish in hidden places, nor under restraint, nor in ignorance of what talent and genius have accomplished and are now accomplishing throughout the

abcdefghijklmnopqrstuvwxy  
ABCDEFGHIJKLMNPOQRSTUVWXYZ  
\$1234567890

10 Point No. 76J, 10 Set

### MONOTYPE FACES

The best kind of originality is that which comes after a sound apprenticeship; that which shall prove to be the blending of a firm conception of all useful precedent and the progressive tendencies of an able mind. For, let a man be as able and original as he may, he cannot afford to discard knowledge of what has gone before or what is now going on in his own trade and profession. If the printers of today do not wish to be esteemed arrogant when they term this calling of theirs an art, they must be willing, and show that they are willing, to subject it to such laws as have made its sister arts so free. All those concerned in what are accepted as the fine arts, the learned sciences and professions, surround themselves with the history, literature, and concrete examples of the work with which they are particularly engaged. Yet it is only in rare instances that such an atmosphere, with its

abcdefghijklmnopqrstuvwxy  
ABCDEFGHIJKLMNPOQRSTUVWXYZ  
\$1234567890

12 Point No. 76J, 12 Set

### MONOTYPE FACES

The best kind of originality is that which comes after a sound apprenticeship; that which shall prove to be the blending of a firm conception of all useful precedent and the progressive tendencies of an able mind. For, let any man be as able and original as he may, he cannot afford to discard knowledge of what has gone before or what is now going on in his own trade and profession. If the printers of today do not wish to be esteemed arrogant when they term this calling of theirs an art, they must be willing, and show that they are willing, to subject it to such laws as have made its sister arts so free. All

abcdefghijklmnopqrstuvwxy  
ABCDEFGHIJKLMNPOQRSTUVWXYZ  
\$1234567890

### MONOTYPE FACES

The best kind of originality is that which comes after a sound apprenticeship; that which shall prove to be the blending of a firm conception of all useful precedent and the progressive tendencies of an able mind. For, let any man be as able and original as he may, he cannot afford to discard knowledge of what has gone before or what is now going on in his own trade and profession. If the printers of today do not wish to be esteemed arrogant when they term this calling of theirs an art, they must be willing, and show that they are willing, to subject it to such laws as have made its sister arts so free. All those concerned in what are accepted as the fine arts, the learned sciences and the

# No. 45J. Job Arrangement C1

## Composition Matrices

6 Point No. 45J, 7 Set

### MONOTYPE FACES

The best kind of originality is that which comes after a sound apprenticeship; that which shall prove to be the blending of a firm conception of all useful precedent and the progressive tendencies of an able mind. For, let a man be as able and original as he may, he cannot afford to discard knowledge of what has gone before or what is now going on in his own trade and profession. If the printers of today do not wish to be esteemed arrogant when they term this calling of theirs an art, they must be willing, and show that they are willing, to subject it to such laws as have made its sister arts so free. All those concerned in what are now accepted as the fine arts, the learned sciences and professions, surround themselves with the history, literature, and the concrete examples of the work with which they are particularly engaged. Yet it is only in very rare instances that this atmosphere, with its material appurtenances, is to be found in a printing office. Art does not flourish in hidden places, nor under restraint, nor in ignorance of what talent and genius have accomplished and are now accomplishing throughout the world. For to follow all precedent wisely does not mean to imitate too slavishly one great exemplar, but to study all masters faithfully, letting their great achievements sink slowly into the mind in order that we may patiently derive from the richness of our acquired knowledge and organized system an attitude of our own. The sprightly minded young man, who with his first business breath projects the new and startling, inevitably becomes tiresome, and is driven to an early disappearance; while the slower, more solidly endowed student will at least spend as much of his time in avoiding mistakes as in evolving brilliant schemes wherewith to dazzle his contemporaries. The best kind of originality is that which comes after a sound apprenticeship; that which shall prove to be the blending of a firm conception of all useful precedent and the progressive tendencies of an able mind. For, let any man be as able and original as he may, he cannot afford to discard knowledge of what has gone before or what is now going on in

abcdefghijklmnopqrstuvwxyz  
ABCDEFGHIJKLMNOPQRSTUVWXYZ  
\$1234567890

10 Point No. 45J, 10 Set

### MONOTYPE FACES

The best kind of originality is that which comes after a sound apprenticeship; that which shall prove to be the blending of a firm conception of all useful precedent and the progressive tendencies of an able mind. For, let a man be as able and original as he may, he cannot afford to discard knowledge of what has gone before or what is now going on in his own trade and profession. If the printers of today do not wish to be esteemed arrogant when they term this calling of theirs an art, they must be willing, and show that they are willing, to subject it to such laws as have made its sister arts so free. All those concerned in what are accepted as the fine arts, the learned sciences and professions, surround themselves with the history, literature, and the concrete examples of the work with which they are particularly engaged. Yet it is only in rare instances that such an atmosphere, with its material appurtenances, is to be found in a printing office. Art does not flourish in hidden places, nor under restraint, nor in ignorance of what talent and genius have

abcdefghijklmnopqrstuvwxyz  
ABCDEFGHIJKLMNOPQRSTUVWXYZ  
\$1234567890

8 Point No. 45J, 8½ Set

### MONOTYPE FACES

The best kind of originality is that which comes after a sound apprenticeship; that which shall prove to be the blending of a firm conception of all useful precedent and the progressive tendencies of an able mind. For, let a man be as able and original as he may, he cannot afford to discard knowledge of what has gone before or what is now going on in his own trade and profession. If the printers of today do not wish to be esteemed arrogant when they term this calling of theirs an art, they must be willing, and show that they are willing, to subject it to such laws as have made its sister arts so free. All those concerned in what are accepted as the fine arts, the learned sciences and professions, surround themselves with the history, literature, and the concrete examples of the work with which they may be particularly engaged. Yet it is only in rare instances that such an atmosphere, with its material appurtenances, is to be found in a printing office. Art does not flourish in hidden places, nor under restraint, nor in ignorance of what talent and genius have accomplished and are now accomplishing throughout the world. For to follow precedent wisely does not mean to imitate slavishly one great exemplar, but to study all the masters faithfully, letting their greatest achievements sink slowly into the mind in order that we may patiently derive from

abcdefghijklmnopqrstuvwxyz  
ABCDEFGHIJKLMNOPQRSTUVWXYZ  
\$1234567890

12 Point No. 45J, 12 Set

### MONOTYPE FACES

The best kind of originality is that which comes after a sound apprenticeship; that which shall prove to be the blending of a firm conception of all useful precedent and the progressive tendencies of an able mind. For, let any man be as able and original as he may, he cannot afford to discard knowledge of what has gone before or what is now going on in his own trade and profession. If the printers of today do not wish to be esteemed arrogant when they term this calling of theirs an art, they must be willing, and show that they are willing, to subject it to such laws as have made its sister arts so free. All those concerned in what are accepted as the fine arts and the learned sciences and professions, surround themselves with the

abcdefghijklmnopqrstuvwxyz  
ABCDEFGHIJKLMNOPQRSTUVWXYZ  
\$1234567890



14 Point No. 45

**MONOTYPE TYPE IS GOOD TYPE**  
No Foundry Type Made is More Solid or Has a Better Face than Type  
Cast on the Monotype  
\$1234567890

18 Point No. 45

**QUALITY CATALOGUES**  
If Machine Set Must be Monotype Set "There's a  
Reason"  
\$1234567890

24 Point No. 45

**THEORIES DO NOT APPLY**  
To the Monotype, but Conditions, Which It  
Is Always Ready to Fulfil  
\$1234567890

30 Point No. 45

**THE BEST WAY TO**  
Answer the Sorts and Composition  
Problem Is the Monotype Way  
\$1234567890

36 Point No. 45

**AT EVERY POINT**  
The Monotype Is on the Job  
\$1234567890

# No. 56J. Job Arrangement C2

## Composition Matrices

5 Point No. 56J, 6½ Set

### MONOTYPE FACES

The best kind of originality is that which comes after a sound apprenticeship; that which shall prove to be the blending of a firm conception of all useful precedent and the progressive tendencies of an able mind. For, let a man be as able and original as he may, he cannot afford to discard knowledge of what has gone before or what is now going on in his own trade and profession. If the printers of today do not wish to be esteemed arrogant when they term this calling of theirs an art, they must be willing, and show that they are willing, to subject it to such laws as have made its sister arts so free. All those concerned in what are accepted as the fine arts, the learned sciences, and professions surround themselves with the history, literature, and concrete examples of the work with which they are engaged. Yet it is only in rare instances that such an atmosphere, with its material appurtenances, is to be found in a printing office. Art does not flourish in hidden places, nor under restraint, nor in ignorance of what talent and genius have accomplished and are now accomplishing throughout the world. For to follow precedent wisely does not mean to imitate slavishly one great exemplar, but to study all masters faithfully, letting their great achievements sink slowly into the mind in order that we may patiently derive from the richness of our acquired knowledge and organized system an attitude of our own. The sprightly minded young man, who with his first business breath projects the new and startling, inevitably becomes tiresome, and is driven to an early disappearance; while the slower, more solidly endowed student will at least spend as much of his time in avoiding mistakes as in evolving brilliant schemes wherewith to dazzle his contemporaries. The best kind of originality is that which comes after a sound apprenticeship; that which shall prove to be the blending of a firm conception of all useful precedent and the progressive tendencies of an able mind. For, let a man be as able and original as he may, he cannot afford to discard knowledge of what has gone before or what is now going on in his own trade and profession. If the printers of today do not wish to be esteemed arrogant when they term this calling of theirs an art, they must be willing, and show that they are willing, to subject it to such laws as have made its sister arts so free. All those concerned in what are accepted as the fine arts, the learned sciences and the professions

abcdefghijklmnopqrstuvwxyz

ABCDEFGHIJKLMNPOQRSTUVWXYZ

\$1234567890

5½ Point No. 56J, 7 Set

### MONOTYPE FACES

The best kind of originality is that which comes after a sound apprenticeship; that which shall prove to be the blending of a firm conception of all useful precedent and the progressive tendencies of an able mind. For, let a man be as able and original as he may, he cannot afford to discard knowledge of what has gone before or what is now going on in his own trade and profession. If the printers of today do not wish to be esteemed arrogant when they term this calling of theirs an art, they must be willing, and show that they are willing, to subject it to such laws as have made its sister arts so free. All those concerned in what are now accepted as the fine arts, the learned sciences, and professions surround themselves with the history, literature, and the concrete examples of the work with which they are particularly engaged. Yet it is only in very rare instances that this atmosphere, with its material appurtenances, is to be found in a printing office. Art does not flourish in hidden places, nor under restraint, nor in ignorance of what talent and genius have accomplished and are accomplishing throughout the world. For to follow all precedent wisely does not mean to imitate too slavishly one great exemplar, but to study all masters faithfully, letting their great achievements sink slowly into the mind in order that we may patiently derive from the richness of our acquired knowledge and organized system an attitude of our own. The sprightly minded young man, who with his first business breath projects the new and startling, inevitably becomes tiresome, and is driven to an early disappearance; while the slower, more solidly endowed student will at least spend as much of his time in avoiding mistakes as in evolving brilliant schemes wherewith to dazzle his contemporaries. The best kind of originality is that which comes after a sound apprenticeship; that which shall prove to be the blending of a firm conception of all useful precedent and the progressive tendencies of an able mind. For, let any man be as able and as original as he may, he cannot afford to

abcdefghijklmnopqrstuvwxyz

ABCDEFGHIJKLMNPOQRSTUVWXYZ

\$1234567890

6 Point No. 56J, 7½ Set

### MONOTYPE FACES

The best kind of originality is that which comes after a sound apprenticeship; that which shall prove to be the blending of a firm conception of all useful precedent and the progressive tendencies of an able mind. For, let a man be as able and original as he may, he cannot afford to discard knowledge of what has gone before or what is now going on in his own trade and profession. If the printers of today do not wish to be esteemed arrogant when they term this calling of theirs an art, they must be willing, and show that they are willing, to subject it to such laws as have made its sister arts so free. All those concerned in what are accepted as the fine arts, the learned sciences, and professions surround themselves with the history, the literature, and concrete examples of the work with which they are particularly engaged. Yet it is only in rare instances that such an atmosphere, with its material appurtenances, is to be found in a printing office. Art does not flourish in hidden places, nor under restraint, nor in ignorance of what talent and genius have accomplished and are accomplishing throughout the world. For to follow precedent wisely does not mean to imitate slavishly one great exemplar, but to study all masters faithfully, letting their great achievements sink slowly into the mind in order that we may patiently derive from the richness of our acquired knowledge and organized system an attitude of our own. The sprightly minded young man, who with his first business breath projects the new and startling, inevitably becomes tiresome, and is driven to an early disappearance; while the slower, more solidly endowed student will at least spend as much of his time in avoiding mistakes as in evolving brilliant schemes wherewith to dazzle his contemporaries. The best kind of originality is that which comes after a sound apprenticeship; that which shall prove to be the blending of a firm conception of all useful precedent and the progressive tendencies of an able mind. For, let a man be as able and original as he may, he cannot afford to discard knowledge of what has gone before or what is now going on in his own trade and

abcdefghijklmnopqrstuvwxyz

ABCDEFGHIJKLMNPOQRSTUVWXYZ

\$1234567890

7 Point No. 56J, 7½ Set

### MONOTYPE FACES

The best kind of originality is that which comes after a sound apprenticeship; that which shall prove to be the blending of a firm conception of all useful precedent and the progressive tendencies of an able mind. For, let any man be as able and original as he may, he cannot afford to discard knowledge of what has gone before or what is now going on in his own trade and profession. If the printers of today do not wish to be esteemed arrogant when they term this calling of theirs an art, they must be willing, and show that they are willing, to subject it to such laws as have made its sister arts so free. All those concerned in what are accepted as the fine arts, the learned sciences, and the professions surround themselves with the history, the literature, and concrete examples of the work with which they are particularly engaged. Yet it is only in rare instances that such an atmosphere, with its material appurtenances, is to be found in a printing office. Art does not flourish in hidden places, nor under restraint, nor in ignorance of all that talent and genius have accomplished and are now accomplishing throughout the world. For to follow precedent wisely does not mean to imitate slavishly one great exemplar, but to study all masters faithfully, letting their great achievements sink slowly into the mind in order that we may patiently derive from the richness of our acquired knowledge and organized system an attitude of our own. The sprightly minded young man, who with his first business breath projects the new and startling, inevitably becomes tiresome, and is driven to an early disappearance; while the slower, more solidly endowed student will at least spend as much of his time in avoiding mistakes as in evolving bril-

abcdefghijklmnopqrstuvwxyz

ABCDEFGHIJKLMNPOQRSTUVWXYZ

\$1234567890

# No. 56J. Job Arrangement C2

## Composition Matrices

8 Point No. 56J, 8½ Set

### MONOTYPE FACES

The very best kind of originality is that which comes after a thorough apprenticeship; that which shall prove to be the blending of a firm conception of all useful precedent and the progressive tendencies of an able mind. For, let a man be as able and original as he may, he cannot afford to discard knowledge of what has gone before or what is now going on in his own trade and profession. If the printers of today do not wish to be esteemed arrogant when they term this calling of theirs an art, they must be willing, and show that they are willing, to subject it to such laws as have made its sister arts so free. All those concerned in what are accepted as the fine arts, the learned sciences, and professions surround themselves with the history, the literature, and the concrete examples of the work with which they are particularly engaged. Yet it is only in very rare instances that such an atmosphere, with its material appurtenances, is to be found in a printing office. Art does not flourish in the hidden places, nor under restraint, nor in ignorance of what talent and genius have accomplished and are accomplishing throughout the world. For to follow precedent wisely does not mean to imitate slavishly one great exemplar, but to study all masters faithfully, letting their great

### MONOTYPE FACES

The very best kind of originality is that which comes after a thorough apprenticeship; that which shall prove to be the blending of a firm conception of all useful precedent and the progressive tendencies of an able mind. For, let a man be as able and original as he may, he cannot afford to discard knowledge of what has gone before or what is now going on in his own trade and profession. If the printers of today do not wish to be esteemed arrogant when they term this calling of theirs an art, they must be willing, and show that they are willing, to subject it to such laws as have made its sister arts so free. All those concerned in what are accepted as the fine arts, the learned sciences, and professions surround themselves with the history, the literature, and the concrete examples of the work with which they are particularly engaged. Yet it is only in very rare instances that such an atmosphere, with its material appurtenances, is to be found in a printing office. Art does not flourish in the hidden places, nor under restraint, nor in ignorance of what talent and genius have accomplished and are accomplishing throughout the world. For to follow precedent wisely does not mean to imitate slavishly one great exemplar, but to study all masters faithfully, letting their great achievements sink slowly into the mind in order that we may patiently derive from the richness of all our acquired knowledge and organized system an attitude of our own. The sprightly minded young man, who with his first business breath projects the new and startling, inevitably becomes tiresome, and

abcdefghijklmnopqrstuvwxyz

ABCDEFGHIJKLMNPOQRSTUVWXYZ

\$1234567890

# No. 156J. Job Arrangement C2

## Composition Matrices

5 Point No. 156J, 6½ Set

### MONOTYPE FACES

The best kind of originality is that which comes after a sound apprenticeship; that which shall prove to be the blending of a firm conception of all useful precedent and the progressive tendencies of an able mind. For, let a man be as able and original as he may, he cannot afford to discard knowledge of what has gone before or what is now going on in his own trade and profession. If the printers of today do not wish to be esteemed arrogant when they term this calling of theirs an art, they must be willing, and show that they are willing, to subject it to such laws as have made its sister arts so free. All those concerned in what are accepted as the fine arts, the learned sciences, and professions surround themselves with the history, literature, and concrete examples of the work with which they are engaged. Yet it is only in rare instances that such an atmosphere, with its material appurtenances, is to be found in a printing office. Art does not flourish in hidden places, nor under restraint, nor in ignorance of what talent and genius have accomplished and are now accomplishing throughout the world. For to follow precedent wisely does not mean to imitate slavishly one great exemplar, but to study all masters faithfully, letting their great achievements sink slowly into the mind in order that we may patiently derive from the richness of our acquired knowledge and organized system an attitude of our own. The sprightly minded young man, who with his first business breath projects the new and startling, inevitably becomes tiresome, and is driven to an early disappearance; while the slower, more solidly endowed student will at least spend as much of his time in avoiding mistakes as in evolving brilliant schemes wherewith to dazzle his contemporaries. The best kind of originality is that which comes after a sound apprenticeship; that which shall prove to be the blending of a firm conception of all useful precedent and the progressive tendencies of an able mind. For, let a man be as able and original as he may, he cannot afford to discard knowledge of what has gone before or what is now going on in his

### MONOTYPE FACES

The best kind of originality is that which comes after a sound apprenticeship; that which shall prove to be the blending of a firm conception of all useful precedent and the progressive tendencies of an able mind. For, let a man be as able and original as he may, he cannot afford to discard knowledge of what has gone before or what is now going on in his own trade and profession. If the printers of today do not wish to be esteemed arrogant when they term this calling of theirs an art, they must be willing, and show that they are willing, to subject it to such laws as have made its sister arts so free. All those concerned in what are accepted as the fine arts, the learned sciences, and professions surround themselves with the history, literature, and concrete examples of the work with which they are engaged. Yet it is only in rare instances that such an atmosphere, with its material appurtenances, is to be found in a printing office. Art does not flourish in hidden places, nor under restraint, nor in ignorance of what talent and genius have accomplished and are now accomplishing throughout the world. For to follow precedent wisely does not mean to imitate slavishly one great exemplar, but to study all masters faithfully, letting their great achievements sink slowly into the mind in order that we may patiently derive from the richness of our acquired knowledge and organized system an attitude of our own. The sprightly minded young man, who with his first business breath projects the new and startling, inevitably becomes tiresome, and is driven to an early disappearance; while the slower, more solidly endowed student will at least spend as much of his time in avoiding mistakes as in evolving brilliant schemes wherewith to dazzle his contemporaries. The best kind of originality is that which comes after a sound apprenticeship; that which shall prove to be the blending of a firm conception of all useful precedent and the progressive tendencies of an able mind. For, let a man be as able and original as he may, he cannot afford to discard knowledge of what has gone before or what is now going on in his own trade and profession. If the printers of today do not wish to be esteemed arrogant when they term this calling of theirs an art, they must be willing, and show that they are willing, to subject it to such laws as have made its sister arts so free. All those concerned in what are accepted as the fine arts, the learned sciences, and professions surround themselves with the history, literature, and concrete examples of the work with which they are engaged. Yet it is only in rare instances that such an atmosphere, with its material appurtenances, is to be found in a printing office. Art does not flourish in hidden places, nor under restraint, nor in ignorance of what talent and genius have accomplished and are now accomplishing throughout the world. For to follow precedent wisely does not mean to

abcdefghijklmnopqrstuvwxyz

ABCDEFGHIJKLMNOPQRSTUVWXYZ

81234567890

6 Point No. 156J, 7½ Set

### MONOTYPE FACES

The best kind of originality is that which comes after a sound apprenticeship; that which shall prove to be the blending of a firm conception of all useful precedent and the progressive tendencies of an able mind. For, let a man be as able and original as he may, he cannot afford to discard knowledge of what has gone before or what is now going on in his own trade and profession. If the printers of today do not wish to be esteemed arrogant when they term this calling of theirs an art, they must be willing, and show that they are willing, to subject it to such laws as have made its sister arts so free. All those concerned in what are accepted as the fine arts, the learned sciences, and professions surround themselves with the history, literature, and concrete examples of the work with which they are particularly engaged. Yet it is only in rare instances that such an atmosphere, with its material appurtenances, is to be found in a printing office. Art does not flourish in hidden places, nor under restraint, nor in ignorance of what talent and genius have accomplished and are accomplishing throughout the world. For to follow precedent wisely does not mean to imitate slavishly one great exemplar, but to study all masters faithfully, letting their great achievements sink slowly into the mind in order that we may patiently derive from the richness of our acquired knowledge and organized system an attitude of our own. The sprightly minded young man, who with his first business breath projects the new and startling, inevitably becomes tiresome, and is driven to an early disappearance; while the slower, more solidly endowed student will at least spend as much of his time in avoiding mistakes as in evolving brilliant schemes wherewith to dazzle his contemporaries.

### MONOTYPE FACES

The best kind of originality is that which comes after a sound apprenticeship; that which shall prove to be the blending of a firm conception of all useful precedent and the progressive tendencies of an able mind. For, let a man be as able and original as he may, he cannot afford to discard knowledge of what has gone before or what is now going on in his own trade and profession. If the printers of today do not wish to be esteemed arrogant when they term this calling of theirs an art, they must be willing, and show that they are willing, to subject it to such laws as have made its sister arts so free. All those concerned in what are accepted as the fine arts, the learned sciences, and professions surround themselves with the history, literature, and concrete examples of the work with which they are particularly engaged. Yet it is only in rare instances that such an atmosphere, with its material appurtenances, is to be found in a printing office. Art does not flourish in hidden places, nor under restraint, nor in ignorance of what talent and genius have accomplished and are accomplishing throughout the world. For to follow precedent wisely does not mean to imitate slavishly one great exemplar, but to study all masters faithfully, letting their great achievements sink slowly into the mind in order that we may patiently derive from the richness of our acquired knowledge and organized system an attitude of our own. The sprightly minded young man, who with his first business breath projects the new and startling, inevitably becomes tiresome, and is driven to an early disappearance; while the slower, more solidly endowed student will at least spend as much of his time in avoiding mistakes as in evolving brilliant schemes wherewith to dazzle his contemporaries. The best kind of originality is that which comes after a sound apprenticeship; that which shall prove to be the blending of a firm conception of all useful precedent and the progressive tendencies of an able mind. For, let a man be as able and original as he may, he cannot afford to discard knowledge of what has gone before or what is now going on in his own trade and profession. If the printers of today do not wish to be esteemed arrogant when they term this calling of theirs an art, they must be willing, and show that they are willing, to subject it to such laws as have

abcdefghijklmnopqrstuvwxyz

ABCDEFGHIJKLMNOPQRSTUVWXYZ

81234567890

# No. 256J. Book Arrangement C

## Composition Matrices

6 Point No. 256J, 8 Set

### MONOTYPE FACES

The best kind of originality is that which comes after a sound apprenticeship; that which shall prove to be the blending of a firm conception of all useful precedent and the progressive tendencies of an able mind. For, let a man be as able and original as he may, he cannot afford to discard knowledge of what has gone before or what is now going on in his own trade and profession. If the printers of today do not wish to be esteemed arrogant when they term this calling of theirs an art, they must be willing, and show that they are willing, to subject it to such laws as have made its sister arts so free. All those concerned in what are accepted as the fine arts, the learned sciences, and the professions surround themselves with the history, literature, and the concrete examples of the work with which they are particularly engaged. Yet it is only in rare instances that such an atmosphere, with its material appurtenances, is to be found in a printing office. Art does not flourish in hidden places, nor under restraint, nor in ignorance of what talent and genius have accomplished and are accomplishing throughout the world. For to follow precedent wisely does not mean to imitate slavishly one great exemplar, but to study all masters faithfully, letting their great achievements sink slowly into the mind in order that we may patiently derive from the richness of our acquired knowledge and organized system an attitude of our own. The sprightly minded young man, who with his first business breath projects the new and startling, inevitably becomes tiresome, and is driven to an early disappearance; while the slower, more solidly endowed student will at least spend as much of his time in avoiding mistakes as in evolving brilliant schemes wherewith to

abodefghijklmnopqrstuvwxyz

ABCDEFGHIJKLMNPOQRSTUVWXYZ

81234567890

### MONOTYPE FACES

The best kind of originality is that which comes after a sound apprenticeship; that which shall prove to be the blending of a firm conception of all useful precedent and the progressive tendencies of an able mind. For, let a man be as able and original as he may, he cannot afford to discard knowledge of what has gone before or what is now going on in his own trade and profession. If the printers of today do not wish to be esteemed arrogant when they term this calling of theirs an art, they must be willing, and show that they are willing, to subject it to such laws as have made its sister arts so free. All those concerned in what are accepted as the fine arts, the learned sciences, and the professions surround themselves with the history, literature, and the concrete examples of the work with which they are particularly engaged. Yet it is only in rare instances that such an atmosphere, with its material appurtenances, is to be found in a printing office. Art does not flourish in hidden places, nor under restraint, nor in ignorance of what talent and genius have accomplished and are accomplishing throughout the world. For to follow precedent wisely does not mean to imitate slavishly one great exemplar, but to study all masters faithfully, letting their great achievements sink slowly into the mind in order that we may patiently derive from the richness of our acquired knowledge and organized system an attitude of our own. The sprightly minded young man, who with his first business breath projects the new and startling, inevitably becomes tiresome, and is driven to an early disappearance; while the slower, more solidly endowed student will at least spend as much of his time in avoiding mistakes as in evolving brilliant schemes wherewith to dazzle his contemporaries. The best kind of originality is that which comes after a sound apprenticeship; that which shall prove to be the blending of a firm conception of all useful precedent and the progressive tendencies of an able mind. For, let a man be as able and original as he may, he cannot afford to discard knowledge of what has gone before or what is now going on in his own trade and profession. If the printers of today do not wish to be esteemed arrogant when they term this calling of theirs an art, they must be willing, and show

# No. 233J. Job Arrangement C2

## Composition Matrices

6 Point No. 233J, 7½ Set

### MONOTYPE FACES

The best kind of originality is that which comes after a sound apprenticeship; that which shall prove to be the blending of a firm conception of all useful precedent and the progressive tendencies of an able mind. For, let a man be as able and original as he may, he cannot afford to discard knowledge of what has gone before or what is now going on in his own trade and profession. If the printers of today do not wish to be esteemed arrogant when they term this calling of theirs an art, they must be willing, and show that they are willing, to subject it to such laws as have made its sister arts so free. All those concerned in what are accepted as the fine arts, the learned sciences, and the professions, surround themselves with the history, literature, and the concrete examples of the work with which they are particularly engaged. Yet it is only in rare instances that such an atmosphere, with its material appurtenances, is to be found in a printing office. Art does not flourish in hidden places, nor under restraint, nor in ignorance of what talent and genius have accomplished and are accomplishing throughout the world. For to follow precedent wisely does not mean to imitate slavishly one great exemplar, but to study all masters faithfully, letting their great achievements sink slowly into the mind in order that we may patiently derive from the richness of our acquired knowledge and organized system an attitude of our own. The sprightly minded young man, who with his first business breath projects the new and startling,

abodefghijklmnopqrstuvwxyz

ABCDEFGHIJKLMNPOQRSTUVWXYZ

81234567890

### MONOTYPE FACES

The best kind of originality is that which comes after a sound apprenticeship; that which shall prove to be the blending of a firm conception of all useful precedent and the progressive tendencies of an able mind. For, let a man be as able and original as he may, he cannot afford to discard knowledge of what has gone before or what is now going on in his own trade and profession. If the printers of today do not wish to be esteemed arrogant when they term this calling of theirs an art, they must be willing, and show that they are willing, to subject it to such laws as have made its sister arts so free. All those concerned in what are accepted as the fine arts, the learned sciences, and the professions, surround themselves with the history, literature, and the concrete examples of the work with which they are particularly engaged. Yet it is only in rare instances that such an atmosphere, with its material appurtenances, is to be found in a printing office. Art does not flourish in hidden places, nor under restraint, nor in ignorance of what talent and genius have accomplished and are accomplishing throughout the world. For to follow precedent wisely does not mean to imitate slavishly one great exemplar, but to study all masters faithfully, letting their great achievements sink slowly into the mind in order that we may patiently derive from the richness of our acquired knowledge and organized system an attitude of our own. The sprightly minded young man, who with his first business breath projects the new and startling, inevitably becomes tiresome, and is driven to an early disappearance; while the slower, more solidly endowed student will at least spend as much of his time in avoiding mistakes as in evolving brilliant schemes wherewith to dazzle his contemporaries. The best kind of originality is that which comes after a sound apprenticeship; that which shall prove to be the blending of a firm conception of all useful precedent and the progressive tendencies of an able mind. For, let a man be as able and

# No. 58J. Job Arrangement C1

## Composition Matrices

6 Point No. 58J, 7 Set

### MONOTYPE FACES

The best kind of originality is that which comes after a sound apprenticeship; that which shall prove itself to be the blending of a firm conception of useful precedent and the progressive tendencies of an able mind. For, let a man be as able and original as he may, he cannot afford to discard knowledge of what has gone before or what is now going on in his own trade and profession. If the printers of today do not wish to be esteemed arrogant when they term this calling of theirs an art, they must be willing, and show that they are willing, to subject it to such laws as have made its sister arts so free. All those concerned in what are accepted as the fine arts, the learned sciences, and professions surround themselves with the history, literature, and concrete examples of the work with which they are particularly engaged. Yet it is only in rare instances that such an atmosphere, with its material appurtenances, is to be found in a printing office. Art does not flourish in hidden places, nor under restraint, nor in ignorance of what talent and genius have accomplished and are accomplishing throughout the world. For to follow precedent wisely does not mean to imitate slavishly one great exemplar, but to study all masters faithfully, letting their great achievements sink slowly into the mind in order that we may patiently derive from the richness of our acquired knowledge and organized system an attitude of our own. The sprightly minded young man, who with his first business breath projects the new and startling, inevitably becomes tiresome, and is driven to an early disappearance; while the slower, more solidly endowed student will at least spend as much of his time in avoiding mistakes as in evolving brilliant schemes wherewith to dazzle his contemporaries. The best kind of originality is that which comes after a sound apprenticeship; that which shall prove to be the blending of a firm conception of all useful precedent and the progressive tendencies of an able mind. For, let a man be as able and original as he may, he cannot afford to discard knowledge of what has gone before or what is now going on in his own trade and profession.

abcdefghijklmnopqrstuvwxyz  
 ABCDEFGHIJKLMNOPQRSTUVWXYZ  
 \$1234567890

10 Point No. 58J, 10 Set

### MONOTYPE FACES

The best kind of originality is that which comes after a sound apprenticeship; that which shall prove to be the blending of a firm conception of all useful precedent and the progressive tendencies of an able mind. For, let a man be as able and original as he may, he cannot afford to discard knowledge of what has gone before or what is now going on in his own trade and profession. If the printers of today do not wish to be esteemed arrogant when they term this calling of theirs an art, they must be willing, and show that they are willing, to subject it to such laws as have made its sister arts so free. All those concerned in what are accepted as the fine arts, the learned sciences and professions, surround themselves with the history, literature, and concrete examples of the work with which they are particularly engaged. Yet it is only in rare instances that such an atmosphere, with its material appurtenances, is to be found in the printing office. Art does not flourish in hidden places, nor under restraint, nor in ignorance of

abcdefghijklmnopqrstuvwxyz  
 ABCDEFGHIJKLMNOPQRSTUVWXYZ  
 \$1234567890

8 Point No. 58J, 8½ Set

### MONOTYPE FACES

The best kind of originality is that which comes after a sound apprenticeship; that which shall prove to be the blending of a firm conception of all useful precedent and the progressive tendencies of an able mind. For, let a man be as able and original as he may, he cannot afford to discard knowledge of what has gone before or what is now going on in his own trade and profession. If the printers of today do not wish to be esteemed arrogant when they term this calling of theirs an art, they must be willing, and show that they are willing, to subject it to such laws as have made its sister arts so free. All those concerned in what are accepted as the fine arts, the learned sciences, and professions surround themselves with the history, the literature, and concrete examples of the work, with which they may be particularly engaged. Yet it is only in rare instances that such an atmosphere, with its material appurtenances, is to be found in a printing office. Art does not flourish in hidden places, nor under restraint, nor in ignorance of what talent and genius have accomplished and are now accomplishing throughout the world. For to follow precedent wisely does not mean to imitate slavishly one great exemplar, but to study all the masters faithfully, letting their greatest achievements sink slowly into the mind in order that we may patiently derive from

abcdefghijklmnopqrstuvwxyz  
 ABCDEFGHIJKLMNOPQRSTUVWXYZ  
 \$1234567890

12 Point No. 58J, 12 Set

### MONOTYPE FACES

The best kind of originality is that which comes after a sound apprenticeship; that which shall prove to be the blending of a firm conception of all useful precedent and the progressive tendencies of an able mind. For, let any man be as able and original as he may, he cannot afford to discard knowledge of what has gone before or what is now going on in his own trade and profession. If the printers of today do not wish to be esteemed arrogant when they term this calling of theirs an art, they must be willing, and also show that they are willing, to subject it to such laws as have made its sister arts so free. All those concerned in what are accepted as the fine arts, and the learned sciences and professions surround themselves with

abcdefghijklmnopqrstuvwxyz  
 ABCDEFGHIJKLMNOPQRSTUVWXYZ  
 \$1234567890

No. 58

Electro Display Matrices

14 Point No. 58

**CASTS ALL SPACING MATERIAL**

From the 5-point Thin Space to the 36-point Em Quad and all the Intermediate Point and Set Sizes

\$1234567890

18 Point No. 58

**SETS STRAIGHT MATTER**

Better, Quicker and More Economically than by Any Other Method of Mechanical Composition

\$1234567890

24 Point No. 58

**THE LEADING MAGAZINES**

Are Practically all Composed and Cast on the Monotype Machine

\$1234567890

30 Point No. 58

**MONOTYPE PRODUCT**

Sells for the Same Price as Similar Kinds of Matter Set by Hand

\$1234567890

36 Point No. 58

**LONG RUNS**

Direct from Type show Less Wear

\$1234567890

# No. 258J. Job Arrangement C4

## Composition Matrices

10 Point No. 258J, 8 1/2 Set

### MONOTYPE FACES

The best kind of originality is that which comes after a sound apprenticeship; that which shall prove to be the blending of a firm conception of all useful precedent and the progressive tendencies of an able mind. For, let a man be as able and original as he may, he cannot afford to discard knowledge of what has gone before or what is now going on in his own trade and profession. If the printers of today do not wish to be esteemed arrogant when they term this calling of theirs an art, they must be willing, and show that they are willing, to subject it to such laws as have made its sister arts so free. All those concerned in what are accepted as the fine arts, the learned sciences, and the professions surround themselves with the history, the literature, and concrete examples of the work with which they are particularly engaged. Yet it is only in very rare instances that such an atmosphere, with its material appurtenances, is to be found in a printing office. Art does not flourish in the hidden places, nor under restraint, nor in

abcdefghijklmnopqrstvwxyz  
ABCDEFGHIJKLMNOPQRSTUVWXYZ  
\$1234567890

### MONOTYPE FACES

The best kind of originality is that which comes after a sound apprenticeship; that which shall prove to be the blending of a firm conception of all useful precedent and the progressive tendencies of an able mind. For, let a man be as able and original as he may, he cannot afford to discard knowledge of what has gone before or what is now going on in his own trade and profession. If the printers of today do not wish to be esteemed arrogant when they term this calling of theirs an art, they must be willing, and show that they are willing, to subject it to such laws as have made its sister arts so free. All those concerned in what are accepted as the fine arts, the learned sciences, and the professions surround themselves with the history, the literature, and concrete examples of the work with which they are particularly engaged. Yet it is only in very rare instances that such an atmosphere, with its material appurtenances, is to be found in a printing office. Art does not flourish in the hidden places, nor under restraint, nor in ignorance of what talent and genius have accomplished and are now accomplishing throughout the world. For to follow precedent wisely does not mean to imitate slavishly one

12 Point No. 258J, 10 Set

### MONOTYPE FACES

The best kind of originality is that which comes after a sound apprenticeship; that which shall prove to be the blending of a firm conception of all useful precedent and the progressive tendencies of an able mind. For, let a man be as able and original as he may, he cannot afford to discard knowledge of what has gone before or what is now going on in his own trade and profession. If the printers of today do not wish to be esteemed arrogant when they term this calling of theirs an art, they must be willing, and show that they are willing, to subject it to such laws as have made its sister arts so free. All those concerned in what are accepted as the fine arts, the learned sciences, and the professions, surround themselves with the history, the literature, and concrete examples

abcdefghijklmnopqrstvwxyz  
ABCDEFGHIJKLMNOPQRSTUVWXYZ  
\$1234567890

### MONOTYPE FACES

The best kind of originality is that which comes after a sound apprenticeship; that which shall prove to be the blending of a firm conception of all useful precedent and the progressive tendencies of an able mind. For, let a man be as able and original as he may, he cannot afford to discard knowledge of what has gone before or what is now going on in his own trade and profession. If the printers of today do not wish to be esteemed arrogant when they term this calling of theirs an art, they must be willing, and show that they are willing, to subject it to such laws as have made its sister arts so free. All those concerned in what are accepted as the fine arts, the learned sciences, and the professions, surround themselves with the history, the literature, and concrete examples of the work with which they are particularly engaged. Yet it is only in very rare



14 Point No. 258

**SATISFACTION IN FULL MEASURE**

Means Getting the Best that Money Can Buy. The Monotype Gives that Sort of Satisfaction to Every User of Its Products

\$1234567890

18 Point No. 258

**THE MAXIMUM OF EFFICIENCY**

In a Newspaper or Job Plant is Possible Only with the Monotype and Its Complete Non-Distribution System

\$1234567890

24 Point No. 258

**AVOIDING LOST MOTION**

Is Just as Important in the Hand Department as in the Mechanical Department of a Plant

\$1234567890

30 Point No. 258

**ACTUAL PRODUCTION**

Of Finished Work Ready for the Press Room is the Measure of a Machine

\$1234567890

36 Point No. 258

**WHAT YOU GIVE**

Is Just as Important as What You Get

\$1234567890

# No. 60J. Job Arrangement C2

## Composition Matrices

6 Point No. 60J, 7½ Set

### MONOTYPE FACES

The best kind of originality is that which comes after a sound apprenticeship; that which shall prove to be the blending of a firm conception of all useful precedent and the progressive tendencies of an able mind. For, let a man be as able and original as he may, he cannot afford to discard knowledge of what has gone before or what is now going on in his own trade and profession. If the printers of today do not wish to be esteemed arrogant when they term this calling of theirs an art, they must be willing, and show that they are willing, to subject it to such laws as have made its sister arts so free. All those concerned in what are accepted as the fine arts, the learned sciences, and professions surround themselves with the history, literature, and concrete examples of the work with which they are particularly engaged. Yet it is only in rare instances that such an atmosphere, with its material appurtenances, is to be found in a printing office. Art does not flourish in hidden places, nor under restraint, nor in ignorance of what talent and genius have accomplished and are accomplishing throughout the world. For to follow precedent wisely does not mean to imitate slavishly one great exemplar, but to study all masters faithfully, letting their great achievements sink slowly into the mind in order that we may patiently derive from the richness of our acquired knowledge and organized system an attitude of our own. The sprightly minded young man who with his first business breath projects the new and startling, inevitably becomes tiresome and is driven to an early disappearance; while the slower, more solidly endowed student will at least spend as much of his time in avoiding mistakes as in evolving brilliant schemes wherewith to dazzle his contemporaries.

abcdefghijklmnopqrstuvwxy

ABCDEFGHIJKLMNOPQRSTUVWXYZ

\$1234567890

10 Point No. 60J, 11 Set

### MONOTYPE FACES

The very best kind of originality is that which comes after a sound apprenticeship; that which shall prove itself to be the blending of a firm conception of all useful precedent and the progressive tendencies of an able mind. Let any man be as able and original as he may, he cannot afford to discard knowledge of what has gone before or what is now going on in his own trade and profession. If the printers of today do not wish to be esteemed arrogant when they term this calling of theirs an art, they must be willing, and show that they are willing, to subject it to such laws as have made its sister arts so free. All those concerned in what are accepted as the fine arts, the learned sciences, and professions surround themselves with the history, literature, and concrete examples of the work with which they are particularly engaged. Yet it is only in

abcdefghijklmnopqrstuvwxy

ABCDEFGHIJKLMNOPQRSTUVWXYZ

\$1234567890

8 Point No. 60J, 9 Set

### MONOTYPE FACES

The best kind of originality is that which comes after a sound apprenticeship; that which shall prove to be the blending of a firm conception of all useful precedent and of the progressive tendencies of an able mind. For, let a man be as able and original as he may, he cannot afford to discard knowledge of what has gone before or what is now going on in his own trade and profession. If the printers of today do not wish to be esteemed arrogant when they term this calling of theirs an art, they must be willing, and show that they are willing, to subject it to such laws as have made its sister arts so free. All those concerned in what are accepted as the fine arts, the learned sciences, and professions surround themselves with the history, the literature, and concrete examples of the work with which they are particularly engaged. Yet it is only in rare instances that such an atmosphere, with its material appurtenances, is to be found in a printing office. Art does not flourish in hidden places, nor under restraint, nor in ignorance of what talent and genius have already accomplished and are accomplishing throughout all the world. For to

abcdefghijklmnopqrstuvwxy

ABCDEFGHIJKLMNOPQRSTUVWXYZ

\$1234567890

12 Point No. 60J, 12½ Set

### MONOTYPE FACES

The best kind of originality is that which comes after a sound apprenticeship; that which shall prove to be the blending of a firm conception of all useful precedent and the progressive tendencies of a clever mind. For, let a man be as able and original as he may, he cannot afford to discard a knowledge of what has gone before or what is now going on in his own trade and profession. If the printers of today do not wish to be esteemed arrogant when they term this calling of theirs an art, they must be willing, and show that they are willing, to subject it to such laws as have made its sister arts so free. All those who

abcdefghijklmnopqrstuvwxy

ABCDEFGHIJKLMNOPQRSTUVWXYZ

\$1234567890

14 Point No. 60

**A GREATER PRODUCTION**  
**On a Larger Variety of Profitable Work with Lower Wage**  
**and Overhead Expense**  
**\$1234567890**

18 Point No. 60

**ELIMINATES COMPETITION**  
**On Catalog and Job Work, Variety of Face**  
**and Quality of Work Unexcelled**  
**\$1234567890**

24 Point No. 60

**THE LOGICAL WAY**  
**To Set Railway Tariffs and Time**  
**Tables with Nut Body Figures**  
**\$1234567890**

30 Point No. 60

**STRAIGHT MATTER**  
**Of the Simplest Kind can be**  
**Handled at a Profit**  
**\$1234567890**

36 Point No. 60

**ARTISTIC FACES**  
**For Use on Monotypes**  
**\$1234567890**

# No. 60K. Job Arrangement C2

## Composition Matrices

6 Point No. 60K, 7½ Set

### MONOTYPE FACES

*The best kind of originality is that which comes after a sound apprenticeship; that which shall prove to be the blending of a firm conception of all useful precedent and the progressive tendencies of an able mind. For, let a man be as able and original as he may, he cannot afford to discard knowledge of what has gone before or what is now going on in his own trade and his profession. If the printers of today do not wish to be esteemed too arrogant when they term this calling of theirs an art, they must be willing, and show that they are willing, to subject it to such laws as have made its sister arts so free. All those concerned in what are accepted as the fine arts, the learned sciences, and the professions surround themselves with the history, the literature, and concrete examples of the work with which they are particularly engaged. Yet it is only in rare instances that such an atmosphere, with its material appurtenances, is to be found in a printing office. Art does not flourish in hidden places, nor under restraint, nor in ignorance of what talent and genius have accomplished and are now accomplishing throughout the world. For to follow precedent wisely does not mean to imitate slavishly one great exemplar, but to study all the masters faithfully, letting their great achievements sink slowly into the mind in order that we may patiently derive from the richness of our acquired knowledge and organized system an attitude of our own. The sprightly minded young man who with his first business breath projects the new and the startling ineditably becomes tiresome, and he is driven to an early disappearance; while the slower and more solidly endowed student will at least spend as much of his time in avoiding mistakes as in solving brilliant schemes whereat to gawdle*

abcdefghijklmnopqrstuvwxyz  
ABCDEFGHIJKLMN O PQRSTU VWXYZ  
\$1234567890

10 Point No. 60K, 11 Set

### MONOTYPE FACES

*The very best kind of originality is that which comes after a sound apprenticeship; that which shall prove itself to be the blending of a firm conception of all useful precedent and the progressive tendencies of an able mind. Let any man be as able and original as he may, he cannot afford to discard knowledge of what has gone before or what is now going on in his own trade and profession. If the printers of today do not wish to be esteemed arrogant when they term this calling of theirs an art, they must be willing, and show that they are willing, to subject it to such laws as have made its sister arts so free. All those concerned in what are accepted as the fine arts, the learned sciences, and professions surround themselves with the history, literature, and concrete examples of the work with which they are particularly engaged. Yet it is only in*

abcdefghijklmnopqrstuvwxyz  
ABCDEFGHIJKLMN O PQRSTU VWXYZ  
\$1234567890

8 Point No. 60K, 9 Set

### MONOTYPE FACES

*The best kind of originality is that which comes after a sound apprenticeship; that which shall prove to be the blending of a firm conception of all useful precedent and of the progressive tendencies of an able mind. For, let a man be as able and original as he may, he cannot afford to discard knowledge of what has gone before or what is now going on in his own trade and profession. If the printers of today do not wish to be esteemed arrogant when they term this calling of theirs an art, they must be willing, and show that they are willing, to subject it to such laws as have made its sister arts so free. All those concerned in what are accepted as the fine arts, the learned sciences, and professions surround themselves with the history, the literature and concrete examples of the work with which they are particularly engaged. Yet it is only in rare instances that such an atmosphere, with its material appurtenances, is to be found in a printing office. Art does not flourish in hidden places, nor under restraint, nor in ignorance of what talent and genius have accomplished and are accomplishing throughout the world. For to follow*

abcdefghijklmnopqrstuvwxyz  
ABCDEFGHIJKLMN O PQRSTU VWXYZ  
\$1234567890

12 Point No. 60K, 12½ Set

### MONOTYPE FACES

*The best kind of originality is that which comes after a sound apprenticeship; that which shall prove to be the blending of a firm conception of all useful precedent and the progressive tendencies of a clever mind. For, let any man be as able and original as he may, he cannot afford to discard a knowledge of what has gone before or what is now going on in his own trade and profession. If the printers of today do not wish to be esteemed arrogant when they term this calling of theirs an art, they must be willing, and show that they are willing, to subject it to such laws as have made its sister arts so free. All those who*

abcdefghijklmnopqrstuvwxyz  
ABCDEFGHIJKLMN O PQRSTU VW  
\$1234567890

14 Point No. 601

***JULES VERNE AT HIS BEST***  
***Never Described a More Wonderful Machine Than the***  
***Style DD Monotype Keyboard***  
***\$1234567890***

18 Point No. 601

***WILL COMPOSE TWO MEASURES***  
***As Well as Two Sizes at One Operation. And This***  
***Is but One Point***  
***\$1234567890***

24 Point No. 601

***TWITCH THE SWITCH***  
***To Change Face, Measure, Point Size and***  
***Keep Always on Live Copy***  
***\$1234567890***

30 Point No. 601

***WIDE MEASURES***  
***And Narrow Measures at One***  
***Time Easy for Style DD***  
***\$1234567890***

36 Point No. 601

***ITS LIMIT***  
***Has Never Yet Been Reached***  
***\$1234567890***

18 Point No. 62

**OPERATING EFFICIENCY**  
And High Quality Product Combined with Low  
Cost of Production is the Monotype Way  
**\$1234567890**

24 Point No. 62

**QUALITY CONTROLS**  
The Selling Price and Attracts Buyers  
Who Are Discriminating and  
Know Good Printing  
**\$1234567890**

30 Point No. 62

**NO COMPOSITION**  
Commands a Higher Selling Price  
than Monotype Product  
**\$1234567890**

36 Point No. 62

**MONOTYPE TYPE**  
Endorsed by Type Founders  
**\$1234567890**

# No. 63J. Job Arrangement C2

## Composition Matrices

6 Point No. 63J, 7½ Set

### MONOTYPE FACES

The best kind of originality is that which comes after a sound apprenticeship; that which shall prove to be the blending of a firm conception of all useful precedent and the progressive tendencies of an able mind. For, let a man be as able and original as he may, he cannot afford to discard knowledge of what has gone before or what is now going on in his own trade and his profession. If the printers of today do not wish to be esteemed too arrogant when they term this calling of theirs an art, they must be willing, and show that they are willing, to subject it to such laws as have made its sister arts so free. All those concerned in what are accepted as the fine arts, the learned sciences, and the professions surround themselves with the history, the literature, and concrete examples of the work with which they are particularly engaged. Yet it is only in rare instances that such an atmosphere, with its material appurtenances, is to be found in a printing office. Art does not flourish in hidden places, nor under restraint, nor in ignorance of what talent and genius have accomplished and are now accomplishing throughout the world. For to follow precedent wisely does not mean to imitate slavishly one great exemplar, but to study all the masters faithfully, letting their great achievements sink slowly into the mind in order that we may patiently derive from the richness of our acquired knowledge and organized system an attitude of our own. The sprightly minded young man who with his first business breath projects the new and the startling inevitably becomes tiresome, and he is driven to an early disappearance; while the slower and more solidly endowed student will at least spend as much of his time in avoiding mistakes as in evolving the brilliant schemes wherewith to

abcdefghijklmnopqrstuvwxyz

ABCDEFGHIJKLMNOPQRSTUVWXYZ

\$1234567890

8 Point No. 63J, 9 Set

### MONOTYPE FACES

The best kind of originality is that which comes after a sound apprenticeship; that which shall prove to be the blending of a firm conception of all useful precedent and of the progressive tendencies of an able mind. For, let a man be as able and original as he may, he cannot afford to discard knowledge of what has gone before or what is now going on in his own trade and profession. If the printers of today do not wish to be esteemed arrogant when they term this calling of theirs an art, they must be willing, and show that they are willing, to subject it to such laws as have made its sister arts so free. All those concerned in what are accepted as the fine arts, the learned sciences, and professions surround themselves with the history, the literature and concrete examples of the work with which they are particularly engaged. Yet it is only in rare instances that such an atmosphere, with its material appurtenances, is to be found in a printing office. Art does not flourish in hidden places, nor under restraint, nor in ignorance of what talent and genius have accomplished and are accomplishing throughout the world. For to follow

abcdefghijklmnopqrstuvwxyz

ABCDEFGHIJKLMNOPQRSTUVWXYZ

\$1234567890

10 Point No. 63J, 11 Set

### MONOTYPE FACES

The very best kind of originality is that which comes after a sound apprenticeship; that which shall prove itself to be the blending of a firm conception of all useful precedent and the progressive tendencies of an able mind. For, let a man be as able and as original as he may, he cannot afford to discard all knowledge of what has gone before or what is now going on in his own trade and profession. If the printers of today do not wish to be esteemed arrogant when they term this calling of theirs an art, they must be willing, and show that they are willing, to subject it to such laws as have made its sister arts so free. All those concerned in what are accepted as the fine arts, the learned sciences, and professions surround themselves with the history, the literature, and concrete examples of the work with which they are particularly engaged. Yet it is only in

abcdefghijklmnopqrstuvwxyz

ABCDEFGHIJKLMNOPQRSTUVWXYZ

\$1234567890

12 Point No. 63J, 12½ Set

### MONOTYPE FACES

The best kind of originality is that which comes after a sound apprenticeship; that which shall prove to be the blending of a firm conception of all useful precedent and the progressive tendencies of a clever mind. For, let any man be as able and original as he may, he cannot afford to discard a knowledge of what has gone before or what is now going on in his own trade and profession. If the printers of today do not wish to be esteemed arrogant when they term this calling of theirs an art, they must be willing, and show that they are willing, to subject it to such laws as have made its sister arts so free. All those who

abcdefghijklmnopqrstuvwxyz

ABCDEFGHIJKLMNOPQRSTUVWXYZ

\$1234567890

14 Point No. 63

**ONE SWEETLY SOLEMN THOUGHT**  
Which Comes to the Monotype Owner Is That He Is Prepared  
for Any and Every Job That Comes In  
\$1234567890

18 Point No. 63

**NOTHING IS TOO HARD**  
For the Versatile Monotype, Either in Quality  
or Technical Requirements  
\$1 234567890

24 Point No. 63

**FOR ELECTROTYPING**  
The Matter May Be Run with High  
Spaces and Quads Throughout  
\$1234567890

30 Point No. 63

**FOR LETTERPRESS**  
The Same Ribbon Will Give  
Low Quads and Spaces  
\$1234567890

36 Point No. 63

**FOR DISPLAY**  
Cast Sorts on Monotype  
\$1234567890



# No. 68J. Job Arrangement C1

## Composition Matrices

6 Point No. 68J, 7 Set

### MONOTYPE FACES

The best kind of originality is that which comes after a sound apprenticeship; that which shall prove itself to be the blending of a firm conception of useful precedent and the progressive tendencies of an able mind. For, let a man be as able and original as he may, he cannot afford to discard knowledge of what has gone before or what is now going on in his own trade and profession. If the printers of today do not wish to be esteemed arrogant when they term this calling of theirs an art, they must be willing, and show that they are willing, to subject it to such laws as have made its sister arts so free. All those concerned in what are accepted as the fine arts, the learned sciences, and professions surround themselves with the history, literature, and concrete examples of the work with which they are particularly engaged. Yet it is only in rare instances that such an atmosphere, with its material appurtenances, is to be found in a printing office. Art does not flourish in hidden places, nor under restraint, nor in ignorance of what talent and genius have accomplished and are accomplishing throughout the world. For to follow precedent wisely does not mean to imitate slavishly one great exemplar, but to study all masters faithfully, letting their great achievements sink slowly into the mind in order that we may patiently derive from the richness of our acquired knowledge and organized system an attitude of our own. The sprightly minded young man, who with his first business breath projects the new and startling, inevitably becomes tiresome, and is driven to an early disappearance; while the slower, more solidly endowed student will at least spend as much of his time in avoiding mistakes as in evolving brilliant schemes wherewith to dazzle his contemporaries. The best kind of originality is that which comes after a sound apprenticeship; that which shall prove to be the blending of a firm conception of all useful precedent and the progressive tendencies of an able mind. For, let a man be as able and original as he may, he cannot afford to discard knowledge of what has gone before or what is now going on in his own trade and profession.

abcdefghijklmnopqrstuvwxyz

ABCDEFGHIJKLMNOPQRSTUVWXYZ

\$1234567890

8 Point No. 68J, 8 1/2 Set

### MONOTYPE FACES

The best kind of originality is that which comes after a sound apprenticeship; that which shall prove to be the blending of a firm conception of all useful precedent and the progressive tendencies of an able mind. For, let a man be as able and original as he may, he cannot afford to discard knowledge of what has gone before or what is now going on in his own trade and profession. If the printers of today do not wish to be esteemed arrogant when they term this calling of theirs an art, they must be willing, and show that they are willing, to subject it to such laws as have made its sister arts so free. All those concerned in what are accepted as the fine arts, the learned sciences, and professions surround themselves with the history, the literature, and concrete examples of the work with which they may be particularly engaged. Yet it is only in rare instances that such an atmosphere, with its material appurtenances, is to be found in a printing office. Art does not flourish in hidden places, nor under restraint, nor in ignorance of what talent and genius have accomplished and are now accomplishing throughout the world. For to follow precedent wisely does not mean to imitate slavishly one great exemplar, but to study all the masters faithfully, letting their greatest achievements sink slowly into the mind in order that we may patiently derive from

abcdefghijklmnopqrstuvwxyz

ABCDEFGHIJKLMNOPQRSTUVWXYZ

\$1234567890

10 Point No. 68J, 10 1/2 Set

### MONOTYPE FACES

The best kind of originality is that which comes after a sound apprenticeship; that which shall prove to be the blending of a firm conception of all useful precedent and the progressive tendencies of an able mind. For, let a man be as able and original as he may, he cannot afford to discard knowledge of what has gone before or what is now going on in his own trade and profession. If the printers of today do not wish to be esteemed arrogant when they term this calling of theirs an art, they must be willing, and show that they are willing, to subject it to such laws as have made its sister arts so free. All those concerned in what are accepted as the fine arts, the learned sciences, and professions surround themselves with the history, literature, and concrete examples of the work with which they are particularly engaged. Yet it is only in rare instances that such an atmosphere, with its material appurtenances, is to be found in a printing office. Art does not flourish in hidden places, nor under restraint, nor in ignorance of

abcdefghijklmnopqrstuvwxyz

ABCDEFGHIJKLMNOPQRSTUVWXYZ

\$1234567890

12 Point No. 68J, 12 Set

### MONOTYPE FACES

The best kind of originality is that which comes after a sound apprenticeship; that which shall prove to be the blending of a firm conception of all useful precedent and the progressive tendencies of an able mind. For, let any man be as able and original as he may, he cannot afford to discard knowledge of what has gone before or what is now going on in his own trade and profession. If the printers of today do not wish to be esteemed arrogant when they term this calling of theirs an art, they must be willing, and show that they are willing, to subject it to such laws as have made its sister arts so free. All those concerned in what are accepted as the fine arts, and the learned sciences and professions surround themselves with the

abcdefghijklmnopqrstuvwxyz

ABCDEFGHIJKLMNOPQRSTUVWXYZ

\$1234567890

No. 68

Electro Display Matrices

14 Point No. 68

**TYPE RUN ROUND CUTS AND INITIALS**

Like straight Matter, just as Accurately as with Matter Composed by and  
Run Round by Hand in the Old Way

**\$1234567890**

18 Point No. 68

**ABSOLUTELY NO ADJUSTMENT**

Required on the Monotype Keyboard to Change the Point Size.  
Measure Changed Like Setting a Stick

**\$1234567890**

24 Point No. 68

**EXTRA CHARACTERS**

Easily Inserted in Monotype Matrix Case  
for any Kind of Special Work

**\$1234567890**

30 Point No. 68

**MONOTYPE TYPE**

Is Finished Complete in the Mold.

It is not Shaved or Dressed

**\$1234567890**

36 Point No. 68

**REDUCES COST**

Without Reducing the Price

**\$1234567890**

# No. 68K. Job Arrangement C2

## Composition Matrices

6 Point No. 68K, 7 Set

### MONOTYPE FACES

*The best kind of originality is that which comes after a sound apprenticeship; that which shall prove to be the blending of a firm conception of all useful precedent and the progressive tendencies of an able mind. For, let a man be as able and original as he may, he cannot afford to discard knowledge of what has gone before or what is now going on in his own trade and profession. If the printers of today do not wish to be esteemed arrogant when they term this calling of theirs an art, they must be willing, and show that they are willing, to subject it to such laws as have made its sister arts so free. All those concerned in what are accepted as the fine arts, the learned sciences, and professions surround themselves with the history, the literature, and concrete examples of the work with which they are particularly engaged. Yet it is only in very rare instances that this atmosphere, with its material appurtenances, is to be found in a printing office. Art does not flourish in hidden places, nor under restraint, nor in ignorance of what talent and genius have accomplished and are accomplishing throughout the world. For to follow all precedent wisely does not mean to imitate too slavishly one great exemplar, but to study all masters faithfully, letting their great achievements sink slowly into the mind in order that we may patiently derive from the richness of our acquired knowledge and organized system an attitude of our own. The sprightly minded young man, who with his first business breath projects the new and startling, inevitably becomes tiresome, and is driven to an early disappearance; while the slower, more solidly endowed student will at least spend as much of his time in avoiding mistakes as in evolving brilliant schemes wherewith to dazzle his contemporaries. The best kind of originality is that which comes after a sound apprenticeship; that which shall prove to be the*

abcdefghijklmnopqrstuvwxy

ABCDEFGHIJKLMNOPQRSTUVWXYZ

\$1234567890

10 Point No. 68K, 10 Set

### MONOTYPE FACES

*The best kind of originality is that which comes after a sound apprenticeship; that which shall prove to be the blending of a firm conception of all useful precedent and the progressive tendencies of an able mind. For, let a man be as able and original as he may, he cannot afford to discard knowledge of what has gone before or what is now going on in his own trade and profession. If the printers of today do not wish to be esteemed too arrogant when they term this calling of theirs an art, they must be willing, and show that they are willing, to subject it to such laws as have made its sister arts so free. All those concerned in what are accepted as the fine arts, the learned sciences, and professions surround themselves with the history, literature, and concrete examples of the work with which they are particularly engaged. Yet it is only in rare instances that such an atmosphere, with all its material appurtenances, is to be found in the printing office.*

abcdefghijklmnopqrstuvwxy

ABCDEFGHIJKLMNOPQRSTUVWXYZ

\$1234567890

8 Point No. 68K, 8½ Set

### MONOTYPE FACES

*The best kind of originality is that which comes after a sound apprenticeship; that which shall prove to be the blending of a firm conception of all useful precedent and the progressive tendencies of an able mind. For, let a man be as able and original as he may, he cannot afford to discard knowledge of what has gone before or what is now going on in his own trade and profession. If the printers of today do not wish to be esteemed arrogant when they term this calling of theirs an art, they must be willing, and show that they are willing, to subject it to such laws as have made its sister arts so free. All those concerned in what are accepted as the fine arts, the learned sciences, and professions surround themselves with the history, literature, and concrete examples of the work with which they are particularly engaged. Yet it is only in very rare instances that such an atmosphere, with its material appurtenances, is to be found in a printing office. Art does not flourish in hidden places, nor under restraint, nor in ignorance of what talent and genius have accomplished and are accomplishing throughout the world. For to follow precedent wisely does not mean to imitate slavishly one great exemplar,*

abcdefghijklmnopqrstuvwxy

ABCDEFGHIJKLMNOPQRSTUVWXYZ

\$1234567890

12 Point No. 68K, 12 Set

### MONOTYPE FACES

*The best kind of originality is that which comes after a sound apprenticeship; that which shall prove to be the blending of a firm conception of all useful precedent and the progressive tendencies of an able mind. For, let a man be as able and original as he may, he cannot afford to discard a knowledge of what has gone before or what is now going on in his own trade and profession. If the printers of today do not wish to be esteemed arrogant when they term this calling of theirs an art, they must be willing, and show that they are willing, to subject it to such laws as have made its sister arts so free. All those who are concerned in what*

abcdefghijklmnopqrstuvwxy

ABCDEFGHIJKLMNOPQRSTUVWXYZ

\$1234567890

14 Point No. 681

**THE LAW AND THE PROFITS**  
*Go Hand in Hand if the Composition of Your Legal Work is Done on  
the Versatile and Busy Monotype*  
**\$1234567890**

18 Point No. 681

**SETTING TYPE WITH TWEEZERS**  
*Is Expensive Composition. You Won't Run Out of Sorts or  
Patience the Monotype Way*  
**\$1234567890**

24 Point No. 681

**THE OLD NICK**  
*Caused by "Pulling Type" Won't Bob  
up in Your Pressroom*  
**\$1234567890**

30 Point No. 681

**RUSH WORK**  
*Is Ordinary Work in Monotype  
Composing Rooms*  
**\$1234567890**

36 Point No. 681

**SOMETIME**  
*You Will Buy the Monotype*  
**\$1234567890**

# No. 69J. Job Arrangement C1

## Composition Matrices

6 Point No. 69J, 6 Set

### MONOTYPE FACES

The best kind of originality is that which comes after a sound apprenticeship; that which shall prove to be the blending of a firm conception of all useful precedent and the progressive tendencies of an able mind. For, let a man be as able and original as he may, he cannot afford to discard knowledge of what has gone before or what is now going on in his own trade and profession. If the printers of today do not wish to be esteemed arrogant when they term this calling of theirs an art, they must be willing, and show that they are willing, to subject it to such laws as have made its sister arts so free. All those concerned in what are accepted as the fine arts, the learned sciences, and professions surround themselves with the history, literature, and concrete examples of the work with which they are particularly engaged. Yet it is only in rare instances that such an atmosphere, with its material appurtenances, is to be found in a printing office. Art does not flourish in hidden places, nor under restraint, nor in ignorance of what talent and genius have accomplished and are now accomplishing throughout the world. For to follow precedent wisely does not mean to imitate slavishly one great exemplar, but to study all masters faithfully, letting their great achievements sink slowly into the mind in order that we may patiently derive from the richness of our acquired knowledge and organized system an attitude of our own. The sprightly minded young man, who with his first business breath projects the new and startling, inevitably becomes tiresome, and is driven to an early disappearance; while the slower, more solidly endowed student will at least spend as much of his time in avoiding mistakes as in evolving brilliant schemes wherewith to dazzle his contemporaries. The best kind of originality is that which comes after a sound apprenticeship; that which shall prove to be the blending of a firm conception of all useful precedent and the progressive tendencies of an able mind. For, let a man be as able and original as he may, he cannot afford to discard knowledge of what has gone before or what is now going on in his own trade and profession. If the printers of today do not wish to be esteemed arrogant when they term this calling of theirs an art, they must be willing, and show that they are willing, to subject it to such laws as have made its sister arts so free. All those concerned in what are accepted as the fine arts, the learned sciences, and

abcdefghijklmnopqrstuvwxyz

ABCDEFGHIJKLMNOPQRSTUVWXYZ

\$1234567890

8 Point No. 69J, 7 Set

### MONOTYPE FACES

The best kind of originality is that which comes after a sound apprenticeship; that which shall prove itself to be the blending of a firm conception of useful precedent and the progressive tendencies of an able mind. For, let a man be as able and original as he may, he cannot afford to discard knowledge of what has gone before or what is now going on in his own trade and profession. If the printers of today do not wish to be esteemed arrogant when they term this calling of theirs an art, they must be willing, and show that they are willing, to subject it to such laws as have made its sister arts so free. All those concerned in what are accepted as the fine arts, the learned sciences, and professions surround themselves with the history, literature, and concrete examples of the work with which they are particularly engaged. Yet it is only in rare instances that such an atmosphere, with its material appurtenances, is to be found in a printing office. Art does not flourish in hidden places, nor under restraint, nor in ignorance of what talent and genius have accomplished and are accomplishing throughout the world. For to follow precedent wisely does not mean to imitate slavishly one great exemplar, but to study all masters faithfully, letting their great achievements sink slowly into the mind in order that we may patiently derive from the richness of our acquired knowledge and organized system an attitude of our own. The sprightly minded young man, who with his first business breath projects the new and startling, inevitably becomes tiresome, and is driven to an early disappearance; while the slower, more solidly endowed student will at least spend as

abcdefghijklmnopqrstuvwxyz

ABCDEFGHIJKLMNOPQRSTUVWXYZ

\$1234567890

10 Point No. 69J, 8½ Set

### MONOTYPE FACES

The best kind of originality is that which comes after a sound apprenticeship; that which shall prove to be the blending of a firm conception of all useful precedent and the progressive tendencies of an able mind. For, let a man be as able and original as he may, he cannot afford to discard knowledge of what has gone before or what is now going on in his own trade and profession. If the printers of today do not wish to be esteemed arrogant when they term this calling of theirs an art, they must be willing, and show that they are willing, to subject it to such laws as have made its sister arts so free. All those concerned in what are accepted as the fine arts, the learned sciences, and professions surround themselves with the history, the literature, and concrete examples of the work with which they may be particularly engaged. Yet it is only in rare instances that such an atmosphere, with its material appurtenances, is to be found in a printing office. Art does not flourish in hidden places, nor under restraint nor in ignorance of what talent and genius have accomplished and are now accomplishing throughout the world. For to follow precedent wisely does not mean to imitate slavishly one great exemplar, but to study all masters

abcdefghijklmnopqrstuvwxyz

ABCDEFGHIJKLMNOPQRSTUVWXYZ

\$1234567890

12 Point No. 69J, 10 Set

### MONOTYPE FACES

The best kind of originality is that which comes after a sound apprenticeship; that which shall prove to be the blending of a firm conception of all useful precedent and the progressive tendencies of an able mind. For, let a man be as able and original as he may, he cannot afford to discard knowledge of what has gone before or what is now going on in his own trade and profession. If the printers of today do not wish to be esteemed arrogant when they term this calling of theirs an art, they must be willing, and show that they are willing, to subject it to such laws as have made its sister arts so free. All those concerned in what are accepted as the fine arts, the learned sciences, and professions, surround themselves with the history, literature, and concrete examples of the work with which they are particularly engaged. Yet it is only in

abcdefghijklmnopqrstuvwxyz

ABCDEFGHIJKLMNOPQRSTUVWXYZ

\$1234567890

14 Point No. 69

**ARE YOU FISHING FOR MINNOWS?**

**Don't be Satisfied with the Small Jobs While Your Competitor Walks off with the Large ones, Because he uses Monotype  
\$1234567890**

18 Point No. 69

**BAIT WITH A MONOTYPE**

**If you are not Satisfied with your Present Profits or with the Present Quality of your Printing  
\$1234567890**

24 Point No. 69

**FISH FOR WHALES**

**Get the Big Jobs and the Long Runs You are Now Losing to your Competitor  
\$1234567890**

30 Point No. 69

**THEY WILL BITE**

**At the Quality and the Speed. It Always Pays Well to Be Prompt  
\$1234567890**

36 Point No. 69

**DROP A LINE**

**If You Want Us to Help Catch 'Em  
\$1234567890**

# No. 78J. Job Arrangement C1

## Composition Matrices

6 Point No. 78J, 7½ Set

### MONOTYPE FACES

The best kind of originality is that which comes after a sound apprenticeship; that which shall prove itself to be the blending of a firm conception of useful precedent and the progressive tendencies of an able mind. For, let a man be as able and original as he may, he cannot afford to discard knowledge of what has gone before or what is now going on in his own trade and profession. If the printers of today do not wish to be esteemed arrogant when they term this calling of theirs an art, they must be willing, and show that they are willing, to subject it to such laws as have made its sister arts so free. All those concerned in what are accepted as the fine arts, the learned sciences and the professions, surround themselves with the history, literature, and concrete examples of the work with which they are particularly engaged. Yet it is only in rare instances that such an atmosphere, with its material appurtenances, is to be found in the printing office. Art does not flourish in hidden places, nor under restraint, nor in ignorance of what talent and genius accomplish and are now accomplishing throughout the world. For to follow all precedent wisely does not mean to imitate slavishly one great exemplar, but to study all the masters faithfully, letting their greatest achievements sink slowly into the mind in order that we may patiently derive from the richness of our acquired knowledge and organized system an attitude of our very own. The sprightly minded young man, who with his first business breath projects the new and startling, inevitably becomes tiresome, and is driven to an early disappearance; while the slower, more solidly endowed student will at least spend as much of his time in avoiding mistakes as in evolving brilliant schemes wherewith to dazzle all his contemporaries. The best kind of originality is that which comes after a sound apprenticeship; that which shall prove itself to be the blending of a firm conception of useful precedent and the progressive tendencies of an able mind. For, let any man be as able and original as he may, he cannot afford to discard knowledge of what has gone before or what is now

abcdefghijklmnopqrstuvwxy

ABCDEFGHIJKLMNOPQRSTUVWXYZ

\$1234567890

8 Point No. 78J, 8½ Set

### MONOTYPE FACES

The best kind of originality is that which comes after a sound apprenticeship; that which shall prove to be the blending of a firm conception of all useful precedent and the progressive tendencies of an able mind. For, let a man be as able and original as he may, he cannot afford to discard knowledge of what has gone before or what is now going on in his own trade and profession. If the printers of today do not wish to be esteemed arrogant when they term this calling of theirs an art, they must be willing, and show that they are willing, to subject it to such laws as have made its sister arts so free. All those concerned in what are accepted as the fine arts, the learned sciences and professions, surround themselves with the history, the literature and concrete examples of the work with which they may be particularly engaged. Yet it is only in rare instances that such an atmosphere, with its material appurtenances, is to be found in the printing office. Art does not flourish in hidden places, nor under restraint, nor in ignorance of what talent and genius have accomplished and are still accomplishing throughout the world. For to follow precedent wisely does not mean to imitate slavishly one great exemplar, but to study all the masters faithfully, letting their great achievements sink slowly into the mind in order that we

abcdefghijklmnopqrstuvwxy

ABCDEFGHIJKLMNOPQRSTUVWXYZ

\$1234567890

10 Point No. 78J, 10½ Set

### MONOTYPE FACES

The best kind of originality is that which comes after a sound apprenticeship; that which shall prove to be the blending of a firm conception of all useful precedent and the progressive tendencies of an able mind. For, let a man be as able and original as he may, he cannot afford to discard knowledge of what has gone before or what is now going on in his own trade and profession. If the printers of today do not wish to be esteemed arrogant when they term this calling of theirs an art, they must be willing, and show that they are willing, to subject it to such laws as have made its sister arts so free. All those concerned in what are accepted as the fine arts, the learned sciences, and professions surround themselves with the history, literature, and concrete examples of the work with which they are particularly engaged. Yet it is only in rare instances that such an atmosphere, with its material appurtenances, is to be found in a printing office. Art does not flourish in hidden places, nor under restraint, nor even in ignorance

abcdefghijklmnopqrstuvwxy

ABCDEFGHIJKLMNOPQRSTUVWXYZ

\$1234567890

12 Point No. 78J, 12 Set

### MONOTYPE FACES

The best kind of originality is that which comes after a sound apprenticeship; that which shall prove to be the blending of a firm conception of all useful precedent and the progressive tendencies of an able mind. For, let any man be as able and original as he may, he cannot afford to discard knowledge of what has gone before or what is now going on in his own trade and profession. If the printers of today do not wish to be esteemed arrogant when they term this calling of theirs an art, they must be willing, and show that they are willing, to subject it to such laws as have made its sister arts so free. All those concerned in what are accepted as the fine arts, the learned sciences and the professions, surround themselves with the

abcdefghijklmnopqrstuvwxy

ABCDEFGHIJKLMNOPQRSTUVWXYZ

\$1234567890

14 Point No. 78

**THE MONOTYPE TYPE CASTER**

Is the only one that is Convertible, and can be Quickly changed into a  
Standard Composing Machine

\$1234567890

18 Point No. 78

**AS A COMPOSING MACHINE**

Monotype Product is Identical with the Highest  
Class of Work set by Hand

\$1234567890

24 Point No. 78

**THE LEADING DAILIES**

All Use the Monotype Successfully in  
their Advertising Departments

\$1234567890

30 Point No. 78

**THE LITTLE PRINTER**

Gets into the Big Class with the  
Versatile Monotype

\$1234567890

36 Point No. 78

**750 FONTS**

Now in our Matrix Library

\$1234567890



# No. 78K. Job Arrangement C1

## Composition Matrices

6 Point No. 78K, 7 Set

### MONOTYPE FACES

*The best kind of originality is that which comes after a sound apprenticeship; that which shall prove itself to be the blending of a firm conception of useful precedent and the progressive tendencies of an able mind. For, let a man be as able and original as he may, he cannot afford to discard knowledge of what has gone before or what is now going on in his own trade and profession. If the printers of today do not wish to be esteemed arrogant when they term this calling of theirs an art, they must be willing, and show that they are willing, to subject it to such laws as have made its sister arts so free. All those concerned in what are accepted as the fine arts, the learned sciences, and the professions, surround themselves with the history, literature, and concrete examples of the work with which they are particularly engaged. Yet it is only in rare instances that such an atmosphere, with its material appurtenances, is to be found in the printing office. Art does not flourish in hidden places, nor under restraint, nor in ignorance of what talent and genius accomplish and are now accomplishing throughout the world. For to follow precedent wisely does not mean to imitate slavishly one great exemplar, but to study all the masters faithfully, letting their great achievements sink slowly into the mind in order that we may patiently derive from the richness of our acquired knowledge and organized system an attitude of our very own. The sprightly minded young man, who with his first business breath projects the new and startling, inevitably becomes tiresome, and is driven to an early disappearance; while the slower, more solidly endowed student will at least spend as much of his time in avoiding mistakes as in evolving brilliant schemes wherewith to dazzle all his contemporaries. The best kind of originality is that which comes after a sound apprenticeship; that which shall prove itself to be the blending of a firm conception of useful precedent and the progressive tendencies of an able mind. For, let any man be as able and original as he may, he cannot afford to discard knowledge of what has gone before or what is now*

abcdefghijklmnopqrstuvwxyz

ABCDEFGHIJKLMNPOQRSTUVWXYZ

\$1234567890

10 Point No. 78K, 10½ Set

### MONOTYPE FACES

*The best kind of originality is that which comes after a sound apprenticeship; that which shall prove to be the blending of a firm conception of all useful precedent and the progressive tendencies of an able mind. For, let a man be as able and original as he may, he cannot afford to discard knowledge of what has gone before or what is now going on in his own trade and profession. If the printers of today do not wish to be esteemed arrogant when they term this calling of theirs an art, they must be willing, and show that they are willing, to subject it to such laws as have made its sister arts so free. All those concerned in what are accepted as the fine arts, the learned sciences, and professions surround themselves with the history, literature, and concrete examples of the work with which they are particularly engaged. Yet it is only in rare instances that such an atmosphere, with its material appurtenances, is to be found in a printing office. Art does not flourish in hidden places, nor under restraint, nor even in*

abcdefghijklmnopqrstuvwxyz

ABCDEFGHIJKLMNPOQRSTUVWXYZ

\$1234567890

8 Point No. 78K, 8½ Set

### MONOTYPE FACES

*The best kind of originality is that which comes after a sound apprenticeship; that which shall prove to be the blending of a firm conception of all useful precedent and the progressive tendencies of an able mind. For, let a man be as able and original as he may, he cannot afford to discard knowledge of what has gone before or what is now going on in his own trade and profession. If the printers of today do not wish to be esteemed arrogant when they term this calling of theirs an art, they must be willing, and show that they are willing, to subject it to such laws as have made its sister arts so free. All those concerned in what are accepted as the fine arts, the learned sciences, and professions, surround themselves with the history, the literature and concrete examples of the work with which they may be particularly engaged. Yet it is only in rare instances that such an atmosphere, with its material appurtenances, is to be found in the printing office. Art does not flourish in hidden places, nor under restraint, nor in ignorance of what talent and genius have accomplished and are still accomplishing throughout the world. For to follow precedent wisely does not mean to imitate slavishly one great exemplar, but to study all the masters faithfully, letting their great achievements sink slowly into the mind in order that we*

abcdefghijklmnopqrstuvwxyz

ABCDEFGHIJKLMNPOQRSTUVWXYZ

\$1234567890

12 Point No. 78K, 12 Set

### MONOTYPE FACES

*The best kind of originality is that which comes after a sound apprenticeship; that which shall prove to be the blending of a firm conception of all useful precedent and the progressive tendencies of an able mind. For, let any man be as able and original as he may, he cannot afford to discard knowledge of what has gone before or what is now going on in his own trade and profession. If the printers of today do not wish to be esteemed arrogant when they term this calling of theirs an art, they must be willing, and show that they are willing, to subject it to such laws as have made its sister arts so free. All those concerned in what are accepted as the fine arts, the learned sciences, and the professions, surround themselves with the*

abcdefghijklmnopqrstuvwxyz

ABCDEFGHIJKLMNPOQRSTUVWXYZ

\$1234567890

14 Point No. 781

**THE TYPECASTING PROPOSITION**

*Is an Important Development of the Monotype, and is but One of its  
Many Strong and Desirable Features*

**\$1234567890**

18 Point No. 781

**ASK YOUR PRESSMEN**

*For Their Opinion Regarding the Saving Made  
on Makeready with Monotype Type*

**\$1234567890**

24 Point No. 781

**AGAIN ASK THEM**

*About the Many Advantages of the Low  
Quads and Spaces*

**\$1234567890**

30 Point No. 781

**FOR ELECTROS**

*The Same Mold Delivers High  
or Low Quads & Spaces*

**\$1234567890**

36 Point No. 781

**NO EXTRAS**

*Are Necessary for This*

**\$1234567890**

# No. 81J. Job Arrangement C4

## Composition Matrices

6 Point No. 81J, 7 Set

### MONOTYPE FACES

The best kind of originality is that which comes after a sound apprenticeship; that which shall prove itself to be the blending of a firm conception of useful precedent and the progressive tendencies of an able mind. For, let a man be as able and original as he may, he cannot afford to discard knowledge of what has gone before or what is now going on in his own trade and profession. If the printers of today do not wish to be esteemed arrogant when they term this calling of theirs an art, they must be willing, and show that they are willing, to subject it to such laws as have made its sister arts so free. All those concerned in what are accepted as the fine arts, the learned sciences, and professions surround themselves with the history, literature, and concrete examples of the work with which they are particularly engaged. Yet it is only in rare instances that such an atmosphere, with its material appurtenances, is to be found in a printing office. Art does not flourish in hidden places, nor under restraint, nor in ignorance of what talent and genius have accomplished and are accomplishing throughout the world. For to follow precedent wisely does not mean to imitate slavishly one great exemplar, but to study all masters faithfully, letting their great achievements sink slowly into the mind in order that we may patiently derive from the richness of our acquired knowledge and organized system an attitude of our own. The sprightly minded young man, who with his first business breath projects the new and startling, inevitably becomes tiresome, and is driven to an early disappearance; while the slower, more solidly endowed student will at least spend as much of his time in avoiding mistakes as in evolving brilliant schemes wherewith to dazzle his contemporaries. The best kind of originality is that which comes after a sound apprenticeship; that which shall prove to be the blending of a firm conception of all useful precedent and the progressive tendencies of an able mind. For, let a man be as able and original as he may, he cannot afford to discard knowledge of what has gone before or what is now going on in his own trade and profession.

abcdefghijklmnopqrstuvwxyz  
ABCDEFGHIJKLMNQPQRSTUVWXYZ  
\$1234567890

10 Point No. 81J, 10 Set

### MONOTYPE FACES

The best kind of originality is that which comes after a sound apprenticeship; that which shall prove to be the blending of a firm conception of all useful precedent and the progressive tendencies of an able mind. For, let a man be as able and original as he may, he cannot afford to discard knowledge of what has gone before or what is now going on in his own trade and profession. If the printers of today do not wish to be esteemed arrogant when they term this calling of theirs an art, they must be willing, and show that they are willing, to subject it to such laws as have made its sister arts so free. All those concerned in what are accepted as the fine arts, the learned sciences and professions, surround themselves with the history, literature, and concrete examples of the work with which they are particularly engaged. Yet it is only in rare instances that such an atmosphere, with its material appurtenances, is to be found in the printing office. Art does not flourish in hidden places, nor under restraint, nor in ignorance of

abcdefghijklmnopqrstuvwxyz  
ABCDEFGHIJKLMNQPQRSTUVWXYZ  
\$1234567890

8 Point No. 81J, 8 1/2 Set

### MONOTYPE FACES

The best kind of originality is that which comes after a sound apprenticeship; that which shall prove to be the blending of a firm conception of all useful precedent and the progressive tendencies of an able mind. For, let a man be as able and original as he may, he cannot afford to discard knowledge of what has gone before or what is now going on in his own trade and profession. If the printers of today do not wish to be esteemed arrogant when they term this calling of theirs an art, they must be willing, and show that they are willing, to subject it to such laws as have made its sister arts so free. All those concerned in what are accepted as the fine arts, the learned sciences, and professions surround themselves with the history, the literature, and concrete examples of the work, with which they may be particularly engaged. Yet it is only in rare instances that such an atmosphere, with its material appurtenances, is to be found in a printing office. Art does not flourish in hidden places, nor under restraint, nor in ignorance of what talent and genius have accomplished and are now accomplishing throughout the world. For to follow precedent wisely does not mean to imitate slavishly one great exemplar, but to study all the masters faithfully, letting their greatest achievements sink slowly into the mind in order that we may patiently derive from

abcdefghijklmnopqrstuvwxyz  
ABCDEFGHIJKLMNQPQRSTUVWXYZ  
\$1234567890

12 Point No. 81J, 12 Set

### MONOTYPE FACES

The best kind of originality is that which comes after a sound apprenticeship; that which shall prove to be the blending of a firm conception of all useful precedent and the progressive tendencies of an able mind. For, let any man be as able and original as he may, he cannot afford to discard knowledge of what has gone before or what is now going on in his own trade and profession. If the printers of today do not wish to be esteemed arrogant when they term this calling of theirs an art, they must be willing, and also show that they are willing, to subject it to such laws as have made its sister arts so free. All those concerned in what are accepted as the fine arts, and the learned sciences and professions surround themselves with

abcdefghijklmnopqrstuvwxyz  
ABCDEFGHIJKLMNQPQRSTUVWXYZ  
\$1234567890

18 Point No. 81

**YOUR INVESTMENT IS PROTECTED**

**If you don't Handicap yourself with a Machine that can Never be  
Anything but a Type Caster**

**\$1234567890**

24 Point No. 81

**ASK US TO PROVE OUR CLAIM**

**That the Monotype is the Cheapest, because it is the  
Best Type Caster and Composing Machine**

**\$1234567890**

# No. 92J. Job Arrangement C2

## Composition Matrices

5½ Point No. 92J, 6½ Set

### MONOTYPE FACES

The best kind of originality is that which comes after a sound apprenticeship; that which shall prove to be the blending of a firm conception of all useful precedent and the progressive tendencies of an able mind. For, let a man be as able and original as he may, he cannot afford to discard knowledge of what has gone before or what is now going on in his own trade and profession. If the printers of today do not wish to be esteemed arrogant when they term this calling of theirs an art, they must be willing, and show that they are willing, to subject it to such laws as have made its sister arts so free. All those concerned in what are now accepted as the fine arts, the learned sciences, and professions surround themselves with the history, literature, and the concrete examples of the work with which they are particularly engaged. Yet it is only in very rare instances that this atmosphere, with its material appurtenances, is to be found in a printing office. Art does not flourish in hidden places, nor under restraint, nor in ignorance of what talent and genius have accomplished and are accomplishing throughout the world. For to follow all precedent wisely does not mean to imitate too slavishly one great exemplar, but to study all masters faithfully, letting their great achievements sink slowly into the mind in order that we may patiently derive from the richness of our acquired knowledge and organized system an attitude of our own. The sprightly minded young man, who with his first business breath projects the new and startling, inevitably becomes tiresome, and is driven to an early disappearance; while the slower, more solidly endowed student will at least spend as much time in avoiding mistakes as in evolving brilliant schemes wherewith to dazzle his contemporaries. The best kind of originality is that which comes after a sound apprenticeship; that which shall prove to be the blending of a firm conception of all useful precedent and the progressive tendencies of an able mind. For, let any man be as able and original as he may, he cannot afford to discard knowledge of what has gone before or what is now going on in his own trade and profession. If the printers of today do not wish to be esteemed arrogant when they term this calling of theirs an art, they

abcdefghijklmnopqrstuvwxyz  
 ABCDEFGHIJKLMNOPQRSTUVWXYZ  
 81234567890

7 Point No. 92J, 8 Set

### MONOTYPE FACES

The best kind of originality is that which comes after a sound apprenticeship; that which shall prove to be the blending of a firm conception of all useful precedent and the progressive tendencies of an able mind. For, let a man be as able and original as he may, he cannot afford to discard knowledge of what has gone before or what is now going on in his own trade and profession. If the printers of today do not wish to be esteemed too arrogant when they term this calling of theirs an art, they must be willing, and show that they are willing, to subject it to such laws as have made its sister arts so free. All those concerned in what are accepted as the fine arts, the learned sciences, and the professions surround themselves with the history, the literature, and concrete examples of the work with which they are particularly engaged. Yet it is only in very rare instances that such an atmosphere, with its material appurtenances, is to be found in a printing office. Art does not flourish in the hidden places, nor under restraint, nor in ignorance of what talent and genius have accomplished and are now accomplishing throughout the world. For to follow precedent wisely does not mean to imitate slavishly one great exemplar, but to study all masters faithfully, letting their great achievements sink slowly into the mind in order that we may patiently derive from the richness of our acquired knowledge and organized system an attitude of our own. The sprightly minded young man, who with his first business breath projects the new and startling, inevitably becomes tiresome, and is driven to an early disappearance; while the slower, more solidly endowed

abcdefghijklmnopqrstuvwxyz  
 ABCDEFGHIJKLMNOPQRSTUVWXYZ  
 81234567890

6 Point No. 92J, 7 Set

### MONOTYPE FACES

The best kind of originality is that which comes after a sound apprenticeship; that which shall prove to be the blending of a firm conception of all useful precedent and the progressive tendencies of an able mind. For, let a man be as able and original as he may, he cannot afford to discard knowledge of what has gone before or what is now going on in his own trade and profession. If the printers of today do not wish to be esteemed arrogant when they term this calling of theirs an art, they must be willing, and show that they are willing, to subject it to such laws as have made its sister arts so free. All those concerned in what are accepted as the fine arts, the learned sciences, and professions surround themselves with the history, literature, and concrete examples of the work with which they are particularly engaged. Yet it is only in very rare instances that this atmosphere, with its material appurtenances, is to be found in a printing office. Art does not flourish in hidden places, nor under restraint, nor in ignorance of what talent and genius have accomplished and are accomplishing throughout the world. For to follow precedent wisely does not mean to imitate slavishly one great exemplar, but to study all masters faithfully, letting their great achievements sink slowly into the mind in order that we may patiently derive from the richness of our acquired knowledge and organized system an attitude of our own. The sprightly minded young man, who with his first business breath projects the new and startling, inevitably becomes tiresome, and is driven to an early disappearance; while the slower, more solidly endowed student will at least spend as much of his time in avoiding mistakes as in evolving brilliant schemes wherewith to dazzle his contemporaries. The best kind of originality is that which comes after a sound apprenticeship; that which shall prove to

abcdefghijklmnopqrstuvwxyz  
 ABCDEFGHIJKLMNOPQRSTUVWXYZ  
 81234567890

8 Point No. 92J, 8½ Set

### MONOTYPE FACES

The best kind of originality is that which comes after a sound apprenticeship; that which shall prove to be the blending of a firm conception of all useful precedent and the progressive tendencies of an able mind. For, let a man be as able and original as he may, he cannot afford to discard knowledge of what has gone before or what is now going on in his own trade and profession. If the printers of today do not wish to be esteemed arrogant when they term this calling of theirs an art, they must be willing, and show that they are willing, to subject it to such laws as have made its sister arts so free. All those concerned in what are accepted as the fine arts, the learned sciences, and professions surround themselves with the history, literature, and concrete examples of the work with which they are particularly engaged. Yet it is only in very rare instances that such an atmosphere, with its material appurtenances, is to be found in a printing office. Art does not flourish in hidden places, nor under restraint, nor in ignorance of what talent and genius have accomplished and are accomplishing throughout the world. For to follow precedent wisely does not mean to imitate slavishly one great exemplar, but to study all of the masters faithfully, letting their great achievements sink slowly into the mind in order that we may patiently derive from the rich-

abcdefghijklmnopqrstuvwxyz  
 ABCDEFGHIJKLMNOPQRSTUVWXYZ  
 81234567890

# No. 92J. Job Arrangement C2

## Composition Matrices

10 Point No. 92J, 10½ Set

### MONOTYPE FACES

The best kind of originality is that which comes after a sound apprenticeship; that which shall prove to be the blending of a firm conception of all useful precedent and the progressive tendencies of an able mind. For, let any man be as able and original as he may, he cannot afford to discard knowledge of what has gone before or what is now going on in his own trade and profession. If the printers of today do not wish to be esteemed too arrogant when they term this calling of theirs an art, they must be willing, and show that they are willing, to subject it to such laws as have made its sister arts so very free. All those concerned in what are accepted as the fine arts, the learned sciences, and professions surround themselves with the history, literature, and concrete examples of the work with which they are particularly engaged. Yet it is only in very rare instances that such an atmosphere, with

abcdefghijklmnopqrstuvwxyz  
ABCDEFGHIJKLMN OPQRSTUVWXYZ  
\$1234567890

11 Point No. 92J, 11½ Set

### MONOTYPE FACES

The best kind of originality is that which comes after a sound apprenticeship; that which shall prove to be the blending of a firm conception of all useful precedent and the progressive tendencies of an able mind. For, let a man be as able and original as he may, he cannot afford to discard knowledge of what has gone before or what is now going on in his own trade and profession. If the printers of today do not wish to be esteemed too arrogant when they term this calling of theirs an art, they must be willing, and show they are willing, to subject it to such laws as have made its sister arts so free. All those concerned in what are accepted as the fine arts, the learned sciences, and professions surround themselves with the history, literature, and concrete ex-

abcdefghijklmnopqrstuvwxyz  
ABCDEFGHIJKLMN OPQRSTUVWXYZ  
\$1234567890

12 Point No. 92J, 12 Set

### MONOTYPE FACES

The best kind of originality is that which comes after a sound apprenticeship; that which shall prove to be the blending of a firm conception of all useful precedent and the progressive tendencies of an able mind. For, let a man be as able and original as he may, he cannot afford to discard a knowledge of what has gone before or what is now going on in his own trade and profession. If the printers of today do not wish to be esteemed arrogant when they term this calling of theirs an art, they

abcdefghijklmnopqrstuvwxyz  
ABCDEFGHIJKLMN OPQRSTUVWXYZ  
\$1234567890

### MONOTYPE FACES

The best kind of originality is that which comes after a sound apprenticeship; that which shall prove to be the blending of a firm conception of all useful precedent and the progressive tendencies of an able mind. For, let a man be as able and original as he may, he cannot afford to discard a knowledge of what has gone before or what is now going on in his own trade and profession. If the printers of today do not wish to be esteemed arrogant when they term this calling of theirs an art, they must be willing, and show that they are willing, to subject it to such laws

18 Point No. 94

**THE SOUL OF A TYPECASTER IS THE MOLD**

To Combine Speed and Quality the Mold Must be Easily Adjusted to Take Up Wear and be Properly Cooled to Produce Solid Type

**\$1234567890**

24 Point No. 94

**THE RECIPROCATING MONOTYPE MOLD**

Combines Ease of Adjustment, Water Cooling and All of the Correct Principles of Typecasting

**\$1234567890**

30 Point No. 94

**HIGH SPEED IS MADE POSSIBLE**

With Marvelous Accuracy Through the Mechanical Methods Designed for It Alone

**\$1234567890**

36 Point No. 94

**TYPE THAT IS RIGHT**

Perfect In Both Body and Face Is the Result

**\$1234567890**

# No. 97J. Job Arrangement C2.

## Composition Matrices

6 Point No. 97J, 7 Set

### MONOTYPE FACES

The best kind of originality is that which comes after a sound apprenticeship; that which shall prove to be the blending of a firm conception of all useful precedent and the progressive tendencies of an able mind. For, let a man be as able and original as he may, he cannot afford to discard knowledge of what has gone before or what is now going on in his own trade and profession. If the printers of today do not wish to be esteemed arrogant when they term this calling of theirs an art, they must be willing, and show that they are willing, to subject it to such laws as have made its sister arts so free. All those concerned in what are accepted as the fine arts, the learned sciences, and professions surround themselves with the history, literature, and the concrete examples of the work with which they are particularly engaged. Yet it is only in very rare instances that this atmosphere, with its material appurtenances, is to be found in a printing office. Art does not flourish in hidden places, nor under restraint, nor in ignorance of what talent and genius have accomplished and are accomplishing throughout the world. For to follow precedent wisely does not mean to imitate slavishly one great exemplar, but to study all masters faithfully; letting their great achievements sink slowly into the mind in order that we may patiently derive from the richness of our acquired knowledge and organized system an attitude of our own. The sprightly minded young man, who with his first business breath projects the new and startling, inevitably becomes tiresome, and is driven to an early disappearance; while the slower, more solidly endowed student will at least spend as much of his time in avoiding mistakes as in evolving brilliant schemes wherewith to dazzle his contemporaries. The best kind of originality is that which comes after a sound apprenticeship; that which shall prove to

abcdefghijklmnopqrstuvwxy  
ABCDEFGHIJKLMNOPQRSTUVWXYZ  
#1234567890

10 Point No. 97J, 10 1/2 Set

### MONOTYPE FACES

The best kind of originality is that which comes after a sound apprenticeship; that which shall prove to be the blending of a firm conception of all useful precedent and the progressive tendencies of an able mind. For, let any man be as able and original as he may, he cannot afford to discard knowledge of what has gone before or what is now going on in his own trade and profession. If the printers of today do not wish to be esteemed too arrogant when they term this calling of theirs an art, they must be willing, and show that they are willing, to subject it to such laws as have made its sister arts so free. All those concerned in what are accepted as the fine arts, the learned sciences, and professions surround themselves with the history, literature, and concrete examples of the work with which they are particularly engaged. Yet it is only in very rare instances that such an atmosphere, with

abcdefghijklmnopqrstuvwxy  
ABCDEFGHIJKLMNOPQRSTUVWXYZ  
#1234567890

8 Point No. 97J, 8 1/2 Set

### MONOTYPE FACES

The best kind of originality is that which comes after a sound apprenticeship; that which shall prove to be the blending of a firm conception of all useful precedent and the progressive tendencies of an able mind. For, let a man be as able and original as he may, he cannot afford to discard knowledge of what has gone before or what is now going on in his own trade and profession. If the printers of today do not wish to be esteemed arrogant when they term this calling of theirs an art, they must be willing, and show that they are willing, to subject it to such laws as have made its sister arts so free. All those concerned in what are accepted as the fine arts, the learned sciences, and professions surround themselves with the history, literature, and concrete examples of the work with which they are particularly engaged. Yet it is only in rare instances that such an atmosphere, with its material appurtenances, is to be found in a printing office. Art does not flourish in hidden places, nor under restraint, nor in ignorance of what talent and genius have accomplished and are accomplishing throughout the world. For to follow precedent wisely does not mean to imitate slavishly one great exemplar,

abcdefghijklmnopqrstuvwxy  
ABCDEFGHIJKLMNOPQRSTUVWXYZ  
#1234567890

12 Point No. 97J, 12 Set

### MONOTYPE FACES

The best kind of originality is that which comes after a sound apprenticeship; that which shall prove to be the blending of a firm conception of all useful precedent and the progressive tendencies of an able mind. For, let a man be as able and original as he may, he cannot afford to discard a knowledge of what has gone before or what is now going on in his own trade and profession. If the printers of today do not wish to be esteemed arrogant when they term this calling of theirs an art, they must be willing, and show that they are willing, to subject it to such laws as have made its sister arts so free. All those who are concerned in what

abcdefghijklmnopqrstuvwxy  
ABCDEFGHIJKLMNOPQRSTUVWXYZ  
#1234567890



14 Point No. 97

**SIXTY EMS OF PICA**

**Is the Monotype Measure for Composition. You can Set any Job  
Within this Limit in any Size Type  
\$1234567890**

18 Point No. 97

**SETS SEVEN ALPHABETS**

**Roman, Italic and Boldface, Caps and Lower Case  
and Roman Small Caps at Once  
\$1234567890**

24 Point No. 97

**THE MATRIX LIBRARY**

**Gives you Quickly the Face you Want  
When you Really Want it  
\$1234567890**

30 Point No. 97

**CORRECTIONS MADE**

**By Hand While the Monotype  
Runs on Original Copy  
\$1234567890**

36 Point No. 97

**A NEW DRESS**

**For Everything in the Shop  
\$1234567890**

# No. 97K. Job Arrangement C2

## Composition Matrices

6 Point No. 97K, 7 Set

### MONOTYPE FACES

*The best kind of originality is that which comes after a sound apprenticeship; that which shall prove to be the blending of a firm conception of all useful precedent and the progressive tendencies of an able mind. For, let a man be as able and original as he may, he cannot afford to discard knowledge of what has gone before or what is now going on in his own trade and profession. If the printers of today do not wish to be esteemed arrogant when they term this calling of theirs an art, they must be willing, and show that they are willing, to subject it to such laws as have made its sister arts so free. All those concerned in what are accepted as the fine arts, the learned sciences, and professions surround themselves with the history, literature, and the concrete examples of the work with which they are particularly engaged. Yet it is only in very rare instances that this atmosphere, with its material appurtenances, is to be found in a printing office. Art does not flourish in hidden places, nor under restraint, nor in ignorance of what talent and genius have accomplished and are accomplishing throughout the world. For to follow precedent wisely does not mean to imitate slavishly one great exemplar, but to study all masters faithfully, letting their great achievements sink slowly into the mind in order that we may patiently derive from the richness of our acquired knowledge and organized system an attitude of our own. The sprightly minded young man, who with his first business breath projects the new and startling, inevitably becomes tiresome, and is driven to an early disappearance; while the slower, more solidly endowed student will at least spend as much of his time in avoiding mistakes as in evolving brilliant schemes wherewith to dazzle his contemporaries. The best kind of originality is that which comes after a sound apprenticeship; that which shall prove to*

abcdefghijklmnopqrstuvwxyz

ABCDEFGHIJKLMNOPQRSTUVWXYZ

\$1234567890

10 Point No. 97K, 10 Set

### MONOTYPE FACES

*The best kind of originality is that which comes after a sound apprenticeship; that which shall prove to be the blending of a firm conception of all useful precedent and the progressive tendencies of an able mind. For, let any man be as able and original as he may, he cannot afford to discard knowledge of what has gone before or what is now going on in his own trade and profession. If the printers of today do not wish to be esteemed too arrogant when they term this calling of theirs an art, they must be willing, and show that they are willing, to subject it to such laws as have made its sister arts so free. All those concerned in what are accepted as the fine arts, the learned sciences, and professions surround themselves with the history, literature, and concrete examples of the work with which they are particularly engaged. Yet it is only in very rare instances that such an atmosphere, with*

abcdefghijklmnopqrstuvwxyz

ABCDEFGHIJKLMNOPQRSTUVWXYZ

\$1234567890

8 Point No. 97K, 8½ Set

### MONOTYPE FACES

*The best kind of originality is that which comes after a sound apprenticeship; that which shall prove to be the blending of a firm conception of all useful precedent and the progressive tendencies of an able mind. For, let a man be as able and original as he may, he cannot afford to discard knowledge of what has gone before or what is now going on in his own trade and profession. If the printers of today do not wish to be esteemed arrogant when they term this calling of theirs an art, they must be willing, and show that they are willing, to subject it to such laws as have made its sister arts so free. All those concerned in what are accepted as the fine arts, the learned sciences, and professions surround themselves with the history, literature, and concrete examples of the work with which they are particularly engaged. Yet it is only in rare instances that such an atmosphere, with its material appurtenances, is to be found in a printing office. Art does not flourish in hidden places, nor under restraint, nor in ignorance of what talent and genius have accomplished and are accomplishing throughout the world. For to follow precedent wisely does not mean to imitate slavishly one great exemplar,*

abcdefghijklmnopqrstuvwxyz

ABCDEFGHIJKLMNOPQRSTUVWXYZ

\$1234567890

12 Point No. 97K, 12 Set

### MONOTYPE FACES

*The best kind of originality is that which comes after a sound apprenticeship; that which shall prove to be the blending of a firm conception of all useful precedent and the progressive tendencies of an able mind. For, let a man be as able and original as he may, he cannot afford to discard a knowledge of what has gone before or what is now going on in his own trade and profession. If the printers of today do not wish to be esteemed arrogant when they term this calling of theirs an art, they must be willing, and show that they are willing, to subject it to such laws as have made its sister arts so free. All those who are concerned in what*

abcdefghijklmnopqrstuvwxyz

ABCDEFGHIJKLMNOPQRSTUVWXYZ

\$1234567890

# No. 98J. Book Arrangement C

## Composition Matrices

6 Point No. 98J, 7½ Set

### MONOTYPE FACES

The best kind of originality is that which comes after a sound apprenticeship; that which shall prove to be the blending of a firm conception of all useful precedent and the progressive tendencies of an able mind. For, let a man be as able and original as he may, he cannot afford to discard knowledge of what has gone before or what is now going on in his own trade and profession. If the printers of today do not wish to be esteemed arrogant when they term this calling of theirs an art, they must be willing, and show that they are willing, to subject it to such laws as have made its sister arts so free. All those concerned in what are accepted as the fine arts, the learned sciences and professions, surround themselves with the history, the literature, and concrete examples of the work with which they are particularly engaged. Yet it is only in rare instances that such an atmosphere, with its material appurtenances, is to be found in a printing office. Art does not flourish in hidden places, nor under restraint, nor in ignorance of what talent and genius have accomplished and are accomplishing throughout the world. For to follow precedent wisely does not mean to imitate slavishly one great exemplar, but to study all masters faithfully,

abcdefghijklmnopqrstuvwxy  
ABCDEFGHIJKLMNPOQRSTUVWXYZ  
\$1234567890

8 Point No. 98J, 8½ Set

### MONOTYPE FACES

The best kind of originality is that which comes after a sound apprenticeship; that which shall prove to be the blending of a firm conception of all useful precedent and the progressive tendencies of an able mind. For, let a man be as able and original as he may, he cannot afford to discard knowledge of what has gone before or what is now going on in his own trade and profession. If the printers of today do not wish to be esteemed arrogant when they term this calling of theirs an art, they must be willing, and show that they are willing, to subject it to such laws as have made its sister arts so free. All those concerned in what are accepted as the fine arts, the learned sciences and the professions, surround themselves with the

abcdefghijklmnopqrstuvwxy  
ABCDEFGHIJKLMNPOQRSTUVWXYZ  
\$1234567890

9 Point No. 98J, 9 Set

### MONOTYPE FACES

The best kind of originality is that which comes after a sound apprenticeship; that which shall prove to be the blending of a firm conception of all useful precedent and the progressive tendencies of an able mind. For, let a man be as able and original as he may, he cannot afford to discard knowledge of what has gone before or what is now going on in his own trade and profession. If the printers of today do not wish to be esteemed arrogant when they term this calling of theirs an art, they must be willing, and show that they are willing, to subject it to such laws as have made its sister arts

abcdefghijklmnopqrstuvwxy  
ABCDEFGHIJKLMNPOQRSTUVWXYZ  
\$1234567890

10 Point No. 98J, 10½ Set

### MONOTYPE FACES

The best kind of originality is that which comes after a sound apprenticeship; that which shall prove to be the blending of a firm conception of all useful precedent and the progressive tendencies of an able mind. For, let a man be as able and original as he may, he cannot afford to discard knowledge of what has gone before or what is now going on in his own trade and profession. If the printers of today do not wish to be esteemed arrogant when they term this calling of theirs an art, they must be willing, and show that they are willing, to subject it to such laws as have made its sister arts so free. All those concerned in what are accepted as the fine arts, the learned sciences and professions, surround themselves with the history, literature, and concrete examples of the work with which they are particularly engaged. Yet it is only in very rare instances that such an atmosphere, with its material appurtenances, is to be found in a

abcdefghijklmnopqrstuvwxy  
ABCDEFGHIJKLMNPOQRSTUVWXYZ  
\$1234567890

12 Point No. 98J, 12 Set

### MONOTYPE FACES

The best kind of originality is that which comes after a sound apprenticeship; that which shall prove to be the blending of a firm conception of all useful precedent and the progressive tendencies of an able mind. For, let any man be as able and original as he may, he cannot afford to discard knowledge of what has gone before or what is now going on in his own trade and profession. If the printers of today do not wish to be esteemed arrogant when they term this calling of theirs an art, they must be willing, and show that they are willing, to subject it to such laws as have made its sister arts so free. All those concerned in what are accepted as the fine arts, the learned sciences and

abcdefghijklmnopqrstuvwxy  
ABCDEFGHIJKLMNPOQRSTUVWXYZ  
\$1234567890

14 Point No. 98

**THE MONOTYPE WILL ALLOW DUPLICATION  
Of Forms for Long Runs without Loss of Time for Electrotyping or  
Resetting the Job by Hand  
\$1234567890**

18 Point No. 98

**NO MACHINE THE PRINTER USES  
Will Save as Much Time and Money as the Monotype.  
It Produces all the Time  
\$1234567890**

24 Point No. 98

**EACH TYPE CAST  
Separately, like Foundry Type, and  
with Greater Accuracy  
\$1234567890**

30 Point No. 98

**ALL PROGRESSIVE  
Printers use a Versatile Monotype  
for all kinds of work  
\$1234567890**

36 Point No. 98

**TABULAR MATTER  
Composed like plain matter  
\$1234567890**

# No. 98K. Job Arrangement C2

## Composition Matrices

6 Point No. 98K, 7 Set

### MONOTYPE FACES

The best kind of originality is that which comes after a sound apprenticeship; that which shall prove to be the blending of a firm conception of all useful precedent and the progressive tendencies of an able mind. For, let a man be as able and original as he may, he cannot afford to discard knowledge of what has gone before or what is now going on in his own trade or his profession. If the printers of today do not wish to be esteemed arrogant when they term this calling of theirs an art, they must be willing, and show that they are willing, to subject it to such laws as have made its sister arts so free. All those concerned in what are accepted as the fine arts, the learned sciences, and professions surround themselves with the history, the literature, and concrete examples of the work with which they are particularly engaged. Yet it is only in very rare instances that such an atmosphere, with its material appurtenances, is to be found in a printing office. Art does not flourish in hidden places, nor under restraint, nor in ignorance of what talent and genius have accomplished and are accomplishing throughout the world. For to follow all precedent wisely does

abcdefghijklmnopqrstuvwxy  
ABCDEFGHIJKLMNQPQRSTUVWXYZ  
\$1234567890

8 Point No. 98K, 8 1/2 Set

### MONOTYPE FACES

The best kind of originality is that which comes after a thorough apprenticeship; that which shall prove to be the blending of a firm conception of all useful precedent and the progressive tendencies of an able mind. For, let a man be as able and original as he may, he cannot afford to discard knowledge of what has gone before or what is now going on in his own trade or his profession. If the printers of today do not wish to be esteemed arrogant when they term this calling of theirs an art, they must be willing, and show that they are willing, to subject it to such laws as have made its sister arts so free. All those concerned in what are accepted as the fine arts, the learned sciences, and professions, surround

abcdefghijklmnopqrstuvwxy  
ABCDEFGHIJKLMNQPQRSTUVWXYZ  
\$1234567890

9 Point No. 98K, 9 Set

### MONOTYPE FACES

The best kind of originality is that which comes after a sound apprenticeship; that which shall prove to be the blending of a firm conception of all useful precedent and of the progressive tendencies of an able mind. For, let a man be as able and original as he may, he cannot afford to discard knowledge of what has gone before or what is now going on in his own trade and profession. If the printers of today do not wish to be esteemed arrogant when they term this calling of theirs an art, they must be willing, and show that they are willing, to subject it to such laws

abcdefghijklmnopqrstuvwxy  
ABCDEFGHIJKLMNQPQRSTUVWXYZ  
\$1234567890

10 Point No. 98K, 10 Set

### MONOTYPE FACES

The best kind of originality is that which comes after a thorough apprenticeship; that which shall prove to be the blending of a firm conception of all useful precedent and the progressive tendencies of an able mind. For, let a man be as able and original as he may, he cannot afford to discard knowledge of what has gone before or what is now going on in his own trade and profession. If the printers of today do not wish to be esteemed too arrogant when they term this calling of theirs an art, they must be willing, and show that they are willing, to subject it to such laws as have made its sister arts so free. All those concerned in what are accepted as the fine arts, the learned sciences, and professions surround themselves with the history, literature, and concrete examples of the work with which they are particularly engaged. Yet it is only in rare instances that such an

abcdefghijklmnopqrstuvwxy  
ABCDEFGHIJKLMNQPQRSTUVWXYZ  
\$1234567890

12 Point No. 98K, 12 Set

### MONOTYPE FACES

The best kind of originality is that which comes after a sound apprenticeship; that which shall prove to be the blending of a firm conception of all useful precedent and the progressive tendencies of an able mind. For, let a man be as able and original as he may, he cannot afford to discard a knowledge of what has gone before or what is now going on in his own trade and profession. If the printers of today do not wish to be esteemed arrogant when they term this calling of theirs an art, they must be willing, and show that they are willing, to subject it to such laws as have made its sister arts so free.

abcdefghijklmnopqrstuvwxy  
ABCDEFGHIJKLMNQPQRSTUVWXYZ  
\$1234567890

# No. 298J. Job Arrangement C4

## Composition Matrices

12 Point No. 298J, 10 Set

### MONOTYPE FACES

THE BEST KIND OF ORIGINALITY IS THAT WHICH COMES AFTER A SOUND APPRENTICESHIP; THAT WHICH SHALL PROVE TO BE THE BLENDING OF A FIRM CONCEPTION OF ALL USEFUL PRECEDENT AND THE PROGRESSIVE TENDENCIES OF AN ABLE MIND. FOR, LET A MAN BE AS ABLE AND ORIGINAL AS HE MAY, HE CANNOT AFFORD TO DISCARD KNOWLEDGE OF WHAT HAS GONE BEFORE OR WHAT IS NOW GOING ON IN HIS OWN TRADE AND PROFESSION. IF THE PRINTERS OF TODAY DO NOT WISH TO BE ESTEEMED ARROGANT WHEN THEY TERM THIS CALLING OF THEIRS AN ART, THEY MUST BE WILLING, AND SHOW THAT THEY ARE WILLING, TO SUBJECT IT TO SUCH LAWS AS HAVE MADE ITS SISTER ARTS SO FREE. ALL THOSE CONCERNED IN WHAT ARE ACCEPTED AS THE FINE ARTS, THE LEARNED SCIENCES

### MONOTYPE FACES

THE BEST KIND OF ORIGINALITY IS THAT WHICH COMES AFTER A SOUND APPRENTICESHIP; THAT WHICH SHALL PROVE TO BE THE BLENDING OF A FIRM CONCEPTION OF ALL USEFUL PRECEDENT AND THE PROGRESSIVE TENDENCIES OF AN ABLE MIND. FOR, LET A MAN BE AS ABLE AND ORIGINAL AS HE MAY, HE CANNOT AFFORD TO DISCARD KNOWLEDGE OF WHAT HAS GONE BEFORE OR WHAT IS NOW GOING ON IN HIS OWN TRADE AND PROFESSION. IF THE PRINTERS OF TODAY DO NOT WISH TO BE ESTEEMED ARROGANT WHEN THEY TERM THIS CALLING OF THEIRS AN ART, THEY MUST BE WILLING, AND SHOW THAT THEY ARE WILLING, TO SUBJECT IT TO SUCH LAWS AS HAVE MADE ITS SISTER ARTS SO FREE. ALL THOSE CONCERNED IN WHAT ARE ACCEPTED AS THE FINE ARTS, THE LEARNED SCIENCES AND THE PROFESSIONS, SURROUND THEMSELVES WITH THE HISTORY, LITERATURE, AND THE CONCRETE EXAMPLES OF THE WORK WITH

ABCDEFGHIJKLMNPOQRSTUVWXYZ

\$1234567890

NOTE: The figures and dollar mark are symboled 12 point No 98J

No. 298

Electro Display Matrices

14 Point No. 298

**NEW COLUMN RULE CAN BE CAST  
ON THE MONOTYPE TYPE-&-RULE CASTER IN JUST THE LENGTH AND QUANTITY  
YOU DESIRE; ALSO BORDER, RULES, LEADS AND SLUGS  
\$1234567890**

18 Point No. 298

**MAKE YOUR OWN TYPE  
FOR THE NON-DISTRIBUTION WAY IS THE EASIEST WAY  
TO OBTAIN GOOD TYPOGRAPHY  
\$1234567890**

24 Point No. 298

**NON-DISTRIBUTION  
GREATEST PROFIT MAKING SYSTEM  
EVER OFFERED  
\$1234567890**

30 Point No. 298

**WISE PRINTERS  
CUT COMPOSING ROOM COSTS  
AND INCREASE PROFITS  
\$1234567890**

36 Point No. 298

**THIS SERIES  
CONTAINS CAPS & POINTS  
\$1234567890**

The figures shown above, with the No. 298 series, are the same as used with our No. 98 series.

18 Point No. 104

ADDING FACES EVERY WEEK  
TO KEEP THE MONOTYPE EQUIPMENT UP TO THE  
MINUTE WITH UP-TO-DATE FACES  
\$1234567890

20 Point No. 104

A CONVERTIBLE MACHINE  
FROM A TYPE CASTER TO A COMPOSING  
MACHINE  
\$1234567890

24 Point No. 104

YOUR INVESTMENT  
PROTECTED BY THIS CONVERTIBLE  
FEATURE  
\$1234567890



# No. 117J. Job Arrangement C1

## Composition Matrices

6 Point No. 117J, 7 Set

### MONOTYPE FACES

The best kind of originality is that which comes after a sound apprenticeship; that which shall prove itself to be the blending of a firm conception of useful precedent and the progressive tendencies of an able mind. For, let a man be as able and original as he may, he cannot afford to discard knowledge of what has gone before or what is now going on in his own trade and profession. If the printers of today do not wish to be esteemed arrogant when they term this calling of theirs an art, they must be willing, and show that they are willing, to subject it to such laws as have made its sister arts so free. All those concerned in what are accepted as the fine arts, the learned sciences, and professions surround themselves with the history, literature, and concrete examples of the work with which they are particularly engaged. Yet it is only in rare instances that such an atmosphere, with its material appurtenances, is to be found in a printing office. Art does not flourish in hidden places, nor under restraint, nor in ignorance of what talent and genius have accomplished and are accomplishing throughout the world. For to follow precedent wisely does not mean to imitate slavishly one great exemplar, but to study all masters faithfully, letting their great achievements sink slowly into the mind in order that we may patiently derive from the richness of our acquired knowledge and organized system an attitude of our own. The sprightly minded young man, who with his first business breath projects the new and startling, inevitably becomes tiresome, and is driven to an early disappearance; while the slower, more solidly endowed student will at least spend as much of his time in avoiding mistakes as in evolving brilliant schemes wherewith to dazzle his contemporaries. The best kind of originality is that which comes after a sound apprenticeship; that which shall prove to be the blending of a firm conception of all useful precedent and the progressive tendencies of an able mind. For, let a man be as able and original as he may, he cannot afford to discard knowledge of what has gone before or what is now going on in his own trade and profession.

abcdefghijklmnopqrstuvwxy

ABCDEFGHIJKLMNPOQRSTUVWXYZ

\$1234567890

10 Point No. 117J, 10 Set

### MONOTYPE FACES

The best kind of originality is that which comes after a sound apprenticeship; that which shall prove to be the blending of a firm conception of all useful precedent and the progressive tendencies of an able mind. For, let a man be as able and original as he may, he cannot afford to discard knowledge of what has gone before or what is now going on in his own trade and profession. If the printers of today do not wish to be esteemed arrogant when they term this calling of theirs an art, they must be willing, and show that they are willing, to subject it to such laws as have made its sister arts so free. All those concerned in what are accepted as the fine arts, the learned sciences, and professions surround themselves with the history, literature, and concrete examples of the work with which they are particularly engaged. Yet it is only in rare instances that such an atmosphere, with its material appurtenances, is to be found in a printing office. Art does not flourish in hidden places, nor under restraint, nor even in ignorance of what

abcdefghijklmnopqrstuvwxy

ABCDEFGHIJKLMNPOQRSTUVWXYZ

\$1234567890

8 Point No. 117J, 8 1/2 Set

### MONOTYPE FACES

The best kind of originality is that which comes after a sound apprenticeship; that which shall prove to be the blending of a firm conception of all useful precedent and the progressive tendencies of an able mind. For, let a man be as able and original as he may, he cannot afford to discard knowledge of what has gone before or what is now going on in his own trade and profession. If the printers of today do not wish to be esteemed arrogant when they term this calling of theirs an art, they must be willing, and show that they are willing, to subject it to such laws as have made its sister arts so free. All those concerned in what are accepted as the fine arts, the learned sciences, and professions surround themselves with the history, the literature, and concrete examples of the work with which they may be particularly engaged. Yet it is only in rare instances that such an atmosphere, with its material appurtenances, is to be found in a printing office. Art does not flourish in hidden places, nor under restraint, nor in ignorance of what talent and genius have accomplished and are now accomplishing throughout the world. For to follow precedent wisely does not mean to imitate slavishly one great exemplar, but to study all the masters faithfully, letting their great achievements sink slowly into the mind in order that we may patiently derive from the

abcdefghijklmnopqrstuvwxy

ABCDEFGHIJKLMNPOQRSTUVWXYZ

\$1234567890

12 Point No. 117J, 12 Set

### MONOTYPE FACES

The best kind of originality is that which comes after a sound apprenticeship; that which shall prove to be the blending of a firm conception of all useful precedent and the progressive tendencies of an able mind. For, let any man be as able and original as he may, he cannot afford to discard knowledge of what has gone before or what is now going on in his own trade and profession. If the printers of today do not wish to be esteemed arrogant when they term this calling of theirs an art, they must be willing, and show that they are willing, to subject it to such laws as have made its sister arts so free. All those concerned in what are accepted as the fine arts, the learned sciences, and the professions, surround themselves with the

abcdefghijklmnopqrstuvwxy

ABCDEFGHIJKLMNPOQRSTUVWXYZ

\$1234567890

14 Point No. 117

**THERE IS A BIG DIFFERENCE**  
Between the Actual Cost and the Selling Price of Monotype Composition  
Quality Certainly Pays Handsomely  
\$1234567890

18 Point No. 117

**THE CELLULAR MATRIX**  
The most Radical and the most Costly Improvement Ever  
Made in Composing Machinery  
\$1234567890

24 Point No. 117

**THE QUALITY MACHINE**  
That Pleases Quality Customers and Keeps  
Cost Down and Price Up  
\$1234567890

30 Point No. 117

**ATTRACTIVE FACES**  
Infinite Variety and Artistic Design  
Producing Work that Sells  
\$1234567890

36 Point No. 117

**LOW QUAD MOLD**  
Saves Time in Press Room  
\$1234567890

# No. 117K. Book Arrangement C [Italic]

## Composition Matrices

6 Point No. 117K, 7 Set

### MONOTYPE FACES

*The best kind of originality is that which comes after a sound apprenticeship; that which shall prove itself to be the blending of a firm conception of useful precedent and the progressive tendencies of an able mind. For, let a man be as able and original as he may, he cannot afford to discard knowledge of what has gone before or what is now going on in his own trade and profession. If the printers of today do not wish to be esteemed arrogant when they term this calling of theirs an art, they must be willing, and show that they are willing, to subject it to such laws as have made its sister arts so free. All those concerned in what are accepted as the fine arts, the learned sciences, and professions surround themselves with the history, literature, and concrete examples of work with which they are particularly engaged. Yet it is only in very rare instances that such an atmosphere, with its material appurtenances, is to be found in the printing office. Art does not flourish in hidden places, nor under restraint, nor in ignorance of what talent and genius have accomplished and are accomplishing throughout the world. For to follow precedent wisely does not mean to imitate slavishly one great exemplar, but to study all the masters faithfully, letting their great achievements sink slowly into the mind in order that we may patiently derive from the richness of our acquired knowledge and organized system an attitude of our own. The sprightly minded young man, who with his first business breath projects the new and startling, inevitably becomes tiresome, and is driven to an early disappearance; while the slower and more solidly endowed student will at least spend as much of his time in avoiding mistakes as in evolving brilliant schemes wherewith to dazzle his contemporaries. The best kind of originality is that which comes after a sound apprenticeship; that which shall prove itself to be the blending of a firm conception of all useful precedent and the progressive tendencies of an able mind. For, let any man be as able and original as he may, he cannot afford to discard knowledge of what has gone before or what is now going on in his own trade and profession. If the printers of today do not wish to be esteemed arrogant when they term this calling of theirs an*

abcdefghijklmnopqrstuwxyz

ABCDEFGHIJKLMNOPQRSTUVWXYZ

\$1234567890

10 Point No. 117K, 10 Set

### MONOTYPE FACES

*The best kind of originality is that which comes after a sound apprenticeship; that which shall prove to be the blending of a firm conception of all useful precedent and the progressive tendencies of an able mind. For, let a man be as able and original as he may, he cannot afford to discard knowledge of what has gone before or what is now going on in his own trade and profession. If the printers of today do not wish to be esteemed arrogant when they term this calling of theirs an art, they must be willing, and show that they are willing, to subject it to such laws as have made its sister arts so free. All those who are concerned in what are accepted as the fine arts, the learned sciences, and the professions surround themselves with the history, the literature, and concrete examples of the work with which they are particularly engaged. Yet it is only in rare instances that such an atmosphere, with its material appurtenances, is to be found in a printing office. Art does not flourish in hidden places, nor under restraint, nor in ignorance of what talent and genius have accomplished and are now accomplishing in*

abcdefghijklmnopqrstuwxyz

ABCDEFGHIJKLMNOPQRSTUVWXYZ

\$1234567890

8 Point No. 117K, 8½ Set

### MONOTYPE FACES

*The best kind of originality is that which comes after a sound apprenticeship; that which shall prove to be the blending of a firm conception of all useful precedent and the progressive tendencies of an able mind. For, let a man be as able and original as he may, he cannot afford to discard knowledge of what has gone before or what is now going on in his own trade and profession. If the printers of today do not wish to be esteemed arrogant when they term this calling of theirs an art, they must be willing, and show that they are willing, to subject it to such laws as have made its sister arts so free. All those concerned in what are accepted as the fine arts, the learned sciences, and the professions surround themselves with the history, the literature, and concrete examples of the work with which they are particularly engaged. Yet it is only in very rare instances that such an atmosphere, with its material appurtenances, is to be found in a printing office. Art does not flourish in hidden places, nor under restraint, nor in ignorance of what talent and genius have accomplished and are now accomplishing throughout the world. For to follow all precedent wisely does not mean to imitate slavishly one great exemplar, but to study all masters faithfully, letting their great achievements sink slowly into the mind in order that we may patiently derive from the richness of our acquired knowledge and organized system an attitude*

abcdefghijklmnopqrstuwxyz

ABCDEFGHIJKLMNOPQRSTUVWXYZ

\$1234567890

12 Point No. 117K, 12 Set

### MONOTYPE FACES

*The best kind of originality is that which comes after a sound apprenticeship; that which shall prove to be the blending of a firm conception of all useful precedent and the progressive tendencies of an able mind. For, let any man be as able and original as he may, he cannot afford to discard knowledge of what has gone before or what is now going on in his own trade and profession. If the printers of today do not wish to be esteemed arrogant when they term this calling of theirs an art, they must be willing, and show that they are willing, to subject it to such laws as have made its sister arts so free. All those concerned in what are accepted as the fine arts, the learned sciences, and the professions surround themselves with the*

abcdefghijklmnopqrstuwxyz

ABCDEFGHIJKLMNOPQRSTUVWXYZ

\$1234567890

# No. 139J. Job Arrangement C1

## Composition Matrices

6 Point No. 139J, 6½ Set

### MONOTYPE FACES

The best kind of originality is that which comes after a sound apprenticeship; that which shall prove to be the blending of a firm conception of all useful precedent and the progressive tendencies of an able mind. For, let a man be as able and original as he may he cannot afford to discard knowledge of what has gone before or what is now going on in his own trade and profession. If the printers of today do not wish to be esteemed arrogant when they term this calling of theirs an art, they must be willing, and show that they are willing, to subject it to such laws as have made its sister arts so free. All those concerned in what are accepted as the fine arts, the learned sciences, and professions surround themselves with the history, literature, and concrete examples of the work with which they are particularly engaged. Yet it is only in rare instances that such an atmosphere, with its material appurtenances, is to be found in a printing office. Art does not flourish in hidden places, nor under restraint, nor in ignorance of what talent and genius have accomplished and are accomplishing throughout the world. For to follow precedent wisely does not mean to imitate slavishly one great exemplar, but to study all masters faithfully, letting their great achievements sink slowly into the mind in order that we may patiently derive from the richness of our acquired knowledge and organized system an attitude of our own. The sprightly minded young man, who with his first business breath projects the new and startling, inevitably becomes tiresome and is driven in an early disappearance; while the slower, more solidly endowed student will at least spend as much of his time in avoiding mistakes as in evolving brilliant schemes wherewith to dazzle his contemporaries. The best kind of originality is that which comes after a sound apprenticeship; that which shall prove to be the blending of a firm conception of all useful precedent and the progressive tendencies of an able mind. For, let a man be as able and original as he may, he cannot afford to discard knowledge of what has gone before or what is now going on in his own trade and profession. If the printers of today do not wish to be esteemed arrogant when they term this calling of theirs

abcdefghijklmnopqrstuvwxy

ABCDEFGHIJKLMNPOQRSTUVWXYZ

\$1234567890

10 Point No. 139J, 9½ Set

### MONOTYPE FACES

The best kind of originality is that which comes after a sound apprenticeship; that which shall prove to be the blending of a firm conception of all useful precedent and the progressive tendencies of an able mind. For, let a man be as able and original as he may, he cannot afford to discard knowledge of what has gone before or what is now going on in his own trade and profession. If the printers of today do not wish to be esteemed arrogant when they term this calling of theirs an art, they must be willing, and show that they are willing, to subject it to such laws as have made its sister arts so free. All those concerned in what are accepted as the fine arts, the learned sciences, and professions surround themselves with the history, literature, and concrete examples of the work with which they are particularly engaged. Yet it is only in rare instances that such an atmosphere, with its material appurtenances, is to be found in a printing office. Art does not flourish in hidden places, nor under restraint, nor even in ignorance of what talent and genius have accomplished and are accomplishing

abcdefghijklmnopqrstuvwxy

ABCDEFGHIJKLMNPOQRSTUVWXYZ

\$1234567890

8 Point No. 139J, 8 Set

### MONOTYPE FACES

The best kind of originality is that which comes after a sound apprenticeship; that which shall prove itself to be the blending of a firm conception of useful precedent and the progressive tendencies of an able mind. For, let a man be as able and original as he may, he cannot afford to discard knowledge of what has gone before or what is now going on in his own trade and profession. If the printers of today do not wish to be esteemed arrogant when they term this calling of theirs an art, they must be willing, and show that they are willing, to subject it to such laws as have made its sister arts so free. All those concerned in what are accepted as the fine arts, the learned sciences, and professions surround themselves with the history, literature, and concrete examples of the work with which they are particularly engaged. Yet it is only in rare instances that such an atmosphere, with its material appurtenances, is to be found in a printing office. Art does not flourish in hidden places, nor under restraint, nor in ignorance of what talent and genius have accomplished and are accomplishing throughout the world. For to follow precedent wisely does not mean to imitate slavishly one great exemplar, but to study all the masters faithfully, letting their great achievements sink slowly into the mind in order that we may patiently derive from the richness of our acquired knowledge and organized system an attitude of our own. The very

abcdefghijklmnopqrstuvwxy

ABCDEFGHIJKLMNPOQRSTUVWXYZ

\$1234567890

12 Point No. 139J, 11 Set

### MONOTYPE FACES

The very best kind of originality is that which comes after a thorough apprenticeship; that which shall prove itself to be the blending of a firm conception of all useful precedent and the progressive tendencies of an able mind. For, let a man be as able and original as he may, he cannot afford to discard knowledge of what has gone before or what is now going on in his own trade and profession. If the printers of today do not wish to be esteemed arrogant when they term this calling of theirs an art, they must be willing, and show that they are willing, to subject it to such laws as have made its sister arts so free. All those concerned in what are accepted as the fine arts, the learned sciences, and the professions surround themselves with the history, literature, and concrete examples of the work with

abcdefghijklmnopqrstuvwxy

ABCDEFGHIJKLMNPOQRSTUVWXYZ

\$1234567890

24 Point No. 139

**MONOTYPE RELIABILITY**

**The Machine That is Equal to the Most Exacting  
Typographical Requirements**

**\$1234567890**

30 Point No. 139

**OUR MONOTYPE MATRIX**

**Will Cast Figures as Large as 36 Point  
and in Justified Lines**

**\$1234567890**

36 Point No. 139

**FOR MORE PROFIT**

**Always Use Monotype Composition**

**\$1234567890**

NOTE: The capitals R, M, and O in the above series are made in two styles. Both styles are included in the fonts.  
Minimum fonts contain 75 matrices.

# No. 142J. Job Arrangement C2

## Composition Matrices

5½ Point No. 142J, 7½ Set

### MONOTYPE FACES

The best kind of originality is that which comes after a sound apprenticeship; that which shall prove to be the blending of a firm conception of all useful precedent and the progressive tendencies of an able mind. For, let a man be as able and original as he may, he cannot afford to discard knowledge of what has gone before or what is now going on in his own trade and profession. If the printers of today do not wish to be esteemed arrogant when they term this calling of theirs an art, they must be willing, and show that they are willing, to subject it to such laws as have made its sister arts so free. All those concerned in what are accepted as the fine arts, the learned sciences, and professions surround themselves with the history, the literature, and concrete examples of the work

abcdefghijklmnopqrstuvwxy  
ABCDEFGHIJKLMNOPQRSTUVWXYZ  
\$1234567890

8 Point No. 142J, 9½ Set

### MONOTYPE FACES

The best kind of originality is that which comes after a sound apprenticeship; that which shall prove to be the blending of a firm conception of all useful precedent and the progressive tendencies of an able mind. For, let a man be as able and original as he may, he cannot afford to discard knowledge of what has gone before or what is now going on in his own trade and profession. If the printers of today do not wish to be esteemed arrogant when they term this calling of theirs an art, they must be willing, and show that they are willing, to subject it to such laws as have made its sister arts so free. All

abcdefghijklmnopqrstuvwxy  
ABCDEFGHIJKLMNOPQRSTUVWXYZ  
\$1234567890

12 Point No. 142J, 12 Set

### MONOTYPE FACES

The best kind of originality is that which comes after a sound apprenticeship; that which shall prove to be the blending of a firm conception of all useful precedent and the progressive tendencies of an able mind. For, let a man be as able and original as he may, he cannot afford to discard a knowledge of what has gone before or what is now going on in his own trade and profession. If the printers of today do not wish to be

abcdefghijklmnopqrstuvwxy  
ABCDEFGHIJKLMNOPQRSTUVWXYZ  
1234567890\$

6 Point No. 142J, 7½ Set

### MONOTYPE FACES

The best kind of originality is that which comes after a sound apprenticeship; that which shall prove to be the blending of a firm conception of all useful precedent and the progressive tendencies of an able mind. For, let any man be as able and original as he may, he cannot afford to discard knowledge of what has gone before or what is now going on in his own trade and profession. If the printers of today do not wish to be esteemed arrogant when they term this calling of theirs an art, they must be willing, and show that they are willing, to subject it to such laws as have made its sister arts so free. All those concerned in what are accepted as the fine arts, the

abcdefghijklmnopqrstuvwxy  
ABCDEFGHIJKLMNOPQRSTUVWXYZ  
\$1234567890

10 Point No. 142J, 11 Set

### MONOTYPE FACES

The very best kind of originality is that which comes after a sound apprenticeship; that which shall prove itself to be the blending of a firm conception of all useful precedent and the progressive tendencies of an able mind. For, let a man be as able and as original as he may, he cannot afford to discard all knowledge of what has gone before or what is now going on in his own trade and profes-

abcdefghijklmnopqrstuvwxy  
ABCDEFGHIJKLMNOPQRSTUVWXYZ  
\$1234567890

### MONOTYPE FACES

The best kind of originality is that which comes after a sound apprenticeship; that which shall prove to be the blending of a firm conception of all useful precedent and the progressive tendencies of an able mind. For, let a man be as able and original as he may, he cannot afford to discard a knowledge of what has gone before or what is now going on in his own trade and profession. If the printers of today do not wish to be esteemed arrogant when they term this calling of theirs an art, they

14 Point No. 144

**YOU DON'T HAVE TO BUY  
Special Attachments, Rules and Furniture to Handle  
out of the Ordinary Work  
\$1234567890**

18 Point No. 144

**SAVING ON MAKE-READY  
With Always New Type is a Double Saving;  
Press Time and Man Time  
\$1234567890**

24 Point No. 144

**TIME, MONEY, WORRY  
Saved on Composition, Supervision  
& Corrections with Monotype  
\$1234567890**

30 Point No. 144

**QUALITY FAMOUS  
But Not Wanting on Quantity  
Under All Conditions  
\$1234567890**

36 Point No. 144

**PRESS CHANGES  
Easy with Separate Type  
\$1234567890**

# No. 145J. Job Arrangement C2

## Composition Matrices

6 Point No. 145J, 7 Set

### MONOTYPE FACES

The best kind of originality is that which comes after a sound apprenticeship; that which shall prove to be the blending of a firm conception of all useful precedent and the progressive tendencies of an able mind. For, let a man be as able and original as he may, he cannot afford to discard knowledge of what has gone before or what is now going on in his own trade or his profession. If the printers of today do not wish to be esteemed arrogant when they term this calling of theirs an art, they must be willing, and show that they are willing, to subject it to such laws as have made its sister arts so free. All those concerned in what are accepted as the fine arts, the learned sciences, and professions surround themselves with the history, the literature, and concrete examples of the work with which they are particularly engaged. Yet it is only in very rare instances that such an atmosphere, with its material appurtenances, is to be found in a printing office. Art does not flourish in hidden places, nor under restraint, nor in ignorance of what talent and genius have accomplished and are accomplishing throughout the world. For to follow all precedent wisely does not mean to imitate too slavishly one great exemplar, but to study all masters faithfully, letting their great achievements sink slowly into the mind in order that we may patiently derive from the richness of our acquired knowledge and organized system an attitude of our own. The sprightly minded young man, who with his first business breath projects the new and startling, inevitably becomes tiresome, and is driven to an early disappearance; while the slower, more solidly endowed student will at least spend as much of his time in avoiding mistakes as in evolving brilliant schemes wherewith to dazzle his contemporaries. The best kind of originality is that which comes after a sound apprenticeship; that which shall prove to

abcdefghijklmnopqrstuvwxyz

ABCDEFGHIJKLMNOPQRSTUVWXYZ

\$1234567890

10 Point No. 145J, 10 Set

### MONOTYPE FACES

The best kind of originality is that which comes after a thorough apprenticeship; that which shall prove to be the blending of a firm conception of all useful precedent and the progressive tendencies of an able mind. For, let a man be as able and original as he may, he cannot afford to discard knowledge of what has gone before or what is now going on in his own trade and profession. If the printers of today do not wish to be esteemed too arrogant when they term this calling of theirs an art, they must be willing, and show that they are willing, to subject it to such laws as have made its sister arts so free. All those concerned in what are accepted as the fine arts, the learned sciences, and professions surround themselves with the history, literature, and concrete examples of the work with which they are particularly engaged. Yet it is only in rare instances that such an atmosphere, with these material appurtenances, is to be found in the printing office.

abcdefghijklmnopqrstuvwxyz

ABCDEFGHIJKLMNOPQRSTUVWXYZ

\$1234567890

8 Point No. 145J, 8 1/2 Set

### MONOTYPE FACES

The best kind of originality is that which comes after a thorough apprenticeship; that which shall prove to be the blending of a firm conception of all useful precedent and the progressive tendencies of an able mind. For, let a man be as able and original as he may, he cannot afford to discard knowledge of what has gone before or what is now going on in his own trade or his profession. If the printers of today do not wish to be esteemed arrogant when they term this calling of theirs an art, they must be willing, and show that they are willing, to subject it to such laws as have made its sister arts so free. All those concerned in what are accepted as the fine arts, the learned sciences, and professions surround themselves with the history, the literature, and the concrete examples of the work with which they are particularly engaged. Yet it is only in very rare instances that such an atmosphere, with its material appurtenances, is to be found in a printing office. Art does not flourish in hidden places, nor under restraint, nor in ignorance of what talent and genius have accomplished and are accomplishing throughout the world. For to follow precedent wisely does not mean to imitate slavishly one great exemplar,

abcdefghijklmnopqrstuvwxyz

ABCDEFGHIJKLMNOPQRSTUVWXYZ

\$1234567890

12 Point No. 145J, 12 Set

### MONOTYPE FACES

The best kind of originality is that which comes after a sound apprenticeship; that which shall prove to be the blending of a firm conception of all useful precedent and the progressive tendencies of an able mind. For, let a man be as able and original as he may, he cannot afford to discard a knowledge of what has gone before or what is now going on in his own trade and profession. If the printers of today do not wish to be esteemed arrogant when they term this calling of theirs an art, they must be willing, and show that they are willing, to subject it to such laws as have made its sister arts so free. All those who are concerned in what

abcdefghijklmnopqrstuvwxyz

ABCDEFGHIJKLMNOPQRSTUVWXYZ

\$1234567890



14 Point No. 145

**MONOTYPE PROMOTES EXPANSION**  
**Along the Lines of Least Resistance and Greatest Profit to its**  
**Owner. It Produces all the Time**  
**\$1234567890**

18 Point No. 145

**THE BEST PAYING SPECIALTY**  
**Is Quality. Monotype Quality Gets the Work and Insures**  
**a Good Price on the Job**  
**\$1234567890**

24 Point No. 145

**URNS OUT THE WORK**  
**Doesn't Turn Down the Order from Lack**  
**of Proper Facilities**  
**\$1234567890**

30 Point No. 145

**FOREIGN LANGUAGE WORK**  
**Changes from one Language to**  
**Another Made Easily**  
**\$1234567890**

36 Point No. 145

**THE ELASTIC MACHINE**  
**Makes the Face Fit the Space**  
**\$1234567890**

# No. 143J. Book Arrangement C

## Composition Matrices

6 Point No. 143J, 7 Set

### MONOTYPE FACES

The best kind of originality is that which comes after a sound apprenticeship; that which shall prove itself to be the blending of a firm conception of useful precedent and the progressive tendencies of an able mind. For, let a man be as able and original as he may, he cannot afford to discard knowledge of what has gone before or what is now going on in his own trade and profession. If the printers of today do not wish to be esteemed arrogant when they term this calling of theirs an art, they must be willing, and show that they are willing, to subject it to such laws as have made its sister arts so free. All those concerned in what are accepted as the fine arts, the learned sciences, and professions surround themselves with the history, literature, and concrete examples of the work with which they are particularly engaged. Yet it is only in rare instances that such an atmosphere, with its material appurtenances, is to be found in a printing office. Art does not flourish in hidden places, nor under restraint, nor in ignorance of what talent and genius have accomplished and are accomplishing throughout the world. For to follow precedent wisely does not mean to imitate slavishly one great exemplar, but to study all masters faithfully, letting their great achievements sink slowly into the mind in order that we may patiently derive from the richness of our acquired knowledge and organized system an attitude of our own. The sprightly minded young man, who with his first business breath projects the new and startling, inevitably becomes tiresome, and is driven to an early disappearance; while the slower, more solidly endowed student will at least spend as much of his time in avoiding mistakes as in evolving brilliant schemes wherewith to dazzle his contemporaries. The best kind of originality is that which comes after a sound apprenticeship; that which shall prove to be the blending of a firm conception of all useful precedent and the progressive tendencies of an able mind. For, let a man be as able and original as he may, he cannot afford to discard knowledge of what has gone before or what is now going on in his own trade and profession.

abcdefghijklmnopqrstuvwxy

ABCDEFGHIJKLMNOPQRSTUVWXYZ

\$1234567890

10 Point No. 143J, 10 Set

### MONOTYPE FACES

The best kind of originality is that which comes after a sound apprenticeship; that which shall prove to be the blending of a firm conception of all useful precedent and the progressive tendencies of an able mind. For, let a man be as able and original as he may, he cannot afford to discard knowledge of what has gone before or what is now going on in his own trade and profession. If the printers of today do not wish to be esteemed too arrogant when they term this calling of theirs an art, they must be willing, and show that they are willing, to subject it to such laws as have made its sister arts so free. All those concerned in what are accepted as the fine arts, the learned sciences and the professions, surround themselves with the history, literature, and concrete examples of the work with which they are particularly engaged. Yet it is only in rare instances that such an atmosphere, with its material appurtenances, is to be found in the printing office. Art does not flourish in hidden places, nor under restraint, nor in ignorance of

abcdefghijklmnopqrstuvwxy

ABCDEFGHIJKLMNOPQRSTUVWXYZ

\$1234567890

8 Point No. 143J, 8 1/2 Set

### MONOTYPE FACES

The best kind of originality is that which comes after a sound apprenticeship; that which shall prove to be the blending of a firm conception of all useful precedent and the progressive tendencies of an able mind. For, let a man be as able and original as he may, he cannot afford to discard knowledge of what has gone before or what is now going on in his own trade and profession. If the printers of today do not wish to be esteemed arrogant when they term this calling of theirs an art, they must be willing, and show that they are willing, to subject it to such laws as have made its sister arts so free. All those concerned in what are accepted as the fine arts, the learned sciences, and the professions surround themselves with the history, the literature, and concrete examples of the work with which they may be particularly engaged. Yet it is only in rare instances that such an atmosphere, with its material appurtenances, is to be found in a printing office. Art does not flourish in hidden places, nor under restraint, nor in ignorance of what talent and genius have accomplished and are now accomplishing throughout the world. For to follow precedent wisely does not mean to imitate slavishly one great exemplar, but to study all the masters faithfully, letting their greatest achievements sink slowly into the mind in order that we may patiently derive from

abcdefghijklmnopqrstuvwxy

ABCDEFGHIJKLMNOPQRSTUVWXYZ

\$1234567890

12 Point No. 143J, 12 Set

### MONOTYPE FACES

The best kind of originality is that which comes after a sound apprenticeship; that which shall prove to be the blending of a firm conception of all useful precedent and the progressive tendencies of an able mind. For, let any man be as able and original as he may, he cannot afford to discard knowledge of what has gone before or what is now going on in his own trade and profession. If the printers of today do not wish to be esteemed arrogant when they term this calling of theirs an art, they must be willing, and also show that they are willing, to subject it to such laws as have made its sister arts so free. All those concerned in what are accepted as the fine arts, and the learned sciences and professions surround themselves with

abcdefghijklmnopqrstuvwxy

ABCDEFGHIJKLMNOPQRSTUVWXYZ

\$1234567890

14 Point No. 143

**ALL MATTER IS STRAIGHT MATTER**

**Tariff, Tabular and Intricate Catalogue Composition Handled like  
Straight Matter on the Monotype**

**\$1234567890**

18 Point No. 143

**GET A TYPE CASTER**

**Convert it into a Composing Machine for Casting all  
Kinds of Justified Ready-to-print Matter**

**\$1234567890**

24 Point No. 143

**THE ONLY MACHINE**

**Having a Complete and Varied Assortment  
of its own Matrices**

**\$1234567890**

30 Point No. 143

**A MATRIX LIBRARY**

**All Faces Leased to Customers, just  
like a Circulating Library**

**\$1234567890**

36 Point No. 143

**BUY A MACHINE**

**With a Repeat-order Record**

**\$1234567890**

# No. 153J. Job Arrangement C2

## Composition Matrices

6 Point No. 153J, 7 Set

### MONOTYPE FACES

The best kind of originality is that which comes after a sound apprenticeship; that which shall prove to be the blending of a firm conception of all useful precedent and the progressive tendencies of an able mind. For, let a man be as able and original as he may, he cannot afford to discard knowledge of what has gone before or what is now going on in his own trade and profession. If the printers of today do not wish to be esteemed arrogant when they term this calling of theirs an art, they must be willing, and show that they are willing, to subject it to such laws as have made its sister arts so free. All those concerned in what are accepted as the fine arts, the learned sciences, and professions surround themselves with the history, the literature, and concrete examples of the work with which they are particularly engaged. Yet it is only in very rare instances that such an atmosphere, with its material appurtenances, is to be found in a printing office. Art does not flourish in hidden places, nor under restraint, nor in ignorance of what talent and genius have accomplished and are accomplishing throughout the world. For to follow precedent wisely does not mean to imitate too slavishly one great exemplar, but to study all masters faithfully, letting their great achievements sink slowly into the mind in order that we may patiently derive from the richness of our acquired knowledge and organized system an attitude of our own. The sprightly minded young man, who with his first business breath projects the new and startling, inevitably becomes tiresome, and is driven to an early disappearance; while the slower, more solidly endowed student will at least spend as much of his time in avoiding mistakes as in evolving brilliant schemes wherewith to dazzle his contemporaries. The best kind of originality is that which comes after a sound apprenticeship; that which shall prove to

abdefghijklmnopqrstuvwxyz  
 ABCDEFGHIJKLMNOPQRSTUVWXYZ  
 \$1234567890

7 Point No. 153J, 8 Set

### MONOTYPE FACES

The best kind of originality is that which comes after a sound apprenticeship; that which shall prove to be the blending of a firm conception of all useful precedent and the progressive tendencies of an able mind. For, let a man be as able and original as he may, he cannot afford to discard knowledge of what has gone before or what is now going on in his own trade and profession. If the printers of today do not wish to be esteemed arrogant when they term this calling of theirs an art, they must be willing, and show that they are willing, to subject it to such laws as have made its sister arts so free. All those concerned in what are accepted as the fine arts, the learned sciences, and professions surround themselves with the history, the literature, and concrete examples of the work with which they are particularly engaged. Yet it is only in very rare instances that such an atmosphere, with its material appurtenances, is to be found in a printing office. Art does not flourish in hidden places, nor under restraint, nor in ignorance of what talent and genius have accomplished and are accomplishing throughout the world. For to follow precedent wisely does not mean to imitate too slavishly one great exemplar, but to study all masters faithfully, letting their great achievements sink slowly into the mind in order that we may patiently derive from the richness of our acquired knowledge and organized system an attitude of our own. The sprightly minded

abdefghijklmnopqrstuvwxyz  
 ABCDEFGHIJKLMNOPQRSTUVWXYZ  
 \$1234567890

8 Point No. 153J, 8½ Set

### MONOTYPE FACES

The very best kind of originality is that which comes after a thorough apprenticeship; that which shall prove to be the blending of a firm conception of all useful precedent and the progressive tendencies of an able mind. For, let a man be as able and original as he may, he cannot afford to discard knowledge of what has gone before or what is now going on in his own trade and profession. If the printers of today do not wish to be esteemed arrogant when they term this calling of theirs an art, they must be willing, and show that they are willing, to subject it to such laws as have made its sister arts so free. All those concerned in what are accepted as the fine arts, the learned sciences, and professions surround themselves with the history, the literature, and the concrete examples of the work with which they are particularly engaged. Yet it is only in very rare instances that such an atmosphere, with its material appurtenances, is to be found in a printing office. Art does not flourish in the hidden places, nor under restraint, nor in ignorance of what talent and genius have accomplished and are accomplishing throughout the world. For to follow precedent wisely does not mean to imitate slavishly one great exemplar,

abdefghijklmnopqrstuvwxyz  
 ABCDEFGHIJKLMNOPQRSTUVWXYZ  
 \$1234567890

### MONOTYPE FACES

The very best kind of originality is that which comes after a thorough apprenticeship; that which shall prove to be the blending of a firm conception of all useful precedent and the progressive tendencies of an able mind. For, let a man be as able and original as he may, he cannot afford to discard knowledge of what has gone before or what is now going on in his own trade and profession. If the printers of today do not wish to be esteemed arrogant when they term this calling of theirs an art, they must be willing, and show that they are willing, to subject it to such laws as have made its sister arts so free. All those concerned in what are accepted as the fine arts, the learned sciences, and professions surround themselves with the history, the literature, and the concrete examples of the work with which they are particularly engaged. Yet it is only in very rare instances that such an atmosphere, with its material appurtenances, is to be found in a printing office. Art does not flourish in the hidden places, nor under restraint, nor in ignorance of what talent and genius have accomplished and are accomplishing throughout the world. For to follow precedent wisely does not mean to imitate slavishly one great exemplar, but to study all masters faithfully, letting their great achievements sink slowly into the mind in order that we may patiently derive from the richness of all our acquired knowledge and organized system an attitude of our own. The sprightly minded young man, who with his first business breath projects the

# No. 159J. Job Arrangement C2

## Composition Matrices

6 Point No. 159J, 7 Set

### MONOTYPE FACES

The best kind of originality is that which comes after a sound apprenticeship; that which shall prove to be the blending of a firm conception of all useful precedent and the progressive tendencies of an able mind. For, let a man be as able and original as he may, he cannot afford to discard knowledge of what has gone before or what is now going on in his own trade or his profession. If the printers of today do not wish to be esteemed arrogant when they term this calling of theirs an art, they must be willing, and show that they are willing, to subject it to such laws as have made its sister arts so free. All those concerned in what are accepted as the fine arts, the learned sciences, and professions surround themselves with the history, the literature, and concrete examples of the work with which they are particularly engaged. Yet it is only in very rare instances that such an atmosphere, with its material appurtenances, is to be found in a printing office. Art does not flourish in hidden places, nor under restraint, nor in ignorance of what talent and genius have accomplished and are accomplishing throughout the world. For to follow all precedent wisely does not mean to imitate too slavishly one great exemplar, but to study all masters faithfully, letting their great achievements sink slowly into the mind in order that we may patiently derive from the richness of our acquired knowledge and organized system an attitude of our own. The sprightly minded young man, who with his first business breath projects the new and startling, inevitably becomes tiresome, and is driven to an early disappearance; while the slower, more solidly endowed student will at least spend as much of his time in avoiding mistakes as in evolving brilliant schemes wherewith to dazzle his contemporaries. The best kind of originality is that which comes after a sound apprenticeship; that which shall prove to

abcdefghijklmnopqrstuvwxy  
ABCDEFGHIJKLMNOPQRSTUVWXYZ  
\$1234567890

8 Point No. 159J, 8½ Set

### MONOTYPE FACES

The best kind of originality is that which comes after a thorough apprenticeship; that which shall prove to be the blending of a firm conception of all useful precedent and the progressive tendencies of an able mind. For, let a man be as able and original as he may, he cannot afford to discard knowledge of what has gone before or what is now going on in his own trade or his profession. If the printers of today do not wish to be esteemed too arrogant when they term this calling of theirs an art, they must be willing, and show that they are willing, to subject it to such laws as have made its sister arts so free. All those concerned in what are accepted as the fine arts, the learned sciences, and professions surround themselves with the history, the literature, and the concrete examples of the work with which they are particularly engaged. Yet it is only in very rare instances that such an atmosphere, with its material appurtenances, is to be found in a printing office. Art does not flourish in hidden places, nor under restraint, nor in ignorance of what talent and genius have accomplished, and are accomplishing throughout the world. For to follow precedent wisely does not mean to imitate slavishly one great exemplar,

abcdefghijklmnopqrstuvwxy  
ABCDEFGHIJKLMNOPQRSTUVWXYZ  
\$1234567890

10 Point No. 159J, 10½ Set

### MONOTYPE FACES

The best kind of originality is that which comes after a sound apprenticeship; that which shall prove to be the blending of a firm conception of all useful precedent and the progressive tendencies of an able mind. For, let a man be as able and original as he may, he cannot afford to discard knowledge of what has gone before or what is now going on in his own trade and profession. If the printers of today do not wish to be esteemed too arrogant when they term this calling of theirs an art, they must be willing, and show that they are willing, to subject it to just such laws as have made its sister arts so free. All those concerned in what are accepted as the fine arts, the learned sciences, and professions surround themselves with the history, literature, and concrete examples of the work with which they are particularly engaged. Yet it is only in very rare instances that such an atmosphere, with

abcdefghijklmnopqrstuvwxy  
ABCDEFGHIJKLMNOPQRSTUVWXYZ  
\$1234567890

12 Point No. 159J, 12 Set

### MONOTYPE FACES

The best kind of originality is that which comes after a sound apprenticeship; that which shall prove to be the blending of a firm conception of all useful precedent and the progressive tendencies of an able mind. For, let a man be as able and original as he may, he cannot afford to discard knowledge of what has gone before or what is now going on in his own trade and profession. If the printers of today do not wish to be esteemed arrogant when they term this calling of theirs an art, they must be willing, and show that they are willing, to subject it to such laws as have made its sister arts so free. All those who are concerned in what

abcdefghijklmnopqrstuvwxy  
ABCDEFGHIJKLMNOPQRSTUVWXYZ  
\$1234567890

Composition Matrices

6 Point No. 163J, 7 Set

**MONOTYPE FACES**

The best kind of originality is that which comes after a sound apprenticeship; that which shall prove to be the blending of a firm conception of all useful precedent and the progressive tendencies of an able mind. For, let a man be as able and original as he may, he cannot afford to discard knowledge of what has gone before or what is now going on in his own trade and profession. If the printers of today do not wish to be esteemed arrogant when they term this calling of theirs an art, they must be willing, and show that they are willing, to subject it to such laws as have made its sister arts so free. All those concerned in what are accepted as the fine arts, the learned sciences, and professions surround themselves with the history, literature, and the concrete examples of the work with which they are particularly engaged. Yet it is only in very rare instances that this atmosphere, with its material appurtenances, is to be found in a printing office. Art does not flourish in hidden places, nor under restraint, nor in ignorance of what talent and genius have accomplished and are accomplishing throughout the world. For to follow precedent wisely does not mean to imitate slavishly one great exemplar, but to study all masters faithfully, letting their great achievements sink slowly into the mind in order that we may patiently derive from the richness of our acquired knowledge and organized system an attitude of our own. The sprightly minded young man, who with his first business breath projects the new and startling, inevitably becomes tiresome, and is driven to an early disappearance; while the slower, more solidly endowed student will at least spend as much of his time in avoiding mistakes as in evolving brilliant schemes wherewith to dazzle his contemporaries. The best kind of originality is that which comes after a sound apprenticeship; that which shall prove to

abcdefghijklmnopqrstuvwxy

ABCDEFGHIJKLMN O P Q R S T U V W X Y Z

\$1234567890

10 Point No. 163J, 10 Set

**MONOTYPE FACES**

The best kind of originality is that which comes after a sound apprenticeship; that which shall prove to be the blending of a firm conception of all useful precedent and the progressive tendencies of an able mind. For, let a man be as able and original as he may, he cannot afford to discard knowledge of what has gone before or what is now going on in his own trade and profession. If the printers of today do not wish to be esteemed too arrogant when they term this calling of theirs an art, they must be willing, and show that they are willing, to subject it to such laws as have made its sister arts so free. All those concerned in what are accepted as the fine arts, the learned sciences, and professions surround themselves with the history, literature, and concrete examples of the work with which they are particularly engaged. Yet it is only in rare instances that such an atmosphere, with these material appurtenances, is to be found in a printing office.

abcdefghijklmnopqrstuvwxy

ABCDEFGHIJKLMN O P Q R S T U V W X Y Z

\$1234567890

8 Point No. 163J, 8 1/2 Set

**MONOTYPE FACES**

The best kind of originality is that which comes after a sound apprenticeship; that which shall prove to be the blending of a firm conception of all useful precedent and the progressive tendencies of an able mind. For, let a man be as able and original as he may, he cannot afford to discard knowledge of what has gone before or what is now going on in his own trade and profession. If the printers of today do not wish to be esteemed arrogant when they term this calling of theirs an art, they must be willing, and show that they are willing, to subject it to such laws as have made its sister arts so free. All those concerned in what are accepted as the fine arts, the learned sciences, and professions surround themselves with the history, literature, and concrete examples of the work with which they are particularly engaged. Yet it is only in rare instances that such an atmosphere, with its material appurtenances, is to be found in a printing office. Art does not flourish in hidden places, nor under restraint, nor in ignorance of what talent and genius have accomplished and are accomplishing throughout the world. For to follow precedent wisely does not mean to imitate slavishly one great exemplar,

abcdefghijklmnopqrstuvwxy

ABCDEFGHIJKLMN O P Q R S T U V W X Y Z

\$1234567890

12 Point No. 163J, 12 Set

**MONOTYPE FACES**

The best kind of originality is that which comes after a sound apprenticeship; that which shall prove to be the blending of a firm conception of all useful precedent and the progressive tendencies of an able mind. For, let a man be as able and original as he may, he cannot afford to discard a knowledge of what has gone before or what is now going on in his own trade and profession. If the printers of today do not wish to be esteemed arrogant when they term this calling of theirs an art, they must be willing, and show that they are willing, to subject it to such laws as have made its sister arts so free. All those who are concerned in what

abcdefghijklmnopqrstuvwxy

ABCDEFGHIJKLMN O P Q R S T U V W

\$1234567890

14 Point No. 163

**MONOTYPE TYPE IS GOOD TYPE**  
**No Foundry Type Made is More Solid or Has a Better Face than**  
**Type Cast on the Monotype**  
**\$1234567890**

18 Point No. 163

**THE BUSINESS BUILDER**  
**The Monotype is all the Time on Live Copy, and**  
**Taking the Work as it Comes**  
**\$1234567890**

24 Point No. 163

**ALWAYS READY**  
**To Handle the Regular and the Rush**  
**Job in the Shortest Time**  
**\$1234567890**

30 Point No. 163

**THE BEST WAY**  
**To Answer the Sorts Problem is**  
**to Monotype it**  
**\$1234567890**

36 Point No. 163

**AT EVERY POINT**  
**A Monotype is on the Job**  
**\$1234567890**

# No. 173E. Book Arrangement C

## Composition Matrices

6 Point No. 173E, 7 Set

### MONOTYPE FACES

The best kind of originality is that which comes after a sound apprenticeship; that which shall prove itself to be the blending of a firm conception of useful precedent and the progressive tendencies of an able mind. For, let a man be as able and original as he may, he cannot afford to discard knowledge of what has gone before or what is now going on in his own trade and profession. If the printers of today do not wish to be esteemed arrogant when they term this calling of theirs an art, they must be willing, and show that they are willing, to subject it to such laws as have made its sister arts so free. All those concerned in what are accepted as the fine arts, the learned sciences, and professions surround themselves with the history, the literature, and concrete examples of work with which they are particularly engaged. Yet it is only in very rare instances that such an atmosphere, with its material appurtenances, is to be found in the printing office. Art does not flourish in hidden places, nor under restraint, nor in ignorance of what talent and genius have accomplished and are accomplishing throughout the world. For to follow precedent wisely does not mean to imitate slavishly one great exemplar, but to study all the masters faithfully, letting their great achievements sink slowly into the mind in order that we may patiently derive from the richness of our acquired knowledge and organized system an attitude of our own. The sprightly minded young man, who with his first business breath projects the new and startling, inevitably becomes tiresome, and is driven to an early disappearance; while the slower and more solidly endowed student will at least spend as much of his time in avoiding mistakes as in evolving brilliant schemes wherewith to dazzle his contemporaries. The best kind of originality is that which comes after a sound apprenticeship; that which shall prove itself to be the blending of a firm conception of all useful precedent and the progressive tendencies of an able mind. For, let any man be as able and original as he may, he cannot afford to discard knowledge of what has gone before or what is now going on in his own trade and profession. If the printers

abcdefghijklmnopqrstuvwxy  
ABCDEFGHIJKLMNOPQRSTUVWXYZ  
\$1234567890

10 Point No. 173E, 10 Set

### MONOTYPE FACES

The best kind of originality is that which comes after a sound apprenticeship; that which shall prove to be the blending of a firm conception of all useful precedent and the progressive tendencies of an able mind. For, let a man be as able and original as he may, he cannot afford to discard knowledge of what has gone before or what is now going on in his own trade and profession. If the printers of today do not wish to be esteemed arrogant when they term this calling of theirs an art, they must be willing, and show that they are willing, to subject it to such laws as have made its sister arts so free. All those concerned in what are accepted as the fine arts, the learned sciences, and the professions surround themselves with the history, the literature, and concrete examples of the work with which they are particularly engaged. Yet it is only in very rare instances that such an atmosphere, with all its material appurtenances, is to be found in the printing office. Art does not flourish in hidden places, nor under restraint, nor in ignorance of what talent

abcdefghijklmnopqrstuvwxy  
ABCDEFGHIJKLMNOPQRSTUVWXYZ  
\$1234567890

8 Point No. 173E, 8½ Set

### MONOTYPE FACES

The best kind of originality is that which comes after a sound apprenticeship; that which shall prove to be the blending of a firm conception of all useful precedent and the progressive tendencies of an able mind. For, let a man be as able and original as he may, he cannot afford to discard knowledge of what has gone before or what is now going on in his own trade or his profession. If the printers of today do not wish to be esteemed arrogant when they term this calling of theirs an art, they must be willing, and show that they are willing, to subject it to such laws as have made its sister arts so free. All those concerned in what are accepted as the fine arts, the learned sciences, and the professions surround themselves with the history, the literature, and concrete examples of the work with which they are particularly engaged. Yet it is only in very rare instances that such an atmosphere, with its material appurtenances, is to be found in a printing office. Art does not flourish in hidden places, nor under restraint, nor in ignorance of what talent and genius have accomplished and are now accomplishing throughout the world. For to follow precedent wisely does not mean to imitate slavishly one great exemplar, but to study all the masters faithfully, letting their great achievements sink slowly into the mind in order that we may patiently derive from the

abcdefghijklmnopqrstuvwxy  
ABCDEFGHIJKLMNOPQRSTUVWXYZ  
\$1234567890

12 Point No. 173E, 12 Set

### MONOTYPE FACES

The best kind of originality is that which comes after a sound apprenticeship; that which shall prove to be the blending of a firm conception of all useful precedent and the progressive tendencies of an able mind. For, let any man be as able and original as he may, he cannot afford to discard knowledge of what has gone before or what is now going on in his own trade and profession. If the printers of today do not wish to be esteemed arrogant when they term this calling of theirs an art, they must be willing, and show that they are willing, to subject it to such laws as have made its sister arts so free. All those concerned in what are accepted as the fine arts, the learned sciences, and professions surround themselves with the

abcdefghijklmnopqrstuvwxy  
ABCDEFGHIJKLMNOPQRSTUVWXYZ  
\$1234567890



# No. 189J. Job Arrangement C2

## Composition Matrices

12 Point No. 189J, 12½ Set

### MONOTYPE FACES

The best kind of originality is that which comes after a sound apprenticeship; that which shall prove to be the blending of a firm conception of all useful precedent and the progressive tendencies of an able mind. For, let a man be as able and original as he may, he cannot afford to discard knowledge of what has gone before or what is now going on in his own trade and profession. If the printers of today do not wish to be esteemed too arrogant when they term this calling of theirs an art, they must be willing, and show that they are willing, to subject it to such

### MONOTYPE FACES

The best kind of originality is that which comes after a sound apprenticeship; that which shall prove to be the blending of a firm conception of all useful precedent and the progressive tendencies of an able mind. For, let a man be as able and original as he may, he cannot afford to discard knowledge of what has gone before or what is now going on in his own trade and profession. If the printers of today do not wish to be esteemed too arrogant when they term this calling of theirs an art, they must be willing, and show that they are willing, to subject it to such laws as have made its sister arts so free. All those concerned in what

abcdefghijklmnopqrstuvwxyz

ABCDEFGHIJKLMNOPQRSTUVWXYZ

\$1234567890

14 Point No. 189

**SELECT A GOOD FACE**

**Type Can Suggest, Not Merely by the Words It Spells, but  
by the Appearance of the Type Itself**

**\$1234567890**

18 Point No. 189

**THE MONOTYPE**

**Will Show You How Good Type Can Do the  
Most Effective Work**

**\$1234567890**

24 Point No. 189

**CRITICAL ADVERTISERS**

**Invariably Insist on Getting Monotype  
Composition**

**\$1234567890**

91

# No. 220J. Job Arrangement C2

## Composition Matrices

10 Point No. 220J, 10 Set

### MONOTYPE FACES

The best kind of originality is that which comes after a thorough apprenticeship; that which shall prove to be the blending of a firm conception of all useful precedent and the progressive tendencies of an able mind. For, let a man be as able and original as he may, he cannot afford to discard knowledge of what has gone before or what is now going on in his own trade and profession. If the printers of today do not wish to be esteemed too arrogant when they term this calling of theirs an art, they must be willing, and show that they are willing, to subject it to such laws as have made its sister arts so free. All those concerned in what are accepted as the fine arts, the learned sciences, and professions surround themselves with the history, literature, and concrete examples of the work

abcdefghijklmnopqrstuvwxy  
ABCDEFGHIJKLMNOPQRSTUVWXYZ  
\$1234567890

### MONOTYPE FACES

The best kind of originality is that which comes after a thorough apprenticeship; that which shall prove to be the blending of a firm conception of all useful precedent and the progressive tendencies of an able mind. For, let a man be as able and original as he may, he cannot afford to discard knowledge of what has gone before or what is now going on in his own trade and profession. If the printers of today do not wish to be esteemed too arrogant when they term this calling of theirs an art, they must be willing, and show that they are willing, to subject it to such laws as have made its sister arts so free. All those concerned in what are accepted as the fine arts, the learned sciences, and professions surround themselves with the history, literature, and concrete examples of the work with which they are particularly engaged. Yet it is only in rare instances that such an atmosphere, with these material appurte-

12 Point No. 220J, 12 Set

### MONOTYPE FACES

The best kind of originality is that which comes after a sound apprenticeship; that which shall prove to be the blending of a firm conception of all useful precedent and the progressive tendencies of an able mind. For, let a man be as able and original as he may, he cannot afford to discard a knowledge of what has gone before or what is now going on in his own trade and profession. If the printers of today do not wish to be esteemed arrogant when they term this calling of theirs an art, they must be willing, and show that they are willing, to subject it to such laws

abcdefghijklmnopqrstuvwxy  
ABCDEFGHIJKLMNOPQRSTUVW  
\$1234567890

### MONOTYPE FACES

The best kind of originality is that which comes after a sound apprenticeship; that which shall prove to be the blending of a firm conception of all useful precedent and the progressive tendencies of an able mind. For, let a man be as able and original as he may, he cannot afford to discard a knowledge of what has gone before or what is now going on in his own trade and profession. If the printers of today do not wish to be esteemed arrogant when they term this calling of theirs an art, they must be willing, and show that they are willing, to subject it to such laws as have made its sister arts so free. All those who are concerned in what

14 Point No. 220

**OUR TYPE-&-RULE CASTER**

Makes the contents of the Hell Box into new type, spaces,  
borders, rules, leads and slugs

**\$1234567890**

18 Point No. 220

**FURNISH THE TOOLS**

Your Compositors Need to Work Efficiently—type,  
rules, leads, slugs and space material

**\$1234567890**

24 Point No. 220

**NON-DISTRIBUTION**

It costs less to make new type than to  
distribute used type

**\$1234567890**

30 Point No. 220

**MONOTYPE PRODUCT**

High Quality and Low Hour Cost  
go hand in hand

**\$1234567890**

36 Point No. 220

**GOOD WORK**

Monotype type and rule

**\$1234567890**

# No. 360J. Job Arrangement C4

## Composition Matrices

12 Point No. 360J, 12½ Set

### MONOTYPE FACES

The very best kind of originality is that which comes after a sound apprenticeship; that which shall prove to be the blending of a firm conception of all useful precedent and the progressive tendencies of an able mind. For, let a man be as able and original as he may, he cannot afford to discard knowledge of what has gone before or what is now going on in his own trade and profession. If the good printers of today do not wish to be esteemed too arrogant when they term this calling of theirs an art, they must be willing, and show that they are willing, to subject it to such laws as have made its sister arts so free. All those concerned in what are

### MONOTYPE FACES

The very best kind of originality is that which comes after a sound apprenticeship; that which shall prove to be the blending of a firm conception of all useful precedent and the progressive tendencies of an able mind. For, let a man be as able and original as he may, he cannot afford to discard knowledge of what has gone before or what is now going on in his own trade and profession. If the good printers of today do not wish to be esteemed too arrogant when they term this calling of theirs an art, they must be willing, and show that they are willing, to subject it to such laws as have made its sister arts so free. All those concerned in what are accepted as the fine arts, the learned sciences and the professions, surround themselves with the history, the litera-

abcdefghijklmnopqrstuvwxyz

ABCDEFGHIJKLMNOPQRSTUVWXYZ

\$1234567890

14 Point No. 360

**THE MONOTYPE COMPOSING MACHINE**

**Sets all kinds of Matter, Plain or Intricate, in any Measure up to  
60 Picas, in all sizes from 5 to 18 Point  
\$1234567890**

18 Point No. 360

**A COMPLETE MONOTYPE**

**Is much more than a Composing Machine; it furnishes  
all the Equipment used by Hand Compositors  
\$1234567890**

24 Point No. 360

**THE MONOTYPE PRINTER**

**Who Casts his own Material makes Large  
Savings in Time and Money  
\$1234567890**

30 Point No. 360

**RAISING THE STANDARD  
of Workmanship throughout the Plant  
is Easy with the Monotype  
\$1234567890**

36 Point No. 360

**A GOOD START  
is a Step in the Right Direction  
\$1234567890**

# No. 11J. Job Arrangement C2

## Composition Matrices

5 Point No. 11J, 6 Set

### MONOTYPE FACES

The best kind of originality is that which comes after a sound apprenticeship; that which shall prove to be the blending of a firm conception of all useful precedent and the progressive tendencies of an able mind. For, let a man be as able and original as he may, he cannot afford to discard knowledge of what has gone before or what is now going on in his own trade and profession. If the printers of today do not wish to be esteemed arrogant when they term this calling of theirs an art, they must be willing, and show that they are willing, to subject it to such laws as have made its sister arts so free. All those concerned in what are accepted as the fine arts, the learned sciences, and professions surround themselves with the history, literature, and concrete examples of the work with which they are particularly engaged. Yet it is only in rare instances that such an atmosphere, with its material appurtenances, is to be found in a printing office. Art does not flourish in hidden places, nor under restraint, nor even in ignorance of what talent and genius have accomplished and are accomplishing throughout the world. For to follow precedent wisely does not mean to imitate slavishly one great exemplar, but to study all masters faithfully, letting their great achievements sink slowly into the mind in order that we may patiently derive from the richness of our acquired knowledge and organized system an attitude of our own. The sprightly minded young man, who with his first business breath projects the new and startling, inevitably becomes tiresome, and is driven to an early disappearance; while the slower, more solidly endowed student will at least spend as much of his time in avoiding mistakes as in evolving brilliant schemes wherewith to dazzle his contemporaries. The best kind of originality is that which comes after a sound apprenticeship; that which shall prove to be the blending of a firm conception of all useful precedent and the progressive tendencies of an able mind. For, let a man be as able and original as he may, he cannot afford to discard knowledge of what has gone before or what is now going on in his own trade and profession. If the printers of today do not wish to be esteemed arrogant when they term this calling of theirs an art, they must be willing, and show that they are willing, to subject it to such laws as have made its sister arts so free. All those concerned in what are accepted as the fine arts, the learned sciences, and the professions surround themselves with the history, literature, and concrete examples of the work with which they are particularly engaged. Yet it is only in rare instances that such an atmosphere, with its material

abcdefghijklmnopqrstuvwxyz  
 ABCDEFGHIJKLMNOPQRSTUVWXYZ  
 51234567890

8 Point No. 11J, 8 1/2 Set

### MONOTYPE FACES

The very best kind of originality is that which comes after a thorough apprenticeship; that which shall prove to be the blending of a firm conception of all useful precedent and the progressive tendencies of an able mind. For, let a man be as able and original as he may, he cannot afford to discard knowledge of what has gone before or what is now going on in his own trade and profession. If the printers of today do not wish to be esteemed arrogant when they term this calling of theirs an art, they must be willing, and show that they are willing, to subject it to such laws as have made its sister arts so free. All those concerned in what are accepted as the fine arts, the learned sciences, and professions surround themselves with the history, the literature, and the concrete examples of the work with which they are particularly engaged. Yet it is only in very rare instances that such an atmosphere, with its material appurtenances, is to be found in a printing office. Art does not flourish in hidden places, nor under restraint, nor in ignorance of what talent and genius have accomplished and are accomplishing throughout the world. For to follow precedent wisely does not mean to imitate slavishly one great exemplar, but to study all the masters faithfully, letting their greatest achievements sink slowly into the mind in order that we may patiently derive from the richness

abcdefghijklmnopqrstuvwxyz  
 ABCDEFGHIJKLMNOPQRSTUVWXYZ  
 51234567890

6 Point No. 11J, 7 Set

### MONOTYPE FACES

The best kind of originality is that which comes after a sound apprenticeship; that which shall prove to be the blending of a firm conception of all useful precedent and the progressive tendencies of an able mind. For, let a man be as able and original as he may, he cannot afford to discard knowledge of what has gone before or what is now going on in his own trade and profession. If the printers of today do not wish to be esteemed arrogant when they term this calling of theirs an art, they must be willing, and show that they are willing, to subject it to such laws as have made its sister arts so free. All those concerned in what are accepted as the fine arts, the learned sciences, and professions surround themselves with the history, literature, and concrete examples of the work with which they are particularly engaged. Yet it is only in very rare instances that such an atmosphere, with its material appurtenances, is to be found in a printing office. Art does not flourish in hidden places, nor under restraint, nor in ignorance of what talent and genius have accomplished and are accomplishing throughout the world. For to follow all precedent wisely does not mean to imitate too slavishly one great exemplar, but to study all masters faithfully, letting their great achievements sink slowly into the mind in order that we may patiently derive from the richness of our acquired knowledge and organized system an attitude of our own. The sprightly minded young man, who with his first business breath projects the new and startling, inevitably becomes tiresome, and is driven to an early disappearance; while the slower, more solidly endowed student will at least spend as much of his time in avoiding mistakes as in evolving brilliant schemes wherewith to dazzle his contemporaries. The best kind of originality is that which comes after a sound apprenticeship; that which shall prove to

abcdefghijklmnopqrstuvwxyz  
 ABCDEFGHIJKLMNOPQRSTUVWXYZ  
 51234567890

10 Point No. 11J, 10 Set

### MONOTYPE FACES

The best kind of originality is that which comes after a sound apprenticeship; that which shall prove to be the blending of a firm conception of all useful precedent and the progressive tendencies of an able mind. For, let any man be as able and original as he may, he cannot afford to discard knowledge of what has gone before or what is now going on in his own trade and profession. If the printers of today do not wish to be esteemed too arrogant when they term this calling of theirs an art, they must be willing, and show that they are willing, to subject it to just such laws as have made its sister arts so free. All those concerned in what are accepted as the fine arts, the learned sciences, and professions surround themselves with the history, literature, and concrete examples of the work with which they are particularly engaged. Yet it is only in very rare instances that such an atmosphere, with

abcdefghijklmnopqrstuvwxyz  
 ABCDEFGHIJKLMNOPQRSTUVWXYZ  
 51234567890

## No. 11J. Job Arrangement C2

### Composition Matrices

11 Point No. 11J, 11 Set

#### MONOTYPE FACES

The very best kind of originality is that which comes after a sound apprenticeship; that which shall prove itself to be the blending of a firm conception of all useful precedent and the progressive tendencies of an able mind. Let any man be as able and original as he may, he cannot afford to discard knowledge of what has gone before or what is now going on in his own trade and profession. If the printers of today do not wish to be esteemed arrogant when they term this calling of theirs an art, they must be willing, and show that they are willing, to subject it to such laws as have

abcdefghijklmnopqrstuvwxyz  
ABCDEFGHIJKLMNQPQRSTUVWXYZ  
\$1234567890

#### MONOTYPE FACES

The very best kind of originality is that which comes after a sound apprenticeship; that which shall prove itself to be the blending of a firm conception of all useful precedent and the progressive tendencies of an able mind. Let any man be as able and original as he may, he cannot afford to discard knowledge of what has gone before or what is now going on in his own trade and profession. If the printers of today do not wish to be esteemed arrogant when they term this calling of theirs an art, they must be willing, and show that they are willing, to subject it to such laws as have made its sister arts so free. All those concerned in what are accepted as the

12 Point No. 11J, 12 Set

#### MONOTYPE FACES

The best kind of originality is that which comes after a sound apprenticeship; that which shall prove to be the blending of a firm conception of all useful precedent and the progressive tendencies of an able mind. For, let a man be as able and original as he may, he cannot afford to discard a knowledge of what has gone before or what is now going on in his own trade and profession. If the printers of today do not wish to be esteemed arrogant when they term this calling of theirs an art, they must be willing, and show that they are willing, to subject it to such laws as have made its sister arts so free.

abcdefghijklmnopqrstuvwxyz  
ABCDEFGHIJKLMNQPQRSTUVWXYZ  
\$1234567890

#### MONOTYPE FACES

The best kind of originality is that which comes after a sound apprenticeship; that which shall prove to be the blending of a firm conception of all useful precedent and the progressive tendencies of an able mind. For, let a man be as able and original as he may, he cannot afford to discard a knowledge of what has gone before or what is now going on in his own trade and profession. If the printers of today do not wish to be esteemed arrogant when they term this calling of theirs an art, they must be willing, and show that they are willing, to subject it to such laws as have made its sister arts so free. All those who are concerned in what are now accepted as the fine arts,



14 Point No. 11

**FIGURE THE COST**

**Of the Machines and Accessories Offered to do Approximately  
what any Monotype will do**

**\$1234567890**

18 Point No. 11

**THE TYPEWRITER KEYBOARD**

**Easy to Learn, Easy to Operate, just the same as  
the Standard Typewriter**

**\$1234567890**

24 Point No. 11

**QUICK CHANGE**

**Of Measure and Mold Keeps up Product  
and Keeps down Cost**

**\$1234567890**

30 Point No. 11

**HIGH OR LOW SPACES**

**Produced by the Monotype at  
the Will of the Operator**

**\$1234567890**

36 Point No. 11

**OUR TYPE CASTER**

**A Complete Type Foundry**

**\$1234567890**

No. 11K. Job Arrangement C2

Composition Matrices

8 Point No. 11K, 8½ Set

MONOTYPE FACES

The best kind of originality is that which comes after a sound apprenticeship; that which shall prove to be the blending of a firm conception of all useful precedent and the progressive tendencies of an able mind. For, let any man be as able and original as he may, he cannot afford to discard knowledge of what has gone before or what is now going on in his own trade and profession. If the printers of today do not wish to be esteemed too arrogant when they term this calling of theirs an art, they must be willing, and show that they are willing, to subject it to such laws as have made its sister arts so very free. All those concerned in what are accepted as the fine arts, the learned sciences and professions, surround themselves with the history, literature, and concrete examples of the work with which they are particularly engaged. Yet it is only in very rare instances that such an atmosphere, with its material appurtenances, is to be found in a printing office. Art does not flourish in hidden places, nor under restraint, nor in ignorance of what talent and genius have accomplished and are now accomplishing throughout the world. For to follow precedent wisely does not mean to imitate

abcdefghijklmnopqrstuvwxy  
ABCDEFGHIJKLMN OPQRSTUVWXYZ  
\$1234567890

10 Point No. 11K, 10 Set

MONOTYPE FACES

The best kind of originality is that which comes after a sound apprenticeship; that which shall prove to be the blending of a firm conception of all useful precedent and the progressive tendencies of an able mind. For, let any man be as able and original as he may, he cannot afford to discard knowledge of what has gone before or what is now going on in his own trade and profession. If the printers of today do not wish to be esteemed too arrogant when they term this calling of theirs an art, they must be willing, and show that they are willing, to subject it to such laws as have made its sister arts so very free. All those concerned in what are accepted as the fine arts, the learned sciences and professions, surround themselves with the history, literature, and the concrete examples of the work with which they are par-

abcdefghijklmnopqrstuvwxy  
ABCDEFGHIJKLMN OPQRSTUVWXYZ  
\$1234567890

12 Point No. 11K, 12 Set

MONOTYPE FACES

The best kind of originality is that which comes after a sound apprenticeship; that which shall prove to be the blending of a firm conception of all useful precedent and the progressive tendencies of an able mind. For, let a man be as able and original as he may, he cannot afford to discard a knowledge of what has gone before or what is now going on in his own trade and profession. If the printers of today do not wish to be esteemed arrogant when they term this calling of theirs an art, they must be willing, and show that they are willing, to subject it to such laws

abcdefghijklmnopqrstuvwxy  
ABCDEFGHIJKLMN OPQRSTUVWXYZ  
\$1234567890

MONOTYPE FACES

The best kind of originality is that which comes after a sound apprenticeship; that which shall prove to be the blending of a firm conception of all useful precedent and the progressive tendencies of an able mind. For, let a man be as able and original as he may, he cannot afford to discard a knowledge of what has gone before or what is now going on in his own trade and profession. If the printers of today do not wish to be esteemed arrogant when they term this calling of theirs an art, they must be willing, and show that they are willing, to subject it to such laws as have made its sister arts so free. All those concerned in what are ac-

14 Point No. 1111

**THE COMPLETE MONOTYPE**

*Is the Only Machine that will Supply All of the Material  
Needed in the Composing Room*

**\$1234567890**

18 Point No. 1111

**INCREASED PRODUCTION**

*With System and Economy are Always to be  
Found Where There is a Monotype*

**\$1234567890**

24 Point No. 1111

**WITH HIGH QUALITY**

*As an Asset, Satisfaction is Assured  
from Your Monotype*

**\$1234567890**

30 Point No. 1111

**POOR WORKMANSHIP**

*Is Dear at any Price: Offer  
the Best—Monotype*

**\$1234567890**

36 Point No. 1111

**MONOTYPE**

*Gives Very Best Results*

**\$1234567890**

# No. 111J. Job Arrangement C1

## Composition Matrices

6 Point No. 111J, 6½ Set

### MONOTYPE FACES

The best kind of originality is that which comes after a sound apprenticeship; that which shall prove to be the blending of a firm conception of all useful precedent and the progressive tendencies of an able mind. For, let a man be as able and original as he may, he cannot afford to discard knowledge of what has gone before or what is now going on in his own trade and profession. If the printers of today do not wish to be esteemed arrogant when they term this calling of theirs an art, they must be willing, and show that they are willing, to subject it to such laws as have made its sister arts so free. All those concerned in what are accepted as the fine arts, the learned sciences, and professions surround themselves with the history, literature, and concrete examples of the work with which they are particularly engaged. Yet it is only in rare instances that such an atmosphere, with its material appurtenances, is to be found in a printing office. Art does not flourish in hidden places, nor under restraint, nor in ignorance of what talent and genius have accomplished and are accomplishing throughout the world. For to follow precedent wisely does not mean to imitate slavishly one great exemplar, but to study all masters faithfully, letting their great achievements sink slowly into the mind in order that we may patiently derive from the richness of our acquired knowledge and organized system an attitude of our own. The sprightly minded young man, who with his first business breath projects the new and startling, inevitably becomes tiresome, and is driven to an early disappearance; while the slower, more solidly endowed student will at least spend as much of his time in avoiding mistakes as in evolving brilliant schemes wherewith to dazzle his contemporaries. The best kind of originality is that which comes after a sound apprenticeship; that which shall prove to be the blending of a firm conception of all useful precedent and the progressive tendencies of an able mind. For, let a man be as able and original as he may, he cannot afford to discard knowledge of what has gone before or what is now going on in his own trade and profession. If the printers of today do not wish to be esteemed arrogant when they term this calling of theirs

abcdefghijklmnopqrstuvwxy

ABCDEFGHIJKLMNPOQRSTUVWXYZ

\$1234567890

8 Point No. 111J, 8 Set

### MONOTYPE FACES

The best kind of originality is that which comes after a sound apprenticeship; that which shall prove to be the blending of a firm conception of all useful precedent and the progressive tendencies of an able mind. For, let a man be as able and original as he may, he cannot afford to discard knowledge of what has gone before or what is now going on in his own trade and profession. If the printers of today do not wish to be esteemed arrogant when they term this calling of theirs an art, they must be willing, and show that they are willing, to subject it to such laws as have made its sister arts so free. All those concerned in what are accepted as the fine arts, the learned sciences, and professions surround themselves with the history, the literature, and concrete examples of the work with which they may be particularly engaged. Yet it is only in rare instances that such an atmosphere, with its material appurtenances, is to be found in a printing office. Art does not flourish in hidden places, nor under restraint, nor in ignorance of what talent and genius have accomplished and are now accomplishing throughout the world. For to follow precedent wisely does not mean to imitate slavishly one great exemplar, but to study all the masters faithfully, letting their great achievements sink slowly into the mind in order that we may patiently derive from the richness of our acquired knowledge and organized system an attitude

abcdefghijklmnopqrstuvwxy

ABCDEFGHIJKLMNPOQRSTUVWXYZ

\$1234567890

10 Point No. 111J, 10 Set

### MONOTYPE FACES

The best kind of originality is that which comes after a sound apprenticeship; that which shall prove to be the blending of a firm conception of all useful precedent and the progressive tendencies of an able mind. For, let a man be as able and original as he may, he cannot afford to discard knowledge of what has gone before or what is now going on in his own trade and profession. If the printers of today do not wish to be esteemed arrogant when they term this calling of theirs an art, they must be willing, and show that they are willing, to subject it to such laws as have made its sister arts so free. All those concerned in what are accepted as the fine arts, the learned sciences, and professions surround themselves with the history, literature, and concrete examples of the work with which they are particularly engaged. Yet it is only in rare instances that such an atmosphere, with its material appurtenances, is to be found in the printing office. Art does not flourish in hidden places, nor under restraint, nor in ignorance of

abcdefghijklmnopqrstuvwxy

ABCDEFGHIJKLMNPOQRSTUVWXYZ

\$1234567890

11 Point No. 111J, 11 Set

### MONOTYPE FACES

The very best kind of originality is that which comes after a thorough apprenticeship; that which shall prove itself to be the blending of a firm conception of all useful precedent and the progressive tendencies of an able mind. For, let a man be as able and original as he may, he cannot afford to discard knowledge of what has gone before or what is now going on in his own trade and profession. If the printers of today do not wish to be esteemed arrogant when they term this calling of theirs an art, they must be willing, and show that they are willing, to subject it to such laws as have made its sister arts so free. All those concerned in what are accepted as the fine arts, the learned sciences, and the professions surround themselves with the history, literature, and concrete examples of the work with which they are particularly engaged. Yet it is only in very rare instances that such an

abcdefghijklmnopqrstuvwxy

ABCDEFGHIJKLMNPOQRSTUVWXYZ

\$1234567890

# No. 111J. Job Arrangement C1

## Composition Matrices

12 Point No. 111J, 12 Set

### MONOTYPE FACES

The best kind of originality is that which comes after a sound apprenticeship; that which shall prove to be the blending of a firm conception of all useful precedent and the progressive tendencies of an able mind. For, let any man be as able and original as he may, he cannot afford to discard knowledge of what has gone before or what is now going on in his own trade and profession. If the printers of today do not wish to be esteemed arrogant when they term this calling of theirs an art, they must be willing, and show that they are willing, to subject it to such laws as have made its sister arts so free. All those concerned in what are accepted as the fine arts, the learned sciences, and

### MONOTYPE FACES

The best kind of originality is that which comes after a sound apprenticeship; that which shall prove to be the blending of a firm conception of all useful precedent and the progressive tendencies of an able mind. For, let any man be as able and original as he may, he cannot afford to discard knowledge of what has gone before or what is now going on in his own trade and profession. If the printers of today do not wish to be esteemed arrogant when they term this calling of theirs an art, they must be willing, and show that they are willing, to subject it to such laws as have made its sister arts so free. All those concerned in what are accepted as the fine arts, the learned sciences, and professions surround themselves with the history, literature, and concrete examples

abcdefghijklmnopqrstuvwxy

ABCDEFGHIJKLMN OPQRSTUVWXYZ

\$1234567890

14 Point No. 111

**YOU MAY BE ABLE TO MAKE MONEY**  
Without Owning and Operating a Monotype or Keeping your Plant up-to-date  
with the Modern Improvements of the Printing Business  
**\$1234567890**

18 Point No. 111

**BUT YOU ARE WASTING ENERGY**  
Which Could and Should Easily Pay you Greater Dividends with  
Considerably Less Effort and Worry  
**\$1234567890**

24 Point No. 111

**A MONOTYPE EQUIPMENT**  
Will Easily Save Many Composing and Pressroom  
Expenses Now Thought Necessary  
**\$1234567890**

30 Point No. 111

**TIME IS MONEY**  
And the Monotype Will Save Both. It  
is a Steady Producer  
**\$1234567890**

36 Point No. 111

**LABOR COSTS**  
Are Reduced to a Large Extent  
**\$1234567890**

# No. 210J. Job Arrangement C4

## Composition Matrices

10 Point No. 210J, 7 Set

### MONOTYPE FACES

The best kind of originality is that which comes after a sound apprenticeship; that which shall prove to be the blending of a firm conception of all useful precedent and the progressive tendencies of an able mind. For, let a man be as able and original as he may, he cannot afford to discard knowledge of what has gone before or what is now going on in his own trade and profession. If the printers of today do not wish to be esteemed arrogant when they term this calling of theirs an art, they must be willing, and show that they are willing, to subject it to such laws as have made its sister arts so free. All those concerned in what are accepted as the fine arts, the learned sciences, and the professions surround themselves with the history, the literature, and concrete examples of the work with which they are particularly engaged. Yet it is only in very rare instances that such an atmosphere, with its material appurtenances, is to be found in a printing office. Art does not flourish in hidden places, nor under restraint, nor in ignorance of what talent and genius have accomplished and are now accomplishing throughout the world. For to follow precedent wisely does not mean to imitate slavishly one great exemplar, but to study all the masters

abcdefghijklmnopqrstuvwxyz  
ABCDEFGHIJKLMNOPQRSTUVWXYZ  
\$1234567890

### MONOTYPE FACES

The best kind of originality is that which comes after a sound apprenticeship; that which shall prove to be the blending of a firm conception of all useful precedent and the progressive tendencies of an able mind. For, let a man be as able and original as he may, he cannot afford to discard knowledge of what has gone before or what is now going on in his own trade and profession. If the printers of today do not wish to be esteemed arrogant when they term this calling of theirs an art, they must be willing, and show that they are willing, to subject it to such laws as have made its sister arts so free. All those concerned in what are accepted as the fine arts, the learned sciences, and the professions surround themselves with the history, the literature, and concrete examples of the work with which they are particularly engaged. Yet it is only in very rare instances that such an atmosphere, with its material appurtenances, is to be found in a printing office. Art does not flourish in hidden places, nor under restraint, nor in ignorance of what talent and genius have accomplished and are now accomplishing throughout the world. For to follow precedent wisely does not mean to imitate slavishly one great exemplar, but to study all the masters faithfully, letting their great achievements sink slowly into the mind in order that we may patiently derive from the richness of our acquired knowledge and organized system an attitude of our own. The sprightly

12 Point No. 210J, 8½ Set

### MONOTYPE FACES

The best kind of originality is that which comes after a sound apprenticeship; that which shall prove to be the blending of a firm conception of all useful precedent and the progressive tendencies of an able mind. For, let a man be as able and original as he may, he cannot afford to discard knowledge of what has gone before or what is now going on in his own trade and profession. If the printers of today do not wish to be esteemed arrogant when they term this calling of theirs an art, they must be willing, and show that they are willing, to subject it to such laws as have made its sister arts so free. All those concerned in what are accepted as the fine arts, the learned sciences and the professions, surround themselves with the history, the literature, and concrete examples of the work with which they are particularly engaged. Yet it is only in very rare instances that such an atmosphere, with

abcdefghijklmnopqrstuvwxyz  
ABCDEFGHIJKLMNOPQRSTUVWXYZ  
\$1234567890

### MONOTYPE FACES

The best kind of originality is that which comes after a sound apprenticeship; that which shall prove to be the blending of a firm conception of all useful precedent and the progressive tendencies of an able mind. For, let a man be as able and original as he may, he cannot afford to discard knowledge of what has gone before or what is now going on in his own trade and profession. If the printers of today do not wish to be esteemed arrogant when they term this calling of theirs an art, they must be willing, and show that they are willing, to subject it to such laws as have made its sister arts so free. All those concerned in what are accepted as the fine arts, the learned sciences and the professions, surround themselves with the history, the literature, and concrete examples of the work with which they are particularly engaged. Yet it is only in very rare instances that such an atmosphere, with its material appurtenances, is to be found in a printing office. Art does not flourish in hidden places, nor under

14 Point No. 210

**OUR TYPE AND RULE CASTER**

**Furnishes Better Typography to Interest your Advertisers; Eliminates Distribution; Supplies  
New Type and New Rule for Every Ad**

**\$1234567890**

18 Point No. 210

**TYPE OF LARGER POINT SIZES**

**And Fatter Faces Provided on the Monotype Type and Rule Caster Creates a  
Demand for More Space in Your Advertising Columns**

**\$1234567890**

24 Point No. 210

**MONOTYPE QUALITY IS THE BEST**

**And Only Lever to Raise Prices and Increase Your Profits. New  
Type Assures Good Press Work**

**\$1234567890**

30 Point No. 210

**COMPOSITORS DO NOT STOP**

**Productive Work to Distribute Lines that do not Fit  
the Required Measure**

**\$1234567890**

36 Point No. 210

**TURNS COMPOSING ROOM**

**Maintenance into Profit—not an Expense**

**\$1234567890**



# No. 28J. Job Arrangement C2

## Composition Matrices

5½ Point No. 28J, 6½ Set

### MONOTYPE FACES

The best kind of originality is that which comes after a sound apprenticeship; that which shall prove to be the blending of a firm conception of all useful precedent and the progressive tendencies of an able mind. For, let a man be as able and original as he may, he cannot afford to discard knowledge of what has gone before or what is now going on in his own trade and profession. If the printers of today do not wish to be esteemed arrogant when they term this calling of theirs an art, they must be willing, and show that they are willing, to subject it to such laws as have made its sister arts so free. All those concerned in what are accepted as the fine arts, the learned sciences, and professions surround themselves with the history, literature, and concrete examples of the work with which they are engaged. Yet it is only in rare instances that such an atmosphere, with its material appurtenances, is to be found in a printing office. Art does not flourish in hidden places, nor under restraint, nor in ignorance of what talent and genius have accomplished and are now accomplishing throughout the world. For to follow precedent wisely does not mean to imitate slavishly one great exemplar, but to study all masters faithfully, letting their great achievements sink slowly into the mind in order that we may patiently derive from the richness of our acquired knowledge and organized system an attitude of our own. The sprightly minded young man, who with his first business breath projects the new and startling, inevitably becomes tiresome, and is driven to an early disappearance; while the slower, more solidly endowed student will at least spend as much of his time in avoiding mistakes as in evolving brilliant schemes wherewith to dazzle his contemporaries. The best kind of originality is that which comes after a sound apprenticeship; that which shall prove to be the blending of a firm conception of all useful precedent and the progressive tendencies of an able mind. For, let a man be as able and original as he may, he cannot afford to discard knowledge of what has gone before or what is now going on in his own trade and profession. If the printers of today do not wish to be esteemed arrogant when they term this calling of theirs an art, they

abcdefghijklmnopqrstuvwxy  
ABCDEFGHIJKLMNQPQRSTUVWXYZ  
\$1234567890

7 Point No. 28J, 8 Set

### MONOTYPE FACES

The best kind of originality is that which comes after a sound apprenticeship; that which shall prove to be the blending of a firm conception of all useful precedent and the progressive tendencies of an able mind. For, let a man be as able and original as he may, he cannot afford to discard knowledge of what has gone before or what is now going on in his own trade and profession. If the printers of today do not wish to be esteemed too arrogant when they term this calling of theirs an art, they must be willing, and show that they are willing, to subject it to such laws as have made its sister arts so free. All those concerned in what are accepted as the fine arts, the learned sciences, and the professions surround themselves with the history, the literature, and concrete examples of the work with which they are particularly engaged. Yet it is only in rare instances that such an atmosphere, with its material appurtenances, is to be found in a printing office. Art does not flourish in hidden places, nor under restraint, nor in ignorance of what talent and genius have accomplished and are now accomplishing throughout the world. For to follow precedent wisely does not mean to imitate slavishly one great exemplar, but to study all masters faithfully, letting their great achievements sink slowly into the mind in order that we may patiently derive from the richness of our acquired knowledge and organized system an attitude of our own. The sprightly minded young man, who with his first business breath projects the new and startling, inevitably becomes tiresome, and is driven to an early disappearance; while the slower, more solidly endowed

abcdefghijklmnopqrstuvwxy  
ABCDEFGHIJKLMNQPQRSTUVWXYZ  
\$1234567890

6 Point No. 28J, 7 Set

### MONOTYPE FACES

The best kind of originality is that which comes after a sound apprenticeship; that which shall prove to be the blending of a firm conception of all useful precedent and the progressive tendencies of an able mind. For, let a man be as able and original as he may, he cannot afford to discard knowledge of what has gone before or what is now going on in his own trade and profession. If the printers of today do not wish to be esteemed arrogant when they term this calling of theirs an art, they must be willing, and show that they are willing, to subject it to such laws as have made its sister arts so free. All those concerned in what are accepted as the fine arts, the learned sciences, and professions surround themselves with the history, literature, and concrete examples of the work with which they are particularly engaged. Yet it is only in very rare instances that such an atmosphere, with its material appurtenances, is to be found in a printing office. Art does not flourish in hidden places, nor under restraint, nor in ignorance of what talent and genius have accomplished and are accomplishing throughout the world. For to follow precedent wisely does not mean to imitate slavishly one great exemplar, but to study all masters faithfully, letting their great achievements sink slowly into the mind in order that we may patiently derive from the richness of our acquired knowledge and organized system an attitude of our own. The sprightly minded young man, who with his first business breath projects the new and startling, inevitably becomes tiresome, and is driven to an early disappearance; while the slower, more solidly endowed student will at least spend as much of his time in avoiding mistakes as in evolving brilliant schemes wherewith to dazzle his contemporaries. The best kind of originality is that which comes after a sound apprenticeship; that which shall prove to

abcdefghijklmnopqrstuvwxy  
ABCDEFGHIJKLMNQPQRSTUVWXYZ  
\$1234567890

8 Point No. 28J, 8½ Set

### MONOTYPE FACES

The best kind of originality is that which comes after a sound apprenticeship; that which shall prove to be the blending of a firm conception of all useful precedent and the progressive tendencies of an able mind. For, let a man be as able and original as he may, he cannot afford to discard knowledge of what has gone before or what is now going on in his own trade and profession. If the printers of today do not wish to be esteemed arrogant when they term this calling of theirs an art, they must be willing, and show that they are willing, to subject it to such laws as have made its sister arts so free. All those concerned in what are accepted as the fine arts, the learned sciences, and professions surround themselves with the history, literature, and concrete examples of the work with which they are particularly engaged. Yet it is only in very rare instances that such an atmosphere, with its material appurtenances, is to be found in a printing office. Art does not flourish in hidden places, nor under restraint, nor in ignorance of what talent and genius have accomplished and are accomplishing throughout the world. For to follow precedent wisely does not mean to imitate slavishly one great exemplar, but to study all the masters faithfully, letting their great achievements sink slowly into the mind in order that we may patiently derive from the richness

abcdefghijklmnopqrstuvwxy  
ABCDEFGHIJKLMNQPQRSTUVWXYZ  
\$1234567890

# No. 28J. Job Arrangement C2

## Composition Matrices

10 Point No. 28J, 10½ Set

### MONOTYPE FACES

The best kind of originality is that which comes after a sound apprenticeship; that which shall prove to be the blending of a firm conception of all useful precedent and the progressive tendencies of an able mind. For, let a man be as able and as original as he may, he cannot afford to discard knowledge of what has gone before or what is now going on in his own trade and profession. If the printers of to-day do not wish to be esteemed arrogant when they term this calling of theirs an art, they must be willing, and show that they are willing, to subject it to such laws as have made its sister arts so free. All those concerned in what are accepted as the fine arts, the learned sciences, and the professions surround themselves with the history, literature, and concrete examples of the work with which they are particularly engaged. Yet it is only in rare instances that such an atmosphere, with its

abcdefghijklmnopqrstuvwxy  
ABCDEFGHIJKLMN**OP**QRSTU**VW**XYZ  
\$1234567890

12 Point No. 28J, 12 Set

### MONOTYPE FACES

The best kind of originality is that which comes after a sound apprenticeship; that which shall prove to be the blending of a firm conception of all useful precedent and the progressive tendencies of an able mind. For, let a man be as able and original as he may, he cannot well afford to discard knowledge of what has gone before or what is now going on in his own trade and profession. If the printers of today do not wish to be esteemed arrogant when they term this calling of theirs an art, they must be willing, and show that they are willing, to subject it to such laws as have made its sister arts so free. All those who are concerned in what

abcdefghijklmnopqrstuvwxy  
ABCDEFGHIJKLMN**OP**QRSTU**VW**  
\$1234567890

# No. 128J. Job Arrangement C1

## Composition Matrices

6 Point No. 128J, 8½ Set

### MONOTYPE FACES

The best kind of originality is that which comes after a sound apprenticeship; that which shall prove to be the blending of a firm conception of all useful precedent and the progressive tendencies of an able mind. For, let a man be as able and original as he may, he cannot afford to discard knowledge of what has gone before or what is now going on in his own trade and profession. If the printers of today do not wish to be esteemed arrogant when they term this calling of theirs an art, they must be willing, and show that they are willing, to subject it to such laws as have made its sister arts so free. All those concerned in what are accepted as the fine arts, the learned sciences, and professions surround themselves with the history, the literature, and concrete examples of the work with which they may be particularly engaged. Yet it is only in rare instances that such an atmosphere, with its material appurtenances, is to be found in a printing office. Art does not flourish in hidden places, nor under restraint, nor in ignorance of what talent and genius have accomplished and are now accomplishing throughout the world. For to follow precedent wisely does not mean to imitate slavishly one great exemplar, but to study all the masters faithfully, letting their greatest achievements sink slowly into the mind in order that we may patiently derive from the richness of our acquired knowledge and organized system an attitude of our own. The sprightly minded young man, who with his first business breath projects the new and startling, inevitably becomes tiresome, and is driven to an early disappearance; while the slower, more solidly endowed student will at least spend as much of his time in avoiding mistakes as in evolving brilliant schemes wherewith to dazzle his contemporaries. The best kind of originality is that which comes after a sound apprenticeship; that which shall prove to be the blending of a firm conception of all useful precedent and the progressive tendencies of an able mind. For, let a man be as able and original as he may, he cannot afford to discard knowledge

abcdefghijklmnopqrstuvwxyz  
 ABCDEFGHIJKLMNOPQRSTUVWXYZ  
 \$1234567890

8 Point No. 128J, 10 Set

### MONOTYPE FACES

The best kind of originality is that which comes after a sound apprenticeship; that which shall prove to be the blending of a firm conception of all useful precedent and the progressive tendencies of an able mind. For, let a man be as able and original as he may, he cannot afford to discard knowledge of what has gone before or what is now going on in his own trade and profession. If the printers of today do not wish to be esteemed too arrogant when they term this calling of theirs an art, they must be willing, and show that they are willing, to subject it to such laws as have made its sister arts so free. All those concerned in what are accepted as the fine arts, the learned sciences, and professions, surround themselves with the history, literature, and concrete examples of the work with which they are particularly engaged. Yet it is only in rare instances that such an atmosphere, with its material appurtenances, is to be found in a printing office. Art does not flourish in hidden places, nor under restraint, nor even in ignorance of what talent and genius have accomplished and are just now accomplishing throughout the world. For to follow precedent wisely does not mean to imitate slavishly one great exemplar, but to study all the masters faithfully, letting their greatest achievements sink slowly into the mind in order that we

abcdefghijklmnopqrstuvwxyz  
 ABCDEFGHIJKLMNOPQRSTUVWXYZ  
 \$1234567890

10 Point No. 128J, 12 Set

### MONOTYPE FACES

The best kind of originality is that which comes after a sound apprenticeship; that which shall prove to be the blending of a firm conception of all useful precedent and the progressive tendencies of an able mind. For, let any man be as able and original as he may, he cannot afford to discard knowledge of what has gone before or what is now going on in his own trade and profession. If the printers of today do not wish to be esteemed arrogant when they term this calling of theirs an art, they must be willing, and show that they are willing, to subject it to such laws as have made its sister arts so free. All those concerned in what are accepted as

abcdefghijklmnopqrstuvwxyz  
 ABCDEFGHIJKLMNOPQRSTUVWXYZ  
 \$1234567890

### MONOTYPE FACES

The best kind of originality is that which comes after a sound apprenticeship; that which shall prove to be the blending of a firm conception of all useful precedent and the progressive tendencies of an able mind. For, let any man be as able and original as he may, he cannot afford to discard knowledge of what has gone before or what is now going on in his own trade and profession. If the printers of today do not wish to be esteemed arrogant when they term this calling of theirs an art, they must be willing, and show that they are willing, to subject it to such laws as have made its sister arts so free. All those concerned in what are accepted as the fine arts, the learned sciences and professions surround themselves with the history, literature, and concrete ex-

# No. 39J. Job Arrangement C2

## Composition Matrices

5 Point No. 39J, 6½ Set

### MONOTYPE FACES

The best kind of originality is that which comes after a sound apprenticeship; that which shall prove to be the blending of a firm conception of all useful precedent and the progressive tendencies of an able mind. For, let a man be as able and original as he may, he cannot afford to discard knowledge of what has gone before or what is now going on in his own trade and profession. If the printers of today do not wish to be esteemed arrogant when they term this calling of theirs an art, they must be willing, and show that they are willing, to subject it to such laws as have made its sister arts so free. All those concerned in what are accepted as the fine arts, the learned sciences and the professions surround themselves with the history, literature, and the concrete examples of the work with which they are particularly engaged. Yet it is only in rare instances that such an atmosphere, with its material appurtenances, is to be found in a printing office. Art does not flourish in hidden places, nor under restraint, nor in ignorance of what talent and genius have accomplished and are accomplishing throughout the world. For to follow precedent wisely does not mean to imitate slavishly one great exemplar, but to study all masters faithfully, letting their great achievements sink slowly into the mind in order that we may patiently derive from the richness of our acquired knowledge and organized system an attitude of our own. The sprightly minded young man,

abcdefghijklmnopqrstuvwxy  
 ABCDEFGHIJKLMNOPQRSTUVWXYZ  
 \$1234567890

6 Point No. 39J, 7½ Set

### MONOTYPE FACES

The best kind of originality is that which comes after a sound apprenticeship; that which shall prove to be the blending of a firm conception of all useful precedent and the progressive tendencies of an able mind. For, let a man be as able and original as he may, he cannot afford to discard knowledge of what has gone before or what is now going on in his own trade and his profession. If the printers of today do not wish to be esteemed too arrogant when they term this calling of theirs an art, they must be willing, and show that they are willing, to subject it to such laws as have made its sister arts so free. All those concerned in what are accepted as the fine arts, the learned sciences, and the professions surround themselves with the history, the literature, and concrete examples of the work with which they are particularly engaged. Yet it is only in rare instances that such an atmosphere, with its material appurtenances, is to be found in a printing office. Art does not flourish in hidden places, nor under restraint, nor in ignorance of what talent and genius have accomplished

abcdefghijklmnopqrstuvwxy  
 ABCDEFGHIJKLMNOPQRSTUVWXYZ  
 \$1234567890

8 Point No. 39J, 9 Set

### MONOTYPE FACES

The best kind of originality is that which comes after a sound apprenticeship; that which shall prove to be the blending of a firm conception of all useful precedent and of the progressive tendencies of an able mind. For, let a man be as able and original as he may, he cannot afford to discard knowledge of what has gone before or what is now going on in his own trade and profession. If the printers of today do not wish to be esteemed arrogant when they term this calling of theirs an art they must be willing, and show that they are willing, to subject it to such laws as have made its sister arts so free. All those concerned in what are accepted as the fine arts, the learned sciences, and professions surround themselves with the

abcdefghijklmnopqrstuvwxy  
 ABCDEFGHIJKLMNOPQRSTUVWXYZ  
 \$1234567890

10 Point No. 39J, 11 Set

### MONOTYPE FACES

The very best kind of originality is that which comes after a sound apprenticeship; that which shall prove itself to be the blending of a firm conception of all useful precedent and the progressive tendencies of an able mind. For, let a man be as able and original as he may, he cannot afford to discard knowledge of what has gone before or what is now going on in his own trade and profession. If the printers of today do not wish to be esteemed arrogant when they term this calling of theirs an art, they must be willing, and show that they are willing, to subject it to such laws as have made its sister arts so free. All those concerned in what are accepted as the fine arts, the learned sciences, and professions surround themselves with the history, literature, and concrete exam-

abcdefghijklmnopqrstuvwxy  
 ABCDEFGHIJKLMNOPQRSTUVWXYZ  
 \$1234567890

12 Point No. 39J, 12½ Set

### MONOTYPE FACES

The best kind of originality is that which comes after a sound apprenticeship; that which shall prove to be the blending of a firm conception of all useful precedent and the progressive tendencies of a clever mind. For, let any man be as able and original as he may, he cannot afford to discard a knowledge of what has gone before or what is now going on in his own trade and profession. If the printers of today do not wish to be esteemed arrogant when they term this calling of theirs an art, they must be willing, and show that they are willing, to

abcdefghijklmnopqrstuvwxy  
 ABCDEFGHIJKLMNOPQRSTUVWXYZ  
 \$1234567890

14 Point No. 39

**THE MATRIX LIBRARY**

**Supplies 850 Different Fonts of Attractive Faces for Use  
when You Please as Long as You Please**

**\$1234567890**

18 Point No. 39

**100 POUNDS A DAY**

**Of Assorted Type. This is the Record of a  
Washington Newspaper Plant**

**\$1234567890**

24 Point No. 39

**ALL OLD TYPE**

**Converted into New and Usable Faces  
for Newspaper Ads.**

**\$1234567890**

30 Point No. 39

**MATRIX SERVICE**

**Satisfies all Library Members  
throughout the Country**

**\$1234567890**

36 Point No. 39

**MONOTYPE USERS**

**Will Tell You; They Know**

**\$1234567890**

# No. 89J. Job Arrangement C1

## Composition Matrices

6 Point No. 89J, 7 Set

### MONOTYPE FACES

The best kind of originality is that which comes after a sound apprenticeship; that which shall prove itself to be the blending of a firm conception of useful precedent and the progressive tendencies of an able mind. For, let a man be as able and original as he may, he cannot afford to discard knowledge of what has gone before or what is now going on in his own trade and profession. If the printers of today do not wish to be esteemed arrogant when they term this calling of theirs an art, they must be willing, and show that they are willing, to subject it to such laws as have made its sister arts so free. All those concerned in what are accepted as the fine arts, the learned sciences and professions, surround themselves with the history, literature, and concrete examples of the work with which they are particularly engaged. Yet it is only in rare instances that such an atmosphere, with its material appurtenances, is to be found in a printing office. Art does not flourish in hidden places, nor under restraint, nor in ignorance of what talent and genius have accomplished and are accomplishing throughout the world. For to follow precedent wisely does not mean to imitate slavishly one great exemplar, but to study all masters faithfully, letting their great achievements sink slowly into the mind in order that we may patiently derive from the richness of our acquired knowledge and organized system an attitude of our own. The sprightly minded young man, who with his first business breath projects the new and startling, inevitably becomes tiresome, and is driven to an early disappearance; while the slower, more solidly endowed student will at least spend as much of his time in avoiding mistakes as in evolving brilliant schemes wherewith to dazzle his contemporaries. The best kind of originality is that which comes after a sound apprenticeship; that which shall prove to be the blending of a firm conception of all useful precedent and the progressive tendencies of an able mind. For, let a man be as able and original as he may, he cannot afford to discard knowledge of what has gone before or what is now going on in his own trade and profession.

abcdefghijklmnopqrstuvwxy

ABCDEFGHIJKLMNOPQRSTUVWXYZ

\$1234567890

10 Point No. 89J, 10 Set

### MONOTYPE FACES

The best kind of originality is that which comes after a sound apprenticeship; that which shall prove to be the blending of a firm conception of all useful precedent and the progressive tendencies of an able mind. For, let a man be as able and original as he may, he cannot afford to discard knowledge of what has gone before or what is now going on in his own trade and profession. If the printers of today do not wish to be esteemed too arrogant when they term this calling of theirs an art, they must be willing, and show that they are willing, to subject it to just such laws as have made its sister arts so free. All those concerned in what are accepted as the fine arts, the learned sciences and professions, surround themselves with the history, literature, and concrete examples of the work with which they are particularly engaged. Yet it is only in rare instances that such an atmosphere, with its material appurtenances, is to be found in a printing office. Art does not flourish in hidden places, nor under restraint, nor in ignorance of what talent

abcdefghijklmnopqrstuvwxy

ABCDEFGHIJKLMNOPQRSTUVWXYZ

\$1234567890

8 Point No. 89J, 8½ Set

### MONOTYPE FACES

The best kind of originality is that which comes after a sound apprenticeship; that which shall prove to be the blending of a firm conception of all useful precedent and the progressive tendencies of an able mind. For, let a man be as able and original as he may, he cannot afford to discard knowledge of what has gone before or what is now going on in his own trade and profession. If the printers of today do not wish to be esteemed arrogant when they term this calling of theirs an art, they must be willing, and show that they are willing, to subject it to such laws as have made its sister arts so free. All those concerned in what are accepted as the fine arts, the learned sciences and professions, surround themselves with the history, the literature, and concrete examples of the work with which they may be particularly engaged. Yet it is only in rare instances that such an atmosphere, with its material appurtenances, is to be found in a printing office. Art does not flourish in hidden places, nor under restraint, nor in ignorance of what talent and genius have accomplished and are now accomplishing throughout the world. For to follow precedent wisely does not mean to imitate slavishly one great exemplar, but to study all the masters faithfully, letting their great achievements sink slowly into the mind in order that we may patiently derive from the

abcdefghijklmnopqrstuvwxy

ABCDEFGHIJKLMNOPQRSTUVWXYZ

\$1234567890

12 Point No. 89J, 12 Set

### MONOTYPE FACES

The best kind of originality is that which comes after a sound apprenticeship; that which shall prove to be the blending of a firm conception of all useful precedent and the progressive tendencies of an able mind. For, let any man be as able and original as he may, he cannot afford to discard knowledge of what has gone before or what is now going on in his own trade and profession. If the printers of today do not wish to be esteemed arrogant when they term this calling of theirs an art, they must be willing, and show that they are willing, to subject it to such laws as have made its sister arts so free. All those concerned in what are accepted as the fine arts, the learned sciences and the professions, surround themselves with the

abcdefghijklmnopqrstuvwxy

ABCDEFGHIJKLMNOPQRSTUVWXYZ

\$1234567890

14 Point No. 89

**THE ONLY TYPE CASTER**

**That Makes New Type and Better Type Cheaper than Old Type can be Distributed; we can Prove this**

**\$1234567890**

18 Point No. 89

**ADDING FACES EVERY WEEK**

**To Keep the Monotype Equipment up to the Minute with Attractive and Up-to-Date Faces**

**\$1234567890**

24 Point No. 89

**A CONVERTIBLE MACHINE**

**From a Type Caster to a Composing Machine just when you want it**

**\$1234567890**

30 Point No. 89

**YOUR INVESTMENT**

**Protected by this Convertible Feature of the Busy Monotype**

**\$1234567890**

36 Point No. 89

**READY TO USE**

**Doesn't make Near Perfect Type**

**\$1234567890**

# No. 89K. Job Arrangement C1

## Composition Matrices

6 Point No. 89K, 7 Set

### MONOTYPE FACES

*The best kind of originality is that which comes after a sound apprenticeship; that which shall prove itself to be the blending of a firm conception of useful precedent and the progressive tendencies of an able mind. For, let a man be as able and original as he may, he cannot afford to discard knowledge of what has gone before or what is now going on in his own trade and profession. If the printers of today do not wish to be esteemed arrogant when they term this calling of theirs an art, they must be willing, and show that they are willing, to subject it to such laws as have made its sister arts so free. All those concerned in what are accepted as the fine arts, the learned sciences, and professions surround themselves with the history, literature, and concrete examples of the work with which they are particularly engaged. Yet it is only in rare instances that such an atmosphere, with its material appurtenances, is to be found in a printing office. Art does not flourish in hidden places, nor under restraint, nor in ignorance of what talent and genius have accomplished and are accomplishing throughout the world. For to follow precedent wisely does not mean to imitate slavishly one great exemplar, but to study all masters faithfully, letting their great achievements sink slowly into the mind in order that we may patiently derive from the richness of our acquired knowledge and organized system an attitude of our own. The sprightly minded young man, who with his first business breath projects the new and startling, inevitably becomes tiresome, and is driven to an early disappearance; while the slower, more solidly endowed student will at least spend as much of his time in avoiding mistakes as in evolving brilliant schemes wherewith to dazzle his contemporaries. The best kind of originality is that which comes after a sound apprenticeship; that which shall prove to be the blending of a firm conception of all useful precedent and the progressive tendencies of an able mind. For, let a man be as able and original as he may, he cannot afford to discard knowledge of what has gone before or what is now going on in his own trade and profession.*

abcdefghijklmnopqrstuwxyz

ABCDEFGHIJKLMN OPQRSTUVWXYZ

\$1234567890

10 Point No. 89K, 10 Set

### MONOTYPE FACES

*The best kind of originality is that which comes after a sound apprenticeship; that which shall prove to be the blending of a firm conception of all useful precedent and the progressive tendencies of an able mind. For, let a man be as able and original as he may, he cannot afford to discard knowledge of what has gone before or what is now going on in his own trade and profession. If the printers of today do not wish to be esteemed arrogant when they term this calling of theirs an art, they must be willing, and show that they are willing, to subject it to such laws as have made its sister arts so free. All those concerned in what are accepted as the fine arts, the learned sciences and professions, surround themselves with the history, literature, and concrete examples of the work with which they are particularly engaged. Yet it is only in rare instances that such an atmosphere, with its material appurtenances, is to be found in a printing office. Art does not flourish in hidden places, nor under restraint, nor in ignorance of what talent*

abcdefghijklmnopqrstuwxyz

ABCDEFGHIJKLMN OPQRSTUVWXYZ

\$1234567890

8 Point No. 89K, 8½ Set

### MONOTYPE FACES

*The best kind of originality is that which comes after a sound apprenticeship; that which shall prove to be the blending of a firm conception of all useful precedent and the progressive tendencies of an able mind. For, let a man be as able and original as he may, he cannot afford to discard knowledge of what has gone before or what is now going on in his own trade and profession. If the printers of today do not wish to be esteemed arrogant when they term this calling of theirs an art, they must be willing, and show that they are willing, to subject it to such laws as have made its sister arts so free. All those concerned in what are accepted as the fine arts, the learned sciences, and professions surround themselves with the history, the literature, and concrete examples of the work with which they may be particularly engaged. Yet it is only in rare instances that such an atmosphere, with its material appurtenances, is to be found in a printing office. Art does not flourish in hidden places, nor under restraint, nor in ignorance of what talent and genius have accomplished and are now accomplishing throughout the world. For to follow precedent wisely does not mean to imitate slavishly one great exemplar, but to study all the masters faithfully, letting their greatest achievements sink slowly into the mind in order that we may patiently derive from*

abcdefghijklmnopqrstuwxyz

ABCDEFGHIJKLMN OPQRSTUVWXYZ

\$1234567890

12 Point No. 89K, 12 Set

### MONOTYPE FACES

*The best kind of originality is that which comes after a sound apprenticeship; that which shall prove to be the blending of a firm conception of all useful precedent and the progressive tendencies of an able mind. For, let a man be as able and original as he may, he cannot afford to discard knowledge of what has gone before or what is now going on in his own trade and profession. If the printers of today do not wish to be esteemed arrogant when they term this calling of theirs an art, they must be willing, and show that they are willing, to subject it to such laws as have made its sister arts so free. All those concerned in what are accepted as the fine arts, and the learned sciences and professions surround themselves with the*

abcdefghijklmnopqrstuwxyz

ABCDEFGHIJKLMN OPQRSTUVWXYZ

\$1234567890



14 Point No. 891

**THE MONOTYPE SYSTEM**

*Forces no Fixed Combinations of Faces upon the Printer. Any Italic  
or Boldface may be used as Required*

**\$1234567890**

18 Point No. 891

**THE STYLE "D" KEYBOARD**

*Accepted as One of the Truly Great Developments in  
the Printing Industry*

**\$1234567890**

24 Point No. 891

**KEY ARRANGEMENT**

*And Action of the Monotype are the Same  
as All Standard Typewriters*

**\$1234567890**

30 Point No. 891

**FLEXIBLE FACILITIES**

*And High Quality are Selling Points  
for the Monotype Printer*

**\$1234567890**

36 Point No. 891

**QUALITY COUNTS**

*The Salesman's Best Friend*

**\$1234567890**

No. 103

Electro Display Matrices

18 Point No. 103

**THE ONLY MACHINE TO CONSIDER**

**For any kind of Matter to be kept Standing and Corrected for Later Editions  
Directories, Railway Tariffs, Time Tables, Club Lists, Etc.**

**\$1234567890**

24 Point No. 103

**THE MONOTYPE**

**ENABLES YOU TO DEVELOP YOUR BUSINESS ALONG  
THE LINE OF LEAST RESISTANCE**

**\$1234567890**

No. 108

Electro Display Matrices

14 Point No. 108

**ALL ROMAN, ITALIC AND BOLD FACES**

**On Standard Monotype Line for all Point Sizes from 5 to 12 Point Inclusive  
can be cast to Line at One Operation**

**\$1234567890**

18 Point No. 108

**TWO-LINE OR THREE-LINE BOLDFACE FIGURES**

**Combined with any size Roman for Newspaper Ad. and Catalogue  
Work. This is not a Slug Makeshift**

**\$1234567890**

# No. 119J. Job Arrangement C1

## Composition Matrices

6 Point No. 119J, 6 Set

### MONOTYPE FACES

The best kind of originality is that which comes after a sound apprenticeship; that which shall prove to be the blending of a firm conception of all useful precedent and the progressive tendencies of an able mind. For, let a man be as able and original as he may, he cannot afford to discard knowledge of what has gone before or what is now going on in his own trade and profession. If the printers of today do not wish to be esteemed arrogant when they term this calling of theirs an art, they must be willing, and show that they are willing, to subject it to such laws as have made its sister arts so free. All those concerned in what are accepted as the fine arts, the learned sciences, and professions surround themselves with the history, literature, and concrete examples of the work with which they are particularly engaged. Yet it is only in rare instances that such an atmosphere, with its material appurtenances, is to be found in a printing office. Art does not flourish in hidden places, nor under restraint, nor in ignorance of what talent and genius have accomplished and are now accomplishing throughout the world. For to follow precedent wisely does not mean to imitate slavishly one great exemplar, but to study all the masters faithfully, letting their great achievements sink slowly into the mind in order that we may patiently derive from the richness of our acquired knowledge and organized system an attitude of our own. The sprightly minded young man, who with his first business breath projects the new and startling, inevitably becomes tiresome, and is driven to an early disappearance; while the slower, more solidly endowed student will at least spend as much of his time in avoiding mistakes as in evolving brilliant schemes wherewith to dazzle his contemporaries. The very best kind of originality is that which comes after a sound apprenticeship; that which shall prove to be the blending of a firm conception of all useful precedent and the progressive tendencies of an able mind. For, let a man be as able and original as he may, he cannot afford to discard knowledge of what has gone before or what is now going on in his own trade and profession. If the printers of today do not wish to be esteemed arrogant when they term this calling of theirs an art, they must be willing, and show that they are willing, to subject it to such laws as have made its sister arts so free. All those concerned in what are accepted as the fine arts, the learned sciences, and

abcdefghijklmnopqrstuvwxy  
 ABCDEFGHIJKLMNOPQRSTUVWXYZ  
 \$1234567890

10 Point No. 119J, 9 Set

### MONOTYPE FACES

The best kind of originality is that which comes after a sound apprenticeship; that which shall prove to be the blending of a firm conception of all useful precedent and the progressive tendencies of an able mind. For, let a man be as able and original as he may, he cannot afford to discard knowledge of what has gone before or what is now going on in his own trade and profession. If the printers of today do not wish to be esteemed arrogant when they term this calling of theirs an art, they must be willing, and show that they are willing, to subject it to such laws as have made its sister arts so free. All those concerned in what are accepted as the fine arts, the learned sciences and professions, surround themselves with the history, the literature and concrete examples of the work with which they may be particularly engaged. Yet it is only in rare instances that such an atmosphere, with its material appurtenances, is to be found in the printing office. Art does not flourish in hidden places, nor under restraint, nor in ignorance of what talent and genius have accomplished and are still accomplishing throughout the world. For to follow all precedent wisely does not mean to imitate slavishly one

abcdefghijklmnopqrstuvwxy  
 ABCDEFGHIJKLMNOPQRSTUVWXYZ  
 \$1234567890

8 Point No. 119J, 7½ Set

### MONOTYPE FACES

The best kind of originality is that which comes after a sound apprenticeship; that which shall prove to be the blending of a firm conception of useful precedent and the progressive tendencies of an able mind. For, let a man be as able and original as he may, he cannot afford to discard knowledge of what has gone before or what is now going on in his own trade and profession. If the printers of today do not wish to be esteemed arrogant when they term this calling of theirs an art, they must be willing, and show that they are willing, to subject it to such laws as have made its sister arts so free. All those concerned in what are accepted as the fine arts, the learned sciences and the professions, surround themselves with the history, literature, and concrete examples of the work with which they are particularly engaged. Yet it is only in rare instances that such an atmosphere, with its material appurtenances, is to be found in the printing office. Art does not flourish in hidden places, nor under restraint, nor in ignorance of what talent and genius have accomplished and are now accomplishing throughout the world. For to follow all precedent wisely does not mean to imitate slavishly one great exemplar, but to study all the masters faithfully, letting their great achievements sink slowly into the mind in order that we may patiently derive from the richness of our acquired knowledge and organized system an attitude of our own. The sprightly minded young man, who with his first business breath projects the new and startling, inevitably becomes tiresome, and is driven to an early disappearance; while the slower, more solidly endowed student

abcdefghijklmnopqrstuvwxy  
 ABCDEFGHIJKLMNOPQRSTUVWXYZ  
 \$1234567890

12 Point No. 119J, 10½ Set

### MONOTYPE FACES

The best kind of originality is that which comes after a sound apprenticeship; that which shall prove to be the blending of a firm conception of all useful precedent and the progressive tendencies of an able mind. For, let a man be as able and original as he may, he cannot afford to discard knowledge of what has gone before or what is now going on in his own trade and profession. If the printers of today do not wish to be esteemed arrogant when they term this calling of theirs an art, they must be willing, and show that they are willing, to subject it to such laws as have made its sister arts so free. All those concerned in what are accepted as the fine arts, the learned sciences, and professions surround themselves with the history, literature, and concrete examples of the work with which they are particularly engaged. Yet it is

abcdefghijklmnopqrstuvwxy  
 ABCDEFGHIJKLMNOPQRSTUVWXYZ  
 \$1234567890

14 Point No. 119

**ASK MONOTYPE USERS: THEY KNOW**

**That the Improvements Constantly being Added to the Monotype Increase  
its Earning Power and Versatility**

**\$1234567890**

18 Point No. 119

**THE NEW CELLULAR MATRIX**

**Establishes a Standard of the Highest Quality that Cannot be  
Approached by Other Machines**

**\$1234567890**

24 Point No. 119

**HIGHER SELLING PRICES**

**Quickly Realized with the Unequaled Quality of  
Monotype Production**

**\$1234567890**

30 Point No. 119

**OUR LOW QUAD MOLD**

**Will Produce Spaces and Quads High or  
Low to Suit the Job**

**\$1234567890**

36 Point No. 119

**ACCURATE JUSTIFICATION**

**For any Measure to Sixty Picas**

**\$1234567890**

# No. 146J. Job Arrangement C1

## Composition Matrices

8 Point No. 146J, 8½ Set

### MONOTYPE FACES

The best kind of originality is that which comes after a sound apprenticeship; that which shall prove to be the blending of a firm conception of all useful precedent and the progressive tendencies of an able mind. For, let a man be as able and original as he may, he cannot afford to discard knowledge of what has gone before or what is now going on in his own trade and profession. If the printers of today do not wish to be esteemed arrogant when they term this calling of theirs an art, they must be willing, and show that they are willing, to subject it to such laws as have made its sister arts so free. All those concerned in what are accepted as the fine arts, the learned sciences, and professions surround themselves with the history, the literature, and concrete examples of the work with which they may be particularly engaged. Yet it is only in rare instances that such an atmosphere, with its material appurtenances, is to be found in a printing office. Art does not flourish in hidden places, nor under restraint, nor in ignorance of what talent and genius have accomplished and are now accomplishing throughout the world. For to follow precedent wisely does not mean to imitate slavishly one great exemplar, but to study all the masters faithfully, letting their greatest achievements sink slowly into the mind in order that we may patiently derive from

abcdefghijklmnopqrstuvwxy  
ABCDEFGHIJKLMN O PQRSTU VWXYZ  
\$1234567890

10 Point No. 146J, 10 Set

### MONOTYPE FACES

The best kind of originality is that which comes after a sound apprenticeship; that which shall prove to be the blending of a firm conception of all useful precedent and the progressive tendencies of an able mind. For, let a man be as able and original as he may, he cannot afford to discard knowledge of what has gone before or what is now going on in his own trade and profession. If the printers of today do not wish to be esteemed arrogant when they term this calling of theirs an art, they must be willing, and show that they are willing, to subject it to such laws as have made its sister arts so free. All those concerned in what are accepted as the fine arts, the learned sciences and professions, surround themselves with the history, literature, and concrete examples of the work with which they are particularly engaged. Yet it is only in rare instances that such an atmosphere, with its

abcdefghijklmnopqrstuvwxy  
ABCDEFGHIJKLMN O PQRSTU VWXYZ  
\$1234567890

12 Point No. 146J, 12 Set

### MONOTYPE FACES

The best kind of originality is that which comes after a sound apprenticeship; that which shall prove to be the blending of a firm conception of all useful precedent and the progressive tendencies of an able mind. For, let any man be as able and original as he may; he cannot afford to discard knowledge of what has gone before or what is now going on in his own trade and profession. If the printers of today do not wish to be esteemed arrogant when they term this calling of theirs an art, they must be willing, and show that they are willing, to subject it to such laws as have made its sister arts so free. All those concerned in what are accepted as

abcdefghijklmnopqrstuvwxy  
ABCDEFGHIJKLMN O PQRSTU VWXYZ  
\$1234567890

### MONOTYPE FACES

The best kind of originality is that which comes after a sound apprenticeship; that which shall prove to be the blending of a firm conception of all useful precedent and the progressive tendencies of an able mind. For, let any man be as able and original as he may; he cannot afford to discard knowledge of what has gone before or what is now going on in his own trade and profession. If the printers of today do not wish to be esteemed arrogant when they term this calling of theirs an art, they must be willing, and show that they are willing, to subject it to such laws as have made its sister arts so free. All those concerned in what are accepted as the fine arts, and the learned sciences and professions surround themselves with the

14 Point No. 146

**THE "JUST AS GOOD" MACHINE**

Cannot Satisfy the Quality Purchaser of Good Printing who Knows the  
Versatility of the Monotype

**\$1234567890**

18 Point No. 146

**YOUR INVESTMENT IS PROTECTED**

If you don't Handicap yourself with a Machine that can Never be  
Anything but a Type Caster

**\$1234567890**

20 Point No. 146

**INSTALL THE VERSATILE MONOTYPE**

Built on the Unit System, like Filing Cabinets, and just as  
Elastic for Steady Growth

**\$1234567890**

24 Point No. 146

**ASK US TO PROVE OUR CLAIM**

That the Monotype is the Cheapest, because it is the Best  
Type Caster and Composing Machine

**\$1234567890**

30 Point No. 146

**BOTH MOLD AND MACHINE**

Water Cooled to Make Solid Bodies & Smooth Faces

**\$1234567890**

36 Point No. 146

**A PERFECTLY SIMPLE**

Composing Machine: Style D Keyboard

**\$1234567890**

# No. 158J. Job Arrangement C2

## Composition Matrices

5 Point No. 158J, 6½ Set

### MONOTYPE FACES

(This font contains caps, lower case and small caps)

The best kind of originality is that which comes after a sound apprenticeship; that which shall prove to be the blending of a firm conception of all useful precedent and the progressive tendencies of an able mind. For, let a man be as able and original as he may, he cannot afford to discard knowledge of what has gone before or what is now going on in his own trade and profession. If the printers of today do not wish to be esteemed arrogant when they term this calling of theirs an art, they must be willing, and show that they are willing, to subject it to such laws as have made its sister arts so free. All those concerned in what are accepted as the fine arts, the learned sciences and professions, surround themselves with the history,

### MONOTYPE FACES. 5 POINT SMALL CAPS

LITERATURE, AND CONCRETE EXAMPLES OF THE WORK WITH WHICH THEY MAY BE PARTICULARLY ENGAGED. YET IT IS ONLY IN RARE INSTANCES THAT SUCH AN ATMOSPHERE, WITH ITS MATERIAL AFFURTENANCES, IS TO BE FOUND IN A PRINTING OFFICE. ART DOES NOT FLOURISH IN HIDDEN PLACES, NOR

abcdefghijklmnopqrstuvwxyz  
ABCDEFGHIJKLMNOPQRSTUVWXYZ  
\$1234567890  
abcdefghijklmnopqrstuvwxyz  
ABCDEFGHIJKLMNOPQRSTUVWXYZ  
\$1234567890

8 Point No. 158J, 9½ Set

### MONOTYPE FACES

The best kind of originality is that which comes after a sound apprenticeship; that which shall prove to be the blending of a firm conception of all useful precedent and the progressive tendencies of an able mind. For, let a man be as able and original as he may, he cannot afford to discard knowledge of what has gone before or what is now going on in his own trade and profession. If the printers of today do not wish to be esteemed arrogant when they term this calling of theirs an art, they must be willing, and show that they are willing, to subject it to such laws as have made its sister arts so free. All

abcdefghijklmnopqrstuvwxyz  
ABCDEFGHIJKLMNOPQRSTUVWXYZ  
\$1234567890

11 Point No. 158J, 12 Set

### MONOTYPE FACES

The best kind of originality is that which comes after a sound apprenticeship; that which shall prove to be the blending of a firm conception of all useful precedent and the progressive tendencies of an able mind. For, let a man be as able and original as he may, he cannot afford to discard knowledge of what has gone before or what is now going on in his own trade and profession. If the

abcdefghijklmnopqrstuvwxyz  
ABCDEFGHIJKLMNOPQRSTUVWXYZ  
\$1234567890

6 Point No. 158J, 7½ Set

### MONOTYPE FACES

(This font contains caps, lower case and small caps)

The best kind of originality is that which comes after a sound apprenticeship; that which shall prove to be the blending of a firm conception of all useful precedent and the progressive tendencies of an able mind. For, let a man be as able and original as he may, he cannot afford to discard knowledge of what has gone before or what is now going on in his own trade and profession. If the printers of today do not wish to be esteemed arrogant when they term

### MONOTYPE FACES. 6 POINT SMALL CAPS

THIS CALLING OF THEIRS AN ART, THEY MUST BE WILLING, AND SHOW THAT THEY ARE WILLING, TO SUBJECT IT TO SUCH LAWS AS HAVE MADE ITS SISTER ARTS SO FREE. ALL THOSE CONCERNED IN WHAT ARE ACCEPTED AS THE FINE ARTS, THE LEARNED SCIENCES

abcdefghijklmnopqrstuvwxyz  
ABCDEFGHIJKLMNOPQRSTUVWXYZ  
\$1234567890  
abcdefghijklmnopqrstuvwxyz  
ABCDEFGHIJKLMNOPQRSTUVWXYZ  
\$1234567890

10 Point No. 158J, 11 Set

### MONOTYPE FACES

The best kind of originality is that which comes after a sound apprenticeship; that which shall prove to be the blending of a firm conception of all useful precedent and the progressive tendencies of an able mind. For, let any man be as able and original as he may, he cannot afford to discard knowledge of what has gone before or what is now going on in his own trade and profession. If the

abcdefghijklmnopqrstuvwxyz  
ABCDEFGHIJKLMNOPQRSTUVWXYZ  
\$1234567890

12 Point No. 158J, 12½ Set

### MONOTYPE FACES

The best kind of originality is that which comes after a sound apprenticeship; that which shall prove to be the blending of a firm conception of all useful precedent and the progressive tendencies of an able mind. For, let a man be as able and original as he may, he cannot afford to discard a knowledge of what has gone before or what is now going on

abcdefghijklmnopqrstuvwxyz  
ABCDEFGHIJKLMNOPQRSTUVWXYZ  
\$1234567890

14 Point No. 158

**THE DD KEYBOARD**

**A Marvel for Duplicating the Product with One Operating Cost  
A New Field for Greater Profits**

**\$1234567890**

18 Point No. 158

**THE REAL PROFIT**

**On Your Investment is the Selling Price Minus  
Cost of Production**

**\$1234567890**

24 Point No. 158

**THE NEW KEYBOARD**

**It is the only one with a Scientific  
Fingering Arrangement**

**\$1234567890**

30 Point No. 158

**THE TYPE CASTER**

**Can Make Type, Spaces and  
Quads for Job Work**

**\$1234567890**

36 Point No. 158

**MONOTYPERS**

**Maintain High Quality**

**\$1234567890**



# No. 161J. Job Arrangement C2

## Composition Matrices

6 Point No. 161J, 7 Set

### MONOTYPE FACES

The best kind of originality is that which comes after a sound apprenticeship; that which shall prove to be the blending of a firm conception of all useful precedent and the progressive tendencies of an able mind. For, let a man be as able and original as he may, he cannot afford to discard knowledge of what has gone before or what is now going on in his own trade or his profession. If the printers of today do not wish to be esteemed arrogant when they term this calling of theirs an art, they must be willing, and show that they are willing, to subject it to such laws as have made its sister arts so free. All those concerned in what are accepted as the fine arts, the learned sciences, and professions surround themselves with the history, the literature, and concrete examples of the work with which they are particularly engaged. Yet it is only in very rare instances that such an atmosphere, with its material appurtenances, is to be found in a printing office. Art does not flourish in hidden places, nor under restraint, nor in ignorance of what talent and genius have accomplished and are accomplishing throughout the world. For to follow all precedent wisely does

abcdefghijklmnopqrstuvwxyz  
ABCDEFGHIJKLMNOPQRSTUVWXYZ  
\$1234567890

7 Point No. 161J, 8 Set

### MONOTYPE FACES

The best kind of originality is that which comes after a sound apprenticeship; that which shall prove to be the blending of a firm conception of all useful precedent and the progressive tendencies of an able mind. For, let a man be as able and original as he may, he cannot afford to discard knowledge of what has gone before or what is now going on in his own trade and profession. If the printers of today do not wish to be esteemed too arrogant when they term this calling of theirs an art, they must be willing, and show that they are willing, to subject it to such laws as have made its sister arts so free. All those concerned in what are accepted as the fine arts, the learned sciences, and the professions surround themselves with the history, the literature, and concrete examples of the work with which they are particularly engaged. Yet it is only

abcdefghijklmnopqrstuvwxyz  
ABCDEFGHIJKLMNOPQRSTUVWXYZ  
\$1234567890

8 Point No. 161J, 8½ Set

### MONOTYPE FACES

The best kind of originality is that which comes after a thorough apprenticeship; that which shall prove to be the blending of a firm conception of all useful precedent and the progressive tendencies of an able mind. For, let a man be as able and original as he may, he cannot afford to discard knowledge of what has gone before or what is now going on in his own trade or his profession. If the printers of today do not wish to be esteemed arrogant when they term this calling of theirs an art, they must be willing, and show that they are willing, to subject it to such laws as have made its sister arts so free. All those concerned in what are accepted as the fine

abcdefghijklmnopqrstuvwxyz  
ABCDEFGHIJKLMNOPQRSTUVWXYZ  
\$1234567890

10 Point No. 161J, 10 Set

### MONOTYPE FACES

The best kind of originality is that which comes after a thorough apprenticeship; that which shall prove to be the blending of a firm conception of all useful precedent and the progressive tendencies of an able mind. For, let a man be as able and original as he may, he cannot afford to discard knowledge of what has gone before or what is now going on in his own trade and profession. If the printers of today do not wish to be esteemed too arrogant when they term this calling of theirs an art, they must be willing, and show that they are willing, to subject it to such laws as have made its sister arts so free. All those concerned in what are accepted as the fine arts, the learned sciences, and professions surround themselves with the history, literature, and concrete examples of the work with which they are particularly engaged. Yet, it is only in rare instances that such an

abcdefghijklmnopqrstuvwxyz  
ABCDEFGHIJKLMNOPQRSTUVWXYZ  
\$1234567890

12 Point No. 161J, 12 Set

### MONOTYPE FACES

The best kind of originality is that which comes after a sound apprenticeship; that which shall prove to be the blending of a firm conception of all useful precedent and the progressive tendencies of an able mind. For, let a man be as able and original as he may, he cannot afford to discard a knowledge of what has gone before or what is now going on in his own trade and profession. If the printers of today do not wish to be esteemed arrogant when they term this calling of theirs an art, they must be willing, and show that they are willing, to subject it to such laws as have made its sister arts so free.

abcdefghijklmnopqrstuvwxyz  
ABCDEFGHIJKLMNOPQRSTUVWXYZ  
\$1234567890

14 Point No. 161

**MATRIX LIBRARY MEMBERS**

**Keep Fonts on Hand for Use When they Please as Long as They  
Please to Convert Idle Time into Money**

**\$1234567890**

18 Point No. 161

**CHANGE OUR TYPE CASTER**

**Into a Composing Machine when you Need it With-  
out the loss of a Penny**

**\$1234567890**

24 Point No. 161

**THE MONOTYPE KEYBOARD  
Separates Type Setting from Making  
and Casting Type**

**\$1234567890**

30 Point No. 161

**SIMPLE JUSTIFICATION  
The width of each Character is  
Automatically Registered**

**\$1234567890**

36 Point No. 161

**CHANGE THE FACE  
But not Key Arrangement**

**\$1234567890**

# No. 161K. Job Arrangement C2

## Composition Matrices

6 Point No. 161K, 7 Set

### MONOTYPE FACES

*The best kind of originality is that which comes after a sound apprenticeship; that which shall prove to be the blending of a firm conception of all useful precedent and the progressive tendencies of an able mind. For, let a man be as able and original as he may, he cannot afford to discard knowledge of what has gone before or what is now going on in his own trade or his profession. If the printers of today do not wish to be esteemed arrogant when they term this calling of theirs an art, they must be willing, and show that they are willing, to subject it to such laws as have made its sister arts so free. All those concerned in what are accepted as the fine arts, the learned sciences, and professions surround themselves with the history, the literature, and concrete examples of the work with which they are particularly engaged. Yet it is only in very rare instances that such an atmosphere, with its material appurtenances, is to be found in a printing office. Art does not flourish in hidden places, nor under restraint, nor in ignorance of what talent and genius have accomplished and are accomplishing throughout the world. For to follow all precedent wisely does not mean to imitate too slavishly one great exemplar, but to study all masters faithfully, letting their great achievements sink slowly into the mind in order that we may patiently derive from the richness of our acquired knowledge and organized system an attitude of our own. The sprightly minded young man, who with his first business breath projects the new and startling, inevitably becomes tiresome, and is driven to an early disappearance; while the stouter, more solidly endowed student will at least spend as much of his time in avoiding mistakes as in evolving brilliant schemes wherewith to dazzle his contemporaries. The best kind of originality is that which comes after a sound apprenticeship; that which shall prove to*

abcdefghijklmnopqrstuvwxyz  
ABCDEFGHIJKLMNOPQRSTUVWXYZ  
\$1234567890

10 Point No. 161K, 10 Set

### MONOTYPE FACES

*The best kind of originality is that which comes after a thorough apprenticeship; that which shall prove to be the blending of a firm conception of all useful precedent and the progressive tendencies of an able mind. For, let a man be as able and original as he may, he cannot afford to discard knowledge of what has gone before or what is now going on in his own trade and profession. If the printers of today do not wish to be esteemed too arrogant when they term this calling of theirs an art, they must be willing, and show that they are willing, to subject it to such laws as have made its sister arts so free. All those concerned in what are accepted as the fine arts, the learned sciences, and professions surround themselves with the history, literature, and concrete examples of the work with which they are particularly engaged. Yet it is only in rare instances that such an atmosphere, with these material appurtenances, is to be found in the printing office.*

abcdefghijklmnopqrstuvwxyz  
ABCDEFGHIJKLMNOPQRSTUVWXYZ  
\$1234567890

8 Point No. 161K, 8½ Set

### MONOTYPE FACES

*The best kind of originality is that which comes after a thorough apprenticeship; that which shall prove to be the blending of a firm conception of all useful precedent and the progressive tendencies of an able mind. For, let a man be as able and original as he may, he cannot afford to discard knowledge of what has gone before or what is now going on in his own trade or his profession. If the printers of today do not wish to be esteemed arrogant when they term this calling of theirs an art, they must be willing, and show that they are willing, to subject it to such laws as have made its sister arts so free. All those concerned in what are accepted as the fine arts, the learned sciences, and professions surround themselves with the history, the literature, and the concrete examples of the work with which they are particularly engaged. Yet it is only in very rare instances that such an atmosphere, with its material appurtenances, is to be found in a printing office. Art does not flourish in hidden places, nor under restraint, nor in ignorance of what talent and genius have accomplished and are accomplishing throughout the world. For to follow precedent wisely does not mean to imitate slavishly one great exemplar,*

abcdefghijklmnopqrstuvwxyz  
ABCDEFGHIJKLMNOPQRSTUVWXYZ  
\$1234567890

12 Point No. 161K, 12 Set

### MONOTYPE FACES

*The best kind of originality is that which comes after a sound apprenticeship; that which shall prove to be the blending of a firm conception of all useful precedent and the progressive tendencies of an able mind. For, let a man be as able and original as he may, he cannot afford to discard a knowledge of what has gone before or what is now going on in his own trade and profession. If the printers of today do not wish to be esteemed arrogant when they term this calling of theirs an art, they must be willing, and show that they are willing, to subject it to such laws as have made its sister arts so free. All those who are concerned in what*

abcdefghijklmnopqrstuvwxyz  
ABCDEFGHIJKLMNOPQRSTUVWXYZ  
\$1234567890



14 Point No. 162

**THE MONOTYPE**  
Has Never Been Equaled for Quality, Speed, Versatility  
and Economy of Cost Combined  
**\$1234567890**

18 Point No. 162

**OVER 1400 FONTS**  
From Which to Select the Face You Want,  
and Others are Added Constantly  
**\$1234567890**

24 Point No. 162

**THE MATRIX LIBRARY**  
Supplies the Seldom Used Faces  
at a Minimum Cost  
**\$1234567890**

30 Point No. 162

**WHY DISTRIBUTE**  
When New Type is Available  
for Every Job?  
**\$1234567890**

36 Point No. 162

**TABULAR WORK**  
Easy on the Monotype  
**\$1234567890**

No. 231J. Book Arrangement C

Composition Matrices

6 Point No. 231J, 6 Set

MONOTYPE FACES

The best kind of originality is that which comes after a sound apprenticeship; that which shall prove to be the blending of a firm conception of all useful precedent and the progressive tendencies of an able mind. For, let a man be as able and original as he may, he cannot afford to discard knowledge of what has gone before or what is now going on in his own trade and profession. If the printers of today do not wish to be esteemed arrogant when they term this calling of theirs an art, they must be willing, and show that they are willing, to subject it to such laws as have made its sister arts so free. All those concerned in what are accepted as the fine arts, the learned sciences and the professions, surround themselves with the history, literature, and concrete examples of the work with which they are particularly engaged. Yet it is only in rare instances that such an atmosphere, with its material appurtenances, is to be found in a printing office. Art does not flourish in hidden places, nor under restraint, nor in ignorance of what talent and genius have accomplished and are accomplishing throughout the world. For to follow precedent wisely does not mean to imitate slavishly one great exemplar, but to study all masters faithfully, letting their great achievements sink slowly into the mind in order that we may patiently derive from the richness of our acquired knowledge and organized system an attitude of our own. The sprightly minded young man, who with his first business breath projects the new and startling, inevitably becomes tiresome, and is driven to an early disappearance; while the slower, more solidly endowed student, will at least spend as much of his time in avoiding mistakes as in evolving brilliant schemes wherewith to dazzle his contemporaries. The best kind of originality is that which comes after a sound apprenticeship; that which shall prove to be the blending of a firm conception of all useful precedent and the progressive tendencies of an able mind. For, let a man be as able and original as he may, he cannot afford to discard knowledge of what has gone before or what is now going on in his own trade and profession. If the printers of today do not wish to be esteemed arrogant when they term this calling of theirs an art, they must be willing, and show that they are willing, to subject it to such laws as have made its sister arts so free. All those concerned in what are accepted as the fine arts, the learned sciences and professions, surround

abcdefghijklmnopqrstuvwxyz  
ABCDEFGHIJKLMNORSTUVWXYZ  
\$1234567890

8 Point No. 231J, 8 Set

MONOTYPE FACES

The best kind of originality is that which comes after a sound apprenticeship; that which shall prove to be the blending of a firm conception of all useful precedent and the progressive tendencies of an able mind. For, let a man be as able and original as he may, he cannot afford to discard knowledge of what has gone before or what is now going on in his own trade and profession. If the printers of today do not wish to be esteemed arrogant when they term this calling of theirs an art, they must be willing, and show that they are willing, to subject it to such laws as have made its sister arts so free. All those concerned in what are accepted as the fine arts, the learned sciences and the professions, surround themselves with the history, the literature, and concrete examples of the work with which they are particularly engaged. Yet it is only in rare instances that such an atmosphere, with its material appurtenances, is to be found in a printing office. Art does not flourish in hidden places, nor under restraint, nor in ignorance of what talent and genius have accomplished and are accomplishing throughout the world. For to follow precedent wisely does not mean to imitate slavishly one great exemplar, but to study all masters faithfully, letting their great achievements sink slowly into the mind in order that we may patiently derive from the richness of our acquired knowledge and organized system an attitude of our own. The sprightly minded young

abcdefghijklmnopqrstuvwxyz  
ABCDEFGHIJKLMNORSTUVWXYZ  
\$1234567890

10 Point No. 231J, 9 1/2 Set

MONOTYPE FACES

The best kind of originality is that which comes after a sound apprenticeship; that which shall prove to be the blending of a firm conception of all useful precedent and the progressive tendencies of an able mind. For, let a man be as able and original as he may, he cannot afford to discard knowledge of what has gone before or what is now going on in his own trade and profession. If the printers of today do not wish to be esteemed arrogant when they term this calling of theirs an art, they must be willing, and show that they are willing, to subject it to such laws as have made its sister arts so free. All those concerned in what are accepted as the fine arts, the learned sciences and the professions, surround themselves with the history, literature, and concrete examples of the work with which they are particularly engaged. Yet it is only in rare instances that such an atmosphere, with all its material appurtenances, is to be found in a printing office. Art does not flourish in hidden places, nor under restraint, nor in ignorance of what talent and genius have accomplished and are accomplishing throughout the

abcdefghijklmnopqrstuvwxyz  
ABCDEFGHIJKLMNORSTUVWXYZ  
\$1234567890

12 Point No. 231J, 11 Set

MONOTYPE FACES

The best kind of originality is that which comes after a sound apprenticeship; that which shall prove to be the blending of a firm conception of all useful precedent and the progressive tendencies of an able mind. For, let a man be as able and original as he may, he cannot afford to discard knowledge of what has gone before or what is now going on in his own trade and profession. If the printers of today do not wish to be esteemed arrogant when they term this calling of theirs an art; they must be willing, and show that they are willing, to subject it to such laws as have made its sister arts so free. All those concerned in what are accepted as the fine arts, the learned sciences and professions, surround themselves with the history, literature, and concrete examples of the work with which

abcdefghijklmnopqrstuvwxyz  
ABCDEFGHIJKLMNORSTUVWXYZ  
\$1234567890

14 Point No. 231

TO THE ADVERTISING MAN

Your Clients are Critical; You must Keep their Enthusiastic Good Will, and Good Type is Second Only to Good Copy

\$1234567890

18 Point No. 231

IF YOU SPECIFY RIGHT

You are Assured of New Type, with Clear, Sharp Faces and Clean, Readable Presswork

\$1234567890

24 Point No. 231

MONOTYPE AD COMPOSITION

Will Give Your Copy a more Artistic Effect and a Better Finished Product

\$1234567890

30 Point No. 231

ALWAYS AVAILABLE

Suitable Monotype Faces for Every Kind of Advertising Copy

\$1234567890

36 Point No. 231

ARE YOU

Getting the Best Right Now?

\$1234567890

14 Point No. 245

**THE MONOTYPE IS THE ONLY  
Composing Machine that Handles Straight Composition and the Most Intricate  
Tabular Matter with Equal Facility  
\$1234567890**

18 Point No. 245

**THE MONOTYPE NOT ONLY SUPPLIES  
Brand New Type for Every Job, but it also Spaces the Lines and  
Words with Perfect Accuracy  
\$1234567890**

24 Point No. 245

**THE MONOTYPE IS THE ONLY  
Composing Machine that Makes the Work of the  
Hand Compositor Easier  
\$1234567890**

30 Point No. 245

**NEW MONOTYPE MATERIAL  
For Every Form Means the Minimum of  
Expense for the Make-up  
\$1234567890**

36 Point No. 245

**YOUR OPERATOR  
Hits Keys Quicker Than He Winks  
\$1234567890**



Composition Matrices

5 1/2 Point No. 255J, 7 1/2 Set

MONOTYPE FACES

MONOTYPE FACES

The best kind of originality is that which comes after a sound apprenticeship; that which shall prove to be the blending of a firm conception of all useful precedent and the progressive tendencies of an able mind. For, let a man be as able and original as he may, he cannot afford to discard knowledge of what has gone before or what is now going on in his own trade and profession. If the printers of today do not wish to be esteemed arrogant when they term this calling of theirs an art, they must be willing, and show that they are willing, to subject it to such laws as have made its sister arts so free. All those concerned in what are accepted as the fine arts, the learned sciences, and professions surround themselves with the history, the literature, and concrete examples of the work with which they are particularly engaged. Yet it is only in rare instances that such an atmosphere, with its material appurtenances, is to be found in a printing office. Art does not flourish in hidden places, nor under restraint, nor in ignorance of what talent and genius have accomplished and are accomplishing throughout the world. For to follow precedent wisely does not mean to imitate slavishly one great exemplar, but to study all masters faithfully, letting their great achievements sink slowly into the mind in order that we may patiently derive from the richness of our acquired knowledge and organized system an attitude of our own. The sprightly minded young man, who with his first business breath projects the new and startling, inevitably becomes tiresome, and is driven to an early disappearance; while the slower, more solidly endowed student will at least spend as much of his time in avoiding mistakes as in evolving brilliant schemes wherewith to dazzle his contemporaries. The best kind of originality is that which comes after a sound apprenticeship; that which shall prove to be the blending of a firm conception of all useful precedent and the progressive tendencies of an able mind. For, let a man be as able and original as he may, he cannot afford to discard knowledge of what has

The best kind of originality is that which comes after a sound apprenticeship; that which shall prove to be the blending of a firm conception of all useful precedent and the progressive tendencies of an able mind. For, let a man be as able and original as he may, he cannot afford to discard knowledge of what has gone before or what is now going on in his own trade and profession. If the printers of today do not wish to be esteemed arrogant when they term this calling of theirs an art, they must be willing, and show that they are willing, to subject it to such laws as have made its sister arts so free. All those concerned in what are accepted as the fine arts, the learned sciences, and professions surround themselves with the history, the literature, and concrete examples of the work with which they are particularly engaged. Yet it is only in rare instances that such an atmosphere, with its material appurtenances, is to be found in a printing office. Art does not flourish in hidden places, nor under restraint, nor in ignorance of what talent and genius have accomplished and are accomplishing throughout the world. For to follow precedent wisely does not mean to imitate slavishly one great exemplar, but to study all masters faithfully, letting their great achievements sink slowly into the mind in order that we may patiently derive from the richness of our acquired knowledge and organized system an attitude of our own. The sprightly minded young man, who with his first business breath projects the new and startling, inevitably becomes tiresome, and is driven to an early disappearance; while the slower, more solidly endowed student will at least spend as much of his time in avoiding mistakes as in evolving brilliant schemes wherewith to dazzle his contemporaries. The best kind of originality is that which comes after a sound apprenticeship; that which shall prove to be the blending of a firm conception of all useful precedent and the progressive tendencies of an able mind. For, let a man be as able and original as he may, he cannot afford to discard knowledge of what has gone before or what is now going on in his own trade and profession. If the printers of today do not wish to be esteemed arrogant when they term this calling of theirs an art, they must be willing, and show that they are willing, to subject it to such laws as have made its sister arts so free. All those concerned in what are accepted as the fine arts, the learned sciences, and professions surround themselves with the history, the literature, and concrete examples of the work with which they are particularly engaged. Yet it is only in rare instances that such an atmosphere, with its material appurtenances, is to be found in a printing office. Art does not flourish in hidden places, nor under restraint, nor in

abcdefghijklmnopqrstuvwxyz  
 ABCDEFGHIJKLMNOPQRSTUVWXYZ  
 31234567890

# No. 328J. Job Arrangement C2

## Composition Matrices

6 Point No. 328J, 8½ Set

### MONOTYPE FACES

The very best kind of originality is that which comes after a thorough apprenticeship; that which shall prove to be the blending of a firm conception of all useful precedent and the progressive tendencies of an able mind. For, let a man be as able and original as he may, he cannot afford to discard knowledge of what has gone before or what is now going on in his own trade or his profession. If the printers of today do not wish to be esteemed arrogant when they term this calling of theirs an art, they must be willing, and show that they are willing, to subject it to such laws as have made its sister arts so free. All those concerned in what are accepted as the fine arts, the learned sciences and professions surround themselves with the history, the literature, and the concrete examples of the work with which they are particularly engaged. Yet it is only in very rare instances that such an atmosphere, with its material appurtenances, is to be found in a printing office. Art does not flourish in hidden places, nor under restraint, nor in ignorance of what talent and genius have accomplished and are accomplishing throughout the world. For to follow precedent wisely does not mean to imitate slavishly one great exemplar, but to study all masters faithfully, letting their great achievements sink slowly into the mind in order that we may patiently derive from the richness of our acquired knowledge and organized system an attitude of our own. The sprightly minded young man, who with his first business breath projects the

abcdefghijklmnopqrstuvwxyz  
ABCDEFGHIJKLMN O PQRSTU VWXYZ  
\$1234567890

7 Point No. 328J, 9½ Set

### MONOTYPE FACES

The best kind of originality is that which comes after a sound apprenticeship; that which shall prove to be the blending of a firm conception of all useful precedent and the progressive tendencies of an able mind. For, let any man be as able and original as he may, he cannot afford to discard knowledge of what has gone before or what is now going on in his own trade and profession. If the printers of today do not wish to be esteemed too arrogant when they term this calling of theirs an art, they must be willing, and show that they are willing, to subject it to just such laws as have made its sister arts so free. All those concerned in what are accepted as the fine arts, the learned sciences and professions surround themselves with the history, literature, and concrete examples of the work with which they are particularly engaged. Yet it is only in very rare instances that such an atmosphere, with its material appurtenances, is to be found in a printing office. Art does not flourish in hidden places, nor under restraint, nor in ignorance of what talent and genius have accomplished and are accomplishing throughout the world. To follow precedent wisely does not mean to imitate slavishly one great exemplar, but to study

abcdefghijklmnopqrstuvwxyz  
ABCDEFGHIJKLMN O PQRSTU VWXYZ  
\$1234567890

8 Point No. 328J, 9½ Set

### MONOTYPE FACES

The very best kind of originality is that which comes after a sound apprenticeship; that which shall prove to be the blending of a firm conception of all useful precedent and the progressive tendencies of an able mind. For, let a man be as able and original as he may, he cannot afford to discard knowledge of what has gone before or what is now going on in his own trade and profession. If the printers of today do not wish to be esteemed arrogant when they term this calling of theirs an art, they must be willing, and show that they are willing, to subject it to such laws as have made its sister arts so free. All those concerned in what are accepted as the fine arts, the learned sciences and professions, surround themselves with the history, literature, and concrete examples of the work with which they are particularly engaged. Yet it is only in rare instances that such an atmosphere, with its material appurtenances, is to be found in a printing office. Art does not flourish in hidden places, nor under restraint, nor in the

abcdefghijklmnopqrstuvwxyz  
ABCDEFGHIJKLMN O PQRSTU VWXYZ  
\$1234567890

### MONOTYPE FACES

The very best kind of originality is that which comes after a sound apprenticeship; that which shall prove to be the blending of a firm conception of all useful precedent and the progressive tendencies of an able mind. For, let a man be as able and original as he may, he cannot afford to discard knowledge of what has gone before or what is now going on in his own trade and profession. If the printers of today do not wish to be esteemed arrogant when they term this calling of theirs an art, they must be willing, and show that they are willing, to subject it to such laws as have made its sister arts so free. All those concerned in what are accepted as the fine arts, the learned sciences and the professions, surround themselves with the history, literature, and concrete examples of the work with which they are particularly engaged. Yet it is only in rare instances that such an atmosphere, with its material appurtenances, is to be found in a printing office. Art does not flourish in hidden places, nor under restraint, nor in ignorance of what talent and genius have accomplished and are accomplishing throughout the world. For to follow precedent wisely does not mean to imitate slavishly one great exemplar, but to study all masters faithfully, letting their great achievements sink slowly

# No. 48J. Book Arrangement C

## Composition Matrices

5 Point No. 48J, 6 Set

### MONOTYPE FACES

THE BEST KIND OF ORIGINALITY IS THAT WHICH COMES AFTER A SOUND APPRENTICESHIP; THAT WHICH SHALL PROVE TO BE THE BLENDING OF A FIRM CONCEPTION OF ALL USEFUL PRECEDENT AND THE PROGRESSIVE TENDENCIES OF AN ABLE MIND. FOR, LET A MAN BE AS ABLE AND ORIGINAL AS HE MAY, HE CANNOT AFFORD TO DISCARD KNOWLEDGE OF WHAT HAS GONE BEFORE OR WHAT IS NOW GOING ON IN HIS OWN TRADE AND PROFESSION. IF THE PRINTERS OF TODAY DO NOT WISH TO BE ESTEEMED ARROGANT WHEN THEY TERM THIS CALLING OF THEIRS AN ART, THEY MUST BE WILLING, AND SHOW THAT THEY ARE WILLING, TO SUBJECT IT TO SUCH LAWS AS HAVE MADE ITS SISTER ARTS SO FREE. ALL THOSE CONCERNED IN WHAT ARE ACCEPTED AS THE FINE ARTS, THE LEARNED SCIENCES, AND PROFESSIONS SURROUND THEMSELVES WITH THE HISTORY, LITERATURE, AND CONCRETE EXAMPLES OF THE WORK WITH WHICH THEY ARE PARTICULARLY ENGAGED. YET IT IS ONLY IN RARE INSTANCES THAT SUCH AN ATMOSPHERE, WITH ITS MATERIAL APPURTENANCES, IS TO BE FOUND IN A PRINTING OFFICE. ART DOES NOT FLOURISH IN HIDDEN PLACES, NOR UNDER RESTRAINT, NOR IN IGNORANCE OF WHAT TALENT AND GENIUS HAVE ACCOMPLISHED AND ARE ACCOMPLISHING THROUGHOUT THE WORLD. FOR TO FOLLOW ALL PRECEDENT WISELY DOES NOT MEAN TO IMITATE SLAVISHLY ONE GREAT EXEMPLAR, BUT TO STUDY ALL THE MASTERS FAITHFULLY, LETTING THEIR GREAT ACHIEVEMENTS SINK SLOWLY INTO THE MIND IN ORDER THAT WE MAY PATIENTLY DERIVE FROM THE RICHNESS OF OUR ACQUIRED KNOWLEDGE AND ORGANIZED SYSTEM AN ATTITUDE OF OUR OWN. THE SPRIGHTLY MINDED YOUNG MAN, WHO WITH HIS FIRST BUSINESS BREATH PROJECTS THE NEW AND THE STARTLING, INEVITABLY BECOMES TIRESOME, AND IS DRIVEN TO AN EARLY DISAPPEARANCE, WHILE THE SLOWER AND MORE SOLIDLY ENDOWED STUDENT WILL AT LEAST SPEND AS MUCH OF HIS TIME IN AVOIDING A MISTAKE

ABCDEFGHIJKLMNPOQRSTUVWXYZ

\$1234567890

6 Point No. 48J, 7 Set

### MONOTYPE FACES

THE BEST KIND OF ORIGINALITY IS THAT WHICH COMES AFTER A SOUND APPRENTICESHIP; THAT WHICH SHALL PROVE TO BE THE BLENDING OF A FIRM CONCEPTION OF ALL USEFUL PRECEDENT AND THE PROGRESSIVE TENDENCIES OF AN ABLE MIND. FOR, LET A MAN BE AS ABLE AND ORIGINAL AS HE MAY, HE CANNOT AFFORD TO DISCARD KNOWLEDGE OF WHAT HAS GONE BEFORE OR WHAT IS NOW GOING ON IN HIS OWN TRADE AND PROFESSION. IF THE PRINTERS OF TODAY DO NOT WISH TO BE ESTEEMED ARROGANT WHEN THEY TERM THIS CALLING OF THEIRS AN ART, THEY MUST BE WILLING, AND SHOW THAT THEY ARE WILLING, TO SUBJECT IT TO SUCH LAWS AS HAVE MADE ITS SISTER ARTS SO FREE. ALL THOSE CONCERNED IN WHAT ARE ACCEPTED AS THE FINE ARTS, THE LEARNED SCIENCES, AND PROFESSIONS SURROUND THEMSELVES WITH THE HISTORY, LITERATURE, AND CONCRETE EXAMPLES OF THE WORK WITH WHICH THEY ARE PARTICULARLY ENGAGED. YET IT IS ONLY IN RARE INSTANCES THAT SUCH AN ATMOSPHERE, WITH ITS MATERIAL APPURTENANCES, IS TO BE FOUND IN A PRINTING OFFICE. ART DOES NOT FLOURISH IN HIDDEN PLACES, NOR UNDER RESTRAINT, NOR IN IGNORANCE OF WHAT TALENT AND GENIUS HAVE ACCOMPLISHED AND ARE ACCOMPLISHING THROUGHOUT THE WORLD. FOR TO FOLLOW ALL PRECEDENT WISELY DOES NOT MEAN TO IMITATE SLAVISHLY ONE GREAT EXEMPLAR,

ABCDEFGHIJKLMNPOQRSTUVWXYZ

\$1234567890

7 Point No. 48J, 8 Set

### MONOTYPE FACES

THE BEST KIND OF ORIGINALITY IS THAT WHICH COMES AFTER A SOUND APPRENTICESHIP; THAT WHICH SHALL PROVE TO BE THE BLENDING OF A FIRM CONCEPTION OF ALL USEFUL PRECEDENT AND THE PROGRESSIVE TENDENCIES OF AN ABLE MIND. FOR, LET A MAN BE AS ABLE AND ORIGINAL AS HE MAY, HE CANNOT AFFORD TO DISCARD KNOWLEDGE OF WHAT HAS GONE BEFORE OR WHAT IS NOW GOING ON IN HIS OWN TRADE AND PROFESSION. IF THE PRINTERS OF TODAY DO NOT WISH TO BE ESTEEMED TOO ARROGANT WHEN THEY TERM THIS CALLING OF THEIRS AN ART, THEY MUST BE WILLING, AND SHOW THAT THEY ARE WILLING, TO SUBJECT IT TO SUCH LAWS AS HAVE MADE ITS SISTER ARTS SO FREE. ALL THOSE CONCERNED IN WHAT ARE ACCEPTED AS THE FINE ARTS, THE LEARNED SCIENCES, AND PROFESSIONS SURROUND THEMSELVES WITH THE HISTORY, LITERATURE, AND CONCRETE EXAMPLES OF THE WORK WITH WHICH THEY ARE PARTICULARLY ENGAGED. YET IT IS ONLY

ABCDEFGHIJKLMNPOQRSTUVWXYZ

\$1234567890

8 Point No. 48J, 8½ Set

### MONOTYPE FACES

THE BEST KIND OF ORIGINALITY IS THAT WHICH COMES AFTER A SOUND APPRENTICESHIP; THAT WHICH SHALL PROVE TO BE THE BLENDING OF A FIRM CONCEPTION OF ALL USEFUL PRECEDENT AND THE PROGRESSIVE TENDENCIES OF AN ABLE MIND. FOR, LET ANY MAN BE AS ABLE AND ORIGINAL AS HE MAY, HE CANNOT AFFORD TO DISCARD KNOWLEDGE OF WHAT HAS GONE BEFORE OR WHAT IS NOW GOING ON IN HIS OWN TRADE AND PROFESSION. IF THE PRINTERS OF TODAY DO NOT WISH TO BE ESTEEMED ARROGANT WHEN THEY TERM THIS CALLING OF THEIRS AN ART, THEY MUST BE WILLING, AND SHOW THAT THEY ARE WILLING, TO SUBJECT IT TO SUCH LAWS AS HAVE MADE ITS SISTER ARTS SO FREE. ALL THOSE WHO ARE CONCERNED IN WHAT ARE ACCEPTED AS THE FINE ARTS, THE LEARNED SCIENCES, AND PROFESSIONS SURROUND THEMSELVES WITH THE HISTORY, LITERATURE, AND CONCRETE EXAMPLES OF THE WORK WITH WHICH THEY ARE PARTICULARLY ENGAGED. YET IT IS ONLY IN RARE INSTANCES THAT SUCH AN ATMOSPHERE, WITH ITS MATERIAL APPURTENANCES, IS TO BE FOUND IN A PRINTING OFFICE. ART DOES NOT FLOURISH IN HIDDEN PLACES, NOR UNDER RESTRAINT, NOR IN IGNORANCE OF WHAT TALENT AND GENIUS HAVE ACCOMPLISHED AND ARE NOW ACCOMPLISHING THROUGHOUT THE WORLD. FOR TO FOLLOW PRECEDENT WISELY DOES NOT MEAN TO IMITATE SLAVISHLY ONE GREAT EXEMPLAR, BUT TO STUDY ALL MASTERS FAITHFULLY, LETTING THEIR GREAT ACHIEVEMENTS SINK SLOWLY INTO THE MIND IN ORDER THAT WE MAY

ABCDEFGHIJKLMNPOQRSTUVWXYZ

\$1234567890

9 Point No. 48J, 9½ Set

### MONOTYPE FACES

THE BEST KIND OF ORIGINALITY IS THAT WHICH COMES AFTER A SOUND APPRENTICESHIP; THAT WHICH SHALL PROVE TO BE THE BLENDING OF A FIRM CONCEPTION OF ALL USEFUL PRECEDENT AND OF THE PROGRESSIVE TENDENCIES OF AN ABLE MIND. FOR, LET A MAN BE AS ABLE AND ORIGINAL AS HE MAY, HE CANNOT AFFORD TO DISCARD KNOWLEDGE OF WHAT HAS GONE BEFORE OR WHAT IS NOW GOING ON IN HIS OWN TRADE AND HIS PROFESSION. IF THE PRINTERS OF TODAY DO NOT WISH TO BE ESTEEMED ARROGANT WHEN THEY TERM THIS CALLING OF THEIRS AN ART, THEY MUST BE WILLING, AND SHOW THAT THEY ARE WILLING, TO SUBJECT IT TO SUCH LAWS AS HAVE MADE ITS SISTER ARTS SO FREE. ALL THOSE CONCERNED IN WHAT ARE ACCEPTED AS THE FINE ARTS, THE LEARNED SCIENCES, AND PROFESSIONS SURROUND THEMSELVES WITH THE HISTORY, THE LITERATURE, AND CONCRETE EXAMPLES OF THE WORK WITH WHICH THEY ARE PARTICULARLY ENGAGED. YET IT IS ONLY IN RARE INSTANCES THAT SUCH AN ATMOSPHERE, WITH ITS MATERIAL APPURTENANCES, IS TO BE FOUND IN A PRINTING OFFICE. ART DOES NOT FLOURISH IN HIDDEN PLACES, NOR UNDER RESTRAINT, NOR IN IGNORANCE OF WHAT TALENT AND

ABCDEFGHIJKLMNPOQRSTUVWXYZ

\$1234567890

# No. 48J. Book Arrangement C

## Composition Matrices

10 Point No. 48J, 10 Set

### MONOTYPE FACES

THE BEST KIND OF ORIGINALITY IS THAT WHICH COMES AFTER A SOUND APPRENTICESHIP; THAT WHICH SHALL PROVE TO BE THE BLENDING OF A FIRM CONCEPTION OF ALL USEFUL PRECEDENT AND THE PROGRESSIVE TENDENCIES OF AN ABLE MIND. FOR, LET A MAN BE AS ABLE AND ORIGINAL AS HE MAY, HE CANNOT AFFORD TO DISCARD KNOWLEDGE OF WHAT HAS GONE BEFORE OR WHAT IS NOW GOING ON IN HIS OWN TRADE AND PROFESSION. IF THE PRINTERS OF TODAY DO NOT WISH TO BE ESTEEMED ARROGANT WHEN THEY TERM THIS CALLING OF THEIRS AN ART, THEY MUST BE WILLING, AND SHOW THAT THEY ARE WILLING, TO SUBJECT IT TO SUCH LAWS AS HAVE MADE ITS SISTER ARTS SO FREE. ALL THOSE CONCERNED IN WHAT ARE ACCEPTED AS THE FINE ARTS, THE LEARNED SCIENCES, AND PROFESSIONS SURROUND THEMSELVES WITH THE HISTORY, THE LITERATURE, AND CONCRETE EXAMPLES OF THE WORK WITH WHICH THEY ARE PARTICULARLY

ABCDEFGHIJKLMNPOQRSTUVWXYZ

\$1234567890

11 Point No. 48J, 11 Set

### MONOTYPE FACES

THE BEST KIND OF ORIGINALITY IS THAT WHICH COMES AFTER A SOUND APPRENTICESHIP; THAT WHICH SHALL PROVE TO BE THE BLENDING OF A FIRM CONCEPTION OF ALL USEFUL PRECEDENT AND THE PROGRESSIVE TENDENCIES OF AN ABLE MIND. FOR, LET A MAN BE AS ABLE AND ORIGINAL AS HE MAY, HE CANNOT AFFORD TO DISCARD KNOWLEDGE OF WHAT HAS GONE BEFORE OR WHAT IS NOW GOING ON IN HIS OWN TRADE AND PROFESSION. IF THE PRINTERS OF TODAY DO NOT WISH TO BE ESTEEMED ARROGANT WHEN THEY TERM THIS CALLING OF THEIRS AN ART, THEY MUST BE WILLING, AND SHOW THAT THEY ARE WILLING, TO SUBJECT IT TO SUCH LAWS AS HAVE MADE ITS SISTER ARTS SO FREE. ALL THOSE WHO ARE CONCERNED IN WHAT ARE ACCEPTED AS THE FINE ARTS, AND THE

ABCDEFGHIJKLMNPOQRSTUVWXYZ

\$1234567890

12 Point No. 48J, 12 Set

### MONOTYPE FACES

THE BEST KIND OF ORIGINALITY IS THAT WHICH COMES AFTER A SOUND APPRENTICESHIP; THAT WHICH SHALL PROVE TO BE THE BLENDING OF A FIRM CONCEPTION OF ALL USEFUL PRECEDENT AND OF THE PROGRESSIVE TENDENCIES OF AN ABLE MIND. FOR, LET A MAN BE AS ABLE AND ORIGINAL AS HE MAY, HE CANNOT AFFORD TO DISCARD KNOWLEDGE OF WHAT HAS GONE BEFORE OR WHAT IS NOW GOING ON IN HIS OWN TRADE AND PROFESSION. IF THE PRINTERS OF TODAY DO NOT WISH TO BE ESTEEMED ARROGANT WHEN THEY TERM THIS CALLING OF THEIRS AN ART, THEY MUST BE WILLING, AND SHOW THAT THEY ARE WILLING, TO SUBJECT IT TO SUCH LAWS AS HAVE MADE ITS SISTER ARTS SO FREE. ALL THOSE CONCERNED

ABCDEFGHIJKLMNPOQRSTUVWXYZ

\$1234567890

### MONOTYPE FACES

THE BEST KIND OF ORIGINALITY IS THAT WHICH COMES AFTER A SOUND APPRENTICESHIP; THAT WHICH SHALL PROVE TO BE THE BLENDING OF A FIRM CONCEPTION OF ALL USEFUL PRECEDENT AND OF THE PROGRESSIVE TENDENCIES OF AN ABLE MIND. FOR, LET A MAN BE AS ABLE AND ORIGINAL AS HE MAY, HE CANNOT AFFORD TO DISCARD KNOWLEDGE OF WHAT HAS GONE BEFORE OR WHAT IS NOW GOING ON IN HIS OWN TRADE AND PROFESSION. IF THE PRINTERS OF TODAY DO NOT WISH TO BE ESTEEMED ARROGANT WHEN THEY TERM THIS CALLING OF THEIRS AN ART, THEY MUST BE WILLING, AND SHOW THAT THEY ARE WILLING, TO SUBJECT IT TO SUCH LAWS AS HAVE MADE ITS SISTER ARTS SO FREE. ALL THOSE CONCERNED IN WHAT ARE ACCEPTED AS THE FINE ARTS, THE LEARNED SCIENCES, AND PROFESSIONS SURROUND THEMSELVES WITH

# No. 49J: Job Arrangement C1

## Composition Matrices

6 Point No. 49J, 6 Set

### MONOTYPE FACES

The best kind of originality is that which comes after a sound apprenticeship; that which shall prove to be the blending of a firm conception of all useful precedent and the progressive tendencies of an able mind. For, let a man be as able and original as he may, he cannot afford to discard knowledge of what has gone before or what is now going on in his own trade and profession. If the printers of today do not wish to be esteemed arrogant when they term this calling of theirs an art, they must be willing, and show that they are willing, to subject it to such laws as have made its sister arts so free. All those concerned in what are accepted as the fine arts, the learned sciences, and professions surround themselves with the history, literature, and concrete examples of the work with which they are particularly engaged. Yet it is only in rare instances that such an atmosphere, with its material appurtenances, is to be found in a printing office. Art does not flourish in hidden places, nor under restraint, nor in ignorance of what talent and genius have accomplished and are now accomplishing throughout the world. For to follow precedent wisely does not mean to imitate slavishly one great exemplar, but to study all masters faithfully, letting their great achievements sink slowly into the mind in order that we may patiently derive from the richness of our acquired knowledge and organized system an attitude of our own. The sprightly minded young man, who with his first business breath projects the new and startling, inevitably becomes tiresome, and is driven to an early disappearance; while the slower, more solidly endowed student will at least spend as much of his time in avoiding mistakes as in evolving brilliant schemes wherewith to dazzle his contemporaries. The very best kind of originality is that which comes after a sound apprenticeship; that which shall prove to be the blending of a firm conception of all useful precedent and the progressive tendencies of an able mind. For, let a man be as able and original as he may, he cannot afford to discard knowledge of what has gone before or what is now going on in his own trade and profession. If the printers of today do not wish to be esteemed arrogant when they term this calling of theirs an art, they must be willing, and show that they are willing, to subject it to such laws as have made its sister arts so free. All those concerned in what are accepted as the fine arts, the learned sciences, and

abcdefghijklmnopqrstuvwxyz

ABCDEFGHIJKLMNPOQRSTUVWXYZ

\$1234567890

10 Point No. 49J, 10 Set

### MONOTYPE FACES

The best kind of originality is that which comes after a sound apprenticeship; that which shall prove to be the blending of a firm conception of all useful precedent and the progressive tendencies of an able mind. For, let a man be as able and original as he may, he cannot afford to discard knowledge of what has gone before or what is now going on in his own trade and profession. If the printers of today do not wish to be esteemed arrogant when they term this calling of theirs an art, they must be willing, and show that they are willing, to subject it to such laws as have made its sister arts so free. All those concerned in what are accepted as the fine arts, the learned sciences, and professions surround themselves with the history, literature, and concrete examples of the work with which they are particularly engaged. Yet it is only in rare instances that such an atmosphere, with its material appurtenances, is to be found in a printing office. Art does not flourish in hidden places, nor under restraint, nor even in ignorance of what

abcdefghijklmnopqrstuvwxyz

ABCDEFGHIJKLMNPOQRSTUVWXYZ

\$1234567890

8 Point No. 49J, 8 Set

### MONOTYPE FACES

The best kind of originality is that which comes after a sound apprenticeship; that which shall prove itself to be the blending of a firm conception of useful precedent and the progressive tendencies of an able mind. For, let a man be as able and original as he may, he cannot afford to discard knowledge of what has gone before or what is now going on in his own trade and profession. If the printers of today do not wish to be esteemed arrogant when they term this calling of theirs an art, they must be willing, and show that they are willing, to subject it to such laws as have made its sister arts so free. All those concerned in what are accepted as the fine arts, the learned sciences, and professions surround themselves with the history, literature, and concrete examples of the work with which they are particularly engaged. Yet it is only in rare instances that such an atmosphere, with its material appurtenances, is to be found in a printing office. Art does not flourish in hidden places, nor under restraint, nor in ignorance of what talent and genius have accomplished and are accomplishing throughout the world. For to follow precedent wisely does not mean to imitate slavishly one great exemplar, but to study all the masters faithfully, letting their great achievements sink slowly into the mind in order that we may patiently derive from the richness of our acquired knowledge and organized system an attitude of our own. The very

abcdefghijklmnopqrstuvwxyz

ABCDEFGHIJKLMNPOQRSTUVWXYZ

\$1234567890

12 Point No. 49J, 12 Set

### MONOTYPE FACES

The best kind of originality is that which comes after a sound apprenticeship; that which shall prove to be the blending of a firm conception of all useful precedent and the progressive tendencies of an able mind. For, let any man be as able and original as he may, he cannot afford to discard knowledge of what has gone before or what is now going on in his own trade and profession. If the printers of today do not wish to be esteemed too arrogant when they term this calling of theirs an art, they must be willing, and show that they are willing, to subject it to such laws as have made its sister arts so free. All those concerned in what are accepted as the fine arts, the learned sciences and professions, surround them-

abcdefghijklmnopqrstuvwxyz

ABCDEFGHIJKLMNPOQRSTUVWXYZ

\$1234567890

18-Point No. 50

A GREAT VARIETY OF NEWSPAPER HEADING STYLES

May be Designed from Monotype Faces shown in this Specimen Book, and New Ones are Being Added Constantly  
Special Faces May Be Made for Particular Job and Newspaper Printers

\$1234567890

24 Point No. 50

NO JOB IS TOO LARGE OR TOO COMPLEX  
Which Cannot be Handled Profitably and in the Simplest Way on the  
One-Type-at-a-Time Monotype

\$1234567890

30 Point No. 50

THE MONOTYPE PRINTER

Makes in his Own Shop all of the Type, Quads and Spaces he  
Requires. Why don't you do it?

\$1234567890

36 Point No. 50

ANY MONOTYPE WILL CAST TYPE

From Hard Metal with Faces Equal to the Best Foundry Type

\$1234567890

# No. 51J. Job Arrangement C1

## Composition Matrices

6 Point No. 51J, 5 Set

### MONOTYPE FACES

The best kind of originality is that which comes after a sound apprenticeship; that which shall prove to be the blending of a firm conception of all useful precedent and the progressive tendencies of an able mind. For, let a man be as able and original as he may, he cannot afford to discard knowledge of what has gone before or what is now going on in his own trade and profession. If the printers of today do not wish to be esteemed arrogant when they term this calling of theirs an art, they must be willing, and show that they are willing, to subject it to such laws as have made its sister arts so free. All those concerned in what are accepted as the fine arts, the learned sciences and professions, surround themselves with the history, literature, and concrete examples of the work with which they are particularly engaged. Yet it is only in rare instances that such an atmosphere, with its material appurtenances, is to be found in a printing office. Art does not flourish in hidden places, nor under restraint, nor in ignorance of what talent and genius have accomplished and are now accomplishing throughout the world. For to follow precedent wisely does not mean to imitate slavishly one great exemplar, but to study all masters faithfully, letting their great achievements sink slowly into the mind in order that we may patiently derive from the richness of our acquired knowledge and organized system an attitude of our own. The sprightly minded young man, who with his first business breath projects the new and startling, inevitably becomes tiresome, and is driven to an early disappearance; while the slower, more solidly endowed student will at least spend as much of his time in avoiding mistakes as in evolving brilliant schemes wherewith to dazzle his contemporaries. The very best kind of originality is that which comes after a sound apprenticeship; that which shall prove to be the blending of a firm conception of all useful precedent and the progressive tendencies of an able mind. For, let a man be as able and original as he may, he cannot afford to discard knowledge of what has gone before or what is now going on in his own trade and profession. If the printers of today do not wish to be esteemed arrogant when they term this calling of theirs an art, they must be willing, and show that they are willing, to subject it to such laws as have made its sister arts so free. All those concerned in what are accepted as the fine arts, the learned sciences and professions, surround themselves with the history, literature, and concrete examples of the work with which they are particularly engaged. Yet it is only in rare instances that such an atmosphere, with its material appurtenances, is to be found in a printing office. Art does not flourish in hidden places, nor under restraint, nor in ignorance of what talent and genius have accom-

abcdefghijklmnopqrstuvwxyz

ABCDEFGHIJKLMNPOQRSTUVWXYZ

\$1234567890

10 Point No. 51J, 7 Set

### MONOTYPE FACES

The best kind of originality is that which comes after a sound apprenticeship; that which shall prove itself to be the blending of a firm conception of useful precedent and the progressive tendencies of an able mind. For, let a man be as able and original as he may, he cannot afford to discard knowledge of what has gone before or what is now going on in his own trade and profession. If the printers of today do not wish to be esteemed arrogant when they term this calling of theirs an art, they must be willing, and show that they are willing, to subject it to such laws as have made its sister arts so free. All those concerned in what are accepted as the fine arts, the learned sciences and professions; surround themselves with the history, literature, and concrete examples of the work with which they are particularly engaged. Yet it is only in rare instances that such an atmosphere, with its material appurtenances, is to be found in a printing office. Art does not flourish in hidden places, nor under restraint, nor in ignorance of what talent and genius have accomplished and are accomplishing throughout the world. For to follow precedent wisely does not mean to imitate slavishly one great exemplar, but to study all the masters faithfully, letting their great achievements sink slowly into the mind in order that we may patiently derive from the richness of our acquired knowledge and organized system an attitude of our own. The very sprightly minded young man, who with his first business breath projects the new,

abcdefghijklmnopqrstuvwxyz

ABCDEFGHIJKLMNPOQRSTUVWXYZ

\$1234567890

8 Point No. 51J, 6 Set

### MONOTYPE FACES

The best kind of originality is that which comes after a sound apprenticeship; that which shall prove to be the blending of a firm conception of all useful precedent and the progressive tendencies of an able mind. For, let a man be as able and original as he may, he cannot afford to discard knowledge of what has gone before or what is now going on in his own trade and profession. If the printers of today do not wish to be esteemed arrogant when they term this calling of theirs an art, they must be willing, and show that they are willing, to subject it to such laws as have made its sister arts so free. All those concerned in what are accepted as the fine arts, the learned sciences and professions, surround themselves with the history, literature, and concrete examples of the work with which they are particularly engaged. Yet it is only in rare instances that such an atmosphere, with its material appurtenances, is to be found in a printing office. Art does not flourish in hidden places, nor under restraint, nor in ignorance of what talent and genius have accomplished and are now accomplishing throughout the world. For to follow precedent wisely does not mean to imitate slavishly one great exemplar, but to study all masters faithfully, letting their great achievements sink slowly into the mind in order that we may patiently derive from the richness of our acquired knowledge and organized system an attitude of our own. The sprightly minded young man, who with his first business breath projects the new and startling, inevitably becomes tiresome, and is driven to an early disappearance; while the slower, more solidly endowed student will at least spend as much of his time in avoiding mistakes as in evolving brilliant schemes wherewith to dazzle

abcdefghijklmnopqrstuvwxyz

ABCDEFGHIJKLMNPOQRSTUVWXYZ

\$1234567890

12 Point No. 51J, 8 Set

### MONOTYPE FACES

The best kind of originality is that which comes after a sound apprenticeship; that which shall prove itself to be the blending of a firm conception of useful precedent and the progressive tendencies of an able mind. For, let a man be as able and original as he may, he cannot afford to discard knowledge of what has gone before or what is now going on in his own trade and profession. If the printers of today do not wish to be esteemed arrogant when they term this calling of theirs an art, they must be willing, and show that they are willing, to subject it to such laws as have made its sister arts so free. All those concerned in what are accepted as the fine arts, the learned sciences and professions, surround themselves with the history, literature, and concrete examples of the work with which they are particularly engaged. Yet it is only in rare instances that such an atmosphere, with its material appurtenances, is to be found in a printing office. Art does not flourish in hidden places, nor under restraint, nor in ignorance of what talent and genius have accomplished and

abcdefghijklmnopqrstuvwxyz

ABCDEFGHIJKLMNPOQRSTUVWXYZ

\$1234567890

No. 51

Electro Display Matrices

14 Point No. 51

**BY USING THE MONOTYPE TYPE FOUNDRY**

**You Can Wholly Avoid the Expense of Buying, and the Worry of Waiting for Type from the Foundry**  
**\$1234567890**

18 Point No. 51

**PROFITABLE CONTINUOUS PRODUCTION**

**The Maximum of Efficiency can be Attained only by means of the Monotype**  
**\$1234567890**

24 Point No. 51

**CUSTOMERS PRAISE THE PRINTERS**

**Who Improve the Quality of Their Work without Increasing Cost**  
**\$1234567890**

30 Point No. 51

**OUR RECENT IMPROVEMENTS**

**Have Made a Newer and More Serviceable Monotype**  
**\$1234567890**

36 Point No. 51

**NEW KEYBOARD, MOLD, MATRIX**

**Easily Establishes a Record for Improvements**  
**\$1234567890**

36H4 Point No. 51

**THIS POINT SIZE MADE**  
**IN CAPS, FIGURES AND POINTS ONLY**  
**\$1234567890**



Composition Matrices

6 Point No. 52J, 7 Set

MONOTYPE FACES

The best kind of originality is that which comes after a sound apprenticeship; that which shall prove to be the blending of a firm conception of all useful precedent and the progressive tendencies of an able mind. For, let a man be as able and original as he may, he cannot afford to discard knowledge of what has gone before or what is now going on in his own trade or his profession. If the printers of today do not wish to be esteemed arrogant when they term this calling of theirs an art, they must be willing, and show that they are willing, to subject it to such laws as have made its sister arts so free. All those concerned in what are accepted as the fine arts, the learned sciences, and professions surround themselves with the history, the literature, and concrete examples of the work with which they are particularly engaged. Yet it is only in very rare instances that such an atmosphere, with its material appurtenances, is to be found in a printing office. Art does not flourish in hidden places, nor under restraint, nor in ignorance of what talent and genius have accomplished and are accomplishing throughout the world. For to follow all precedent wisely does not mean to imitate too slavishly one great exemplar, but to study all masters faithfully, letting their great achievements sink slowly into the mind in order that we may patiently derive from the richness of our acquired knowledge and organized system an attitude of our own. The sprightly minded young man, who with his first business breath projects the new and startling, inevitably becomes tiresome, and is driven to an early disappearance; while the slower, more solidly endowed student will at least spend as much of his time in avoiding mistakes as in evolving brilliant schemes wherewith to dazzle his contemporaries. The best kind of originality is that which comes after a sound apprenticeship; that which shall prove to

abcdefghijklmnopqrstuvwxyz  
ABCDEFGHIJKLMN~~OP~~QRSTUVWXYZ  
\$1234567890

10 Point No. 52J, 10 Set

MONOTYPE FACES

The best kind of originality is that which comes after a thorough apprenticeship; that which shall prove to be the blending of a firm conception of all useful precedent and the progressive tendencies of an able mind. For, let a man be as able and original as he may, he cannot afford to discard knowledge of what has gone before or what is now going on in his own trade and profession. If the printers of today do not wish to be esteemed too arrogant when they term this calling of theirs an art, they must be willing, and show that they are willing, to subject it to such laws as have made its sister arts so free. All those concerned in what are accepted as the fine arts, the learned sciences, and professions surround themselves with the history, literature, and concrete examples of the work with which they are particularly engaged. Yet it is only in rare instances that such an atmosphere, with these material appurtenances, is to be found in the printing office.

abcdefghijklmnopqrstuvwxyz  
ABCDEFGHIJKLMN~~OP~~QRSTUVWXYZ  
\$1234567890

8 Point No. 52J, 8 1/2 Set

MONOTYPE FACES

The best kind of originality is that which comes after a thorough apprenticeship; that which shall prove to be the blending of a firm conception of all useful precedent and the progressive tendencies of an able mind. For, let a man be as able and original as he may, he cannot afford to discard knowledge of what has gone before or what is now going on in his own trade or his profession. If the printers of today do not wish to be esteemed arrogant when they term this calling of theirs an art, they must be willing, and show that they are willing, to subject it to such laws as have made its sister arts so free. All those concerned in what are accepted as the fine arts, the learned sciences, and professions surround themselves with the history, the literature, and the concrete examples of the work with which they are particularly engaged. Yet it is only in very rare instances that such an atmosphere, with its material appurtenances, is to be found in a printing office. Art does not flourish in hidden places, nor under restraint, nor in ignorance of what talent and genius have accomplished and are accomplishing throughout the world. For to follow precedent wisely does not mean to imitate slavishly one great exemplar,

abcdefghijklmnopqrstuvwxyz  
ABCDEFGHIJKLMN~~OP~~QRSTUVWXYZ  
\$1234567890

12 Point No. 52J, 12 Set

MONOTYPE FACES

The best kind of originality is that which comes after a sound apprenticeship; that which shall prove to be the blending of a firm conception of all useful precedent and the progressive tendencies of an able mind. For, let a man be as able and original as he may, he cannot afford to discard a knowledge of what has gone before or what is now going on in his own trade and profession. If the printers of today do not wish to be esteemed arrogant when they term this calling of theirs an art, they must be willing, and show that they are willing, to subject it to such laws as have made its sister arts so free. All those who are concerned in what

abcdefghijklmnopqrstuvwxyz  
ABCDEFGHIJKLMN~~OP~~QRSTUVWXYZ  
\$1234567890

14 Point No. 52

**THE ONLY ONE IN ITS CLASS**  
**The Only Machine that Makes and Sets its Own Type Ready**  
**to Use for Electrotyping or Press**  
**\$1234567890**

18 Point No. 52

**THE MONOTYPE KEYBOARD**  
**Is the Same as the Scientific or Universal Typewriter**  
**Keyboard in Everyday Use**  
**\$1234567890**

24 Point No. 52

**CASTS ONE TYPE AT A TIME**  
**From an Endless Combination of Matrices**  
**Corrections Hand, Not Machine Made**  
**\$1234567890**

30 Point No. 52

**STANDARDIZATION**  
**Of All Monotype Faces for Type**  
**Line and Body Size**  
**\$1234567890**

36 Point No. 52

**KEY ARRANGEMENT**  
**Is the Simplest yet Devised**  
**\$1234567890**

# No. 66J. Job Arrangement C2

## Composition Matrices

5 Point No. 66J, 6 Set

(This font contains caps, lower case and small caps)

### MONOTYPE FACES

The best kind of originality is that which comes after a sound apprenticeship; that which shall prove to be the blending of a firm conception of all useful precedent and the progressive tendencies of an able mind. For, let a man be as able and original as he may, he cannot afford to discard knowledge of what has gone before or what is now going on in his own trade and profession. If the printers of today do not wish to be esteemed arrogant when they term this calling of theirs an art, they must be willing, and show that they are willing, to subject it to such laws as have made its sister arts so free. All those concerned in what are accepted as the fine arts, the learned sciences, and professions surround themselves with the history, literature, and concrete examples of the work with which they may be particularly engaged. Yet it is only in rare instances that such an atmosphere, with its material appurtenances, is to be found in a printing office.

#### MONOTYPE FACES. 5 POINT SMALL CAPS

PRINTERS OF TODAY DO NOT WISH TO BE ESTEEMED ARROGANT WHEN THEY TERM THIS CALLING OF THEIRS AN ART, THEY MUST BE WILLING, AND SHOW THAT THEY ARE WILLING, TO SUBJECT IT TO SUCH LAWS AS HAVE MADE ITS SISTER ARTS SO FREE. ALL THOSE CONCERNED IN WHAT ARE ACCEPTED AS THE FINE ARTS, THE LEARNED SCIENCES, AND PROFESSIONS SURROUND THEMSELVES WITH THE HISTORY, LITERATURE, AND CONCRETE EXAMPLES OF THE WORK WITH WHICH THEY ARE PARTICULARLY ENGAGED. YET IT IS ONLY IN RARE INSTANCES THAT SUCH AN ATMOSPHERE, WITH

abcdefghijklmnopqrstuvwxyz  
ABCDEFGHIJKLMNOPQRSTUVWXYZ  
\$1234567890

abcdefghijklmnopqrstuvwxyz  
ABCDEFGHIJKLMNOPQRSTUVWXYZ  
\$1234567890

6 Point No. 66J, 7 Set

### MONOTYPE FACES

The best kind of originality is that which comes after a sound apprenticeship; that which shall prove to be the blending of a firm conception of all useful precedent and the progressive tendencies of an able mind. For, let a man be as able and original as he may, he cannot afford to discard knowledge of what has gone before or what is now going on in his own trade or his profession. If the printers of today do not wish to be esteemed arrogant when they term this calling of theirs an art, they must be willing, and show that they are willing, to subject it to such laws as have made its sister arts so free. All those concerned in what are accepted as the fine arts, the learned sciences, and professions surround themselves with the history, the literature, and concrete examples of the work with which they are particularly engaged. Yet it is only in very rare instances that such an atmosphere, with its material appurtenances, is to be found in a printing office. Art does not flourish in hidden places, nor under restraint, nor in ignorance of what talent and genius have accomplished and are accomplishing throughout the world. For to follow all precedent wisely does

abcdefghijklmnopqrstuvwxyz  
ABCDEFGHIJKLMNOPQRSTUVWXYZ  
\$1234567890

8 Point No. 66J, 8 Set

### MONOTYPE FACES

The best kind of originality is that which comes after a thorough apprenticeship; that which shall prove to be the blending of a firm conception of all useful precedent and the progressive tendencies of an able mind. For, let a man be as able and original as he may, he cannot afford to discard knowledge of what has gone before or what is now going on in his own trade or his profession. If the printers of today do not wish to be esteemed too arrogant when they term this calling of theirs an art, they must be willing, and show that they are willing, to subject it to such laws as have made its sister arts so free. All those concerned in what are accepted as the fine

abcdefghijklmnopqrstuvwxyz  
ABCDEFGHIJKLMNOPQRSTUVWXYZ  
\$1234567890

10 Point No. 66J, 10 Set

### MONOTYPE FACES

The best kind of originality is that which comes after a sound apprenticeship; that which shall prove to be the blending of a firm conception of all useful precedent and the progressive tendencies of an able mind. For, let a man be as able and original as he may, he cannot afford to discard knowledge of what has gone before or what is now going on in his own trade and profession. If the printers of today do not wish to be esteemed too arrogant when they term this calling of theirs an art, they must be willing, and show that they are willing, to subject it to just such laws as have made its sister arts so free. All those concerned in what are accepted as the fine arts, the learned sciences, and professions surround themselves with the history, literature, and concrete examples of the work with which they are particu-

abcdefghijklmnopqrstuvwxyz  
ABCDEFGHIJKLMNOPQRSTUVWXYZ  
\$1234567890

12 Point No. 66J, 12 Set

### MONOTYPE FACES

The best kind of originality is that which comes after a sound apprenticeship; that which shall prove to be the blending of a firm conception of all useful precedent and the progressive tendencies of an able mind. For, let a man be as able and original as he may, he cannot afford to discard knowledge of what has gone before or what is now going on in his own trade or his profession. If the printers of today do not wish to be esteemed arrogant when they term this calling of theirs an art, they must be willing, and show that they are willing, to subject it to such laws as have made its sister

abcdefghijklmnopqrstuvwxyz  
ABCDEFGHIJKLMNOPQRSTUVWXYZ  
\$1234567890

14 Point No. 66

**OLD FAMILIAR FACES**  
**Are a Pleasure to the Eye of the Printer. They are the**  
**Friends of Long Ago**  
**\$1234567890**

18 Point No. 66

**BUT THE SAME, OLD FACES**  
**Will not Attract Work to Your Shop or Help You**  
**Out in the Pressroom**  
**\$1234567890**

24 Point No. 66

**NEW OLD FACES**  
**Give Your Pressmen a Perpetual Picnic**  
**on the Makeready**  
**\$1234567890**

30 Point No. 66

**ALWAYS NEW**  
**True in Body and Face. That's**  
**the Monotype Way**  
**\$1234567890**

36 Point No. 66

**DON'T DELAY**  
**It Means a Step Backward**  
**\$1234567890**

# No. 77J. Job Arrangement C1

## Composition Matrices

6 Point No. 77J, 5 Set

### MONOTYPE FACES

The best kind of originality is that which comes after a sound apprenticeship; that which shall prove to be the blending of a firm conception of all useful precedent and the progressive tendencies of an able mind. For, let a man be as able and original as he may, he cannot afford to discard knowledge of what has gone before or what is now going on in his own trade and profession. If the printers of today do not wish to be esteemed arrogant when they term this calling of theirs an art, they must be willing, and show that they are willing, to subject it to such laws as have made its sister arts so free. All those concerned in what are accepted as the fine arts, the learned sciences, and professions surround themselves with the history, literature, and concrete examples of the work with which they are particularly engaged. Yet it is only in rare instances that such an atmosphere, with its material appurtenances, is to be found in a printing office. Art does not flourish in hidden places, nor under restraint, nor in ignorance of what talent and genius have accomplished and are now accomplishing throughout the world. For to follow precedent wisely does not mean to imitate slavishly one great exemplar, but to study all masters faithfully, letting their great achievements sink slowly into the mind in order that we may patiently derive from the richness of our acquired knowledge and organized system an attitude of our own. The sprightly minded young man, who with his first business breath projects the new and startling, inevitably becomes throwaway, and is driven to an early disappearance; while the slower, more softly endowed student will at least spend as much of his time in avoiding mistakes as in evolving brilliant schemes wherewith to dazzle his contemporaries. The best kind of originality is that which comes after a sound apprenticeship; that which shall prove to be the blending of a firm conception of all useful precedent and the progressive tendencies of an able mind. For, let a man be as able and original as he may, he cannot afford to discard knowledge of what has gone before or what is now going on in his own trade and profession. If the printers of today do not wish to be esteemed arrogant when they term this calling of theirs an art, they must be willing, and show that they are willing, to subject it to such laws as have made its sister arts so free. All those concerned in what are accepted as the fine arts, the learned sciences, and professions surround themselves with the history, literature, and concrete examples of the work with which they are particularly engaged. Yet it is only in rare instances that such an atmosphere, with its material appurtenances, is to be found in a printing office. Art does not flourish in hidden places, nor under restraint, nor in ignorance of what talent and genius have accomplished and are now accomplishing throughout the world. For to follow precedent wisely does not mean to imitate slavishly one great exemplar, but to study all masters faithfully, letting

abcdefghijklmnopqrstuvwxyz  
 ABCDEFGHIJKLMNOPQRSTUVWXYZ  
 \$1234567890

10 Point No. 77J, 8 Set

### MONOTYPE FACES

The best kind of originality is that which comes after a sound apprenticeship; that which shall prove to be the blending of a firm conception of all useful precedent and the progressive tendencies of an able mind. For, let a man be as able and original as he may, he cannot afford to discard knowledge of what has gone before or what is now going on in his own trade and profession. If the printers of today do not wish to be esteemed arrogant when they term this calling of theirs an art, they must be willing, and show that they are willing, to subject it to such laws as have made its sister arts so free. All those concerned in what are accepted as the fine arts, the learned sciences, and professions surround themselves with the history, literature, and concrete examples of the work with which they are particularly engaged. Yet it is only in rare instances that such an atmosphere, with its material appurtenances, is to be found in a printing office. Art does not flourish in hidden places, nor under restraint, nor in ignorance of what talent and genius have accomplished and are now accomplishing throughout the world. For to follow precedent wisely does not mean to imitate slavishly one great exemplar, but to study all masters faithfully, letting their great achievements sink slowly into the

abcdefghijklmnopqrstuvwxyz  
 ABCDEFGHIJKLMNOPQRSTUVWXYZ  
 \$1234567890

8 Point No. 77J, 6 1/2 Set

### MONOTYPE FACES

The best kind of originality is that which comes after a sound apprenticeship; that which shall prove to be the blending of a firm conception of all useful precedent and the progressive tendencies of an able mind. For, let a man be as able and original as he may, he cannot afford to discard knowledge of what has gone before or what is now going on in his own trade and profession. If the printers of today do not wish to be esteemed arrogant when they term this calling of theirs an art, they must be willing, and show that they are willing, to subject it to such laws as have made its sister arts so free. All those concerned in what are accepted as the fine arts, the learned sciences, and professions surround themselves with the history, literature, and concrete examples of the work with which they are particularly engaged. Yet it is only in rare instances that such an atmosphere, with its material appurtenances, is to be found in a printing office. Art does not flourish in hidden places, nor under restraint, nor in ignorance of what talent and genius have accomplished and are accomplishing throughout the world. For to follow precedent wisely does not mean to imitate slavishly one great exemplar, but to study all masters faithfully, letting their great achievements sink slowly into the mind in order that we may patiently derive from the richness of our acquired knowledge and organized system an attitude of our own. The sprightly minded young man, who with his first business breath projects the new and startling, inevitably becomes throwaway, and is driven to an early disappearance; while the slower, more softly endowed student will at least spend as much of his time in avoiding mistakes as in evolving brilliant schemes wherewith

abcdefghijklmnopqrstuvwxyz  
 ABCDEFGHIJKLMNOPQRSTUVWXYZ  
 \$234567890

12 Point No. 77J, 9 1/2 Set

### MONOTYPE FACES

The best kind of originality is that which comes after a sound apprenticeship; that which shall prove to be the blending of a firm conception of all useful precedent and the progressive tendencies of an able mind. For, let a man be as able and original as he may, he cannot afford to discard knowledge of what has gone before or what is now going on in his own trade and profession. If the printers of today do not wish to be esteemed arrogant when they term this calling of theirs an art, they must be willing, and show that they are willing, to subject it to such laws as have made its sister arts so free. All those concerned in what are accepted as the fine arts, the learned sciences, and professions surround themselves with the history, literature, and concrete examples of the work with which they are particularly engaged. Yet it is only in rare instances that such an atmosphere, with its material appurtenances,

abcdefghijklmnopqrstuvwxyz  
 ABCDEFGHIJKLMNOPQRSTUVWXYZ  
 \$1234567890

14 Point No. 77

**YOU ARE NOT TYING UP MACHINERY**  
Waiting for Author's and Proofreader's Proofs if you have a Monotype Equipment.  
The Monotype can be kept busy every working hour on profitable work.  
**\$1234567890**

18 Point No. 77

**THERE IS NOTHING TOO DIFFICULT**  
For the Monotype Operator. If it can be set by hand the Monotype  
can do it; do it quickly, and at great saving in cost  
**\$1234567890**

24 Point No. 77

**IF BUSINESS IS SLACK**  
Fill Your Cases With Display Type And Spacing Material.  
Get Ready for the Rush to Come  
**\$1234567890**

30 Point No. 77

**ANY SERIES OF TYPE**  
Required in Quantity Can Be Renewed in a Few  
Hours With The Type Caster  
**\$1234567890**

36 Point No. 77

**OPPORTUNITY MAY KNOCK**  
But the Live Ones Buy the Monotype  
**\$1234567890**

# No. 107J. Job Arrangement C2

## Composition Matrices

5 Point No. 107J, 6 Set

### MONOTYPE FACES

The best kind of originality is that which comes after a sound apprenticeship; that which shall prove to be the blending of a firm conception of all useful precedent and the progressive tendencies of an able mind. For, let a man be as able and original as he may, he cannot afford to discard knowledge of what has gone before or what is now going on in his own trade and profession. If the printers of today do not wish to be esteemed arrogant when they term this calling of theirs an art, they must be willing, and show that they are willing, to subject it to such laws as have made its sister arts so free. All those concerned in what are accepted as the fine arts, the learned sciences, and professions surround themselves with the history, literature, and concrete examples of the work with which they may be particularly engaged. Yet it is only in rare instances that such an atmosphere, with its material appurtenances, is to be found in a printing office. Art does not flourish in hidden places, nor under restraint, nor even in ignorance of what talent and genius have accomplished and are accom-

abcdefghijklmnopqrstuvwxyz  
ABCDEFGHIJKLMN O PQRSTU VWXYZ  
\$1234567890

7 Point No. 107J, 8 Set

### MONOTYPE FACES

The best kind of originality is that which comes after a sound apprenticeship; that which shall prove to be the blending of a firm conception of all useful precedent and the progressive tendencies of an able mind. For, let a man be as able and original as he may, he cannot afford to discard knowledge of what has gone before or what is now going on in his own trade and profession. If the printers of today do not wish to be esteemed arrogant when they term this calling of theirs an art, they must be willing, and show that they are willing, to subject it to such laws as have made its sister arts so free. All those concerned in what are accepted as the fine arts, the learned sciences, and professions, surround themselves with the history, literature, and concrete examples of the work with which they are particularly

abcdefghijklmnopqrstuvwxyz  
ABCDEFGHIJKLMN O PQRSTU VWXYZ  
\$1234567890

10 Point No. 107J, 10 Set

### MONOTYPE FACES

The best kind of originality is that which comes after a sound apprenticeship; that which shall prove to be the blending of a firm conception of all useful precedent and the progressive tendencies of an able mind. For, let a man be as able and original as he may, he cannot afford to discard knowledge of what has gone before or what is now going on in his own trade and profession. If the printers of today do not wish to be esteemed arrogant when they term this calling of theirs an art, they must be willing, and show that they are willing, to subject it to such laws as have made its sister arts so free. All those concerned in what are accepted as the fine arts, the learned sciences, and profes-

abcdefghijklmnopqrstuvwxyz  
ABCDEFGHIJKLMN O PQRSTU VWXYZ  
\$1234567890

6 Point No. 107J, 7 Set

### MONOTYPE FACES

The best kind of originality is that which comes after a sound apprenticeship; that which shall prove to be the blending of a firm conception of all useful precedent and the progressive tendencies of an able mind. For, let a man be as able and original as he may, he cannot afford to discard knowledge of what has gone before or what is now going on in his own trade and profession. If the printers of today do not wish to be esteemed arrogant when they term this calling of theirs an art, they must be willing, and show that they are willing, to subject it to such laws as have made its sister arts so free. All those concerned in what are accepted as the fine arts, the learned sciences, and professions surround themselves with the

abcdefghijklmnopqrstuvwxyz  
ABCDEFGHIJKLMN O PQRSTU VWXYZ  
\$1234567890

8 Point No. 107J, 8 1/2 Set

### MONOTYPE FACES

The best kind of originality is that which comes after a sound apprenticeship; that which shall prove to be the blending of a firm conception of all useful precedent and the progressive tendencies of an able mind. For, let a man be as able and original as he may, he cannot afford to discard knowledge of what has gone before or what is now going on in his own trade and profession. If the printers of today do not wish to be esteemed arrogant when they term this calling of theirs an art, they must be willing, and show that they are willing, to subject it to such laws as have made its sister arts so free. All those concerned in what are accepted as the fine

abcdefghijklmnopqrstuvwxyz  
ABCDEFGHIJKLMN O PQRSTU VWXYZ  
\$1234567890

12 Point No. 107J, 12 Set

### MONOTYPE FACES

The best kind of originality is that which comes after a sound apprenticeship; that which shall prove to be the blending of a firm conception of all useful precedent and the progressive tendencies of an able mind. For, let a man be as able and original as he may, he cannot afford to discard a knowledge of what has gone before or what is now going on in his own trade and profession. If the printers of today do not wish to be esteemed arrogant when they term

abcdefghijklmnopqrstuvwxyz  
ABCDEFGHIJKLMN O PQRSTU VWX  
\$1234567890

14 Point No. 107

**THE STANDARD OF QUALITY  
Is Monotype, Commanding a Higher Price than any other kind  
of Machine Composition  
\$1234567890**

18 Point No. 107

**THE BEST MAGAZINES  
And Knowing Purchasers of Printing everywhere  
Say Use the Monotype  
\$1234567890**

24 Point No. 107

**GOOD TYPOGRAPHY  
Will Boost the Price for You and Sell  
the Product at a Profit  
\$1234567890**

30 Point No. 107

**HEIGHT TO PAPER  
Accuracy of Monotype Type will  
Save Make-Ready  
\$1234567890**

36 Point No. 107

**NEWSPAPER ADS.  
Set Like Straight Matter  
\$1234567890**



THE DAILY NEWSPAPER OR JOB PRINTING OFFICE WITHOUT A MONOTYPE IS FAR FROM A STATE OF IDEAL EFFICIENCY  
\$1234567890

ALL COSTLY ERRORS IN ADVERTISING THROUGH WORN-OUT TYPE ARE ENDED FOREVER IN THE MONOTYPE SHOP  
\$1234567890

DISPLAY TYPE CAN BE CAST IN ANY QUANTITY CHEAPER THAN IT CAN BE DISTRIBUTED  
\$1234567890

AND THE APPEARANCE OF THE PAPER WILL BE INCREASED 100 PER CENT.  
\$1234567890

14 Point No. 129

**IF YOU NEVER MADE MISTAKES  
And Your Cost Sheets Always Showed a Good Margin of Profit  
on Every Job in the Composing Room  
\$1234567890**

18 Point No. 129

**IF YOUR EMPLOYEES  
Could Easily Set Eight Thousand Ems or More  
Per Hour by Hand  
\$1234567890**

24 Point No. 129

**IF TYPE WAS ALWAYS NEW  
And Never Became Battered and Worn  
by too Frequent Use  
\$1234567890**

30 Point No. 129

**MONOTYPE MACHINES  
Would Not Be Needed Until the  
Millennium Had Passed  
\$1234567890**

36 Point No. 129

**UNTIL THEN  
You Will Need a Monotype  
\$1234567890**

# No. 132K. Job Arrangement C2

## Composition Matrices

6 Point No. 132K, 7½ Set

### MONOTYPE FACES

*The best kind of originality is that which comes after a sound apprenticeship; that which shall prove to be the blending of a firm conception of all useful precedent and the progressive tendencies of an able mind. For, let a man be as able and original as he may, he cannot afford to discard knowledge of what has gone before or what is now going on in his own trade and profession. If the printers of today do not wish to be esteemed arrogant when they term this calling of theirs an art, they must be willing, and show that they are willing, to subject it to such laws as have made its sister arts so free. All those concerned in what are accepted as the fine arts, the learned sciences, and professions surround themselves with the history, literature, and concrete examples of the work with which they are particularly engaged. Yet it is only in rare instances that such an atmosphere, with its material appurtenances, is to be found in a printing office. Art does not flourish in hidden places, nor under restraint, nor in ignorance of what talent and genius have accomplished and are accomplishing throughout the world. For to follow precedent wisely does not mean to imitate slavishly one great exemplar, but to study all masters faithfully, letting their great achievements sink slowly into the mind in order that we may patiently derive from the richness of our acquired knowledge and organized system an attitude of our own. The sprightly minded young man who with his first business breath projects the new and startling, inevitably becomes tiresome, and is driven to an early disappearance; while the slower, more solidly endowed student will at least spend as much of his time in avoiding mistakes as in evolving brilliant schemes wherewith to dazzle his contemporaries.*

abcdefghijklmnopqrstuvwxyz  
ABCDEFGHIJKLMN OPQRSTUVWXYZ  
\$1234567890

8 Point No. 132K, 9 Set

### MONOTYPE FACES

*The best kind of originality is that which comes after a sound apprenticeship; that which shall prove to be the blending of a firm conception of all useful precedent and of the progressive tendencies of an able mind. For, let a man be as able and original as he may, he cannot afford to discard knowledge of what has gone before or what is now going on in his own trade and profession. If the printers of today do not wish to be esteemed arrogant when they term this calling of theirs an art, they must be willing, and show that they are willing, to subject it to such laws as have made its sister arts so free. All those concerned in what are accepted as the fine arts, the learned sciences, and professions surround themselves with the history, the literature and concrete examples of the work with which they are particularly engaged. Yet it is only in rare instances that such an atmosphere, with its material appurtenances, is to be found in a printing office. Art does not flourish in hidden places, nor under restraint, nor in ignorance of what talent and genius have accomplished and are accomplishing throughout the world. For*

abcdefghijklmnopqrstuvwxyz  
ABCDEFGHIJKLMN OPQRSTUVWXYZ  
\$1234567890

10 Point No. 132K, 11 Set

### MONOTYPE FACES

*The very best kind of originality is that which comes after a sound apprenticeship; that which shall prove itself to be the blending of a firm conception of all useful precedent and the progressive tendencies of an able mind. For, let a man be as able and as original as he may, he cannot afford to discard all knowledge of what has gone before or of what is now going on in his own trade and profession. If the printers of today do not wish to be esteemed arrogant when they term this calling of theirs an art, they must be willing, and show that they are willing, to subject it to such laws as have made its sister arts so free. All those concerned in what are accepted as the fine arts, the learned sciences, and professions surround themselves with the history, the literature, and concrete examples of the work with which they are particularly engaged. Yet it is only in*

abcdefghijklmnopqrstuvwxyz  
ABCDEFGHIJKLMN OPQRSTUVWXYZ  
\$1234567890

12 Point No. 132K, 12½ Set

### MONOTYPE FACES

*The best kind of originality is that which comes after a sound apprenticeship; that which shall prove to be the blending of a firm conception of all useful precedent and the progressive tendencies of a clever mind. For, let any man be as able and original as he may, he cannot afford to discard a knowledge of what has gone before or what is now going on in his own trade and profession. If the printers of today do not wish to be esteemed arrogant when they term this calling of theirs an art, they must be willing, and show that they are willing, to subject it to such laws as have made its sister arts so free. All those who*

abcdefghijklmnopqrstuvwxyz  
ABCDEFGHIJKLMN OPQRSTUVWXYZ  
\$1234567890

# No. 140J. Job Arrangement C1

## Composition Matrices

6 Point No. 140J, 5 Set

### MONOTYPE FACES

The best kind of originality is that which comes after a sound apprenticeship; that which shall prove to be the blending of a firm conception of all useful precedent and the progressive tendencies of an able mind. For, let a man be as able and original as he may, he cannot afford to discard knowledge of what has gone before or what is now going on in his own trade and profession. If the printers of today do not wish to be esteemed arrogant when they term this calling of theirs an art, they must be willing, and show that they are willing, to subject it to such laws as have made its sister arts so free. All those concerned in what are accepted as the fine arts, the learned sciences, and professions surround themselves with the history, literature, and concrete examples of the work with which they are particularly engaged. Yet it is only in rare instances that such an atmosphere with its material appurtenances, is to be found in a printing office. Art does not flourish in hidden places, nor under restraint, nor in ignorance of what talent and genius have accomplished and are now accomplishing throughout the world. For to follow precedent wisely does not mean to imitate slavishly one great exemplar, but to study all masters faithfully, letting their great achievements sink slowly into the mind in order that we may patiently derive from the richness of our acquired knowledge and organized system an attitude of our own. The sprightly minded young man, who with his first business breath projects the new and startling, inevitably becomes tiresome, and is driven to an early disappearance; while the slower, more solidly endowed student will at least spend as much of his time in avoiding mistakes as in evolving brilliant schemes wherewith to dazzle his contemporaries. The best kind of originality is that which comes after a sound apprenticeship; that which shall prove to be the blending of a firm conception of all useful precedent and the progressive tendencies of an able mind. For, let a man be as able and original as he may, he cannot afford to discard knowledge of what has gone before or what is now going on in his own trade and profession. If the printers of today do not wish to be esteemed arrogant when they term this calling of theirs an art, they must be willing, and show that they are willing, to subject it to such laws as have made its sister arts so free. All those concerned in what are accepted as the fine arts, the learned sciences, and professions surround themselves with the history, literature, and concrete examples of the work with which they are particularly engaged. Yet it is only in rare instances that such an atmosphere, with its material appurtenances, is to be found in a printing office. Art does not flourish in hidden places, nor under restraint, nor in ignorance of what talent and genius have accomplished and are now accomplishing throughout the world. For to follow precedent wisely does not mean to imitate slavishly one great exemplar, but to study all masters faithfully, letting

abcdefghijklmnopqrstuvwxyz

ABCDEFGHIJKLMN OPQRSTUVWXYZ

\$1234567890

10 Point No. 140J, 8 Set

### MONOTYPE FACES

The best kind of originality is that which comes after a sound apprenticeship; that which shall prove to be the blending of a firm conception of all useful precedent and the progressive tendencies of an able mind. For, let a man be as able and original as he may, he cannot afford to discard knowledge of what has gone before or what is now going on in his own trade and profession. If the printers of today do not wish to be esteemed arrogant when they term this calling of theirs an art, they must be willing, and show that they are willing, to subject it to such laws as have made its sister arts so free. All those concerned in what are accepted as the fine arts, the learned sciences, and professions surround themselves with the history, literature, and concrete examples of the work with which they are particularly engaged. Yet it is only in rare instances that such an atmosphere, with its material appurtenances, is to be found in a printing office. Art does not flourish in hidden places, nor under restraint, nor in ignorance of what talent and genius have accomplished and are now accomplishing throughout the world. For to follow precedent wisely does not mean to imitate slavishly one great exemplar, but to study all masters faithfully, letting their great achievements sink slowly into the

abcdefghijklmnopqrstuvwxyz

ABCDEFGHIJKLMN OPQRSTUVWXYZ

\$1234567890

8 Point No. 140J, 6 1/2 Set

### MONOTYPE FACES

The best kind of originality is that which comes after a sound apprenticeship; that which shall prove to be the blending of a firm conception of all useful precedent and the progressive tendencies of an able mind. For, let a man be as able and original as he may, he cannot afford to discard knowledge of what has gone before or what is now going on in his own trade and profession. If the printers of today do not wish to be esteemed arrogant when they term this calling of theirs an art, they must be willing, and show that they are willing, to subject it to such laws as have made its sister arts so free. All those concerned in what are accepted as the fine arts, the learned sciences, and professions surround themselves with the history, literature, and concrete examples of the work with which they are particularly engaged. Yet it is only in rare instances that such an atmosphere, with its material appurtenances, is to be found in a printing office. Art does not flourish in hidden places, nor under restraint, nor in ignorance of what talent and genius have accomplished and are now accomplishing throughout the world. For to follow precedent wisely does not mean to imitate slavishly one great exemplar, but to study all masters faithfully, letting their great achievements sink slowly into the mind in order that we may patiently derive from the richness of our acquired knowledge and organized system an attitude of our own. The sprightly minded young man, who with his first business breath projects the new and startling, inevitably becomes tiresome, and is driven to an early disappearance; while the slower, more solidly endowed student will at least spend as much of his time in avoiding mistakes as in evolving brilliant schemes wherewith

abcdefghijklmnopqrstuvwxyz

ABCDEFGHIJKLMN OPQRSTUVWXYZ

\$1234567890

12 Point No. 140J, 9 1/2 Set

### MONOTYPE FACES

The best kind of originality is that which comes after a sound apprenticeship; that which shall prove to be the blending of a firm conception of all useful precedent and the progressive tendencies of an able mind. For, let a man be as able and original as he may, he cannot afford to discard knowledge of what has gone before or what is now going on in his own trade and profession. If the printers of today do not wish to be esteemed arrogant when they term this calling of theirs an art, they must be willing, and show that they are willing, to subject it to such laws as have made its sister arts so free. All those concerned in what are accepted as the fine arts, the learned sciences, and professions surround themselves with the history, literature, and concrete examples of the work with which they are particularly engaged. Yet it is only in rare instances that such an atmosphere, with its material appurtenances, is to be found in a

abcdefghijklmnopqrstuvwxyz

ABCDEFGHIJKLMN OPQRSTUVWXYZ

\$1234567890

14 Point No. 140

**YOU CAN SAVE THE DOLLARS AND CENTS  
Spent in Turning Letters and Waiting for Sorts. The Profit is Yours on both Body and  
Display Type if you Use the Monotype  
\$1234567890**

18 Point No. 140

**STOP THE LEAK OF IDLE TIME  
No Machine is Worth Having when you Can't Run it as an Actual  
Producer on Live Copy all the Time  
\$1234567890**

24 Point No. 140

**A MAXIMUM OF REAL RUNNING HOURS  
You can Run the Monotype More Hours a Year than any  
other Composing Machine  
\$1234567890**

30 Point No. 140

**A NEW PRODUCT FOR EACH JOB  
Monotype Type better than Foundry Type  
unless new type is used for Every job  
\$1234567890**

36 Point No. 140

**TYPE ON TAP ALL THE TIME  
Can't get out of Sorts with Monotype  
\$1234567890**

# No. 149J. Job Arrangement C1

## Composition Matrices

5½ Point No. 149J, 6 Set

### MONOTYPE FACES

The best kind of originality is that which comes after a sound apprenticeship; that which shall prove to be the blending of a firm conception of all useful precedent and the progressive tendencies of an able mind. For, let a man be as able and original as he may, he cannot afford to discard knowledge of what has gone before or what is now going on in his own trade and profession. If the printers of today do not wish to be esteemed arrogant when they term this calling of theirs an art, they must be willing, and show that they are willing, to subject it to such laws as have made its sister arts so free. All those concerned in what are accepted as the fine arts, the learned sciences and professions, surround themselves with the history, literature, and concrete examples of the work with which they are particularly engaged. Yet it is only in rare instances that such an atmosphere, with its material appurtenances, is to be found in a printing office. Art does not flourish in hidden places, nor under restraint, nor in ignorance of what talent and genius have accomplished and are now accomplishing throughout the world. For to follow precedent wisely does not mean to imitate slavishly one great exemplar, but to study all masters faithfully, letting their great achievements sink slowly into the mind in order that we may patiently derive from the richness of our acquired knowledge and organized system an attitude of our own. The sprightly minded young man, who with his first business breath projects the new

abcdefghijklmnopqrstuvwxyz  
ABCDEFGHIJKLMNOPQRSTUVWXYZ  
\$1234567890

6 Point No. 149J, 6½ Set

### MONOTYPE FACES

The best kind of originality is that which comes after a sound apprenticeship; that which shall prove to be the blending of a firm conception of all useful precedent and the progressive tendencies of an able mind. For, let a man be as able and original as he may, he cannot afford to discard knowledge of what has gone before or what is now going on in his own trade and profession. If the printers of today do not wish to be esteemed arrogant when they term this calling of theirs an art, they must be willing, and show that they are willing, to subject it to such laws as have made its sister arts so free. All those concerned in what are accepted as the fine arts, the learned sciences and professions, surround themselves with the history, literature, and concrete examples of the work with which they are particularly engaged. Yet it is only in rare instances that such an atmosphere, with its material appurtenances, is to be found in a printing office. Art does not flourish in hidden places, nor under restraint, nor in ignorance of what talent and genius have accomplished and are accomplishing throughout the world. For to follow precedent wisely does not mean to imitate slavishly one great exemplar, but to study all masters faithfully, letting their great achievements sink slowly into the mind in order that we may patiently derive from the richness of our acquired knowl-

abcdefghijklmnopqrstuvwxyz  
ABCDEFGHIJKLMNOPQRSTUVWXYZ  
\$1234567890

8 Point No. 149J, 8½ Set

### MONOTYPE FACES

The best kind of originality is that which comes after a sound apprenticeship; that which shall prove to be the blending of a firm conception of all useful precedent and the progressive tendencies of an able mind. For, let a man be as able and original as he may, he cannot afford to discard knowledge of what has gone before or what is now going on in his own trade and profession. If the printers of today do not wish to be esteemed arrogant when they term this calling of theirs an art, they must be willing, and show that they are willing, to subject it to such laws as have made its sister arts so free. All those concerned in what are accepted as the fine arts, the learned sciences and professions, surround themselves with the history, the literature, and concrete examples of the work

abcdefghijklmnopqrstuvwxyz  
ABCDEFGHIJKLMNOPQRSTUVWXYZ  
\$1234567890

10 Point No. 149J, 10 Set

### MONOTYPE FACES

The best kind of originality is that which comes after a sound apprenticeship; that which shall prove to be the blending of a firm conception of all useful precedent and the progressive tendencies of an able mind. For, let a man be as able and original as he may, he cannot afford to discard knowledge of what has gone before or what is now going on in his own trade and profession. If the printers of today do not wish to be esteemed arrogant when they term this calling of theirs an art, they must be willing, and show that they are willing, to subject it to such laws as have made its sister arts so free. All those concerned in what are accepted as the fine arts, the learned sciences and professions, surround themselves with the history, literature, and concrete examples of the work with which they are particularly engaged. Yet it is only in rare instances that such an atmosphere, with its material appurtenances, is to be found in the

abcdefghijklmnopqrstuvwxyz  
ABCDEFGHIJKLMNOPQRSTUVWXYZ  
\$1234567890

12 Point No. 149J, 12 Set

### MONOTYPE FACES

The best kind of originality is that which comes after a sound apprenticeship; that which shall prove to be the blending of a firm conception of all useful precedent and the progressive tendencies of an able mind. For, let any man be as able and original as he may, he cannot afford to discard knowledge of what has gone before or what is now going on in his own trade and profession. If the printers of today do not wish to be esteemed arrogant when they term this calling of theirs an art, they must be willing, and show that they are willing, to subject it to such laws as have made its sister arts so free. All those concerned in what are accepted as

abcdefghijklmnopqrstuvwxyz  
ABCDEFGHIJKLMNOPQRSTUVWXYZ  
\$1234567890

# No. 165J. Job Arrangement C2

## Composition Matrices

### 5 Point No. 165J, 6 Set

(This font contains caps and small caps)

#### MONOTYPE FACES. 5 POINT CAPS

THE BEST KIND OF ORIGINALITY IS THAT WHICH COMES AFTER A SOUND APPRENTICESHIP; THAT WHICH SHALL PROVE TO BE THE BLENDING OF A FIRM CONCEPTION OF ALL USEFUL PRECEDENT AND THE PROGRESSIVE TENDENCIES OF AN ABLE MIND. FOR, LET A MAN BE AS ABLE AND ORIGINAL AS HE MAY, HE CANNOT AFFORD TO DISCARD KNOWLEDGE OF WHAT HAS GONE BEFORE OR WHAT IS NOW GOING ON IN HIS OWN TRADE AND PROFESSION. IF THE PRINTERS OF TODAY DO NOT WISH TO BE ESTEEMED ARROGANT WHEN THEY TERM THIS CALLING OF THEIRS AN ART, THEY MUST BE WILLING, AND SHOW THAT THEY ARE WILLING, TO SUBJECT IT

#### MONOTYPE FACES. 5 POINT SMALL CAPS

TO SUCH LAWS AS HAVE MADE ITS SISTER ARTS SO FREE. ALL THOSE CONCERNED IN WHAT ARE ACCEPTED AS THE FINE ARTS, THE LEARNED SCIENCES, AND PROFESSIONS SURROUND THEMSELVES WITH THE HISTORY, LITERATURE, AND CONCRETE EXAMPLES OF THE WORK WITH WHICH THEY ARE PARTICULARLY ENGAGED. YET IT IS ONLY IN RARE INSTANCES THAT SUCH AN ATMOSPHERE, WITH ITS MATERIAL APPURTENANCES, IS TO BE FOUND IN A PRINTING OFFICE. ART DOES NOT FLOURISH IN HIDDEN PLACES NOR UNDER RESTRAINT, NOR IN IGNORANCE OF WHAT TALENT AND GENIUS ACCOMPLISHED AND ARE ACCOMPLISHING THROUGHOUT THE WORLD. FOR TO FOLLOW ALL

#### MONOTYPE FACES. 5 POINT CAPS AND SMALL CAPS

PRECEDENT WISELY DOES NOT MEAN TO IMITATE SLAVISHLY ONE GREAT EXEMPLAR, BUT TO STUDY ALL THE MASTERS FAITHFULLY, LETTING THEIR GREAT ACHIEVEMENTS SINK SLOWLY INTO THE MIND IN ORDER THAT WE MAY PATIENTLY DERIVE FROM THE RICHNESS OF OUR ACQUIRED KNOWLEDGE AND ORGANIZED SYSTEM AN ATTITUDE OF OUR OWN. THE SPRIGHTLY MINDED YOUNG MAN, WHO WITH HIS FIRST BUSINESS BREATH PROJECTS THE NEW AND STARTLING, INVENTIVELY BECOMES TIRESOME, AND IS DRIVEN TO AN EARLY DISAPPEARANCE; WHILE THE SLOWER AND MORE SOLIDLY ENDOWED STUDENT WILL AT LEAST SPEND AS MUCH OF HIS TIME IN AVOIDING A MISTAKE AS IN EVOLVING A BRILLIANT SCHEME WHEREWITH TO DAZZLE HIS CONTEMPORARIES. THE BEST KIND OF ORIGINALITY IS THAT WHICH COMES AFTER A SOUND APPRENTICESHIP; THAT WHICH SHALL PROVE TO BE THE BLENDING OF A FIRM CONCEPTION OF ALL USEFUL PRECEDENT

ABCDEFGHIJKLMNORSTUVWXYZ  
\$1234567890

ABCDEFGHIJKLMNORSTUVWXYZ  
\$1234567890

### 6 Point No. 165J, 7 Set

#### MONOTYPE FACES

THE BEST KIND OF ORIGINALITY IS THAT WHICH COMES AFTER A SOUND APPRENTICESHIP; THAT WHICH SHALL PROVE TO BE THE BLENDING OF A FIRM CONCEPTION OF ALL USEFUL PRECEDENT AND THE PROGRESSIVE TENDENCIES OF AN ABLE MIND. FOR, LET ANY MAN BE AS ABLE AND ORIGINAL AS HE MAY, HE CANNOT AFFORD TO DISCARD KNOWLEDGE OF WHAT HAS GONE BEFORE OR WHAT IS NOW GOING ON IN HIS OWN TRADE AND PROFESSION. IF THE PRINTERS OF TODAY DO NOT WISH TO BE ESTEEMED ARROGANT WHEN THEY TERM THIS CALLING OF THEIRS AN ART, THEY MUST BE WILLING, AND SHOW THAT THEY ARE WILLING, TO SUBJECT IT TO SUCH LAWS AS HAVE MADE ITS SISTER ARTS SO FREE. ALL THOSE WHO ARE CONCERNED IN WHAT ARE ACCEPTED AS THE FINE ARTS, THE LEARNED SCIENCES, AND PROFESSIONS SURROUND THEMSELVES WITH THE HISTORY, LITERATURE, AND CONCRETE EXAMPLES OF THE WORK WITH WHICH THEY ARE PARTICULARLY ENGAGED. YET IT IS ONLY IN RARE INSTANCES THAT SUCH AN ATMOSPHERE, WITH ITS MATERIAL APPURTENANCES, IS TO BE FOUND IN A PRINTING OFFICE. ART DOES NOT FLOURISH IN HIDDEN PLACES, NOR UNDER RESTRAINT, NOR IN IGNORANCE OF WHAT TALENT AND GENIUS HAVE ACCOMPLISHED AND ARE NOW ACCOMPLISHING THROUGHOUT THE WORLD. FOR TO FOLLOW PRECEDENT WISELY DOES NOT MEAN TO IMITATE SLAVISHLY ONE GREAT EXEMPLAR, BUT TO STUDY ALL MASTERS FAITHFULLY, LETTING THEIR GREAT ACHIEVEMENTS SINK SLOWLY INTO THE MIND IN ORDER THAT WE MAY PATIENTLY DERIVE FROM THE RICHNESS OF OUR ACQUIRED KNOWLEDGE AND ORGANIZED SYSTEM AN ATTITUDE OF OUR OWN. THE SPRIGHTLY MINDED YOUNG MAN, WHO WITH HIS FIRST BUSINESS BREATH PROJECTS THE NEW AND

ABCDEFGHIJKLMNORSTUVWXYZ  
\$1234567890

### 8 Point No. 165J, 8 1/2 Set

#### MONOTYPE FACES

THE BEST KIND OF ORIGINALITY IS THAT WHICH COMES AFTER A SOUND APPRENTICESHIP; THAT WHICH SHALL PROVE TO BE THE BLENDING OF A FIRM CONCEPTION OF ALL USEFUL PRECEDENT AND OF THE PROGRESSIVE TENDENCIES OF AN ABLE MIND. FOR, LET A MAN BE AS ABLE AND ORIGINAL AS HE MAY, HE CANNOT AFFORD TO DISCARD KNOWLEDGE OF WHAT HAS GONE BEFORE OR WHAT IS NOW GOING ON IN HIS OWN TRADE AND HIS PROFESSION. IF THE PRINTERS OF TODAY DO NOT WISH TO BE ESTEEMED ARROGANT WHEN THEY TERM THIS CALLING OF THEIRS AN ART, THEY MUST BE WILLING, AND SHOW THAT THEY ARE WILLING, TO SUBJECT IT TO SUCH LAWS AS HAVE MADE ITS SISTER ARTS SO FREE. ALL THOSE CONCERNED IN WHAT ARE ACCEPTED AS THE FINE ARTS, THE LEARNED SCIENCES, AND PROFESSIONS SURROUND THEMSELVES WITH THE HISTORY, THE LITERATURE, AND CONCRETE EXAMPLES OF THE WORK WITH WHICH THEY ARE PARTICULARLY ENGAGED. YET IT IS ONLY IN RARE INSTANCES THAT SUCH AN ATMOSPHERE, WITH ITS MATERIAL APPURTENANCES, IS TO BE FOUND IN A PRINTING OFFICE. ART DOES NOT FLOURISH IN HIDDEN PLACES, NOR UNDER RESTRAINT, NOR IN IGNORANCE OF WHAT TALENT AND GENIUS HAVE

ABCDEFGHIJKLMNORSTUVWXYZ  
\$1234567890

### 9 Point No. 165J, 9 1/2 Set

#### MONOTYPE FACES

THE BEST KIND OF ORIGINALITY IS THAT WHICH COMES AFTER A SOUND APPRENTICESHIP; THAT WHICH SHALL PROVE TO BE THE BLENDING OF A FIRM CONCEPTION OF ALL USEFUL PRECEDENT AND OF THE PROGRESSIVE TENDENCIES OF AN ABLE MIND. FOR, LET A MAN BE AS ABLE AND ORIGINAL AS HE MAY, HE CANNOT AFFORD TO DISCARD KNOWLEDGE OF WHAT HAS GONE BEFORE OR WHAT IS NOW GOING ON IN HIS OWN TRADE AND HIS PROFESSION. IF THE PRINTERS OF TODAY DO NOT WISH TO BE ESTEEMED ARROGANT WHEN THEY TERM THIS CALLING OF THEIRS AN ART, THEY MUST BE WILLING, AND SHOW THAT THEY ARE WILLING, TO SUBJECT IT TO SUCH LAWS AS HAVE MADE ITS SISTER ARTS SO FREE. ALL THOSE CONCERNED IN WHAT ARE ACCEPTED AS THE FINE ARTS, THE LEARNED SCIENCES, AND THE PROFESSIONS SURROUND THEMSELVES WITH THE HISTORY, THE LITERATURE, AND CONCRETE EXAMPLES OF THE WORK WITH WHICH THEY ARE PARTICULARLY ENGAGED. YET IT IS ONLY IN A

ABCDEFGHIJKLMNORSTUVWXYZ  
\$1234567890

**No. 165J. Job Arrangement C2**

**Composition Matrices**

10 Point No. 165J, 10½ Set

**MONOTYPE FACES**

THE BEST KIND OF ORIGINALITY IS THAT WHICH COMES AFTER A SOUND APPRENTICESHIP; THE KIND WHICH SHALL PROVE TO BE THE BLENDING OF A FIRM CONCEPTION OF ALL USEFUL PRECEDENT AND THE PROGRESSIVE TENDENCIES OF AN ABLE MIND. FOR, LET A MAN BE AS ABLE AND ORIGINAL AS HE MAY, HE CANNOT AFFORD TO DISCARD KNOWLEDGE OF WHAT HAS GONE BEFORE OR WHAT IS NOW GOING ON IN HIS OWN TRADE AND PROFESSION. IF THE PRINTERS OF TODAY DO NOT DESIRE TO BE ESTEEMED ARROGANT WHEN THEY TERM THIS CALLING OF THEIRS AN ART, THEY MUST BE WILLING, AND SHOW THAT THEY ARE WILLING, TO SUBJECT IT TO SUCH LAWS AS HAVE MADE ITS SISTER ARTS SO FREE. ALL THOSE CONCERNED IN WHAT ARE ACCEPTED AS THE FINE ARTS, THE LEARNED SCIENCES, AND PROFESSIONS SURROUND THEMSELVES WITH

ABCDEFGHIJKLMNOPQRSTUVWXYZ  
\$1234567890

12 Point No. 165J, 12½ Set

**MONOTYPE FACES**

THE BEST KIND OF ORIGINALITY IS THAT WHICH COMES AFTER A SOUND APPRENTICESHIP; THE KIND WHICH SHALL PROVE TO BE THE BLENDING OF A FIRM CONCEPTION OF ALL USEFUL PRECEDENT AND THE PROGRESSIVE TENDENCIES OF AN ABLE MIND. FOR, LET ANY MAN BE AS ABLE AND ORIGINAL AS HE MAY, HE CANNOT WELL AFFORD TO DISCARD KNOWLEDGE OF WHAT HAS GONE BEFORE OR WHAT IS NOW GOING ON IN HIS OWN TRADE AND PROFESSION. IF THE PRINTERS OF TODAY DO NOT WISH TO BE ESTEEMED ARROGANT WHEN THEY TERM THIS CALLING OF THEIRS AN ART, THEY MUST BE

ABCDEFGHIJKLMNOPQRSTUVWXYZ  
\$1234567890

**No. 165**

**Electro Display Matrices**

14 Point No. 165

**NON-DISTRIBUTION**

**AND THE MONOTYPE MEANS HAVING EVERYTHING YOU WANT WHEN YOU WANT IT**

**\$1234567890**

18 Point No. 165

**QUALITY MAINTAINED**

**AT LESS COST WHEN YOU USE NEW TYPE FOR EVERY JOB**

**\$1234567890**



# No. 176J. Job Arrangement C1

## Composition Matrices

6 Point No. 176J, 6 Set

### MONOTYPE FACES

The best kind of originality is that which comes after a sound apprenticeship; that which shall prove to be the blending of a firm conception of all useful precedent and the progressive tendencies of an able mind. For, let a man be as able and original as he may, he cannot afford to discard knowledge of what has gone before or what is now going on in his own trade and profession. If the printers of today do not wish to be esteemed arrogant when they term this calling of theirs an art, they must be willing, and show that they are willing, to subject it to such laws as have made its sister arts so free. All those concerned in what are accepted as the fine arts, the learned sciences, and professions surround themselves with the history, literature, and concrete examples of the work with which they are particularly engaged. Yet it is only in rare instances that such an atmosphere, with its material appurtenances, is to be found in a printing office. Art does not flourish in hidden places, nor under restraint, nor in ignorance of what talent and genius have accomplished and we are now accomplishing throughout the world. For to follow precedent wisely does not mean to imitate slavishly one great exemplar, but to study all the masters faithfully, letting their great achievements sink slowly into the mind in order that we may patiently derive from the richness of our acquired knowledge and organized system an attitude of our own. The sprightly minded young man, who with his first business breath projects the new and startling, inevitably becomes tiresome, and is driven to an early disappearance; while the slower, more solidly endowed student will at least spend as much of his time in avoiding mistakes as in evolving brilliant schemes wherewith to dazzle his contemporaries. The very best kind of originality is that which comes after a sound apprenticeship; that which shall prove to be the blending of a firm conception of all useful precedent and the progressive tendencies of an able mind. For, let a man be as able and original as he may, he cannot afford to discard knowledge of what has gone before or what is now going on in his own trade and profession. If the printers of today do not wish to be esteemed arrogant when they term this calling of theirs an art, they must be willing, and show that they are willing, to subject it to such laws as have made its sister arts so free. All those concerned in what are accepted as the fine arts, the learned sciences, and professions surround

abcdefghijklmnopqrstuvwxyz

ABCDEFGHIJKLMNOPQRSTUVWXYZ

\$1234567890

16 Point No. 176J, 8 1/2 Set

### MONOTYPE FACES

The best kind of originality is that which comes after a sound apprenticeship; that which shall prove to be the blending of a firm conception of all useful precedent and the progressive tendencies of an able mind. For, let a man be as able and original as he may, he cannot afford to discard knowledge of what has gone before or what is now going on in his own trade and profession. If the printers of today do not wish to be esteemed arrogant when they term this calling of theirs an art, they must be willing, and show that they are willing, to subject it to such laws as have made its sister arts so free. All those concerned in what are accepted as the fine arts, the learned sciences, and professions surround themselves with the history, literature, and concrete examples of the work, with which they may be particularly engaged. Yet it is only in rare instances that such an atmosphere, with its material appurtenances, is to be found in a printing office. Art does not flourish in hidden places, nor under restraint, nor in ignorance of what talent and genius have accomplished and are now accomplishing throughout the world. For to follow precedent wisely does not mean to imitate slavishly one great exemplar, but to study all the masters

abcdefghijklmnopqrstuvwxyz

ABCDEFGHIJKLMNOPQRSTUVWXYZ

\$1234567890

6 Point No. 176J, 7 Set

### MONOTYPE FACES

The best kind of originality is that which comes after a sound apprenticeship; that which shall prove itself to be the blending of a firm conception of useful precedent and the progressive tendencies of an able mind. For, let a man be as able and original as he may, he cannot afford to discard knowledge of what has gone before or what is now going on in his own trade and profession. If the printers of today do not wish to be esteemed arrogant when they term this calling of theirs an art, they must be willing, and show that they are willing, to subject it to such laws as have made its sister arts so free. All those concerned in what are accepted as the fine arts, the learned sciences, and professions surround themselves with the history, literature, and concrete examples of the work with which they are particularly engaged. Yet it is only in rare instances that such an atmosphere, with its material appurtenances, is to be found in a printing office. Art does not flourish in hidden places, nor under restraint, nor in ignorance of what talent and genius have accomplished and are accomplishing throughout the world. For to follow precedent wisely does not mean to imitate slavishly one great exemplar, but to study all masters faithfully, letting their great achievements sink slowly into the mind in order that we may patiently derive from the richness of our acquired knowledge and organized system an attitude of our own. The sprightly minded young man, who with his first business breath projects the new and startling, inevitably becomes tiresome, and is driven to an early disappearance; while the slower, more solidly endowed student will at least spend as

abcdefghijklmnopqrstuvwxyz

ABCDEFGHIJKLMNOPQRSTUVWXYZ

\$1234567890

12 Point No. 176J, 10 Set

### MONOTYPE FACES

The best kind of originality is that which comes after a sound apprenticeship; that which shall prove to be the blending of a firm conception of all useful precedent and the progressive tendencies of an able mind. For, let a man be as able and original as he may, he cannot afford to discard knowledge of what has gone before or what is now going on in his own trade and profession. If the printers of today do not wish to be esteemed arrogant when they term this calling of theirs an art, they must be willing, and show that they are willing, to subject it to such laws as have made its sister arts so free. All those concerned in what are accepted as the fine arts, the learned sciences and professions, surround themselves with the history, literature, and concrete examples of the work with which they are particularly engaged. Yet it is only in

abcdefghijklmnopqrstuvwxyz

ABCDEFGHIJKLMNOPQRSTUVWXYZ

\$1234567890

14 Point No. 176

**THE MONOTYPE IS BUILT IN PHILADELPHIA**  
And is used Everywhere by Profit-making Printers on all Kinds of Work. Quality  
and Quantity, with Economy, is the Monotype Way  
**\$1234567890**

18 Point No. 176

**MONOTYPE COMPOSITION**  
Costs less by Comparison than the Product of any other Type-  
setting or Composing Machine  
**\$1234567890**

24 Point No. 176

**IF YOU WISH TO BE SHOWN**  
Investigate the Qualifications of the Monotype.  
You will be Fully Convinced  
**\$1234567890**

30 Point No. 176

**MONOTYPE USERS SAY**  
That our Claims are much Under the Real  
Merits of the Versatile Machine  
**\$1234567890**

36 Point No. 176

**MONOTYPE VALUE**  
Being Proved Daily in Every Office  
**\$1234567890**

# No. 204J. Job Arrangement C4

## Composition Matrices

5 Point No. 204J, 5 Set

### MONOTYPE FACES

The best kind of originality is that which comes after a sound apprenticeship; that which shall prove to be the blending of a firm conception of all useful precedent and the progressive tendencies of an able mind. For, let a man be as able and original as he may, he cannot afford to discard knowledge of what has gone before or what is now going on in his own trade and profession. If the printers of today do not wish to be esteemed arrogant when they term this calling of theirs an art, they must be willing, and show that they are willing, to subject it to such laws as have made its sister arts so free. All those concerned in what are accepted as the fine arts, the learned sciences and the professions, surround themselves with the history, literature, and the concrete examples of the work with which they are particularly engaged. Yet it is only in rare instances that such an atmosphere, with its material appurtenances, is to be found in a printing office. Art does not flourish in hidden places, nor under restraint, nor in ignorance of what talent and genius have accomplished and are accomplishing throughout the world. For to follow precedent wisely does not mean to imitate slavishly one great exemplar, but to study all masters faithfully, letting their great achievements sink slowly into the mind in order that we may patiently derive from the richness of our acquired knowledge and organized system an attitude of our own. The sprightly minded young man, who with his first business breath projects the new and startling, inevitably becomes tiresome, and is driven to an early disappearance; while the slower, more solidly endowed student, will at least spend as much of his time in avoiding mistakes as in evolving brilliant schemes wherewith to dazzle his contemporaries. The best kind of originality is that which comes after a sound apprenticeship; that which shall prove to be the blending of a firm conception of all useful precedent and the progressive tendencies of an able mind. For, let any man be as able and as original as he may, he cannot afford to discard knowledge of what has gone before or what is now going on in his own trade and profession. If the printers of today do not wish to be esteemed arrogant when they term this calling of theirs an art, they must be willing, and show that they are willing, to subject it to such laws as have made its sister arts so free. All those concerned in what are now accepted as the fine arts, the learned sciences and the professions, surround themselves with the history, literature, and the

abcdefghijklmnopqrstuvwxyz  
ABCDEFGHIJKLMNPOQRSTUVWXYZ  
\$1234567890

6 Point No. 204J, 6 Set

### MONOTYPE FACES

The best kind of originality is that which comes after a sound apprenticeship; that which shall prove to be the blending of a firm conception of all useful precedent and the progressive tendencies of an able mind. For, let a man be as able and original as he may, he cannot afford to discard knowledge of what has gone before or what is now going on in his own trade and profession. If the printers of today do not wish to be esteemed arrogant when they term this calling of theirs an art, they must be willing, and show that they are willing, to subject it to such laws as have made its sister arts so free. All those concerned in what are accepted as the fine arts, the learned sciences and the professions, surround themselves with the history, literature, and concrete examples of the work with which they are particularly engaged. Yet it is only in rare instances that such an atmosphere, with its material appurtenances, is to be found in a printing office. Art does not flourish in hidden places nor under restraint, nor in ignorance of what talent and genius have accomplished and are accomplishing throughout the world. For to follow precedent wisely does not mean to imitate slavishly one great exemplar, but to study all masters faithfully, letting their great achievements sink slowly into the mind in order that we may patiently derive from the richness of our acquired knowledge and organized system an attitude of our own. The sprightly minded young man, who with his first business breath projects the new and startling, inevitably becomes tiresome, and is driven to an early disappearance; while the slower, more solidly endowed student will at least spend as much of his time in

abcdefghijklmnopqrstuvwxyz  
ABCDEFGHIJKLMNPOQRSTUVWXYZ  
\$1234567890

8 Point No. 204J, 7 Set

### MONOTYPE FACES

The best kind of originality is that which comes after a sound apprenticeship; that which shall prove to be the blending of a firm conception of all useful precedent and the progressive tendencies of an able mind. For, let a man be as able and original as he may, he cannot afford to discard knowledge of what has gone before or what is now going on in his own trade and profession. If the printers of today do not wish to be esteemed arrogant when they term this calling of theirs an art, they must be willing, and show that they are willing, to subject it to such laws as have made its sister arts so free. All those concerned in what are accepted as the fine arts, the learned sciences and the professions, surround themselves with the history, the literature, and concrete examples of the work with which they are particularly engaged. Yet it is only in rare instances that such an atmosphere, with its material appurtenances, is to be found in a printing office. Art does not flourish in hidden

abcdefghijklmnopqrstuvwxyz  
ABCDEFGHIJKLMNPOQRSTUVWXYZ  
\$1234567890

10 Point No. 204J, 8 Set

### MONOTYPE FACES

The best kind of originality is that which comes after a sound apprenticeship; that which shall prove to be the blending of a firm conception of all useful precedent and the progressive tendencies of an able mind. For, let a man be as able and original as he may, he cannot afford to discard knowledge of what has gone before or what is now going on in his own trade and profession. If the printers of today do not wish to be esteemed arrogant when they term this calling of theirs an art, they must be willing, and show that they are willing, to subject it to such laws as have made its sister arts so free. All those concerned in what are accepted as the fine arts, the learned sciences and the professions, surround themselves with the history, literature, and concrete examples of the work with which they are particularly engaged. Yet it is only in rare instances that such an atmosphere, with its material appurtenances, is to be found in a printing office. Art does not flourish in hidden places, nor under restraint, nor in ignorance of what talent and genius have accomplished and are accomplishing throughout the world. For to

abcdefghijklmnopqrstuvwxyz  
ABCDEFGHIJKLMNPOQRSTUVWXYZ  
\$1234567890

12 Point No. 204J, 10 Set

### MONOTYPE FACES

The best kind of originality is that which comes after a sound apprenticeship; that which shall prove to be the blending of a firm conception of all useful precedent and the progressive tendencies of an able mind. For, let a man be as able and original as he may, he cannot afford to discard knowledge of what has gone before or what is now going on in his own trade and profession. If the printers of today do not wish to be esteemed arrogant when they term this calling of theirs an art, they must be willing, and show that they are willing, to subject it to such laws as have made its sister arts so free. All those concerned in what are accepted as the fine arts, the learned sciences and the professions, surround themselves with the history, literature, and concrete examples of the work with which they are particularly en-

abcdefghijklmnopqrstuvwxyz  
ABCDEFGHIJKLMNPOQRSTUVWXYZ  
\$1234567890

14 Point No. 204

**DO YOU ALWAYS USE NEW TYPE,**  
Rules, leads, slugs and borders on every job, and save the expense of distribution in  
your composing room? The Monotype will supply you with all of  
this material and it will be new for every job  
**\$1234567890**

18 Point No. 204

**THIS FACE IS A GOOD FACE**  
For most any class of work, but is particularly appropriate for newspaper  
headings. You should include this handsome Gothic  
letter in your matrix equipment  
**\$1234567890**

24 Point No. 204

**MONOTYPE TYPE**  
Answers every possible requirement as to design of face,  
quality of metal, perfection of fitting and alignment  
**\$1234567890**

18 Point No. 206

### QUALITY OF OUTPUT

Is always the first consideration with Monotype printers, but quality is not all, for the Monotype is also the fastest and most versatile composing machine on all kinds of copy

\$1234567890

24 Point No. 206

### YOUR SALESMAN

The Monotype is your best salesman. It always makes a good impression by furnishing good type, and consequently better typography

\$1234567890

30 Point No. 222

### FOR A REALLY GOOD LOOKING

NEWSPAPER MONOTYPE COMPOSITION IS MOST ESSENTIAL

\$1234567890

# No. 224K. Job Arrangement C2

## Composition Matrices

5 Point No. 224K, 7½ Set

### MONOTYPE FACES

THE VERY BEST KIND OF ORIGINALITY IS THAT WHICH COMES AFTER A SOUND APPRENTICESHIP; IT IS THAT WHICH SHALL PROVE TO BE THE BLENDING OF A FIRM CONCEPTION OF ALL USEFUL PRECEDENT AND THE PROGRESSIVE TENDENCIES OF AN ABLE MIND. FOR, LET A MAN BE AS ABLE AND ORIGINAL AS HE MAY, HE CANNOT AFFORD TO DISCARD KNOWLEDGE OF WHAT HAS GONE BEFORE OR WHAT IS NOW GOING ON IN HIS OWN TRADE AND PROFESSION. IF THE PRINTERS OF TODAY DO NOT WISH TO BE ESTEEMED ARROGANT WHEN THEY TERM THIS CALLING OF THEIRS AN ART, THEY MUST BE WILLING, AND SHOW THAT THEY ARE WILLING, TO SUBJECT IT TO SUCH LAWS AS HAVE MADE ITS SISTER ARTS SO FREE. ALL THOSE CONCERNED IN WHAT ARE ACCEPTED AS THE FINE ARTS, THE LEARNED SCIENCES, AND PROFESSIONS SURROUND THEMSELVES WITH THE HISTORY, THE LITERATURE, AND CONCRETE EXAMPLES OF THE WORK WITH WHICH THEY ARE SPECIALLY ENGAGED. YET IT IS ONLY IN VERY RARE INSTANCES THAT SUCH AN ATMOSPHERE, WITH ALL ITS MATERIAL APPURTENANCES, IS FOUND IN A PRINTING OFFICE. ART DOES NOT FLOURISH IN HIDDEN PLACES, NOR UNDER RESTRAINT, NOR IN IGNORANCE OF WHAT TALENT AND GENIUS HAVE ACCOMPLISHED AND ARE ACCOMPLISHING THROUGHOUT THE WORLD. FOR TO FOLLOW PRECEDENT WISELY DOES NOT MEAN TO IMITATE SLAVISHLY ONE GREAT EXEMPLAR, BUT TO STUDY ALL MASTERS FAITHFULLY, LETTING THEIR GREAT ACHIEVEMENTS SINK SLOWLY INTO THE MIND IN ORDER THAT WE MAY PATIENTLY DERIVE FROM THE RICHNESS OF OUR ACQUIRED KNOWLEDGE AND ORGANIZED SYSTEM AN ATTITUDE OF OUR OWN. THE SPRIGHTLY MINDED YOUNG MAN, WHO WITH HIS FIRST BUSINESS BREATH PROJECTS THE NEW AND STARTLING, INEVITABLY BECOMES TIRESOME, AND IS DRIVEN TO AN EARLY DISAPPEARANCE; WHILE THE

ABCDEFGHIJKLMNPOQRSTUVWXYZ

\$1234567890

8 Point No. 224K, 10 Set

### MONOTYPE FACES

THE VERY BEST KIND OF ORIGINALITY IS THAT WHICH COMES AFTER A SOUND APPRENTICESHIP; THAT WHICH SHALL PROVE ITSELF TO BE THE BLENDING OF A FIRM CONCEPTION OF ALL USEFUL PRECEDENT AND OF THE PROGRESSIVE TENDENCIES OF AN ABLE MIND. FOR, LET A MAN BE AS ABLE AND AS ORIGINAL AS HE MAY, HE CANNOT AFFORD TO DISCARD ALL KNOWLEDGE OF WHAT HAS GONE BEFORE OR OF WHAT IS NOW GOING ON IN HIS OWN TRADE AND PROFESSION. IF THE PRINTERS OF TODAY DO NOT WISH TO BE ESTEEMED ARROGANT WHEN THEY TERM THIS CALLING OF THEIRS AN ART, THEY SHOULD BE WILLING, AND SHOW THAT THEY ARE WILLING, TO SUBJECT IT TO SUCH LAWS AS HAVE MADE ITS SISTER ARTS SO FREE. ALL THOSE CONCERNED IN WHAT ARE ACCEPTED AS THE FINE ARTS, THE LEARNED SCIENCES, AND PROFESSIONS SURROUND THEMSELVES WITH THE HISTORY, THE LITERATURE, AND CONCRETE EXAMPLES OF THE WORK WITH WHICH THEY ARE SPECIALLY ENGAGED. YET IT IS ONLY IN RARE INSTANCES THAT SUCH AN ATMOSPHERE, WITH ITS MATERIAL APPURTENANCES, IS TO BE FOUND IN A

ABCDEFGHIJKLMNPOQRSTUVWXYZ

\$1234567890

6 Point No. 224K, 8½ Set

### MONOTYPE FACES

THE VERY BEST KIND OF ORIGINALITY IS THAT WHICH COMES AFTER A SOUND APPRENTICESHIP; THAT WHICH SHALL PROVE TO BE THE BLENDING OF A FIRM CONCEPTION OF ALL USEFUL PRECEDENT AND OF THE PROGRESSIVE TENDENCIES OF AN ABLE MIND. FOR, LET A MAN BE AS ABLE AND ORIGINAL AS HE MAY, HE CANNOT AFFORD TO DISCARD KNOWLEDGE OF WHAT HAS GONE BEFORE OR WHAT IS NOW GOING ON IN HIS OWN TRADE AND PROFESSION. IF THE PRINTERS OF TODAY DO NOT WISH TO BE ESTEEMED ARROGANT WHEN THEY TERM THIS CALLING OF THEIRS AN ART, THEY MUST BE WILLING, AND SHOW THAT THEY ARE WILLING, TO SUBJECT IT TO SUCH LAWS AS HAVE MADE ITS SISTER ARTS SO FREE. ALL THOSE CONCERNED IN WHAT ARE ACCEPTED AS THE FINE ARTS, THE LEARNED SCIENCES, AND PROFESSIONS SURROUND THEMSELVES WITH THE HISTORY, THE LITERATURE, AND CONCRETE EXAMPLES OF THE WORK WITH WHICH THEY ARE PARTICULARLY ENGAGED. YET IT IS ONLY IN VERY RARE INSTANCES THAT SUCH AN ATMOSPHERE, WITH ITS MATERIAL APPURTENANCES, IS TO BE FOUND IN A PRINTING OFFICE. ART DOES NOT FLOURISH IN HIDDEN PLACES, NOR UNDER RESTRAINT, NOR IN IGNORANCE OF WHAT TALENT AND GENIUS HAVE ACCOMPLISHED AND ARE ACCOMPLISHING THROUGHOUT THE WORLD. FOR TO FOLLOW PRECEDENT

ABCDEFGHIJKLMNPOQRSTUVWXYZ

\$1234567890

10 Point No. 224K, 12 Set

### MONOTYPE FACES

THE BEST KIND OF ORIGINALITY IS THAT WHICH COMES AFTER A SOUND APPRENTICESHIP; THAT WHICH SHALL PROVE TO BE THE BLENDING OF A FIRM CONCEPTION OF ALL USEFUL PRECEDENT AND THE PROGRESSIVE TENDENCIES OF A CLEVER MIND. FOR, LET ANY MAN BE AS ABLE AND AS ORIGINAL AS HE MAY, HE CANNOT AFFORD TO DISREGARD THE KNOWLEDGE OF WHAT HAS GONE BEFORE OR WHAT IS NOW GOING ON IN HIS OWN TRADE AND PROFESSION. IF THE PRINTERS OF TODAY DO NOT WISH TO BE ESTEEMED ARROGANT WHEN THEY TERM THIS CALLING OF THEIRS AN ART, THEY MUST BE WILLING, AND SHOW THEY ARE WILLING, TO SUBJECT IT TO SUCH LAWS AS HAVE MADE ITS SISTER ARTS SO FREE. ALL THOSE WHO ARE CON-

ABCDEFGHIJKLMNPOQRSTUVWXYZ

\$1234567890

No. 227

Electro Display Matrices

14 Point No. 227

THE MONOTYPE TYPE-&RULE CASTER

MAKES THE BEST BASE MATERIAL FOR MOUNTING ALL KINDS OF CUTS, ELECTROTYPES, STEREOTYPES, OR ZINGS, AND IN JUST THE REQUIRED QUANTITY, MUCH CHEAPER THAN INFLEXIBLE STEEL BASE MATERIAL

\$1234567890

18 Point No. 227

THE FLEXIBLE MONOTYPE

FURNISHES THE FACES, AND THE COMBINATIONS OF FACES, YOUR PARTICULAR CUSTOMERS WANT AND SAVES THE DISTRIBUTION COST

\$1234567890

24 Point No. 227

EVERYTHING NEEDED

TYPE FOR THE CASES, BORDERS, ORNAMENTS, SPACES AND QUADS; RULE IN ANY LENGTH FOR EVERY JOB

\$1234567890

30 Point No. 227

THE MONOTYPE CREATED

NON-DISTRIBUTION, WHICH DOES AWAY WITH ALL THE WASTE AND IMPROVES COMPOSING ROOM PRODUCT

\$1234567890

36 Point No. 227

EVERY HOUR OF

EVERY COMPOSITOR PRODUCTIVE BY PROVIDING NEW TYPE, BORDERS, RULES, ETC.

\$1234567890

# No. 230J. Job Arrangement C4

## Composition Matrices

6 Point No. 230J, 4 1/2 Set

### MONOTYPE FACES

The best kind of originality is that which comes after a sound apprenticeship; that which shall prove itself to be the blending of a firm conception of useful precedent and the progressive tendencies of an able mind. For, let a man be as able and original as he may, he cannot afford to discard knowledge of what has gone before or what is now going on in his own trade and profession. If the printers of today do not wish to be esteemed arrogant when they term this calling of theirs an art, they must be willing, and show that they are willing, to subject it to such laws as have made its sister arts so free. All those concerned in what are accepted as the fine arts, the learned sciences and the professions, surround themselves with the history, literature, and concrete examples of the work with which they are particularly engaged. Yet it is only in rare instances that such an atmosphere, with its material appurtenances, is to be found in the printing office. Art does not flourish in hidden places, nor under restraint, nor in ignorance of what talent and genius accomplish and are now accomplishing throughout the world. For to follow precedent wisely does not mean to imitate slavishly one great exemplar, but to study all the masters faithfully, letting their greatest achievements sink slowly into the mind in order that we may patiently derive from the richness of our acquired knowledge and organized system an attitude of our very own. The sprightly minded young man, who with his first business breath projects the new and startling, inevitably becomes tiresome, and is driven to an early disappearance, while the slower, more solidly endowed student will at least spend as much of his time in avoiding mistakes as in evolving brilliant schemes wherewith to dazzle all his contemporaries. The best kind of originality is that which comes after a sound apprenticeship; that which shall prove itself to be the blending of a firm conception of useful precedent and the progressive tendencies of an able mind. For, let any man be as able and original as he may, he cannot afford to discard knowledge of what has gone before or what is now going on in his own trade and profession. If the printers of today do not wish to be esteemed arrogant when they term this calling of theirs an art, they must be willing, and show that they are willing, to subject it to such laws as have made its sister arts so free. All those concerned in what are accepted as the fine arts, the learned sciences and the professions, surround themselves with the history, literature, and concrete examples of the work with which they are particularly engaged. Yet it is only in rare instances that such an atmosphere, with its material appurtenances, is to be found in the printing office. Art does not flourish in hidden places, nor under restraint, nor in ignorance of what talent and genius accomplish and are now accomplishing throughout the world. For to follow all precedent wisely does not mean to imitate slavishly one great exemplar, but to study all the masters faithfully, letting their greatest achievements sink slowly into the mind in order that we may patiently derive from the richness of our acquired knowledge and organized system an attitude of our very own. The sprightly minded young man, who with his first business breath projects the new and startling, inevitably becomes

abcdefghijklmnopqrstuvwxy  
 ABCDEFGHIJKLMNOPQRSTUVWXYZ  
 \$1234567890

8 Point No. 230J, 5 1/2 Set

### MONOTYPE FACES

The best kind of originality is that which comes after a sound apprenticeship; that which shall prove to be the blending of a firm conception of all useful precedent and the progressive tendencies of an able mind. For, let a man be as able and original as he may, he cannot afford to discard knowledge of what has gone before or what is now going on in his own trade and profession. If the printers of today do not wish to be esteemed arrogant when they term this calling of theirs an art, they must be willing, and show that they are willing, to subject it to such laws as have made its sister arts so free. All those concerned in what are accepted as the fine arts, the learned sciences and professions, surround themselves with the history, the literature, and concrete examples of the work with which they may be particularly engaged. Yet it is only in rare instances that such an atmosphere, with its material appurtenances, is to be found in the printing office. Art does not flourish in hidden places, nor under restraint, nor in ignorance of what talent and genius have accomplished and are still accomplishing throughout the world. For to follow precedent wisely does not mean to imitate slavishly one great exemplar, but to study all the masters faithfully, letting their great achievements sink slowly into the mind, in order that we may patiently derive from the richness of our acquired knowledge and organized system an attitude of our very own. The sprightly minded young man, who with his first business breath projects the new and startling, inevitably becomes tiresome, and is driven to an early disappearance; while the slower, more solidly endowed student will at least spend as much of his time in avoiding mistakes as in evolving brilliant schemes wherewith to dazzle all his contemporaries. The best kind of originality is that which comes after a sound apprenticeship; that which shall prove itself to be the blending of a firm conception of all useful precedent and the progressive tendencies of an able mind. For, let a man be as able and original as he may, he cannot afford to discard knowledge of what has gone

abcdefghijklmnopqrstuvwxy  
 ABCDEFGHIJKLMNOPQRSTUVWXYZ  
 \$1234567890

10 Point No. 230J, 6 1/2 Set

### MONOTYPE FACES

The best kind of originality is that which comes after a sound apprenticeship; that which shall prove to be the blending of a firm conception of all useful precedent and the progressive tendencies of an able mind. For, let a man be as able and original as he may, he cannot afford to discard knowledge of what has gone before or what is now going on in his own trade and profession. If the printers of today do not wish to be esteemed arrogant when they term this calling of theirs an art, they must be willing, and show that they are willing, to subject it to such laws as have made its sister arts so free. All those concerned in what are accepted as the fine arts, the learned sciences, and professions surround themselves with the history, literature, and concrete examples of the work with which they are particularly engaged. Yet it is only in rare instances that such an atmosphere, with its material appurtenances, is to be found in a printing office. Art does not flourish in hidden places, nor under restraint, nor even in ignorance of what talent and genius have accomplished and are still accomplishing throughout the world. For to follow precedent wisely does not mean to imitate slavishly one great exemplar, but to study all the masters faithfully, letting their great achievements sink slowly into the mind in order that we may patiently derive from the richness of our acquired knowledge and organized system an attitude of our very own. The sprightly minded young man, who with his first business breath projects the new and startling, inevitably becomes tiresome, and is driven to an early disappearance; while the slower, more solidly endowed

abcdefghijklmnopqrstuvwxy  
 ABCDEFGHIJKLMNOPQRSTUVWXYZ  
 \$1234567890

12 Point No. 230J, 7 1/2 Set

### MONOTYPE FACES

The best kind of originality is that which comes after a sound apprenticeship; that which shall prove to be the blending of a firm conception of all useful precedent and the progressive tendencies of an able mind. For, let any man be as able and original as he may, he cannot afford to discard knowledge of what has gone before or what is now going on in his own trade and profession. If the printers of today do not wish to be esteemed arrogant when they term this calling of theirs an art, they must be willing, and show that they are willing, to subject it to such laws as have made its sister arts so free. All those concerned in what are accepted as the fine arts, the learned sciences and the professions, surround themselves with the history, literature, and concrete examples of the work with which they are particularly engaged. Yet it is only in rare instances that such an atmosphere, with its material appurtenances, is to be found in a printing office. Art does not flourish in hidden places, nor under restraint, nor in ignorance of what talent and genius have accomplished and are still accomplishing throughout the world. For to follow precedent

abcdefghijklmnopqrstuvwxy  
 ABCDEFGHIJKLMNOPQRSTUVWXYZ  
 \$1234567890



14 point No. 230

**FOR THE BOOK, JOB, OR NEWS PLANT**

**The Monotype has Taken the Limits out of Composition and Made it Possible to Handle any size Job in any Face of Type without Difficulty or Extra Expense**  
**\$1234567890**

18 point No. 230

**IT HAS MADE POSSIBLE THE ELIMINATION**

**Of the Disagreeable Drudgery of Distribution and Provided the Only way to keep all the Compositors on Profitable, Productive Work, all the time**  
**\$1234567890**

24 point No. 230

**WHY NOT ECONOMIZE**

**Your Compositor's Nervous Energy and Physical Strength by Giving Him Plenty of all Kinds of Material?**  
**\$1234567890**

30 point No. 230

**THE PRINTER WHO USES**

**The Monotype adds to his Sales Department the most Potent Selling Force—QUALITY**  
**\$1234567890**

36 point No. 230

**THE VERSATILE MONOTYPE**

**Supplies Printers with the Equipment to Specialize**  
**\$1234567890**

# No. 239J. Job Arrangement C4

## Composition Matrices

6 Point No. 239J, 5½ Set

### MONOTYPE FACES

The best kind of originality is that which comes after a sound apprenticeship; that which shall prove to be the blending of a firm conception of all useful precedent and the progressive tendencies of an able mind. For, let a man be as able and original as he may, he cannot afford to discard knowledge of what has gone before or what is now going on in his own trade and profession. If the printers of today do not wish to be esteemed arrogant when they term this calling of theirs an art, they must be willing, and show that they are willing, to subject it to such laws as have made its sister arts so free. All those concerned in what are accepted as the fine arts, the learned sciences, and professions surround themselves with the history, literature, and concrete examples of the work with which they are particularly engaged. Yet it is only in rare instances that such an atmosphere, with its material appurtenances, is to be found in a printing office. Art does not flourish in hidden places, nor under restraint, nor in ignorance of what talent and genius have accomplished and are now accomplishing throughout the world. For to follow precedent wisely does not mean to imitate slavishly one great exemplar, but to study all masters faithfully, letting their great achievements sink slowly into the mind in order that we may patiently derive from the richness of our acquired knowledge and organized system an attitude of our own. The sprightly minded young man, who with his first business breath projects the new and startling, inevitably becomes tiresome, and is driven to an early disappearance; while the slower, more solidly endowed student will at least spend as much of his time in avoiding mistakes as in evolving brilliant schemes wherewith to dazzle his contemporaries. The best kind of originality is that which comes after a sound apprenticeship; that which shall prove to be the blending of a firm conception of all useful precedent and the progressive tendencies of an able mind. For, let a man be as able and original as he may, he cannot afford to discard knowledge of what has gone before or what is now going on in his own trade and profession. If the printers of today do not wish to be esteemed arrogant when they term this calling of theirs an art, they must be willing, and show that they are willing, to subject it to such laws as have made its sister arts so free. All those concerned in what are accepted as the fine arts, the learned sciences, and professions surround themselves with the history, literature, and concrete examples of the work with which they are particularly engaged. Yet it is only in rare instances that such an atmosphere, with its material appurtenances, is to be found in a printing office. Art does not flourish in hidden places, nor under restraint, nor

abcdefghijklmnopqrstuvwxy  
 ABCDEFGHIJKLMNOPQRSTUVWXYZ  
 \$1234567890

10 Point No. 239J, 8 Set

### MONOTYPE FACES

The best kind of originality is that which comes after a sound apprenticeship; that which shall prove to be the blending of a firm conception of all useful precedent and the progressive tendencies of an able mind. For, let a man be as able and original as he may, he cannot afford to discard knowledge of what has gone before or what is now going on in his own trade and profession. If the printers of today do not wish to be esteemed arrogant when they term this calling of theirs an art, they must be willing, and show that they are willing, to subject it to such laws as have made its sister arts so free. All those concerned in what are accepted as the fine arts, the learned sciences, and professions surround themselves with the history, literature, and concrete examples of the work with which they are particularly engaged. Yet it is only in rare instances that such an atmosphere, with its material appurtenances, is to be found in a printing office. Art does not flourish in hidden places, nor under restraint, nor in ignorance of what talent and genius have accomplished and are now accomplishing throughout the world. For to follow precedent wisely does not mean to imitate slavishly one great exemplar, but to study all masters faithfully, letting their great achievements sink slowly into the mind in order that we may patiently derive

abcdefghijklmnopqrstuvwxy  
 ABCDEFGHIJKLMNOPQRSTUVWXYZ  
 \$1234567890

8 Point No. 239J, 6½ Set

### MONOTYPE FACES

The best kind of originality is that which comes after a sound apprenticeship; that which shall prove to be the blending of a firm conception of all useful precedent and the progressive tendencies of an able mind. For, let a man be as able and original as he may, he cannot afford to discard knowledge of what has gone before or what is now going on in his own trade and profession. If the printers of today do not wish to be esteemed arrogant when they term this calling of theirs an art, they must be willing, and show that they are willing, to subject it to such laws as have made its sister arts so free. All those concerned in what are accepted as the fine arts, the learned sciences, and professions surround themselves with the history, literature, and concrete examples of the work with which they are particularly engaged. Yet it is only in rare instances that such an atmosphere, with its material appurtenances, is to be found in a printing office. Art does not flourish in hidden places, nor under restraint, nor in ignorance of what talent and genius have accomplished and are accomplishing throughout the world. For to follow precedent wisely does not mean to imitate slavishly one great exemplar, but to study all masters faithfully, letting their great achievements sink slowly into the mind in order that we may patiently derive from the richness of our acquired knowledge and organized system an attitude of our own. The sprightly minded young man, who with his first business breath projects the new and startling, inevitably becomes tiresome, and is driven to an early disappearance; while the slower, more solidly endowed student will at least spend as much of his time in avoiding mistakes as in evolving brilliant schemes wherewith to dazzle his contemporaries. The best kind of orig-

abcdefghijklmnopqrstuvwxy  
 ABCDEFGHIJKLMNOPQRSTUVWXYZ  
 \$1234567890

12 Point No. 239J, 9½ Set

### MONOTYPE FACES

The best kind of originality is that which comes after a sound apprenticeship; that which shall prove to be the blending of a firm conception of all useful precedent and the progressive tendencies of an able mind. For, let a man be as able and original as he may, he cannot afford to discard knowledge of what has gone before or what is now going on in his own trade and profession. If the printers of today do not wish to be esteemed arrogant when they term this calling of theirs an art, they must be willing, and show that they are willing, to subject it to such laws as have made its sister arts so free. All those concerned in what are accepted as the fine arts, the learned sciences, and professions surround themselves with the history, literature, and concrete examples of the work with which they are particularly engaged. Yet it is only in rare instances that such an atmosphere, with its material appurtenances, is to be found in a

abcdefghijklmnopqrstuvwxy  
 ABCDEFGHIJKLMNOPQRSTUVWXYZ  
 \$1234567890

14 point No. 239

**THE MONOTYPE: TWO MACHINES IN ONE**

**It Casts Type for the Cases; It Sets, Justifies, and Delivers on the Galley, Composition that Surpasses the Most Careful Hand Justification**

**\$1234567890**

18 point No. 239

**MONOTYPE COMPOSITION UNEQUALED**

**Either on Straight Matter or on Intricate Tabular Work, the Monotype Distinctly shows Its Superiority**

**\$1234567890**

24 point No. 239

**DISPLAY TYPE UNLIMITED**

**Where there is a Monotype Equipment Time Lost Picking for Sorts, etc., is Dispensed With**

**\$1234567890**

30 point No. 239

**LEADS AND SLUGS**

**Can be Cast to any length at a Speed that makes Distribution Unprofitable**

**\$1234567890**

36 point No. 239

**RULES ALWAYS NEW**

**Full length Rules on Every Job, no piecing**

**\$1234567890**

# No. 240J. Job Arrangement C4

## Composition Matrices

6 Point No. 240J, 7 Set

### MONOTYPE FACES

The best kind of originality is that which comes after a sound apprenticeship; that which shall prove to be the blending of a firm conception of all useful precedent and the progressive tendencies of an able mind. For, let a man be as able and original as he may, he cannot afford to discard knowledge of what has gone before or what is now going on in his own trade and profession. If the printers of today do not wish to be esteemed arrogant when they term this calling of theirs an art, they must be willing, and show that they are willing, to subject it to such laws as have made its sister arts so free. All those concerned in what are accepted as the fine arts, the learned sciences, and professions surround themselves with the history, literature, and concrete examples of the work with which they are particularly engaged. Yet it is only in rare instances that such an atmosphere, with its material appurtenances, is to be found in a printing office. Art does not flourish in hidden places, nor under restraint, nor in ignorance of what talent and genius have accomplished and are now accomplishing throughout the world. For to follow precedent wisely does not mean to imitate slavishly one great exemplar, but to study all masters faithfully, letting their great achievements sink slowly into the mind in order that we may patiently derive from the richness of our acquired knowledge and organized system an attitude of our own. The sprightly minded young man, who with his first business breath projects the new and startling, inevitably becomes tiresome, and is driven to an early disappearance; while the slower, more solidly endowed student will at least spend as much of his time in avoiding mistakes as in evolving brilliant schemes wherewith to dazzle his contemporaries. The very best kind of originality is that which comes after a sound apprenticeship; that which shall prove to be the blending of a firm conception of all useful precedent and the progressive tendencies of an able mind. For, let a man be as able and original as he may, he cannot afford to discard knowledge of what has gone before or what is now going on in his own trade and profession.

abcdefghijklmnopqrstuvwxyz  
 ABCDEFGHIJKLMNOPQRSTUVWXYZ  
 \$1234567890

8 Point No. 240J, 8 1/2 Set

### MONOTYPE FACES

The best kind of originality is that which comes after a sound apprenticeship; that which shall prove to be the blending of a firm conception of useful precedent and the progressive tendencies of an able mind. For, let a man be as able and original as he may, he cannot afford to discard knowledge of what has gone before or what is now going on in his own trade and profession. If the printers of today do not wish to be esteemed arrogant when they term this calling of theirs an art, they must be willing, and show that they are willing, to subject it to such laws as have made its sister arts so free. All those concerned in what are accepted as the fine arts, the learned sciences and the professions, surround themselves with the history, literature, and concrete examples of the work with which they are particularly engaged. Yet it is only in rare instances that such an atmosphere, with its material appurtenances, is to be found in the printing office. Art does not flourish in hidden places, nor under restraint, nor in ignorance of what talent and genius have accomplished and are now accomplishing throughout the world. For to follow all precedent wisely does not mean to imitate slavishly one great exemplar, but to study all the masters faithfully, letting their great achievements sink slowly into the mind in order that we may patiently derive from the richness of our

abcdefghijklmnopqrstuvwxyz  
 ABCDEFGHIJKLMNOPQRSTUVWXYZ  
 \$1234567890

10 Point No. 240J, 10 Set

### MONOTYPE FACES

The best kind of originality is that which comes after a sound apprenticeship; that which shall prove to be the blending of a firm conception of all useful precedent and the progressive tendencies of an able mind. For, let a man be as able and original as he may, he cannot afford to discard knowledge of what has gone before or what is now going on in his own trade and profession. If the printers of today do not wish to be esteemed arrogant when they term this calling of theirs an art, they must be willing, and show that they are willing, to subject it to such laws as have made its sister arts so free. All those concerned in what are accepted as the fine arts, the learned sciences and professions, surround themselves with the history, the literature, and concrete examples of the work with which they may be particularly engaged. Yet it is only in rare instances that such an atmosphere, with its material appurtenances, is to be found in the printing office. Art does not flourish in hidden places, nor under restraint, nor in ignorance of what talent and genius have ac-

abcdefghijklmnopqrstuvwxyz  
 ABCDEFGHIJKLMNOPQRSTUVWXYZ  
 \$1234567890

12 Point No. 240J, 12 Set

### MONOTYPE FACES

The best kind of originality is that which comes after a sound apprenticeship; that which shall prove to be the blending of a firm conception of all useful precedent and the progressive tendencies of an able mind. For, let a man be as able and original as he may, he cannot afford to discard knowledge of what has gone before or what is now going on in his own trade and profession. If the printers of today do not wish to be esteemed arrogant when they term this calling of theirs an art, they must be willing, and show that they are willing, to subject it to such laws as have made its sister arts so free. All those concerned in what are accepted as the fine arts, the learned sciences, and professions surround themselves with the

abcdefghijklmnopqrstuvwxyz  
 ABCDEFGHIJKLMNOPQRSTUVWXYZ  
 \$1234567890

No. 240

Electro Display Matrices

14 point No. 240

**THE ONLY MACHINE**  
That will Prove that It is Equally Efficient on Every Possible Kind of  
Modern Composing Room Work  
**\$1234567890**

18 point No. 240

**THE MONOTYPE IS BUILT**  
Upon the Principle that the Printer is the Best Judge of  
his own Requirements  
**\$1234567890**

24 point No. 240

**MONOTYPE MATRICES**  
Are Quite as Perfect as the Matrices used by  
The Best Type Founders  
**\$1234567890**

30 point No. 240

**THE MONOTYPE**  
Takes all the Limitations out of Your  
Machine Composition  
**\$1234567890**

36 point No. 240

**BRAND NEW TYPE**  
for Every Job; No Distribution  
**\$1234567890**

# No. 249J. Job Arrangement C2

## Composition Matrices

6 Point No. 249J, 7 Set

### MONOTYPE FACES

The best kind of originality is that which comes after a sound apprenticeship; that which shall prove to be the blending of a firm conception of all useful precedent and the progressive tendencies of an able mind. For, let a man be as able and original as he may be, he cannot afford to discard knowledge of what has gone before or what is now going on in his own trade and profession. If the printers of today do not wish to be esteemed arrogant when they term this calling of theirs an art they must be willing, and show that they are willing, to subject it to such laws as have made its sister arts so free. All those concerned in what are accepted as the fine arts, the learned sciences, and professions surround themselves with the history, the literature, and concrete examples of the work with which they are particularly engaged. Yet it is only in very rare instances that such an atmosphere, with its material appurtenances, is to be found in a printing office. Art does not flourish in hidden places, nor under restraint, nor in ignorance of what talent and genius have accomplished and are accomplishing throughout the world. For to follow precedent wisely does not

abcdefghijklmnopqrstuvwxy  
ABCDEFGHIJKLMNOPQRSTUVWXYZ  
\$1234567890

7 Point No. 249J, 8 Set

### MONOTYPE FACES

The best kind of originality is that which comes after a sound apprenticeship; that which shall prove to be the blending of a firm conception of all useful precedent and the progressive tendencies of an able mind. For, let a man be as able and original as he may, he cannot afford to discard knowledge of what has gone before or what is now going on in his own trade and profession. If the printers of today do not wish to be esteemed too arrogant when they term this calling of theirs an art, they must be willing, and show that they are willing, to subject it to such laws as have made its sister arts so free. All those concerned in what are accepted as the fine arts, the learned sciences, and the professions surround themselves with the history, the literature, and the concrete examples of the work with which they are particularly engaged. Yet it is only in

abcdefghijklmnopqrstuvwxy  
ABCDEFGHIJKLMNOPQRSTUVWXYZ  
\$1234567890

8 Point No. 249J, 8½ Set

### MONOTYPE FACES

The best kind of originality is that which comes after a sound apprenticeship; that which shall prove to be the blending of a firm conception of all useful precedent and the progressive tendencies of an able mind. For, let a man be as able and original as he may be, he cannot afford to discard knowledge of what has gone before or what is now going on in his own trade or his profession. If the printers of today do not wish to be esteemed arrogant when they term this calling of theirs an art, they must be willing, and show that they are willing, to subject it to such laws as have made its sister arts so free. All those concerned in what are accepted as the fine

abcdefghijklmnopqrstuvwxy  
ABCDEFGHIJKLMNOPQRSTUVWXYZ  
\$1234567890

10 Point No. 249J, 10 Set

### MONOTYPE FACES

The best kind of originality is that which comes after a sound apprenticeship; that which shall prove to be the blending of a firm conception of all useful precedent and the progressive tendencies of an able mind. For, let any man be as able and original as he may, he cannot afford entirely to discard knowledge of what has gone before or what is now going on in his own trade and profession. If the printers of today do not wish to be esteemed too arrogant when they term this calling of theirs an art, they must be willing, and show that they are willing, to subject it to such laws as have made its sister arts so free. All those concerned in what are accepted as the fine arts, the learned sciences, and the professions surround themselves with the history, literature, and concrete examples of the work with which they are particu-

abcdefghijklmnopqrstuvwxy  
ABCDEFGHIJKLMNOPQRSTUVWXYZ  
\$1234567890

12 Point No. 249J, 12 Set

### MONOTYPE FACES

The best kind of originality is that which comes after a sound apprenticeship; that which shall prove to be the blending of a firm conception of all useful precedent and the progressive tendencies of an able mind. For, let a man be as able and original as he may, he cannot afford to discard a knowledge of what has gone before or what is now going on in his own trade and profession. If the printers of today do not wish to be esteemed arrogant when they term this calling of theirs an art, they must be willing, and show that they are willing, to subject it to such laws as have made its sister arts so free.

abcdefghijklmnopqrstuvwxy  
ABCDEFGHIJKLMNOPQRSTUVWXYZ  
\$1234567890

14 Point No. 276

**IF YOU HAVE NOT HEARD, LISTEN!**  
**Monotypes are making money for their owners all over the United States**  
**and in nearly every civilized country in the world**  
**\$1234567890**

18 Point No. 276

**IF YOU ARE FROM MISSOURI**  
**Write to Philadelphia and we will tell you of a near-by**  
**plant where you can see for yourself**  
**\$1234567890**

24 Point No. 276

**ABCDEFGHIJKLMNOPQRSTUVWXYZ&.,:;- ' ! ?**  
**abcdefghijklmnopqrstuvwxyz**  
**\$1234567890**

A Minimum Job Font contains 72 characters, as shown above

30 Point No. 276

**MONOTYPE PRODUCT**  
**Is Superior in Quality to any Other**  
**Process of Composition**  
**\$1234567890**

36 Point No. 276

**COMPLETE FLEXIBILITY**  
**Makes Combining Faces Easy**  
**\$1234567890**

No. 254K. Job Arrangement C2  
Composition Matrices

6 Point No. 254K, 8 Set

(This font contains caps and small caps)

**MONOTYPE FACES: 5 POINT CAPS**

THE BEST KIND OF ORIGINALITY IS THAT WHICH COMES AFTER A SOUND APPRENTICESHIP; THAT WHICH SHALL PROVE TO BE THE BLENDING OF A FIRM CONCEPTION OF ALL USEFUL PRECEDENT AND THE PROGRESSIVE TENDENCIES OF AN ABLE MIND. FOR, LET A MAN BE AS ABLE AND ORIGINAL AS HE MAY, HE CANNOT AFFORD TO DISCARD A KNOWLEDGE OF WHAT HAS GONE BEFORE OR

ABCDEFGHIJKLMNOPQRSTUVWXYZ

\$1234567890

**MONOTYPE FACES. 6 POINT SMALL CAPS**

WHAT IS NOW GOING ON IN HIS OWN TRADE AND PROFESSION. IF THE PRINTERS OF TODAY DO NOT WISH TO BE ESTEEMED ARROGANT WHEN THEY TERM THIS CALLING OF THEIRS AN ART, THEY MUST BE WILLING, AND SHOW THAT THEY ARE WILLING, TO SUBJECT IT TO SUCH LAWS AS HAVE MADE ITS SISTER ARTS SO FREE. ALL THOSE CONCERNED IN WHAT ARE ACCEPTED AS THE FINE ARTS, THE LEARNED SCIENCES, AND THE PROFESSIONS SURROUND THEMSELVES WITH THE HISTORY, LITERATURE, AND

ABCDEFGHIJKLMNOPQRSTUVWXYZ

\$1234567890

**MONOTYPE FACES. 6 POINT CAPS AND SMALL CAPS**

CONCRETE EXAMPLES OF THE WORK WITH WHICH THEY ARE PARTICULARLY ENGAGED. YET IT IS ONLY IN RARE INSTANCES THAT SUCH AN ATMOSPHERE, WITH ITS MATERIAL APPURTENANCES, IS TO BE FOUND IN A PRINTING OFFICE. ART DOES NOT FLOURISH IN HIDDEN PLACES NOR UNDER RESTRAINT, NOR IN IGNORANCE OF WHAT TALENT AND GENIUS HAVE ACCOMPLISHED AND ARE ACCOMPLISHING THROUGHOUT THE WORLD. FOR TO FOLLOW PRECEDENT WISELY DOES NOT

8 Point No. 254K, 10 Set

(This font contains caps and small caps)

**MONOTYPE FACES: 8 POINT CAPS**

THE BEST KIND OF ORIGINALITY IS THAT WHICH COMES AFTER A SOUND APPRENTICESHIP; THAT WHICH SHALL PROVE TO BE THE BLENDING OF A FIRM CONCEPTION OF ALL USEFUL PRECEDENT AND THE PROGRESSIVE TENDEN-

ABCDEFGHIJKLMNOPQRSTUVWXYZ

\$1234567890

**MONOTYPE FACES. 8 POINT SMALL CAPS**

CIES OF AN ABLE MIND. FOR, LET A MAN BE AS ABLE AND ORIGINAL AS HE MAY, HE CANNOT AFFORD TO DISCARD KNOWLEDGE OF WHAT HAS GONE BEFORE OR WHAT IS NOW GOING ON IN HIS OWN TRADE AND PROFESSION. IF THE PRINTERS OF TODAY DO NOT WISH TO BE ESTEEMED ARROGANT

ABCDEFGHIJKLMNOPQRSTUVWXYZ

\$1234567890

**MONOTYPE FACES. 8 POINT CAPS AND SMALL CAPS**

WHEN THEY TERM THIS CALLING OF THEIRS AN ART, THEY MUST BE WILLING, AND SHOW THAT THEY ARE WILLING, TO SUBJECT IT TO SUCH LAWS AS HAVE MADE ITS SISTER ARTS SO FREE. ALL THOSE CONCERNED IN WHAT ARE ACCEPTED AS THE FINE ARTS, THE LEARNED SCIENCES, AND THE

7 Point No. 254K, 9 Set

**MONOTYPE FACES**

THE BEST KIND OF ORIGINALITY IS THAT WHICH COMES AFTER A SOUND APPRENTICESHIP; THAT WHICH SHALL PROVE TO BE THE BLENDING OF A FIRM CONCEPTION OF ALL USEFUL PRECEDENT AND OF THE PROGRESSIVE TENDENCIES OF AN ABLE MIND. FOR, LET A MAN BE AS ABLE AND ORIGINAL AS HE MAY, HE CANNOT AFFORD TO DISCARD KNOWLEDGE OF WHAT HAS GONE BEFORE OR WHAT IS NOW GOING ON IN HIS OWN TRADE AND PROFESSION. IF THE PRINTERS OF TODAY DO NOT WISH TO BE ESTEEMED ARROGANT WHEN THEY TERM THIS CALLING OF THEIRS AN ART, THEY MUST BE WILLING, AND SHOW THAT THEY ARE WILLING, TO SUBJECT IT TO SUCH LAWS AS HAVE MADE ITS SISTER ARTS SO FREE. ALL THOSE CONCERNED IN WHAT ARE ACCEPTED AS THE FINE ARTS, THE LEARNED SCIENCES, AND THE PROFESSIONS SURROUND THEMSELVES WITH THE HISTORY, LITERATURE, AND THE CONCRETE EXAMPLES OF THE WORK WITH WHICH THEY ARE PARTICULARLY ENGAGED. YET IT IS ONLY IN VERY RARE INSTANCES THAT SUCH AN ATMOSPHERE, WITH ITS MATERIAL APPURTENANCES, IS TO BE FOUND IN A PRINTING OFFICE. ART DOES NOT

ABCDEFGHIJKLMNOPQRSTUVWXYZ

\$1234567890

10 Point No. 254K, 12 1/2 Set

**MONOTYPE FACES**

THE BEST KIND OF ORIGINALITY IS THAT WHICH COMES AFTER A SOUND APPRENTICESHIP; THAT WHICH SHALL PROVE TO BE THE BLENDING OF A FIRM CONCEPTION OF ALL USEFUL PRECEDENT AND OF THE PROGRESSIVE TENDENCIES OF AN ABLE MIND. FOR, LET A MAN BE AS ABLE AND ORIGINAL AS HE MAY, HE CANNOT AFFORD TO DISCARD KNOWLEDGE OF WHAT HAS GONE BEFORE OR WHAT IS NOW GOING ON IN HIS OWN TRADE AND HIS PROFESSION. IF THE PRINTERS OF TODAY DO NOT WISH TO BE ESTEEMED ARROGANT WHEN THEY TERM THIS CALLING OF THEIRS

ABCDEFGHIJKLMNOPQRSTUVWXYZ

\$1234567890

Note that the figures shown with ~~these~~ ~~series~~ ~~cannot~~ be composed with these fonts using standard ~~C2~~ keyboards. The F246 figures shown with the capitals are 12 units and the F254K figures shown with the small capitals are 9 units



14B Point No. 2541

**THE MONOTYPE SYSTEM SUPPLIES  
PRINTERS WITH THE MEANS FOR PRODUCING WORK OF  
THE HIGHEST QUALITY**

**\$1234567890**

14 Point No. 2541

**THE CORNER STONE  
OF THE MONOTYPE SYSTEM OF EFFICIENCY  
IS CONTINUOUS PRODUCTION**

**\$1234567890**

18 Point No. 2541

**A NEW PROCESS OF  
COMPOSITION IS MADE POSSIBLE  
BY THE DUPLEX KEYBOARD**

**\$1234567890**

24 Point No. 2541

**THE MONOTYPE IS  
THE SIMPLEST AND FASTEST  
COMPOSING MACHINE**

**\$1234567890**

30 Point No. 2541

**MONOTYPE  
MATRICES HELP YOU  
SELL PRINTING**

**\$1234567890**

No. 366J. Job Arrangement C2

Composition Matrices

10 Point No. 366J, 10½ Set

**MONOTYPE FACES**

THE BEST KIND OF ORIGINALITY IS THAT WHICH COMES AFTER A SOUND APPRENTICESHIP; THAT WHICH SHALL PROVE TO BE THE BLENDING OF A FIRM CONCEPTION OF ALL USEFUL PRECEDENT AND THE PROGRESSIVE TENDENCIES OF AN ABLE MIND. FOR, LET A MAN BE AS ABLE AND ORIGINAL AS HE MAY, HE CANNOT AFFORD TO DISCARD KNOWLEDGE OF WHAT HAS GONE BEFORE OR WHAT IS NOW GOING ON IN HIS OWN TRADE AND PROFESSION. IF THE PRINTERS OF TODAY DO NOT WISH TO BE ESTEEMED ARROGANT WHEN THEY TERM THIS CALLING OF THEIRS AN ART, THEY MUST BE WILLING, AND SHOW THAT THEY ARE WILLING, TO SUBJECT IT TO SUCH LAWS AS HAVE MADE ITS SISTER ARTS SO FREE. THOSE CONCERNED IN WHAT ARE ACCEPTED AS THE FINE ARTS, THE LEARNED SCIENCES AND PROFESSIONS, SURROUND THEMSELVES WITH THE HISTORY, LITERATURE, AND CONCRETE EXAMPLES OF THE WORK WITH WHICH THEY ARE PARTICULARLY ENGAGED. YET IT IS ONLY IN RARE INSTANCES THAT SUCH AN ATMOSPHERE, WITH ITS MATERIAL APPURTENANCES, IS TO BE FOUND IN A PRINTING OFFICE. ART DOES NOT FLOURISH IN HIDDEN PLACES, NOR UNDER RESTRAINT, NOR IN IGNORANCE OF WHAT TALENT AND GENIUS ACCOMPLISHED AND ARE ACCOMPLISHING THROUGHOUT THE WORLD. FOR TO FOLLOW ALL PRECEDENT WISELY DOES NOT MEAN TO IMITATE SLAVISHLY ONE GREAT EXEMPLAR, BUT TO STUDY ALL THE MASTERS FAITHFULLY, LETTING THEIR GREAT ACHIEVEMENTS SINK SLOWLY INTO THE MIND IN ORDER THAT WE MAY PATIENTLY DERIVE FROM THE RICHNESS OF OUR ACQUIRED KNOWLEDGE AND ORGANIZED SYS-

ABCDEFGHIJKLMN**OP**QRSTU**VW**XYZ

\$1234567890

12 Point No. 366J 12½ Set

**MONOTYPE FACES**

THE BEST KIND OF ORIGINALITY IS THAT WHICH COMES AFTER A SOUND APPRENTICESHIP; THAT WHICH SHALL PROVE TO BE THE BLENDING OF A FIRM CONCEPTION OF ALL USEFUL PRECEDENT AND THE PROGRESSIVE TENDENCIES OF AN ABLE MIND. FOR, LET ANY MAN BE AS ABLE AND ORIGINAL AS HE MAY, HE CANNOT AFFORD TO DISCARD KNOWLEDGE OF WHAT HAS GONE BEFORE OR WHAT IS NOW GOING ON IN HIS OWN TRADE AND PROFESSION. IF THE PRINTERS OF TODAY DO NOT WISH TO BE ESTEEMED ARROGANT WHEN THEY TERM THIS CALLING OF THEIRS AN ART, THEY MUST BE WILLING AND SHOW THAT THEY ARE WILLING TO SUBJECT IT TO SUCH LAWS AS HAVE MADE ITS SISTER ARTS SO FREE. ALL THOSE WHO ARE CONCERNED IN WHAT ARE ACCEPTED AS THE FINE ARTS, THE LEARNED SCIENCES AND PROFESSIONS, SURROUND THEMSELVES WITH THE HISTORY, LITERATURE, AND CONCRETE EXAMPLES OF THE WORK WITH WHICH THEY ARE PARTICULARLY ENGAGED. YET IT IS ONLY IN RARE INSTANCES THAT SUCH AN ATMOSPHERE, WITH ITS MATERIAL APPURTENANCES, IS TO BE FOUND IN A PRINTING

ABCDEFGHIJKLMN**OP**QRSTU**VW**XYZ

\$1234567890

14 Point No. 366

**YOU CAN SAVE  
IN PRESS MAKE-READY BY PROVIDING BRAND-  
NEW TYPE FOR EVERY JOB  
\$1234567890**

18 Point No. 366

**OUR TYPE-&-RULE  
CASTERS KEEP A CONTINUOUS SUPPLY  
OF TYPE, RULES, LEADS, SLUGS  
\$1234567890**

24 Point No. 366

**THE FLEXIBLE MONOTYPE  
TOOK THE LIMITATIONS OUT OF  
MACHINE COMPOSITION  
\$1234567890**

30 Point No. 366

**NEW TYPE  
GIVES CLEAN AND SHARP  
IMPRESSIONS  
\$1234567890**

The fonts shown on this page contain matrices symbolized No. 66 and No. 366, but the entire fonts are called No. 366.

# PLATE - GOTHIC No. 340J SERIES

## COMPOSITION MATRICES

**T**HE Plate-Gothics are so arranged that all four sizes of six-point are carried in one Matrix Case and, similarly, all four sizes of twelve-point are carried in one Matrix Case. Thus, four sizes may be composed at one operation on the Style D Keyboard, or eight sizes on the Duplex Keyboard, and cast in justified lines on the Casting Machine. At the Keyboard the right and left Keybars and Keybanks P-G and the Stopbars S108 are required, and at the Casting Machine the Normal Wedge S108 is required. A five-unit high space is required before the M and W of both six- and twelve-point No. 1 size of the 340J series.

Both six-point and twelve-point fonts will line when cast in composition on the same Mold, but to justify the six-point with the twelve-point, when setting by hand, the following plan has been adopted: The twelve-point remains on its standard line, .1250, but the six-point is cast to .0697 line. The six-point is then justified to the twelve-point by placing four points above and two points below the six-point type. Electro-Display Matrices of the No. 187 series, shown on page four, are the same type design and are an extension of this 340J series and justify with twelve-point by point justification. To justify together the twelve-, fourteen-, eighteen-, and twenty-four-point sizes, place all the spacing at the top. This makes all sizes line. The comma, semi-colon, and tail of the Cap Q of the eighteen- and twenty-four-point sizes will overhang the body slightly, and there will be a slight overhang at the top of the 18H4 and 24H4 sizes.

This plan for point line justifying all sizes of the Plate-Gothic for hand composition applies to all series of Plate-Gothics now ready and those that may be added in the future. The line standards for casting type for hand composition for Plate-Gothics according to the above plan will be as follows:

|              |                   |                |       |
|--------------|-------------------|----------------|-------|
| Six-point    | .0697             | Fourteen-point | .1527 |
| Twelve-point | .1250 (Standard)  | Eighteen-point | .2080 |
|              | Twenty-four-point | .2910          |       |

The Draw Rod should be readjusted to suit the movement of the Centering Pin when running on special line adjustment in order to produce the point-line justification.

THE FRENCH SHOP  
SILKS  
CHESTNUT AND FIFTH AVENUE  
PITTSBURGH

DEAR MADAM:  
THIS WILL INFORM  
BEAUTIFUL COLORS AND FINE

SKETCH CLUB  
EXHIBITION OF WATER COLORS

AT THE  
CLUB HOUSE  
FEBRUARY 4, 5, 6 AND 7, 1920  
EIGHT THIRTY IN THE EVENING

ADMIT ONE

10 BOULEVARD

JACQUIN GARDENS  
CORPORATION  
GROWERS AND DISTRIBUTORS OF  
ORANGES, LEMONS AND CITRUS FRUIT  
JACQUIN, CALIFORNIA

SAMUEL A. HARGRAVES  
PHILADELPHIA OFFICE MGR.

123 NORTH MARKET STREET  
PHILADELPHIA, PA.

STY SHADES OF  
VARIETY ONLY  
OUR CALL YOUR

FEBRUARY, 1920

# No. 340J. Arrangement P-G—Composition Matrices

Specimens of the four sizes contained in each matrix case, each size shown separately

12 Point No. 340J, 11 Set

No. 1

THE BEST KIND OF ORIGINALITY IS THAT WHICH COMES AFTER A SOUND APPRENTICESHIP; THAT WHICH SHALL PROVE TO BE THE BLENDING OF A FIRM CONCEPTION OF ALL USEFUL PRECEDENT AND THE PROGRESSIVE TENDENCIES OF AN ABLE MIND. FOR,

ABCDEFGHIJKLMN**OP**QRSTUVWXYZ

\$1234567890

No. 2

THE BEST KIND OF ORIGINALITY IS THAT WHICH COMES AFTER A SOUND APPRENTICESHIP; THAT WHICH SHALL PROVE TO BE THE BLENDING OF A FIRM CONCEPTION OF ALL USEFUL PRECEDENT AND THE PROGRESSIVE TENDENCIES OF AN ABLE MIND. FOR, LET A MAN BE AS ABLE AND ORIGINAL

ABCDEFGHIJKLMN**OP**QRSTUVWXYZ

\$1234567890

No. 3

THE BEST KIND OF ORIGINALITY IS THAT WHICH COMES AFTER A SOUND APPRENTICESHIP; THAT WHICH SHALL PROVE TO BE THE BLENDING OF A FIRM CONCEPTION OF ALL USEFUL PRECEDENT AND THE PROGRESSIVE TENDENCIES OF AN ABLE MIND. FOR, LET A MAN BE AS ABLE AND ORIGINAL AS HE MAY, HE CANNOT AFFORD TO DISCARD

ABCDEFGHIJKLMN**OP**QRSTUVWXYZ

\$1234567890

No. 4

THE BEST KIND OF ORIGINALITY IS THAT WHICH COMES AFTER A SOUND APPRENTICESHIP; THAT WHICH SHALL PROVE TO BE THE BLENDING OF A FIRM CONCEPTION OF ALL USEFUL PRECEDENT AND THE PROGRESSIVE TENDENCIES OF AN ABLE MIND. FOR, LET A MAN BE AS ABLE AND ORIGINAL AS HE MAY, HE CANNOT AFFORD TO DISCARD A KNOWLEDGE OF WHAT HAS GONE BEFORE OR WHAT IS

ABCDEFGHIJKLMN**OP**QRSTUVWXYZ

\$1234567890

6 Point No. 340J, 7 Set

No. 1

THE BEST KIND OF ORIGINALITY IS THAT WHICH COMES AFTER A SOUND APPRENTICESHIP; THAT WHICH SHALL PROVE TO BE THE BLENDING OF A FIRM CONCEPTION OF ALL USEFUL PRECEDENT AND THE PROGRESSIVE TENDENCIES OF AN ABLE MIND. FOR, LET A MAN BE AS ABLE AND ORIGINAL AS HE MAY, HE CANNOT AFFORD TO DISCARD KNOWLEDGE OF WHAT HAS GONE BEFORE OR WHAT IS NOW GOING ON IN HIS OWN TRADE AND PROFESSION. IF THE PRINTERS OF TODAY DO NOT WISH TO BE ESTEEMED ARROGANT WHEN THEY TERM THIS CALLING OF THEIRS AN ART, THEY MUST

ABCDEFGHIJKLMN**OP**QRSTUVWXYZ

\$1234567890

No. 2

THE BEST KIND OF ORIGINALITY IS THAT WHICH COMES AFTER A SOUND APPRENTICESHIP; THAT WHICH SHALL PROVE TO BE THE BLENDING OF A FIRM CONCEPTION OF ALL USEFUL PRECEDENT AND THE PROGRESSIVE TENDENCIES OF AN ABLE MIND. FOR, LET A MAN BE AS ABLE AND ORIGINAL AS HE MAY, HE CANNOT AFFORD TO DISCARD KNOWLEDGE OF WHAT HAS GONE BEFORE OR WHAT IS NOW GOING ON IN HIS OWN TRADE AND HIS PROFESSION. IF THE PRINTERS OF TODAY DO NOT WISH TO BE ESTEEMED ARROGANT WHEN THEY TERM THIS CALLING OF THEIRS AN ART, THEY MUST BE WILLING, AND SHOW THAT THEY ARE WILLING, TO SUBJECT IT TO SUCH LAWS

ABCDEFGHIJKLMN**OP**QRSTUVWXYZ

\$1234567890

No. 3

THE BEST KIND OF ORIGINALITY IS THAT WHICH COMES AFTER A SOUND APPRENTICESHIP; THAT WHICH SHALL PROVE TO BE THE BLENDING OF A FIRM CONCEPTION OF ALL USEFUL PRECEDENT AND THE PROGRESSIVE TENDENCIES OF AN ABLE MIND. FOR, LET A MAN BE AS ABLE AND ORIGINAL AS HE MAY, HE CANNOT AFFORD TO DISCARD A KNOWLEDGE OF WHAT HAS GONE BEFORE OR WHAT IS NOW GOING ON IN HIS OWN TRADE AND PROFESSION. IF THE PRINTERS OF TODAY DO NOT WISH TO BE ESTEEMED ARROGANT WHEN THEY TERM THIS CALLING OF THEIRS AN ART, THEY MUST BE WILLING, AND SHOW THAT THEY ARE WILLING, TO SUBJECT IT TO SUCH LAWS AS HAVE MADE ITS SISTER ARTS SO FREE. ALL THOSE CONCERNED IN WHAT ARE ACCEPTED AS THE FINE ARTS, THE LEARNED

ABCDEFGHIJKLMN**OP**QRSTUVWXYZ

\$1234567890

No. 4

THE BEST KIND OF ORIGINALITY IS THAT WHICH COMES AFTER A SOUND APPRENTICESHIP; THAT WHICH SHALL PROVE TO BE THE BLENDING OF A FIRM CONCEPTION OF ALL USEFUL PRECEDENT AND THE PROGRESSIVE TENDENCIES OF AN ABLE MIND. FOR, LET A MAN BE AS ABLE AND ORIGINAL AS HE MAY, HE CANNOT AFFORD TO DISCARD A KNOWLEDGE OF WHAT HAS GONE BEFORE OR WHAT IS NOW GOING ON IN HIS OWN TRADE AND PROFESSION. IF THE PRINTERS OF TODAY DO NOT WISH TO BE ESTEEMED ARROGANT WHEN THEY TERM THIS CALLING OF THEIRS AN ART, THEY MUST BE WILLING, AND SHOW THAT THEY ARE WILLING, TO SUBJECT IT TO SUCH LAWS AS HAVE MADE ITS SISTER ARTS SO FREE. ALL THOSE CONCERNED IN WHAT ARE ACCEPTED AS THE FINE ARTS, THE LEARNED SCIENCES, AND PROFESSIONS SURROUND THEMSELVES WITH

ABCDEFGHIJKLMN**OP**QRSTUVWXYZ

\$1234567890

ELECTRO-DISPLAY MATRICES No. 187, shown on page four, are the same type design and are an extension of the 340J Series shown on this page

# No. 340J. Arrangement P-G—Composition Matrices

Specimens of all the possible cap and small cap combinations that can be made with the four sizes in each matrix case

6 Point No. 340J, 7 Set

Nos. 1 and 2

THE BEST KIND OF ORIGINALITY IS THAT WHICH COMES AFTER A SOUND APPRENTICESHIP; THAT WHICH SHALL PROVE TO BE THE BLENDING OF A FIRM CONCEPTION OF ALL USEFUL PRECEDENT AND THE PROGRESSIVE TENDENCIES OF AN ABLE MIND. FOR, LET A MAN BE AS ABLE AND ORIGINAL AS HE MAY, HE CANNOT AFFORD TO DISCARD A KNOWLEDGE OF WHAT HAS GONE BEFORE OR WHAT IS NOW GOING ON IN HIS

Nos. 1 and 3

THE BEST KIND OF ORIGINALITY IS THAT WHICH COMES AFTER A SOUND APPRENTICESHIP; THAT WHICH SHALL PROVE TO BE THE BLENDING OF A FIRM CONCEPTION OF ALL USEFUL PRECEDENT AND THE PROGRESSIVE TENDENCIES OF AN ABLE MIND. FOR, LET A MAN BE AS ABLE AND ORIGINAL AS HE MAY, HE CANNOT AFFORD TO DISCARD A KNOWLEDGE OF WHAT HAS GONE BEFORE OR WHAT IS NOW GOING ON IN HIS OWN TRADE AND PROFESSION. IF THE PRINTERS OF TODAY DO NOT

Nos. 1 and 4

THE BEST KIND OF ORIGINALITY IS THAT WHICH COMES AFTER A SOUND APPRENTICESHIP; THAT WHICH SHALL PROVE TO BE THE BLENDING OF A FIRM CONCEPTION OF ALL USEFUL PRECEDENT AND THE PROGRESSIVE TENDENCIES OF AN ABLE MIND. FOR, LET A MAN BE AS ABLE AND ORIGINAL AS HE MAY, HE CANNOT AFFORD TO DISCARD A KNOWLEDGE OF WHAT HAS GONE BEFORE OR WHAT IS NOW GOING ON IN HIS OWN TRADE AND HIS PROFESSION. IF THE PRINTERS OF TODAY DO NOT WISH TO BE ESTEEMED ARROGANT WHEN THEY TERM

Nos. 2 and 3

THE BEST KIND OF ORIGINALITY IS THAT WHICH COMES AFTER A SOUND APPRENTICESHIP; THAT WHICH SHALL PROVE TO BE THE BLENDING OF A FIRM CONCEPTION OF ALL USEFUL PRECEDENT AND THE PROGRESSIVE TENDENCIES OF AN ABLE MIND. FOR, LET A MAN BE AS ABLE AND ORIGINAL AS HE MAY, HE CANNOT AFFORD TO DISCARD A KNOWLEDGE OF WHAT HAS GONE BEFORE OR WHAT IS NOW GOING ON IN HIS OWN TRADE AND PROFESSION. IF THE PRINTERS OF TODAY DO NOT

Nos. 2 and 4

THE BEST KIND OF ORIGINALITY IS THAT WHICH COMES AFTER A SOUND APPRENTICESHIP; THAT WHICH SHALL PROVE TO BE THE BLENDING OF A FIRM CONCEPTION OF ALL USEFUL PRECEDENT AND OF THE PROGRESSIVE TENDENCIES OF AN ABLE MIND. FOR, LET A MAN BE AS ABLE AND ORIGINAL AS HE MAY, HE CANNOT AFFORD TO DISCARD A KNOWLEDGE OF WHAT HAS GONE BEFORE OR WHAT IS NOW GOING ON IN HIS OWN TRADE AND PROFESSION. IF THE PRINTERS OF TODAY DO NOT WISH TO BE ESTEEMED ARROGANT WHEN THEY TERM THIS CALL

Nos. 3 and 4

THE BEST KIND OF ORIGINALITY IS THAT WHICH COMES AFTER A SOUND APPRENTICESHIP; THAT WHICH SHALL PROVE TO BE THE BLENDING OF A FIRM CONCEPTION OF ALL USEFUL PRECEDENT AND THE PROGRESSIVE TENDENCIES OF AN ABLE MIND. FOR, LET A MAN BE AS ABLE AND ORIGINAL AS HE MAY, HE CANNOT AFFORD TO DISCARD A KNOWLEDGE OF WHAT HAS GONE BEFORE OR WHAT IS NOW GOING ON IN HIS OWN TRADE AND PROFESSION. IF THE PRINTERS OF TODAY DO NOT WISH TO BE ESTEEMED ARROGANT WHEN THEY TERM THIS CALLING OF

12 Point No. 340J, 11 Set

Nos. 1 and 2

THE BEST KIND OF ORIGINALITY IS THAT WHICH COMES AFTER A SOUND APPRENTICESHIP; THAT WHICH SHALL PROVE TO BE THE BLENDING OF A FIRM CONCEPTION OF ALL USEFUL PRECEDENT AND THE PRO-

Nos. 1 and 3

THE BEST KIND OF ORIGINALITY IS THAT WHICH COMES AFTER A SOUND APPRENTICESHIP; THAT WHICH SHALL PROVE TO BE THE BLENDING OF A FIRM CONCEPTION OF ALL USEFUL PRECEDENT AND THE PROGRESSIVE TENDENCIES OF AN ABLE

Nos. 1 and 4

THE VERY BEST KIND OF ORIGINALITY IS THAT WHICH COMES AFTER A SOUND APPRENTICESHIP; IT IS THAT WHICH SHALL PROVE TO BE THE BLENDING OF A FIRM CONCEPTION OF ALL USEFUL PRECEDENT AND THE PROGRESSIVE TENDENCIES OF AN ABLE MIND. FOR, LET

Nos. 2 and 3

THE BEST KIND OF ORIGINALITY IS THAT WHICH COMES AFTER A SOUND APPRENTICESHIP; THAT WHICH SHALL PROVE TO BE THE BLENDING OF A FIRM CONCEPTION OF ALL USEFUL PRECEDENT AND THE PROGRESSIVE TENDENCIES OF AN ABLE

Nos. 2 and 4

THE BEST KIND OF ORIGINALITY IS THAT WHICH COMES AFTER A SOUND APPRENTICESHIP; THAT WHICH SHALL PROVE TO BE THE BLENDING OF A FIRM CONCEPTION OF ALL USEFUL PRECEDENT AND THE PROGRESSIVE TENDENCIES OF AN ABLE MIND. FOR, LET A MAN BE AS

Nos. 3 and 4

THE BEST KIND OF ORIGINALITY IS THAT WHICH COMES AFTER A SOUND APPRENTICESHIP; THAT WHICH SHALL PROVE TO BE THE BLENDING OF A FIRM CONCEPTION OF ALL USEFUL PRECEDENT AND OF THE PROGRESSIVE TENDENCIES OF AN ABLE MIND. FOR, LET A MAN BE AS

ELECTRO-DISPLAY MATRICES No. 187, shown on page four, are the same type design and are an extension of the 340J Series shown on this page

14 Point No. 187

NON-DISTRIBUTION  
THE SECRET TO THE SUCCESSFUL PRODUCTION  
OF GOOD PRINTING IS NEW TYPE  
\$1234567890

18 Point No. 187

DOUBLE AND TRIPLE  
JUSTIFICATIONS IN ONE MEASURE ARE  
EASY ON THE MONOTYPE  
\$1234567890

18H4 Point No. 187

THE COMPOSITOR'S  
DAILY TOIL WILL BE A PLEASURE  
WITH NEW TYPE  
\$1234567890

24 Point No. 187

SPECIAL COMBINATIONS  
OF FACES MAY BE HAD FOR  
INTRICATE JOBS  
\$1234567890

24H4 Point No. 187

THE MONOTYPE  
ELIMINATES THE COST  
OF DISTRIBUTION  
\$1234567890

ELECTRO-DISPLAY MATRICES No. 187, shown on this page, are the same type design and are an extension of the 340J Series shown on pages two and three

# PLATE-GOTHIC No. 341J SERIES

## COMPOSITION MATRICES

**T**HE Plate-Gothics are so arranged that all four sizes of six-point are carried in one Matrix Case and, similarly, all four sizes of twelve-point are carried in one Matrix Case. Thus, four sizes may be composed at one operation on the Style D Keyboard, or eight sizes on the Duplex Keyboard, and cast in justified lines on the Casting Machine. At the Keyboard the right and left Keybars and Keybanks P-G and the Stopbars S108 are required, and at the Casting Machine the Normal Wedge S108 is required. A five-unit high space is required before the M and W of both six- and twelve-point No. 1 size of the 341J series.

Both six-point and twelve-point fonts will line when cast in composition on the same Mold, but to justify the six-point with the twelve-point, when setting by hand, the following plan has been adopted: The twelve-point remains on its standard line, .1250, but the six-point is cast to .0697 line. The six-point is then justified to the twelve-point by placing four points above and two points below the six-point type. Electro-Display Matrices of the No. 197 series, shown on page 4, are the same type design and are an extension of this 341J series and justify with twelve-point by point justification. To justify together the twelve-, fourteen-, eighteen-, and twenty-four-point sizes, place all the spacing at the top. This makes all sizes line. The comma, semi-colon, and tail of the Cap Q of the eighteen- and twenty-four-point sizes will overhang the body slightly, and there will be a slight overhang at the top of the 18H4 and 24H4 sizes.

This plan for point line justifying all sizes of the Plate-Gothic for hand composition applies to all series of Plate-Gothics now ready and those that may be added in the future. The line standards for casting type for hand composition for Plate-Gothics according to the above plan will be as follows:

|              |                  |                   |       |
|--------------|------------------|-------------------|-------|
| Six-point    | .0697            | Fourteen-point    | .1527 |
| Twelve-point | .1250 (Standard) | Eighteen-point    | .2088 |
|              |                  | Twenty-four-point | .2910 |

The Draw Rod should be readjusted to suit the movement of the Centering Pin when running on special line adjustment in order to produce the point line justification.

## ORATION

CTER OF FACILITIES  
OR DEPARTMENT OF  
ICH COULD NOT BE  
ERATIVE MATERIAL  
IF OUR OWN STOCK  
IN FURNITURE. IT  
AUTHENTIC REPRO-  
HE SALE OF MANY  
N ROOMS OF MANY  
PAPERS, HANGINGS  
ARE CONSTANTLY  
R MAKING SPECIAL  
UNIQUE THINGS TO  
UE VITAL TOUCH OF  
KED INDIVIDUALITY  
CORATIVE SECTION  
ALLERIES  
STREET

MR. AND MRS. W. D. BURDINE

AT HOME  
439 72D STREET, N. E.

RETURN IN TEN DAYS TO  
BLAKE PUBLISHING CO.  
460 GARFIELD AVENUE  
CLEVELAND



# No. 341J. Arrangement P-G—Composition Matrices

Specimens of the four sizes contained in each matrix case, each size shown separately

12 Point No. 341J, 9 Set

No. 1

THE BEST KIND OF ORIGINALITY IS THAT WHICH COMES AFTER A SOUND APPRENTICESHIP; THAT WHICH SHALL PROVE TO BE THE BLENDING OF A FIRM CONCEPTION OF ALL USEFUL PRECEDENT AND THE PROGRESSIVE TENDENCIES OF AN ABLE MIND. FOR, LET A MAN BE AS ABLE AND ORIGINAL AS HE MAY,

ABCDEFGHIJKLMN OPQRSTUVWXYZ

\$1234567890

No. 2

THE BEST KIND OF ORIGINALITY IS THAT WHICH COMES AFTER A SOUND APPRENTICESHIP; THAT WHICH SHALL PROVE TO BE THE BLENDING OF A FIRM CONCEPTION OF ALL USEFUL PRECEDENT AND THE PROGRESSIVE TENDENCIES OF AN ABLE MIND. FOR, LET A MAN BE AS ABLE AND ORIGINAL AS HE MAY, HE CANNOT AFFORD TO DISCARD A KNOWLEDGE

ABCDEFGHIJKLMN OPQRSTUVWXYZ

\$1234567890

No. 3

THE BEST KIND OF ORIGINALITY IS THAT WHICH COMES AFTER A SOUND APPRENTICESHIP; THAT WHICH SHALL PROVE TO BE THE BLENDING OF A FIRM CONCEPTION OF ALL USEFUL PRECEDENT AND THE PROGRESSIVE TENDENCIES OF AN ABLE MIND. FOR, LET A MAN BE AS ABLE AND ORIGINAL AS HE MAY, HE CANNOT AFFORD TO DISCARD A KNOWLEDGE OF WHAT HAS GONE BEFORE OR WHAT IS NOW GOING ON IN HIS

ABCDEFGHIJKLMN OPQRSTUVWXYZ

\$1234567890

No. 4

THE BEST KIND OF ORIGINALITY IS THAT WHICH COMES AFTER A SOUND APPRENTICESHIP; THAT WHICH SHALL PROVE TO BE THE BLENDING OF A FIRM CONCEPTION OF ALL USEFUL PRECEDENT AND THE PROGRESSIVE TENDENCIES OF AN ABLE MIND. FOR, LET A MAN BE AS ABLE AND ORIGINAL AS HE MAY, HE CANNOT AFFORD TO DISCARD A KNOWLEDGE OF WHAT HAS GONE BEFORE OR WHAT IS NOW GOING ON IN HIS OWN TRADE AND PROFESSION. IF THE PRINTERS OF TODAY DO NOT WISH

ABCDEFGHIJKLMN OPQRSTUVWXYZ

\$1234567890

6 Point No. 341J, 5 Set

No. 1

THE BEST KIND OF ORIGINALITY IS THAT WHICH COMES AFTER A SOUND APPRENTICESHIP; THAT WHICH SHALL PROVE TO BE THE BLENDING OF A FIRM CONCEPTION OF ALL USEFUL PRECEDENT AND THE PROGRESSIVE TENDENCIES OF AN ABLE MIND. FOR, LET A MAN BE AS ABLE AND ORIGINAL AS HE MAY, HE CANNOT AFFORD TO DISCARD KNOWLEDGE OF WHAT HAS GONE BEFORE OR WHAT IS NOW GOING ON IN HIS OWN TRADE AND PROFESSION. IF THE PRINTERS OF TODAY DO NOT WISH TO BE ESTEEMED ARROGANT WHEN THEY TERM THIS CALLING OF THEIRS AN ART, THEY MUST BE WILLING, AND SHOW THAT THEY ARE WILLING, TO SUBJECT IT TO SUCH LAWS AS HAVE MADE ITS SISTER ARTS SO FREE. ALL THOSE CONCERNED IN WHAT ARE ACCEPTED AS THE FINE ARTS, THE LEARNED SCIENCES, AND THE PROFESSIONS SURROUND THEM-

ABCDEFGHIJKLMN OPQRSTUVWXYZ

\$1234567890

No. 2

THE BEST KIND OF ORIGINALITY IS THAT WHICH COMES AFTER A SOUND APPRENTICESHIP; THAT WHICH SHALL PROVE TO BE THE BLENDING OF A FIRM CONCEPTION OF ALL USEFUL PRECEDENT AND THE PROGRESSIVE TENDENCIES OF AN ABLE MIND. FOR, LET A MAN BE AS ABLE AND ORIGINAL AS HE MAY, HE CANNOT AFFORD TO DISCARD KNOWLEDGE OF WHAT HAS GONE BEFORE OR WHAT IS NOW GOING ON IN HIS OWN TRADE AND PROFESSION. IF THE PRINTERS OF TODAY DO NOT WISH TO BE ESTEEMED ARROGANT WHEN THEY TERM THIS CALLING OF THEIRS AN ART, THEY MUST BE WILLING, AND SHOW THAT THEY ARE WILLING, TO SUBJECT IT TO SUCH LAWS AS HAVE MADE ITS SISTER ARTS SO FREE. ALL THOSE CONCERNED IN WHAT ARE ACCEPTED AS THE FINE ARTS, THE LEARNED SCIENCES, AND THE PROFESSIONS SURROUND THEMSELVES WITH THE HISTORY, LITERATURE, AND THE CONCRETE EXAMPLES OF THE WORK WITH WHICH THEY ARE PARTICULARLY

ABCDEFGHIJKLMN OPQRSTUVWXYZ

\$1234567890

No. 3

THE BEST KIND OF ORIGINALITY IS THAT WHICH COMES AFTER A SOUND APPRENTICESHIP; THAT WHICH SHALL PROVE TO BE THE BLENDING OF A FIRM CONCEPTION OF ALL USEFUL PRECEDENT AND THE PROGRESSIVE TENDENCIES OF AN ABLE MIND. FOR, LET A MAN BE AS ABLE AND ORIGINAL AS HE MAY, HE CANNOT AFFORD TO DISCARD KNOWLEDGE OF WHAT HAS GONE BEFORE OR WHAT IS NOW GOING ON IN HIS OWN TRADE AND PROFESSION. IF THE PRINTERS OF TODAY DO NOT WISH TO BE ESTEEMED ARROGANT WHEN THEY TERM THIS CALLING OF THEIRS AN ART, THEY MUST BE WILLING, AND SHOW THAT THEY ARE WILLING, TO SUBJECT IT TO SUCH LAWS AS HAVE MADE ITS SISTER ARTS SO FREE. ALL THOSE CONCERNED IN WHAT ARE ACCEPTED AS THE FINE ARTS, THE LEARNED SCIENCES, AND THE PROFESSIONS SURROUND THEMSELVES WITH THE HISTORY, LITERATURE, AND THE CONCRETE EXAMPLES OF THE WORK WITH WHICH THEY ARE PARTICULARLY ENGAGED. YET IT IS ONLY IN VERY RARE INSTANCES THAT SUCH AN ATMOSPHERE, WITH ITS MATERIAL APPURTENANCES, IS TO BE FOUND IN A PRINTING OFFICE. ART DOES NOT

ABCDEFGHIJKLMN OPQRSTUVWXYZ

\$1234567890

No. 4

THE BEST KIND OF ORIGINALITY IS THAT WHICH COMES AFTER A SOUND APPRENTICESHIP; THAT WHICH SHALL PROVE TO BE THE BLENDING OF A FIRM CONCEPTION OF ALL USEFUL PRECEDENT AND THE PROGRESSIVE TENDENCIES OF AN ABLE MIND. FOR, LET A MAN BE AS ABLE AND ORIGINAL AS HE MAY, HE CANNOT AFFORD TO DISCARD KNOWLEDGE OF WHAT HAS GONE BEFORE OR WHAT IS NOW GOING ON IN HIS OWN TRADE AND PROFESSION. IF THE PRINTERS OF TODAY DO NOT WISH TO BE ESTEEMED ARROGANT WHEN THEY TERM THIS CALLING OF THEIRS AN ART, THEY MUST BE WILLING, AND SHOW THAT THEY ARE WILLING, TO SUBJECT IT TO SUCH LAWS AS HAVE MADE ITS SISTER ARTS SO FREE. ALL THOSE CONCERNED IN WHAT ARE ACCEPTED AS THE FINE ARTS, THE LEARNED SCIENCES, AND THE PROFESSIONS SURROUND THEMSELVES WITH THE HISTORY, LITERATURE, AND THE CONCRETE EXAMPLES OF THE WORK WITH WHICH THEY ARE PARTICULARLY ENGAGED. YET IT IS ONLY IN VERY RARE INSTANCES THAT SUCH AN ATMOSPHERE, WITH ITS MATERIAL APPURTENANCES, IS TO BE FOUND IN A PRINTING OFFICE. ART DOES NOT FLOURISH IN HIDDEN PLACES, NOR UNDER RESTRAINT, NOR IN IGNORANCE OF WHAT TALENT

ABCDEFGHIJKLMN OPQRSTUVWXYZ

\$1234567890

ELECTRO-DISPLAY MATRICES No. 197, shown on page four, are the same type design and are an extension of the 341J Series shown on this page

## No. 341J. Arrangement P-G—Composition Matrices

Specimens of all the possible cap and small cap combinations that can be made with the four sizes in each matrix case

6 Point No. 341J, 5 Set

Nos. 1 and 2

THE BEST KIND OF ORIGINALITY IS THAT WHICH COMES AFTER A SOUND APPRENTICESHIP; THAT WHICH SHALL PROVE TO BE THE BLENDING OF A FIRM CONCEPTION OF ALL USEFUL PRECEDENT AND THE PROGRESSIVE TENDENCIES OF AN ABLE MIND. FOR, LET A MAN BE AS ABLE AND ORIGINAL AS HE MAY, HE CANNOT AFFORD TO DISCARD KNOWLEDGE OF WHAT HAS GONE BEFORE OR WHAT IS NOW GOING ON IN HIS OWN TRADE AND PROFESSION. IF THE PRINTERS OF TODAY DO NOT WISH TO BE ESTEEMED ARROGANT WHEN THEY TERM THIS CALLING OF THEIRS AN ART, THEY MUST BE WILLING, AND SHOW

Nos. 1 and 3

THE BEST KIND OF ORIGINALITY IS THAT WHICH COMES AFTER A SOUND APPRENTICESHIP; THAT WHICH SHALL PROVE TO BE THE BLENDING OF A FIRM CONCEPTION OF ALL USEFUL PRECEDENT AND THE PROGRESSIVE TENDENCIES OF AN ABLE MIND. FOR, LET A MAN BE AS ABLE AND ORIGINAL AS HE MAY, HE CANNOT AFFORD TO DISCARD KNOWLEDGE OF WHAT HAS GONE BEFORE OR WHAT IS NOW GOING ON IN HIS OWN TRADE AND PROFESSION. IF THE PRINTERS OF TODAY DO NOT WISH TO BE ESTEEMED ARROGANT WHEN THEY TERM THIS CALLING OF THEIRS AN ART, THEY MUST BE WILLING, AND SHOW THAT THEY ARE WILLING, TO SUBJECT IT TO SUCH LAWS AS HAVE

Nos. 1 and 4

THE BEST KIND OF ORIGINALITY IS THAT WHICH COMES AFTER A SOUND APPRENTICESHIP; THAT WHICH SHALL PROVE TO BE THE BLENDING OF A FIRM CONCEPTION OF ALL USEFUL PRECEDENT AND THE PROGRESSIVE TENDENCIES OF AN ABLE MIND. FOR, LET A MAN BE AS ABLE AND ORIGINAL AS HE MAY, HE CANNOT AFFORD TO DISCARD KNOWLEDGE OF WHAT HAS GONE BEFORE OR WHAT IS NOW GOING ON IN HIS OWN TRADE AND PROFESSION. IF THE PRINTERS OF TODAY DO NOT WISH TO BE ESTEEMED ARROGANT WHEN THEY TERM THIS CALLING OF THEIRS AN ART, THEY MUST BE WILLING, AND SHOW THAT THEY ARE WILLING, TO SUBJECT IT TO SUCH LAWS AS HAVE MADE ITS SISTER ARTS SO FREE. ALL THOSE CONCERNED IN WHAT ARE ACCEPTED AS

Nos. 2 and 3

THE BEST KIND OF ORIGINALITY IS THAT WHICH COMES AFTER A SOUND APPRENTICESHIP; THAT WHICH SHALL PROVE TO BE THE BLENDING OF A FIRM CONCEPTION OF ALL USEFUL PRECEDENT AND THE PROGRESSIVE TENDENCIES OF AN ABLE MIND. FOR, LET A MAN BE AS ABLE AND ORIGINAL AS HE MAY, HE CANNOT AFFORD TO DISCARD KNOWLEDGE OF WHAT HAS GONE BEFORE OR WHAT IS NOW GOING ON IN HIS OWN TRADE AND PROFESSION. IF THE PRINTERS OF TODAY DO NOT WISH TO BE ESTEEMED ARROGANT WHEN THEY TERM THIS CALLING OF THEIRS AN ART, THEY MUST BE WILLING, AND SHOW THAT THEY ARE WILLING, TO SUBJECT IT TO SUCH LAWS AS

Nos. 2 and 4

THE BEST KIND OF ORIGINALITY IS THAT WHICH COMES AFTER A SOUND APPRENTICESHIP; THAT WHICH SHALL PROVE TO BE THE BLENDING OF A FIRM CONCEPTION OF ALL USEFUL PRECEDENT AND THE PROGRESSIVE TENDENCIES OF AN ABLE MIND. FOR, LET A MAN BE AS ABLE AND ORIGINAL AS HE MAY, HE CANNOT AFFORD TO DISCARD KNOWLEDGE OF WHAT HAS GONE BEFORE OR WHAT IS NOW GOING ON IN HIS OWN TRADE AND PROFESSION. IF THE PRINTERS OF TODAY DO NOT WISH TO BE ESTEEMED ARROGANT WHEN THEY TERM THIS CALLING OF THEIRS AN ART, THEY MUST BE WILLING, AND SHOW THAT THEY ARE WILLING, TO SUBJECT IT TO SUCH LAWS AS HAVE MADE ITS SISTER ARTS SO FREE. ALL THOSE CONCERNED IN WHAT ARE ACCEPTED AS THE FINE ARTS,

Nos. 3 and 4

THE BEST KIND OF ORIGINALITY IS THAT WHICH COMES AFTER A SOUND APPRENTICESHIP; THAT WHICH SHALL PROVE TO BE THE BLENDING OF A FIRM CONCEPTION OF ALL USEFUL PRECEDENT AND THE PROGRESSIVE TENDENCIES OF AN ABLE MIND. FOR, LET A MAN BE AS ABLE AND ORIGINAL AS HE MAY, HE CANNOT AFFORD TO DISCARD KNOWLEDGE OF WHAT HAS GONE BEFORE OR WHAT IS NOW GOING ON IN HIS OWN TRADE AND PROFESSION. IF THE PRINTERS OF TODAY DO NOT WISH TO BE ESTEEMED ARROGANT WHEN THEY TERM THIS CALLING OF THEIRS AN ART, THEY MUST BE WILLING, AND SHOW THAT THEY ARE WILLING, TO SUBJECT IT TO SUCH LAWS AS HAVE MADE ITS SISTER ARTS SO FREE. ALL THOSE CONCERNED IN WHAT ARE ACCEPTED AS THE FINE ARTS, THE LEARNED

12 Point No. 341J, 9 Set

Nos. 1 and 2

THE BEST KIND OF ORIGINALITY IS THAT WHICH COMES AFTER A SOUND APPRENTICESHIP; THAT WHICH SHALL PROVE TO BE THE BLENDING OF A FIRM CONCEPTION OF ALL USEFUL PRECEDENT AND THE PROGRESSIVE TENDENCIES OF AN ABLE MIND.

Nos. 1 and 3

THE BEST KIND OF ORIGINALITY IS THAT WHICH COMES AFTER A SOUND APPRENTICESHIP; THAT WHICH SHALL PROVE TO BE THE BLENDING OF A FIRM CONCEPTION OF ALL USEFUL PRECEDENT AND THE PROGRESSIVE TENDENCIES OF AN ABLE MIND. FOR, LET A MAN BE AS ABLE AND

Nos. 1 and 4

THE BEST KIND OF ORIGINALITY IS THAT WHICH COMES AFTER A SOUND APPRENTICESHIP; THAT WHICH SHALL PROVE TO BE THE BLENDING OF A FIRM CONCEPTION OF ALL USEFUL PRECEDENT AND THE PROGRESSIVE TENDENCIES OF AN ABLE MIND. FOR, LET A MAN BE AS ABLE AND ORIGINAL AS HE MAY, HE CANNOT AFFORD

Nos. 2 and 3

THE BEST KIND OF ORIGINALITY IS THAT WHICH COMES AFTER A SOUND APPRENTICESHIP; THAT WHICH SHALL PROVE TO BE THE BLENDING OF A FIRM CONCEPTION OF ALL USEFUL PRECEDENT AND THE PROGRESSIVE TENDENCIES OF AN ABLE MIND; FOR, LET A MAN BE AS ABLE AND ORIG-

Nos. 2 and 4

THE BEST KIND OF ORIGINALITY IS THAT WHICH COMES AFTER A SOUND APPRENTICESHIP; THAT WHICH SHALL PROVE TO BE THE BLENDING OF A FIRM CONCEPTION OF ALL USEFUL PRECEDENT AND THE PROGRESSIVE TENDENCIES OF AN ABLE MIND. FOR, LET A MAN BE AS ABLE AND ORIGINAL AS HE MAY, HE CANNOT AFFORD TO

Nos. 3 and 4

THE BEST KIND OF ORIGINALITY IS THAT WHICH COMES AFTER A SOUND APPRENTICESHIP; THAT WHICH SHALL PROVE TO BE THE BLENDING OF A FIRM CONCEPTION OF ALL USEFUL PRECEDENT AND THE PROGRESSIVE TENDENCIES OF AN ABLE MIND. FOR, LET A MAN BE AS ABLE AND ORIGINAL AS HE MAY, HE CANNOT AFFORD TO DIS-

ELECTRO-DISPLAY MATRICES No. 197, shown on page four, are the same type design and are an extension of the 341J Series shown on this page.

14 Point No. 197

THE AUTOMATIC CASTING MACHINE  
RUNS AT THE MAXIMUM SPEED REGARDLESS OF WHETHER  
THE MATTER BE PLAIN OR INTRICATE  
\$1234567890

18 Point No. 197

MONOTYPE OPERATORS HIT KEYS  
AT THE MAXIMUM SPEED AND ARE NOT SLOWED-  
UP BY MECHANICAL PROBLEMS  
\$1234567890

18H4 Point No. 197

QUALITY PAYS  
IT IS THE ONLY SOLID FOUNDATION ON  
WHICH TO BUILD A BUSINESS  
\$1234567890

24 Point No. 197

NO SLOW SPOTS  
ON THE MONOTYPE—THE ACTION OF  
EVERY KEY IS IDENTICAL  
\$1234567890

24H4 Point No. 197

EACH LETTER  
IN MONOTYPE COMPOSITION IS  
CAST SEPARATELY  
\$1234567890

ELECTRO-DISPLAY MATRICES No. 197, shown on this page, are the same type design and are an extension of the 341J Series shown on pages two and three

# PLATE-GOTHIC No. 342J SERIES

## COMPOSITION MATRICES



### MENU

OYSTER COCKTAILS

BLUE POINTS  
WAFERS

CREAM OF LETTUCE  
SALTED ALMONDS

WHITE BAIT, TARTAR SAUCE  
SWEET POTATOES  
CELERY                      RADISHES                      OLIVES

TENDERLOIN OF BEEF  
MASHED POTATOES AND GREEN PEAS

ROMAN PUNCH

ROAST MALLARD DUCK  
FRIED HOMINY                      SARATOGA CHIPS

ICE CREAM  
ASSORTED CAKE  
CHEESE AND CRACKERS

**T**HE Plate-Gothics are so arranged that all four sizes of six-point are carried in one Matrix Case and, similarly, all four sizes of twelve-point are carried in one Matrix Case. Thus, four sizes may be composed at one operation on the Style D Keyboard, or eight sizes on the Duplex Keyboard, and cast in justified lines on the Casting Machine. At the Keyboard the right and left Keybars and Keybanks P-G and the Stopbars S108 are required, and at the Casting Machine the Normal Wedge S108 is required. A five-unit high space is required before the M and W of both six- and twelve-point No. 1 size of the 342J series.

Both six-point and twelve-point fonts will line when cast in composition on the same Mold, but to justify the six-point with the twelve-point, when setting by hand, the following plan has been adopted: The twelve-point remains on its standard line, .1250, but the six-point is cast to .0697 line. The six-point is then justified to the twelve-point by placing four points above and two points below the six-point type. Electro-Display Matrices of the No. 168 series, shown on page 4, are the same type design and are an extension of this 342J series and justify with twelve-point by point justification. To justify together the twelve-, fourteen-, eighteen-, and twenty-four-point sizes, place all the spacing at the top. This makes all sizes line. The comma, semi-colon, and tail of the Cap Q of the eighteen- and twenty-four-point sizes will overhang the body slightly, and there will be a slight overhang at the top of the 18H4 and 24H4 sizes.

This plan for point line justifying all sizes of the Plate-Gothic for hand composition applies to all series of Plate-Gothics now ready and those that may be added in the future. The line standards for casting type for hand composition for Plate-Gothics according to the above plan will be as follows:

|                   |                  |
|-------------------|------------------|
| Six-point         | .0697            |
| Twelve-point      | .1250 (Standard) |
| Fourteen-point    | .1527            |
| Eighteen-point    | .2000            |
| Twenty-four-point | .2910            |

The Draw Rod should be readjusted to suit the movement of the Centering Pin when running on special line adjustment in order to produce the point line justification.

JOHN ALDINE, PRES.

ALFRED SEEMORE, SEC'Y AND TREAS.

HARRY BELDING, VICE-PRES.

SECRETARY'S OFFICE

MOBILE UNDERWRITERS INSURANCE COMPANY

SUITE 3010 AND 3011

CHAMBER OF COMMERCE BUILDING

VESPER, IDAHO.

# No. 342J. Arrangement P-G—Composition Matrices

Specimens of the four sizes contained in each matrix case, each size shown separately

12 Point No. 342J, 11 Set

No. 1

THE BEST KIND OF ORIGINALITY IS THAT WHICH COMES AFTER A SOUND APPRENTICESHIP; THAT WHICH SHALL PROVE TO BE THE BLENDING OF A FIRM CONCEPTION OF ALL USEFUL PRECEDENT AND THE PROGRESSIVE TENDENCIES OF AN ABLE MIND. FOR,

ABCDEFGHIJKLMN OPQRSTUVWXYZ

\$1234567890

No. 2

THE BEST KIND OF ORIGINALITY IS THAT WHICH COMES AFTER A SOUND APPRENTICESHIP; THAT WHICH SHALL PROVE TO BE THE BLENDING OF A FIRM CONCEPTION OF ALL USEFUL PRECEDENT AND THE PROGRESSIVE TENDENCIES OF AN ABLE MIND. FOR, LET A MAN BE AS ABLE AND ORIGINAL

ABCDEFGHIJKLMN OPQRSTUVWXYZ

\$1234567890

No. 3

THE BEST KIND OF ORIGINALITY IS THAT WHICH COMES AFTER A SOUND APPRENTICESHIP; THAT WHICH SHALL PROVE TO BE THE BLENDING OF A FIRM CONCEPTION OF ALL USEFUL PRECEDENT AND THE PROGRESSIVE TENDENCIES OF AN ABLE MIND. FOR, LET A MAN BE AS ABLE AND ORIGINAL AS HE MAY, HE CANNOT AFFORD TO DISCARD

ABCDEFGHIJKLMN OPQRSTUVWXYZ

\$1234567890

No. 4

THE BEST KIND OF ORIGINALITY IS THAT WHICH COMES AFTER A SOUND APPRENTICESHIP; THAT WHICH SHALL PROVE TO BE THE BLENDING OF A FIRM CONCEPTION OF ALL USEFUL PRECEDENT AND THE PROGRESSIVE TENDENCIES OF AN ABLE MIND. FOR, LET A MAN BE AS ABLE AND ORIGINAL AS HE MAY, HE CANNOT AFFORD TO DISCARD A KNOWLEDGE OF WHAT HAS GONE BEFORE OR WHAT IS

ABCDEFGHIJKLMN OPQRSTUVWXYZ

\$1234567890

6 Point No. 342J, 7 Set

No. 1

THE BEST KIND OF ORIGINALITY IS THAT WHICH COMES AFTER A SOUND APPRENTICESHIP; THAT WHICH SHALL PROVE TO BE THE BLENDING OF A FIRM CONCEPTION OF ALL USEFUL PRECEDENT AND THE PROGRESSIVE TENDENCIES OF AN ABLE MIND. FOR, LET A MAN BE AS ABLE AND ORIGINAL AS HE MAY, HE CANNOT AFFORD TO DISCARD KNOWLEDGE OF WHAT HAS GONE BEFORE OR WHAT IS NOW GOING ON IN HIS OWN TRADE AND PROFESSION. IF THE PRINTERS OF TODAY DO NOT WISH TO BE ESTEEMED ARROGANT WHEN THEY TERM THIS CALLING OF THEIRS AN ART, THEY MUST

ABCDEFGHIJKLMN OPQRSTUVWXYZ

\$1234567890

No. 2

THE BEST KIND OF ORIGINALITY IS THAT WHICH COMES AFTER A SOUND APPRENTICESHIP; THAT WHICH SHALL PROVE TO BE THE BLENDING OF A FIRM CONCEPTION OF ALL USEFUL PRECEDENT AND THE PROGRESSIVE TENDENCIES OF AN ABLE MIND. FOR, LET A MAN BE AS ABLE AND ORIGINAL AS HE MAY, HE CANNOT AFFORD TO DISCARD KNOWLEDGE OF WHAT HAS GONE BEFORE OR WHAT IS NOW GOING ON IN HIS OWN TRADE AND PROFESSION. IF THE PRINTERS OF TODAY DO NOT WISH TO BE ESTEEMED ARROGANT WHEN THEY TERM THIS CALLING OF THEIRS AN ART, THEY MUST BE WILLING, AND SHOW THAT THEY ARE WILLING, TO SUBJECT IT TO SUCH LAWS

ABCDEFGHIJKLMN OPQRSTUVWXYZ

\$1234567890

No. 3

THE BEST KIND OF ORIGINALITY IS THAT WHICH COMES AFTER A SOUND APPRENTICESHIP; THAT WHICH SHALL PROVE TO BE THE BLENDING OF A FIRM CONCEPTION OF ALL USEFUL PRECEDENT AND THE PROGRESSIVE TENDENCIES OF AN ABLE MIND. FOR, LET A MAN BE AS ABLE AND ORIGINAL AS HE MAY, HE CANNOT AFFORD TO DISCARD A KNOWLEDGE OF WHAT HAS GONE BEFORE OR WHAT IS NOW GOING ON IN HIS OWN TRADE AND PROFESSION. IF THE PRINTERS OF TODAY DO NOT WISH TO BE ESTEEMED ARROGANT WHEN THEY TERM THIS CALLING OF THEIRS AN ART, THEY MUST BE WILLING, AND SHOW THAT THEY ARE WILLING, TO SUBJECT IT TO SUCH LAWS AS HAVE MADE ITS SISTER ARTS SO FREE. ALL THOSE CONCERNED IN WHAT ARE ACCEPTED AS THE FINE ARTS, THE LEARNED

ABCDEFGHIJKLMN OPQRSTUVWXYZ

\$1234567890

No. 4

THE BEST KIND OF ORIGINALITY IS THAT WHICH COMES AFTER A SOUND APPRENTICESHIP; THAT WHICH SHALL PROVE TO BE THE BLENDING OF A FIRM CONCEPTION OF ALL USEFUL PRECEDENT AND THE PROGRESSIVE TENDENCIES OF AN ABLE MIND. FOR, LET A MAN BE AS ABLE AND ORIGINAL AS HE MAY, HE CANNOT AFFORD TO DISCARD A KNOWLEDGE OF WHAT HAS GONE BEFORE OR WHAT IS NOW GOING ON IN HIS OWN TRADE AND PROFESSION. IF THE PRINTERS OF TODAY DO NOT WISH TO BE ESTEEMED ARROGANT WHEN THEY TERM THIS CALLING OF THEIRS AN ART, THEY MUST BE WILLING, AND SHOW THAT THEY ARE WILLING, TO SUBJECT IT TO SUCH LAWS AS HAVE MADE ITS SISTER ARTS SO FREE. ALL THOSE CONCERNED IN WHAT ARE ACCEPTED AS THE FINE ARTS, THE LEARNED SCIENCES, AND PROFESSIONS SURROUND THEMSELVES WITH

ABCDEFGHIJKLMN OPQRSTUVWXYZ

\$1234567890

ELECTRO-DISPLAY MATRICES No. 166, shown on page four, are the same type design and are an extension of the 342J Series shown on this page

## No. 342J. Arrangement P-G—Composition Matrices

Specimens of all the possible cap and small cap combinations that can be made with the four sizes in each matrix case

6 Point No. 342J, 7 Set

Nos. 1 and 2

THE BEST KIND OF ORIGINALITY IS THAT WHICH COMES AFTER A SOUND APPRENTICESHIP; THAT WHICH SHALL PROVE TO BE THE BLENDING OF A FIRM CONCEPTION OF ALL USEFUL PRECEDENT AND THE PROGRESSIVE TENDENCIES OF AN ABLE MIND. FOR, LET A MAN BE AS ABLE AND ORIGINAL AS HE MAY, HE CANNOT AFFORD TO DISCARD KNOWLEDGE OF WHAT HAS GONE BEFORE OR WHAT IS NOW GOING ON IN HIS

12 Point No. 342J, 11 Set

Nos. 1 and 2

THE BEST KIND OF ORIGINALITY IS THAT WHICH COMES AFTER A SOUND APPRENTICESHIP; THAT WHICH SHALL PROVE TO BE THE BLENDING OF A FIRM CONCEPTION OF ALL USEFUL PRECEDENT AND THE PRO-

Nos. 1 and 3

THE BEST KIND OF ORIGINALITY IS THAT WHICH COMES AFTER A SOUND APPRENTICESHIP; THAT WHICH SHALL PROVE TO BE THE BLENDING OF A FIRM CONCEPTION OF ALL USEFUL PRECEDENT AND THE PROGRESSIVE TENDENCIES OF AN ABLE MIND. FOR, LET A MAN BE AS ABLE AND ORIGINAL AS HE MAY, HE CANNOT AFFORD TO DISCARD A KNOWLEDGE OF WHAT HAS GONE BEFORE OR WHAT IS NOW GOING ON IN HIS OWN TRADE AND PROFESSION. IF THE PRINTERS OF TODAY DO NOT

Nos. 1 and 3

THE BEST KIND OF ORIGINALITY IS THAT WHICH COMES AFTER A SOUND APPRENTICESHIP; THAT WHICH SHALL PROVE TO BE THE BLENDING OF A FIRM CONCEPTION OF ALL USEFUL PRECEDENT AND THE PROGRESSIVE TENDENCIES OF AN ABLE

Nos. 1 and 4

THE BEST KIND OF ORIGINALITY IS THAT WHICH COMES AFTER A SOUND APPRENTICESHIP; THAT WHICH SHALL PROVE TO BE THE BLENDING OF A FIRM CONCEPTION OF ALL USEFUL PRECEDENT AND THE PROGRESSIVE TENDENCIES OF AN ABLE MIND. FOR, LET A MAN BE AS ABLE AND ORIGINAL AS HE MAY, HE CANNOT AFFORD TO DISCARD KNOWLEDGE OF WHAT HAS GONE BEFORE OR WHAT IS NOW GOING ON IN HIS OWN TRADE AND PROFESSION. IF THE PRINTERS OF TODAY DO NOT WISH TO BE ESTEEMED ARROGANT WHEN THEY TERM

Nos. 1 and 4

THE BEST KIND OF ORIGINALITY IS THAT WHICH COMES AFTER A SOUND APPRENTICESHIP; THAT WHICH SHALL PROVE TO BE THE BLENDING OF A FIRM CONCEPTION OF ALL USEFUL PRECEDENT AND THE PROGRESSIVE TENDENCIES OF AN ABLE MIND. FOR, LET

Nos. 2 and 3

THE BEST KIND OF ORIGINALITY IS THAT WHICH COMES AFTER A SOUND APPRENTICESHIP; THAT WHICH SHALL PROVE TO BE THE BLENDING OF A FIRM CONCEPTION OF ALL USEFUL PRECEDENT AND THE PROGRESSIVE TENDENCIES OF AN ABLE MIND. FOR, LET A MAN BE AS ABLE AND ORIGINAL AS HE MAY, HE CANNOT AFFORD TO DISCARD A KNOWLEDGE OF WHAT HAS GONE BEFORE OR WHAT IS NOW GOING ON IN HIS OWN TRADE AND PROFESSION. IF THE PRINTERS OF TODAY DO NOT

Nos. 2 and 3

THE BEST KIND OF ORIGINALITY IS THAT WHICH COMES AFTER A SOUND APPRENTICESHIP; THAT WHICH SHALL PROVE TO BE THE BLENDING OF A FIRM CONCEPTION OF ALL USEFUL PRECEDENT AND THE PROGRESSIVE TENDENCIES OF AN ABLE

Nos. 2 and 4

THE BEST KIND OF ORIGINALITY IS THAT WHICH COMES AFTER A SOUND APPRENTICESHIP; THAT WHICH SHALL PROVE TO BE THE BLENDING OF A FIRM CONCEPTION OF ALL USEFUL PRECEDENT AND THE PROGRESSIVE TENDENCIES OF AN ABLE MIND. FOR, LET A MAN BE AS ABLE AND ORIGINAL AS HE MAY, HE CANNOT AFFORD TO DISCARD A KNOWLEDGE OF WHAT HAS GONE BEFORE OR WHAT IS NOW GOING ON IN HIS OWN TRADE AND PROFESSION. IF THE PRINTERS OF TODAY DO NOT WISH TO BE ESTEEMED ARROGANT WHEN THEY TERM THIS CALL-

Nos. 2 and 4

THE BEST KIND OF ORIGINALITY IS THAT WHICH COMES AFTER A SOUND APPRENTICESHIP; THAT WHICH SHALL PROVE TO BE THE BLENDING OF A FIRM CONCEPTION OF ALL USEFUL PRECEDENT AND THE PROGRESSIVE TENDENCIES OF AN ABLE MIND. FOR, LET A MAN BE AS

Nos. 3 and 4

THE BEST KIND OF ORIGINALITY IS THAT WHICH COMES AFTER A SOUND APPRENTICESHIP; THAT WHICH SHALL PROVE TO BE THE BLENDING OF A FIRM CONCEPTION OF ALL USEFUL PRECEDENT AND THE PROGRESSIVE TENDENCIES OF AN ABLE MIND. FOR, LET A MAN BE AS ABLE AND ORIGINAL AS HE MAY, HE CANNOT AFFORD TO DISCARD A KNOWLEDGE OF WHAT HAS GONE BEFORE OR WHAT IS NOW GOING ON IN HIS OWN TRADE AND PROFESSION. IF THE PRINTERS OF TODAY DO NOT WISH TO BE ESTEEMED ARROGANT WHEN THEY TERM THIS CALLING OF

Nos. 3 and 4

THE BEST KIND OF ORIGINALITY IS THAT WHICH COMES AFTER A SOUND APPRENTICESHIP; THAT WHICH SHALL PROVE TO BE THE BLENDING OF A FIRM CONCEPTION OF ALL USEFUL PRECEDENT AND THE PROGRESSIVE TENDENCIES OF AN ABLE MIND. FOR, LET A MAN BE AS

ELECTRO-DISPLAY MATRICES No. 168, shown on page four, are the same type design and are an extension of the 342J Series shown on this page

14 Point No. 168

**THE MONOTYPE  
CONTINUOUSLY RENEWS ALL THE PERISHABLE  
MATERIAL USED BY COMPOSITORS  
\$1234567890**

18 Point No. 168

**EVERY HOUR OF  
EVERY COMPOSITOR PRODUCTIVE WITH  
NON-DISTRIBUTION  
\$1234567890**

18H4 Point No. 168

**MERITS OF  
A MONOTYPE NON-DISTRIBUTION  
SYSTEM ARE IN EVIDENCE  
\$1234567890**

24 Point No. 168

**LEADS, SLUGS,  
QUADS AND SPACE MATERIAL  
IN UNLIMITED QUANTITIES  
\$1234567890**

24H4 Point No. 168

**FOR QUALITY  
ALWAYS USE MONOTYPE  
COMPOSITION  
\$1234567890**

ELECTRO-DISPLAY MATRICES No. 168, shown on this page, are the same type design and are an extension of the 342J Series shown on pages two and three

# PLATE-GOTHIC No. 343J SERIES

## COMPOSITION MATRICES

THIS NEW IDEA OF SETTING PLATE-GOTHICS ON THE MONOTYPE IN JUSTIFIED LINES IS ANOTHER OF THE MANY ECONOMIES OF THE MONOTYPE SYSTEM WHICH EXTENDS THE ADVANTAGES OF REAL MACHINE COMPOSITION TO THE KIND OF WORK THAT YOU ALWAYS THOUGHT HAD TO BE SET BY HAND. NOW YOU GET A BETTER PRODUCT FROM ALWAYS NEW MONOTYPE AT A MACHINE-SET COST.

LETTER HEADS  
BUSINESS CARDS  
ENVELOPES  
BILL HEADS  
STATEMENTS  
MENUS  
PROGRAMS  
DANCE CARDS  
ANNOUNCEMENTS  
TAGS



**P**ROFITS ARE NEVER  
MADE BY A PRINTER  
WHO IS STRUGGLING TO  
GET PRODUCTION FROM  
POOR EQUIPMENT

LACK OF PROPER FACILITIES FOR  
MAKING LABOR EFFECTIVE, AND  
THEREFORE PRODUCTIVE, CANNOT  
BE MADE UP BY DRIVING NOR BY  
CHEAPENING LABOR

PROFITS DEPEND UPON QUALITY AS  
WELL AS ON PRODUCTION

### THE MONOTYPE

MAKES EVERY WORKER IN THE COM-  
POSING ROOM A GREATER PRODUCER  
BY SUPPLYING HIM THE MATERIAL  
FOR AND THE INCENTIVE TO EFFI-  
CIENCY, AND IMPROVES THE QUALITY  
OF HIS WORK

DEPOSIT SLIPS  
PROMISSORY NOTES  
CHECKS  
CIRCULARS  
BOOKLETS  
RECEIPTS  
ORDER BLANKS  
BLANK FORMS  
ADVERTISEMENTS  
LABELS



**T**HE Plate-Gothics are so arranged that all four sizes of six-point are carried in one Matrix Case and, similarly, all four sizes of twelve-point are carried in one Matrix Case. Thus, four sizes may be composed at one operation on the Style D Keyboard, or eight sizes on the Duplex Keyboard, and cast in justified lines on the Casting Machine. At the Keyboard the right and left Keybars and Keybars P-G and the Stop-bars S108 are required, and at the Casting Machine the Normal Wedge S108 is required. A five-unit high space is required before the M and W of both six- and twelve-point No. 1 size of the 343J series.

Both six-point and twelve-point fonts will line when cast in composition on the same Mold, but to justify the six-point with the twelve-point, when setting by hand, the following plan has been adopted: The twelve-point remains on its standard line, .1250, but the six-point is cast to .0697 line. The six-point is then justified to the twelve-point by placing four points above and two points below the six-point type. Electro-Display Matrices of the No. 169 series, shown on page four, are the same type design and are an extension of this 343J series and justify with twelve-point by point justification. To justify together the twelve-, fourteen-, eighteen-, and twenty-four-point sizes, place all the spacing at the top. This makes all sizes line. The comma, semi-colon, and tail of the Cap Q of the eighteen- and twenty-four-point sizes will overhang the body slightly, and there will be a slight overhang at the top of the 18H4 and 24H4 sizes.

This plan for point line justifying all sizes of the Plate-Gothic for hand composition applies to all series of Plate-Gothics now ready and those that may be added in the future. The line standards for casting type for hand composition for Plate-Gothics according to the above plan will be as follows:

|              |                  |                   |       |
|--------------|------------------|-------------------|-------|
| Six-point    | .0697            | Fourteen-point    | .1527 |
| Twelve-point | .1250 (Standard) | Eighteen-point    | .2080 |
|              |                  | Twenty-four point | .2910 |

The Draw Rod should be readjusted to suit the movement of the Centering Pin when running on special line adjustment in order to produce the point line justification.



# No. 343J. Arrangement P-G—Composition Matrices

Specimens of the four sizes contained in each matrix case, each size shown separately

12 Point No. 343J, 9 Set

No. 1

THE BEST KIND OF ORIGINALITY IS THAT WHICH COMES AFTER A SOUND APPRENTICESHIP; THAT WHICH SHALL PROVE TO BE THE BLENDING OF A FIRM CONCEPTION OF ALL USEFUL PRECEDENT AND THE PROGRESSIVE TENDENCIES OF AN ABLE MIND. FOR, LET A MAN BE AS ABLE AND ORIGINAL AS HE MAY,

ABCDEFGHIJKLMN OPQRSTUVWXYZ

\$1234567890

No. 2

THE BEST KIND OF ORIGINALITY IS THAT WHICH COMES AFTER A SOUND APPRENTICESHIP; THAT WHICH SHALL PROVE TO BE THE BLENDING OF A FIRM CONCEPTION OF ALL USEFUL PRECEDENT AND THE PROGRESSIVE TENDENCIES OF AN ABLE MIND. FOR, LET A MAN BE AS ABLE AND ORIGINAL AS HE MAY, HE CANNOT AFFORD TO DISCARD A KNOWLEDGE

ABCDEFGHIJKLMN OPQRSTUVWXYZ

\$1234567890

No. 3

THE BEST KIND OF ORIGINALITY IS THAT WHICH COMES AFTER A SOUND APPRENTICESHIP; THAT WHICH SHALL PROVE TO BE THE BLENDING OF A FIRM CONCEPTION OF ALL USEFUL PRECEDENT AND THE PROGRESSIVE TENDENCIES OF AN ABLE MIND. FOR, LET A MAN BE AS ABLE AND ORIGINAL AS HE MAY, HE CANNOT AFFORD TO DISCARD A KNOWLEDGE OF WHAT HAS GONE BEFORE OR WHAT IS NOW GOING ON IN HIS

ABCDEFGHIJKLMN OPQRSTUVWXYZ

\$1234567890

No. 4

THE BEST KIND OF ORIGINALITY IS THAT WHICH COMES AFTER A SOUND APPRENTICESHIP; THAT WHICH SHALL PROVE TO BE THE BLENDING OF A FIRM CONCEPTION OF ALL USEFUL PRECEDENT AND THE PROGRESSIVE TENDENCIES OF AN ABLE MIND. FOR, LET A MAN BE AS ABLE AND ORIGINAL AS HE MAY, HE CANNOT AFFORD TO DISCARD A KNOWLEDGE OF WHAT HAS GONE BEFORE OR WHAT IS NOW GOING ON IN HIS OWN TRADE AND PROFESSION. IF THE PRINTERS OF TODAY DO NOT WISH

ABCDEFGHIJKLMN OPQRSTUVWXYZ

\$1234567890

6 Point No. 343J, 5 Set

No. 1

THE BEST KIND OF ORIGINALITY IS THAT WHICH COMES AFTER A SOUND APPRENTICESHIP; THAT WHICH SHALL PROVE TO BE THE BLENDING OF A FIRM CONCEPTION OF ALL USEFUL PRECEDENT AND THE PROGRESSIVE TENDENCIES OF AN ABLE MIND. FOR, LET A MAN BE AS ABLE AND ORIGINAL AS HE MAY, HE CANNOT AFFORD TO DISCARD KNOWLEDGE OF WHAT HAS GONE BEFORE OR WHAT IS NOW GOING ON IN HIS OWN TRADE AND PROFESSION. IF THE PRINTERS OF TODAY DO NOT WISH TO BE ESTEEMED ARROGANT WHEN THEY TERM THIS CALLING OF THEIRS AN ART, THEY MUST BE WILLING, AND SHOW THAT THEY ARE WILLING, TO SUBJECT IT TO SUCH LAWS AS HAVE MADE ITS SISTER ARTS SO FREE. ALL THOSE CONCERNED IN WHAT ARE ACCEPTED AS THE FINE ARTS, THE LEARNED SCIENCES, AND PROFESSIONS SUR-

ABCDEFGHIJKLMN OPQRSTUVWXYZ

\$1234567890

No. 2

THE BEST KIND OF ORIGINALITY IS THAT WHICH COMES AFTER A SOUND APPRENTICESHIP; THAT WHICH SHALL PROVE TO BE THE BLENDING OF A FIRM CONCEPTION OF ALL USEFUL PRECEDENT AND THE PROGRESSIVE TENDENCIES OF AN ABLE MIND. FOR, LET A MAN BE AS ABLE AND ORIGINAL AS HE MAY, HE CANNOT AFFORD TO DISCARD A KNOWLEDGE OF WHAT HAS GONE BEFORE OR WHAT IS NOW GOING ON IN HIS OWN TRADE AND PROFESSION. IF THE PRINTERS OF TODAY DO NOT WISH TO BE ESTEEMED ARROGANT WHEN THEY TERM THIS CALLING OF THEIRS AN ART, THEY MUST BE WILLING, AND SHOW THAT THEY ARE WILLING, TO SUBJECT IT TO SUCH LAWS AS HAVE MADE ITS SISTER ARTS SO FREE. ALL THOSE CONCERNED IN WHAT ARE ACCEPTED AS THE FINE ARTS, THE LEARNED SCIENCES, AND THE PROFESSIONS SURROUND THEMSELVES WITH THE HISTORY, LITERATURE, AND THE CONCRETE EXAMPLES OF THE WORK WITH WHICH THEY ARE PARTICULARLY

ABCDEFGHIJKLMN OPQRSTUVWXYZ

\$1234567890

No. 3

THE BEST KIND OF ORIGINALITY IS THAT WHICH COMES AFTER A SOUND APPRENTICESHIP; THAT WHICH SHALL PROVE TO BE THE BLENDING OF A FIRM CONCEPTION OF ALL USEFUL PRECEDENT AND THE PROGRESSIVE TENDENCIES OF AN ABLE MIND. FOR, LET A MAN BE AS ABLE AND ORIGINAL AS HE MAY, HE CANNOT AFFORD TO DISCARD KNOWLEDGE OF WHAT HAS GONE BEFORE OR WHAT IS NOW GOING ON IN HIS OWN TRADE AND PROFESSION. IF THE PRINTERS OF TODAY DO NOT WISH TO BE ESTEEMED ARROGANT WHEN THEY TERM THIS CALLING OF THEIRS AN ART, THEY MUST BE WILLING, AND SHOW THAT THEY ARE WILLING, TO SUBJECT IT TO SUCH LAWS AS HAVE MADE ITS SISTER ARTS SO FREE. ALL THOSE CONCERNED IN WHAT ARE ACCEPTED AS THE FINE ARTS, THE LEARNED SCIENCES, AND THE PROFESSIONS SURROUND THEMSELVES WITH THE HISTORY, LITERATURE, AND THE CONCRETE EXAMPLES OF THE WORK WITH WHICH THEY ARE PARTICULARLY ENGAGED. YET IT IS ONLY IN VERY RARE INSTANCES THAT SUCH AN ATMOSPHERE, WITH ITS MATERIAL APPURTENANCES, IS TO BE FOUND IN A PRINTING OFFICE. ART DOES NOT

ABCDEFGHIJKLMN OPQRSTUVWXYZ

\$1234567890

No. 4

THE BEST KIND OF ORIGINALITY IS THAT WHICH COMES AFTER A SOUND APPRENTICESHIP; THAT WHICH SHALL PROVE TO BE THE BLENDING OF A FIRM CONCEPTION OF ALL USEFUL PRECEDENT AND THE PROGRESSIVE TENDENCIES OF AN ABLE MIND. FOR, LET A MAN BE AS ABLE AND ORIGINAL AS HE MAY, HE CANNOT AFFORD TO DISCARD KNOWLEDGE OF WHAT HAS GONE BEFORE OR WHAT IS NOW GOING ON IN HIS OWN TRADE AND PROFESSION. IF THE PRINTERS OF TODAY DO NOT WISH TO BE ESTEEMED ARROGANT WHEN THEY TERM THIS CALLING OF THEIRS AN ART, THEY MUST BE WILLING, AND SHOW THAT THEY ARE WILLING, TO SUBJECT IT TO SUCH LAWS AS HAVE MADE ITS SISTER ARTS SO FREE. ALL THOSE CONCERNED IN WHAT ARE ACCEPTED AS THE FINE ARTS, THE LEARNED SCIENCES, AND THE PROFESSIONS SURROUND THEMSELVES WITH THE HISTORY, LITERATURE, AND THE CONCRETE EXAMPLES OF THE WORK WITH WHICH THEY ARE PARTICULARLY ENGAGED. YET IT IS ONLY IN VERY RARE INSTANCES THAT SUCH AN ATMOSPHERE, WITH ITS MATERIAL APPURTENANCES, IS TO BE FOUND IN A PRINTING OFFICE. ART DOES NOT FLOURISH IN HIDDEN PLACES, NOR UNDER RESTRAINT, NOR IN IGNORANCE OF WHAT TALENT

ABCDEFGHIJKLMN OPQRSTUVWXYZ

\$1234567890

ELECTRO-DISPLAY MATRICES No. 169, shown on page four, are the same type design and are an extension of the 343J Series shown on this page

# No. 343J. Arrangement P-G—Composition Matrices

Specimens of all the possible cap and small cap combinations that can be made with the four sizes in each matrix case

6 Point No. 343J, 5 Set

Nos. 1 and 2

THE BEST KIND OF ORIGINALITY IS THAT WHICH COMES AFTER A SOUND APPRENTICESHIP; THAT WHICH SHALL PROVE TO BE THE BLENDING OF A FIRM CONCEPTION OF ALL USEFUL PRECEDENT AND THE PROGRESSIVE TENDENCIES OF AN ABLE MIND. FOR, LET A MAN BE AS ABLE AND ORIGINAL AS HE MAY, HE CANNOT AFFORD TO DISCARD KNOWLEDGE OF WHAT HAS GONE BEFORE OR WHAT IS NOW GOING ON IN HIS OWN TRADE AND PROFESSION. IF THE PRINTERS OF TODAY DO NOT WISH TO BE ESTEEMED ARROGANT WHEN THEY TERM THIS CALLING OF THEIRS AN ART, THEY MUST BE WILLING, AND SHOW

Nos. 1 and 3

THE BEST KIND OF ORIGINALITY IS THAT WHICH COMES AFTER A SOUND APPRENTICESHIP; THAT WHICH SHALL PROVE TO BE THE BLENDING OF A FIRM CONCEPTION OF ALL USEFUL PRECEDENT AND THE PROGRESSIVE TENDENCIES OF AN ABLE MIND. FOR, LET A MAN BE AS ABLE AND ORIGINAL AS HE MAY, HE CANNOT AFFORD TO DISCARD KNOWLEDGE OF WHAT HAS GONE BEFORE OR WHAT IS NOW GOING ON IN HIS OWN TRADE AND PROFESSION. IF THE PRINTERS OF TODAY DO NOT WISH TO BE ESTEEMED ARROGANT WHEN THEY TERM THIS CALLING OF THEIRS AN ART, THEY MUST BE WILLING, AND SHOW THAT THEY ARE WILLING, TO SUBJECT IT TO SUCH LAWS AS HAVE

Nos. 1 and 4

THE BEST KIND OF ORIGINALITY IS THAT WHICH COMES AFTER A SOUND APPRENTICESHIP; THAT WHICH SHALL PROVE TO BE THE BLENDING OF A FIRM CONCEPTION OF ALL USEFUL PRECEDENT AND THE PROGRESSIVE TENDENCIES OF AN ABLE MIND. FOR, LET A MAN BE AS ABLE AND ORIGINAL AS HE MAY, HE CANNOT AFFORD TO DISCARD KNOWLEDGE OF WHAT HAS GONE BEFORE OR WHAT IS NOW GOING ON IN HIS OWN TRADE AND PROFESSION. IF THE PRINTERS OF TODAY DO NOT WISH TO BE ESTEEMED ARROGANT WHEN THEY TERM THIS CALLING OF THEIRS AN ART, THEY MUST BE WILLING, AND SHOW THAT THEY ARE WILLING, TO SUBJECT IT TO SUCH LAWS AS HAVE MADE ITS SISTER ARTS SO FREE. ALL THOSE CONCERNED IN WHAT ARE ACCEPTED AS

Nos. 2 and 3

THE BEST KIND OF ORIGINALITY IS THAT WHICH COMES AFTER A SOUND APPRENTICESHIP; THAT WHICH SHALL PROVE TO BE THE BLENDING OF A FIRM CONCEPTION OF ALL USEFUL PRECEDENT AND THE PROGRESSIVE TENDENCIES OF AN ABLE MIND. FOR, LET A MAN BE AS ABLE AND ORIGINAL AS HE MAY, HE CANNOT AFFORD TO DISCARD KNOWLEDGE OF WHAT HAS GONE BEFORE OR WHAT IS NOW GOING ON IN HIS OWN TRADE AND PROFESSION. IF THE PRINTERS OF TODAY DO NOT WISH TO BE ESTEEMED ARROGANT WHEN THEY TERM THIS CALLING OF THEIRS AN ART, THEY MUST BE WILLING, AND SHOW THAT THEY ARE WILLING, TO SUBJECT IT TO SUCH LAWS AS

Nos. 2 and 4

THE BEST KIND OF ORIGINALITY IS THAT WHICH COMES AFTER A SOUND APPRENTICESHIP; THAT WHICH SHALL PROVE TO BE THE BLENDING OF A FIRM CONCEPTION OF ALL USEFUL PRECEDENT AND THE PROGRESSIVE TENDENCIES OF AN ABLE MIND. FOR, LET A MAN BE AS ABLE AND ORIGINAL AS HE MAY, HE CANNOT AFFORD TO DISCARD KNOWLEDGE OF WHAT HAS GONE BEFORE OR WHAT IS NOW GOING ON IN HIS OWN TRADE AND PROFESSION. IF THE PRINTERS OF TODAY DO NOT WISH TO BE ESTEEMED ARROGANT WHEN THEY TERM THIS CALLING OF THEIRS AN ART, THEY MUST BE WILLING, AND SHOW THAT THEY ARE WILLING, TO SUBJECT IT TO SUCH LAWS AS HAVE MADE ITS SISTER ARTS SO FREE. ALL THOSE CONCERNED IN WHAT ARE ACCEPTED AS THE FINE ARTS,

Nos. 3 and 4

THE BEST KIND OF ORIGINALITY IS THAT WHICH COMES AFTER A SOUND APPRENTICESHIP; THAT WHICH SHALL PROVE TO BE THE BLENDING OF A FIRM CONCEPTION OF ALL USEFUL PRECEDENT AND THE PROGRESSIVE TENDENCIES OF AN ABLE MIND. FOR, LET A MAN BE AS ABLE AND ORIGINAL AS HE MAY, HE CANNOT AFFORD TO DISCARD KNOWLEDGE OF WHAT HAS GONE BEFORE OR WHAT IS NOW GOING ON IN HIS OWN TRADE AND PROFESSION. IF THE PRINTERS OF TODAY DO NOT WISH TO BE ESTEEMED ARROGANT WHEN THEY TERM THIS CALLING OF THEIRS AN ART, THEY MUST BE WILLING, AND SHOW THAT THEY ARE WILLING, TO SUBJECT IT TO SUCH LAWS AS HAVE MADE ITS SISTER ARTS SO FREE. ALL THOSE CONCERNED IN WHAT ARE ACCEPTED AS THE LEARNED

12 Point No. 343J, 9 Set

Nos. 1 and 2

THE BEST KIND OF ORIGINALITY IS THAT WHICH COMES AFTER A SOUND APPRENTICESHIP; THAT WHICH SHALL PROVE TO BE THE BLENDING OF A FIRM CONCEPTION OF ALL USEFUL PRECEDENT AND THE PROGRESSIVE TENDENCIES OF AN ABLE MIND.

Nos. 1 and 3

THE BEST KIND OF ORIGINALITY IS THAT WHICH COMES AFTER A SOUND APPRENTICESHIP; THAT WHICH SHALL PROVE TO BE THE BLENDING OF A FIRM CONCEPTION OF ALL USEFUL PRECEDENT AND THE PROGRESSIVE TENDENCIES OF AN ABLE MIND. FOR, LET A MAN BE AS ABLE AND

Nos. 1 and 4

THE BEST KIND OF ORIGINALITY IS THAT WHICH COMES AFTER A SOUND APPRENTICESHIP; THAT WHICH SHALL PROVE TO BE THE BLENDING OF A FIRM CONCEPTION OF ALL USEFUL PRECEDENT AND THE PROGRESSIVE TENDENCIES OF AN ABLE MIND. FOR, LET A MAN BE AS ABLE AND ORIGINAL AS HE MAY, HE CANNOT

Nos. 2 and 3

THE BEST KIND OF ORIGINALITY IS THAT WHICH COMES AFTER A SOUND APPRENTICESHIP; THAT WHICH SHALL PROVE TO BE THE BLENDING OF A FIRM CONCEPTION OF ALL USEFUL PRECEDENT AND THE PROGRESSIVE TENDENCIES OF AN ABLE MIND. FOR, LET A MAN BE AS ABLE AND ORIG-

Nos. 2 and 4

THE BEST KIND OF ORIGINALITY IS THAT WHICH COMES AFTER A SOUND APPRENTICESHIP; THAT WHICH SHALL PROVE TO BE THE BLENDING OF A FIRM CONCEPTION OF ALL USEFUL PRECEDENT AND THE PROGRESSIVE TENDENCIES OF AN ABLE MIND. FOR, LET A MAN BE AS ABLE AND ORIGINAL AS HE MAY, HE CANNOT AFFORD TO

Nos. 3 and 4

THE BEST KIND OF ORIGINALITY IS THAT WHICH COMES AFTER A SOUND APPRENTICESHIP; THAT WHICH SHALL PROVE TO BE THE BLENDING OF A FIRM CONCEPTION OF ALL USEFUL PRECEDENT AND THE PROGRESSIVE TENDENCIES OF AN ABLE MIND. FOR, LET A MAN BE AS ABLE AND ORIGINAL AS HE MAY, HE CANNOT AFFORD TO DIS-

ELECTRO-DISPLAY MATRICES No. 169, shown on page four, are the same type design and are an extension of the 343J Series shown on this page

14 Point No. 169

THE FOURTEEN POINT SIZE  
OF THIS SERIES TAKES THE PLACE OF THE CELLULAR, 12H4  
POINT SIZE, WHICH HAS BEEN DISCONTINUED  
\$1234567890

18 Point No. 169

A NON-DISTRIBUTION SYSTEM  
IS POSSIBLE ONLY WITH THE MONOTYPE TYPE AND  
RULE CASTER. SAVES TIME HUNTING SORTS  
\$1234567890

18H4 Point No. 169

OUR TYPE AND RULE CASTER  
TURNS OUT FINISHED RULES, LEADS, SLUGS,  
IN ANY DESIRED LENGTHS  
\$1234567890

24 Point No. 169

NEW AND UP-TO-DATE  
FACES ARE ALWAYS OBTAINABLE ON  
THE MONOTYPE  
\$1234567890

24H4 Point No. 169

PLATE-GOTHICS  
ECONOMICALLY COMPOSED ON  
THE MONOTYPE  
\$1234567890

ELECTRO-DISPLAY MATRICES No. 169, shown on this page, are the same type design and are an extension of the 343J Series shown on pages two and three

# PLATE-GOTHIC No. 344J SERIES

## ARRANGEMENT P-G—COMPOSITION MATRICES

Specimens of the four sizes contained in the matrix case, each size shown separately

Specimens of all the possible cap and small cap combinations that can be made with the four sizes in the matrix case

### 6 Point No. 344J, 8½ Set

### 6 Point No. 344J, 8½ Set

#### No. 1

THE VERY BEST KIND OF ORIGINALITY IS THAT WHICH COMES AFTER A SOUND APPRENTICESHIP; THAT WHICH SHALL PROVE TO BE THE BLENDING OF A FIRM CONCEPTION OF ALL USEFUL PRECEDENT AND THE PROGRESSIVE TENDENCIES OF AN ABLE MIND. FOR, LET A MAN BE AS ABLE AND ORIGINAL AS HE MAY, HE CANNOT AFFORD TO DISCARD KNOWLEDGE OF WHAT HAS GONE BEFORE OR WHAT IS NOW GOING ON IN HIS OWN TRADE AND PROFESSION. IF THE PRINTERS OF TODAY DO NOT WISH TO

ABCDEFGHIJKLMN OPQRSTUVWXYZ  
\$1234567890

#### No. 2

THE VERY BEST KIND OF ORIGINALITY IS THAT WHICH COMES AFTER A SOUND APPRENTICESHIP; THAT WHICH SHALL PROVE TO BE THE BLENDING OF A FIRM CONCEPTION OF ALL USEFUL PRECEDENT AND THE PROGRESSIVE TENDENCIES OF AN ABLE MIND. FOR, LET A MAN BE AS ABLE AND ORIGINAL AS HE MAY, HE CANNOT AFFORD TO DISCARD KNOWLEDGE OF WHAT HAS GONE BEFORE OR WHAT IS NOW GOING ON IN HIS OWN TRADE AND PROFESSION. IF THE PRINTERS OF TODAY DO NOT WISH TO BE ESTEEMED ARROGANT WHEN THEY TERM THIS CALLING OF THEIRS AN ART, THEY MUST

ABCDEFGHIJKLMN OPQRSTUVWXYZ  
\$1234567890

#### No. 3

THE VERY BEST KIND OF ORIGINALITY IS THAT WHICH COMES AFTER A SOUND APPRENTICESHIP; THAT WHICH SHALL PROVE TO BE THE BLENDING OF A FIRM CONCEPTION OF ALL USEFUL PRECEDENT AND THE PROGRESSIVE TENDENCIES OF AN ABLE MIND. FOR, LET A MAN BE AS ABLE AND ORIGINAL AS HE MAY, HE CANNOT AFFORD TO DISCARD A KNOWLEDGE OF WHAT HAS GONE BEFORE OR WHAT IS NOW GOING ON IN HIS OWN TRADE AND PROFESSION. IF THE PRINTERS OF TODAY DO NOT WISH TO BE ESTEEMED ARROGANT WHEN THEY TERM THIS CALLING OF THEIRS AN ART, THEY MUST BE WILLING, AND SHOW THAT THEY ARE WILLING, TO SUBJECT IT TO SUCH

ABCDEFGHIJKLMN OPQRSTUVWXYZ  
\$1234567890

#### No. 4

THE BEST KIND OF ORIGINALITY IS THAT WHICH COMES AFTER A SOUND APPRENTICESHIP; THAT WHICH SHALL PROVE TO BE THE BLENDING OF A FIRM CONCEPTION OF ALL USEFUL PRECEDENT AND OF THE PROGRESSIVE TENDENCIES OF AN ABLE MIND. FOR, LET A MAN BE AS ABLE AND ORIGINAL AS HE MAY, HE CANNOT AFFORD TO DISCARD A KNOWLEDGE OF WHAT HAS GONE BEFORE OR WHAT IS NOW GOING ON IN HIS OWN TRADE AND PROFESSION. IF THE PRINTERS OF TODAY DO NOT WISH TO BE ESTEEMED ARROGANT WHEN THEY TERM THIS CALLING OF THEIRS AN ART, THEY MUST BE WILLING AND SHOW THAT THEY ARE WILLING, TO SUBJECT IT TO SUCH LAWS AS HAVE MADE ITS SISTER ARTS SO FREE. ALL THOSE CONCERNED IN WHAT ARE ACCEPTED AS THE FINE ARTS, THE

ABCDEFGHIJKLMN OPQRSTUVWXYZ  
\$1234567890

#### Nos. 1 and 2

THE VERY BEST KIND OF ORIGINALITY IS THAT WHICH COMES AFTER A SOUND APPRENTICESHIP; THAT WHICH SHALL PROVE TO BE THE BLENDING OF A FIRM CONCEPTION OF ALL USEFUL PRECEDENT AND THE PROGRESSIVE TENDENCIES OF AN ABLE MIND. FOR, LET ANY MAN BE AS ABLE AND ORIGINAL AS HE MAY, HE CANNOT AFFORD TO DISCARD A KNOWLEDGE OF WHAT HAS GONE BEFORE OR WHAT IS NOW GOING ON IN HIS OWN TRADE

#### Nos. 1 and 3

THE BEST KIND OF ORIGINALITY IS THAT WHICH COMES AFTER A SOUND APPRENTICESHIP; THAT WHICH SHALL PROVE TO BE THE BLENDING OF A FIRM CONCEPTION OF ALL USEFUL PRECEDENT AND THE PROGRESSIVE TENDENCIES OF AN ABLE MIND. FOR, LET A MAN BE AS ABLE AND ORIGINAL AS HE MAY, HE CANNOT AFFORD TO DISCARD KNOWLEDGE OF WHAT HAS GONE BEFORE OR WHAT IS NOW GOING ON IN HIS OWN TRADE AND PROFESSION. IF THE PRINTERS OF TODAY DO NOT WISH TO BE

#### Nos. 1 and 4

THE BEST KIND OF ORIGINALITY IS THAT WHICH COMES AFTER A SOUND APPRENTICESHIP; THAT WHICH SHALL PROVE TO BE THE BLENDING OF A FIRM CONCEPTION OF ALL USEFUL PRECEDENT AND THE PROGRESSIVE TENDENCIES OF AN ABLE MIND. FOR, LET A MAN BE AS ABLE AND ORIGINAL AS HE MAY, HE CANNOT AFFORD TO DISCARD KNOWLEDGE OF WHAT HAS GONE BEFORE OR WHAT IS NOW GOING ON IN HIS OWN TRADE AND PROFESSION. IF THE PRINTERS OF TODAY DO NOT WISH TO BE ESTEEMED ARROGANT WHEN THEY TERM THIS CALL-

#### Nos. 2 and 3

THE BEST KIND OF ORIGINALITY IS THAT WHICH COMES AFTER A SOUND APPRENTICESHIP; THAT WHICH SHALL PROVE TO BE THE BLENDING OF A FIRM CONCEPTION OF ALL USEFUL PRECEDENT AND THE PROGRESSIVE TENDENCIES OF AN ABLE MIND. FOR, LET A MAN BE AS ABLE AND ORIGINAL AS HE MAY, HE CANNOT AFFORD TO DISCARD KNOWLEDGE OF WHAT HAS GONE BEFORE OR WHAT IS NOW GOING ON IN HIS OWN TRADE AND PROFESSION. IF THE PRINTERS OF TODAY DO NOT WISH TO BE ESTEEMED

#### Nos. 2 and 4

THE BEST KIND OF ORIGINALITY IS THAT WHICH COMES AFTER A SOUND APPRENTICESHIP; THAT WHICH SHALL PROVE TO BE THE BLENDING OF A FIRM CONCEPTION OF ALL USEFUL PRECEDENT AND THE PROGRESSIVE TENDENCIES OF AN ABLE MIND. FOR, LET A MAN BE AS ABLE AND ORIGINAL AS HE MAY, HE CANNOT AFFORD TO DISCARD KNOWLEDGE OF WHAT HAS GONE BEFORE OR WHAT IS NOW GOING ON IN HIS OWN TRADE AND PROFESSION. IF THE PRINTERS OF TODAY DO NOT WISH TO BE ESTEEMED ARROGANT WHEN THEY TERM THIS CALLING OF THEIRS AN ART

#### Nos. 3 and 4

THE VERY BEST KIND OF ORIGINALITY IS THAT WHICH COMES AFTER A SOUND APPRENTICESHIP; THAT WHICH SHALL PROVE TO BE THE BLENDING OF A FIRM CONCEPTION OF ALL USEFUL PRECEDENT AND THE PROGRESSIVE TENDENCIES OF AN ABLE MIND. FOR, LET A MAN BE AS ABLE AND ORIGINAL AS HE MAY, HE CANNOT AFFORD TO DISCARD KNOWLEDGE OF WHAT HAS GONE BEFORE OR WHAT IS NOW GOING ON IN HIS OWN TRADE AND PROFESSION. IF THE PRINTERS OF TODAY DO NOT WISH TO BE ESTEEMED ARROGANT

THE 344J Series is so arranged that all four sizes of six-point are carried in one Matrix Case. Thus, four sizes may be composed at one operation on the Keyboard, and cast in justified lines on the Casting Machine. At the Keyboard the right and left Keybars and Keybanks P-G and the Stopbars S108 are required, and at the Casting Machine the Normal Wedge S108 is required. A five-unit high space is required before the M and W of the six-point No. 1 size of the 344J series.

When setting by hand, the following plan has been adopted. The six-point is cast to .0697 line. The sizes above six-point are Electro-Display Matrices designated as the No. 166 series and are a continuation of the 344J series, shown on reverse of this sheet. The twelve-point is cast on its standard line .1250; to justify the six- with the twelve-point place four points above and two points below the six-point type. The eight- and the ten-point will be cast on twelve-point body with the standard twelve-point line.

To justify together the twelve-, fourteen-, and eighteen-point sizes, place all the spacing at the top. This makes all sizes line. The comma, semi-colon, and tall of the Cap Q of the eighteen-point size will overhang the body slightly, and there will be a slight overhang at the top of the 18H4 Size.

The line standards for casting type for hand composition for Plate-Gothics according to the above plan will be as follows: Six-point .0697; eight- and ten-point on twelve-point body .1250; twelve-point .1250 (Standard); fourteen-point .1527; eighteen-point .2080.

The Draw Rod should be readjusted to suit the movement of the Centering Pin when running on special line adjustment in order to produce the point line justification.

\*8 Point No. 166

**MONOTYPE FACES**

**THE BEST KIND OF ORIGINALITY IS THAT WHICH COMES AFTER A SOUND APPRENTICESHIP; THAT WHICH SHALL PROVE TO BE THE BLENDING OF A FIRM CONCEPTION OF ALL USEFUL PRECEDENT AND OF THE PROGRESSIVE TENDENCIES OF AN ABLE**

**ABCDEFGHIJKLMNOPQRSTUVWXYZ**

**\$1234567890**

\*10 Point No. 166

**MONOTYPE FACES**

**THE VERY BEST KIND OF ORIGINALITY IS THAT WHICH COMES AFTER A SOUND APPRENTICESHIP; THAT WHICH SHALL PROVE TO BE THE BLENDING OF A FIRM CONCEPTION OF ALL USEFUL PRECEDENT AND THE**

**ABCDEFGHIJKLMNOPQRSTUVWXYZ**

**\$1234567890**

14B Point No. 166

**NEW MONOTYPE TYPE**

**WILL ADD DISTINCTIVENESS TO YOUR NEXT BOOKLET OR CATALOG, ETC.**

**\$1234567890**

14 Point No. 166

**SERVICE AND QUALITY ARE MONOTYPE ASSETS WHICH KEEP YOUR WHOLE PLANT BUSY**

**\$1234567890**

18 Point No. 166

**MORE THAN 1300 FONTS FROM WHICH TO SELECT A FACE TO MEET YOUR NEEDS**

**\$1234567890**

18H4 Point No. 166

**MONOTYPE WORK MEANS MAXIMUM QUALITY AT MINIMUM COST**

**\$1234567890**

\* The 8 and 10 point sizes of this series are cast on the T mold, using the 12 point mold blade.

**ELECTRO-DISPLAY MATRICES No. 166, shown on this page, are the same type design and are an extension of the 344J Series shown on the reverse side of this sheet**

# PLATE-GOTHIC No. 345J SERIES

## COMPOSITION MATRICES

SET YOUR  
ADVERTISEMENTS  
ECONOMICALLY

HAIRDRESSING  
"MARIE"

THE BELVIEU

9 A.M. TO 3 P.M.

FRANK SMITH  
FURNISHINGS

12 N. 52D STREET

ACTO TRUST CO.

SOLICITS  
YOUR  
ACCOUNT

2D AND 4TH AVENUE

MCDONALD'S

FANCY  
GROCERIES  
MEATS

MAIN STREET

PRINT FROM  
NEW TYPE

**T**HE Plate-Gothics are so arranged that all four sizes of six-point are carried in one Matrix Case and, similarly, all four sizes of twelve-point are carried in one Matrix Case. Thus, four sizes may be composed at one operation on the Style D Keyboard, or eight sizes on the Duplex Keyboard, and cast in justified lines on the Casting Machine. At the Keyboard the right and left Keybars and Keybanks P-G and the Stopbars \$108 are required, and at the Casting Machine the Normal Wedge \$108 is required. A five-unit high space is required before the M and W of both six- and twelve-point No. 1 size of the 345J series.

Both six-point and twelve-point fonts will line when cast in composition on the same Mold, but to justify the six-point with the twelve-point, when setting by hand, the following plan has been adopted: The twelve-point remains on its standard line, .1250, but the six-point is cast to .0697 line. The six-point is then justified to the twelve-point by placing four points above and two points below the six-point type. Electro-Display Matrices of the No. 345 series, shown on page four, are the same type design and are an extension of this 345J series and justify with twelve-point by point justification. To justify together the twelve-, fourteen-, eighteen-, and twenty-four-point sizes, place all the spacing at the top. This makes all sizes line. The comma, semi-colon, and tail of the Cap Q of the eighteen- and twenty-four-point sizes will overhang the body slightly, and there will be a slight overhang at the top of the 18H4 and 24H4 sizes.

This plan for point line justifying all sizes of the Plate-Gothic for hand composition applies to all series of Plate-Gothics now ready and those that may be added in the future. The line standards for casting type for hand composition for Plate-Gothics according to the above plan will be as follows:

|                   |                  |
|-------------------|------------------|
| Six-point         | .0697            |
| Twelve-point      | .1250 (Standard) |
| Fourteen-point    | .1527            |
| Eighteen-point    | .2080            |
| Twenty-four-point | .2910            |

The Draw Rod should be readjusted to suit the movement of the Centering Pin when running on special line adjustment in order to produce the point line justification.

SET THEM  
ON THE MONOTYPE  
KEYBOARD

JAMIESON'S  
PHOTO  
SUPPLIES  
SHOP

747 PINE STREET

J. H. GREENE

FOOT FORM SHOES  
FOR  
MEN AND WOMEN

210 EAST STATE STREET

AL. WHITE

HATTER  
SPRING STYLES  
NOW READY

ON THE AVENUE

BRONSON'S

CLOTHES FOR MEN  
CORRECT STYLES

THE BELVIEU

DISCARD  
DISTRIBUTION

**THE DEMAND FOR ALL KINDS OF COMMERCIAL WORK IN THE PLATE-GOTHIC FAMILIES IS CONSTANTLY INCREASING, AND THE PRINTER WITH THESE NEW MONOTYPE COMBINATIONS, ARRANGED TO QUICKEN AND SIMPLIFY EVERY FACTOR OF PRODUCTION, HAS THE ADVANTAGE OF IMPROVING HIS PRESENT QUALITY AT A LOWER COST, AND OF ATTRACTING A BIGGER VOLUME OF NEW BUSINESS TO THE SHOP**

# No. 345J. Arrangement P-G—Composition Matrices

Specimens of the four sizes contained in each matrix case, each size shown separately

12 Point No. 345J, 12 Set

No. 1

**THE BEST KIND OF ORIGINALITY IS THAT WHICH COMES AFTER A SOUND APPRENTICESHIP; THAT WHICH SHALL PROVE TO BE THE BLENDING OF A FIRM CONCEPTION OF ALL USEFUL PRECEDENT AND THE PROGRESSIVE TENDENCY OF**

**ABCDEFGHIJKLMN OPQRSTUVWXYZ**

**\$1234567890**

No. 2

**THE VERY BEST KIND OF ORIGINALITY IS THAT WHICH COMES AFTER A SOUND APPRENTICESHIP; THAT WHICH SHALL PROVE TO BE THE BLENDING OF A FIRM CONCEPTION OF ALL USEFUL PRECEDENT AND THE PROGRESSIVE TENDENCIES OF AN ABLE MIND. FOR, LET A MAN**

**ABCDEFGHIJKLMN OPQRSTUVWXYZ**

**\$1234567890**

No. 3

**THE VERY BEST KIND OF ORIGINALITY IS THAT WHICH COMES AFTER A SOUND APPRENTICESHIP; THAT WHICH SHALL PROVE TO BE THE BLENDING OF A FIRM CONCEPTION OF ALL USEFUL PRECEDENT AND THE PROGRESSIVE TENDENCIES OF AN ABLE MIND. FOR, LET A MAN BE AS ABLE AND ORIGINAL AS HE MAY,**

**ABCDEFGHIJKLMN OPQRSTUVWXYZ**

**\$1234567890**

No. 4

**THE VERY BEST KIND OF ORIGINALITY IS THAT WHICH COMES AFTER A SOUND APPRENTICESHIP; THAT WHICH SHALL PROVE TO BE THE BLENDING OF SOME FIRM CONCEPTION OF ALL USEFUL PRECEDENT AND OF THE PROGRESSIVE TENDENCIES OF AN ABLE MIND. FOR, LET A MAN BE AS ABLE AND ORIGINAL AS HE MAY, HE CANNOT AFFORD TO DISCARD A KNOWLEDGE OF WHAT**

**ABCDEFGHIJKLMN OPQRSTUVWXYZ**

**\$1234567890**

6 Point No. 345J, 7 Set

No. 1

**THE BEST KIND OF ORIGINALITY IS THAT WHICH COMES AFTER A SOUND APPRENTICESHIP; THAT WHICH SHALL PROVE TO BE THE BLENDING OF A FIRM CONCEPTION OF ALL USEFUL PRECEDENT AND THE PROGRESSIVE TENDENCIES OF AN ABLE MIND. FOR, LET A MAN BE AS ABLE AND ORIGINAL AS HE MAY, HE CANNOT AFFORD TO DISCARD KNOWLEDGE OF WHAT HAS GONE BEFORE OR WHAT IS NOW GOING ON IN HIS OWN TRADE AND PROFESSION. IF THE PRINTERS OF TODAY DO NOT WISH TO BE ESTEEMED ARROGANT WHEN THEY TERM THIS CALLING OF THEIRS AN ART, THEY MUST BE**

**ABCDEFGHIJKLMN OPQRSTUVWXYZ**

**\$1234567890**

No. 2

**THE BEST KIND OF ORIGINALITY IS THAT WHICH COMES AFTER A SOUND APPRENTICESHIP; THAT WHICH SHALL PROVE TO BE THE BLENDING OF A FIRM CONCEPTION OF ALL USEFUL PRECEDENT AND THE PROGRESSIVE TENDENCIES OF AN ABLE MIND. FOR, LET A MAN BE AS ABLE AND ORIGINAL AS HE MAY, HE CANNOT AFFORD TO DISCARD KNOWLEDGE OF WHAT HAS GONE BEFORE OR WHAT IS NOW GOING ON IN HIS OWN TRADE AND HIS PROFESSION. IF THE PRINTERS OF TODAY DO NOT WISH TO BE ESTEEMED ARROGANT WHEN THEY TERM THIS CALLING OF THEIRS AN ART, THEY MUST BE WILLING, AND SHOW THAT THEY ARE WILLING, TO SUBJECT IT TO SUCH LAWS**

**ABCDEFGHIJKLMN OPQRSTUVWXYZ**

**\$1234567890**

No. 3

**THE BEST KIND OF ORIGINALITY IS THAT WHICH COMES AFTER A SOUND APPRENTICESHIP; THAT WHICH SHALL PROVE TO BE THE BLENDING OF A FIRM CONCEPTION OF ALL USEFUL PRECEDENT AND THE PROGRESSIVE TENDENCIES OF AN ABLE MIND. FOR, LET A MAN BE AS ABLE AND ORIGINAL AS HE MAY, HE CANNOT AFFORD TO DISCARD A KNOWLEDGE OF WHAT HAS GONE BEFORE OR WHAT IS NOW GOING ON IN HIS OWN TRADE AND PROFESSION. IF THE PRINTERS OF TODAY DO NOT WISH TO BE ESTEEMED ARROGANT WHEN THEY TERM THIS CALLING OF THEIRS AN ART, THEY MUST BE WILLING, AND SHOW THAT THEY ARE WILLING, TO SUBJECT IT TO SUCH LAWS AS HAVE MADE ITS SISTER ARTS SO FREE. ALL THOSE CONCERNED IN WHAT ARE ACCEPTED AS THE FINE ARTS, THE LEARNED**

**ABCDEFGHIJKLMN OPQRSTUVWXYZ**

**\$1234567890**

No. 4

**THE BEST KIND OF ORIGINALITY IS THAT WHICH COMES AFTER A SOUND APPRENTICESHIP; THAT WHICH SHALL PROVE TO BE THE BLENDING OF A FIRM CONCEPTION OF ALL USEFUL PRECEDENT AND THE PROGRESSIVE TENDENCIES OF AN ABLE MIND. FOR, LET A MAN BE AS ABLE AND ORIGINAL AS HE MAY, HE CANNOT AFFORD TO DISCARD A KNOWLEDGE OF WHAT HAS GONE BEFORE OR WHAT IS NOW GOING ON IN HIS OWN TRADE AND PROFESSION. IF THE PRINTERS OF TODAY DO NOT WISH TO BE ESTEEMED ARROGANT WHEN THEY TERM THIS CALLING OF THEIRS AN ART, THEY MUST BE WILLING, AND SHOW THAT THEY ARE WILLING, TO SUBJECT IT TO SUCH LAWS AS HAVE MADE ITS SISTER ARTS SO FREE. ALL THOSE CONCERNED IN WHAT ARE ACCEPTED AS THE FINE ARTS, THE LEARNED SCIENCES, AND PROFESSIONS SURROUNDED THEMSELVES WITH**

**ABCDEFGHIJKLMN OPQRSTUVWXYZ**

**\$1234567890**

ELECTRO-DISPLAY MATRICES No. 345, shown on page four, are the same type design and are an extension of the 345J Series shown on this page

# No. 345J. Arrangement P-G—Composition Matrices

Specimens of all the possible cap and small cap combinations that can be made with the four sizes in each matrix case

6 Point No. 345J, 7 Set

Nos. 1 and 2

THE BEST KIND OF ORIGINALITY IS THAT WHICH COMES AFTER A SOUND APPRENTICESHIP; THAT WHICH SHALL PROVE TO BE THE BLENDING OF A FIRM CONCEPTION OF ALL USEFUL PRECEDENT AND THE PROGRESSIVE TENDENCIES OF AN ABLE MIND. FOR, LET A MAN BE AS ABLE AND ORIGINAL AS HE MAY, HE CANNOT AFFORD TO DISCARD A KNOWLEDGE OF WHAT HAS GONE BEFORE OR WHAT IS NOW GOING ON IN HIS

Nos. 1 and 3

THE BEST KIND OF ORIGINALITY IS THAT WHICH COMES AFTER A SOUND APPRENTICESHIP; THAT WHICH SHALL PROVE TO BE THE BLENDING OF A FIRM CONCEPTION OF ALL USEFUL PRECEDENT AND THE PROGRESSIVE TENDENCIES OF AN ABLE MIND. FOR, LET A MAN BE AS ABLE AND ORIGINAL AS HE MAY, HE CANNOT AFFORD TO DISCARD A KNOWLEDGE OF WHAT HAS GONE BEFORE OR WHAT IS NOW GOING ON IN HIS OWN TRADE AND PROFESSION. IF THE PRINTERS OF TODAY DO NOT

Nos. 1 and 4

THE BEST KIND OF ORIGINALITY IS THAT WHICH COMES AFTER A SOUND APPRENTICESHIP; THAT WHICH SHALL PROVE TO BE THE BLENDING OF A FIRM CONCEPTION OF ALL USEFUL PRECEDENT AND THE PROGRESSIVE TENDENCIES OF AN ABLE MIND. FOR, LET A MAN BE AS ABLE AND ORIGINAL AS HE MAY, HE CANNOT AFFORD TO DISCARD A KNOWLEDGE OF WHAT HAS GONE BEFORE OR WHAT IS NOW GOING ON IN HIS OWN TRADE AND HIS PROFESSION. IF THE PRINTERS OF TODAY DO NOT WISH TO BE ESTEEMED ARROGANT WHEN THEY TERM

Nos. 2 and 3

THE BEST KIND OF ORIGINALITY IS THAT WHICH COMES AFTER A SOUND APPRENTICESHIP; THAT WHICH SHALL PROVE TO BE THE BLENDING OF A FIRM CONCEPTION OF ALL USEFUL PRECEDENT AND THE PROGRESSIVE TENDENCIES OF AN ABLE MIND. FOR, LET A MAN BE AS ABLE AND ORIGINAL AS HE MAY, HE CANNOT AFFORD TO DISCARD A KNOWLEDGE OF WHAT HAS GONE BEFORE OR WHAT IS NOW GOING ON IN HIS OWN TRADE AND PROFESSION. IF THE PRINTERS OF TODAY DO NOT

Nos. 2 and 4

THE BEST KIND OF ORIGINALITY IS THAT WHICH COMES AFTER A SOUND APPRENTICESHIP; THAT WHICH SHALL PROVE TO BE THE BLENDING OF A FIRM CONCEPTION OF ALL USEFUL PRECEDENT AND THE PROGRESSIVE TENDENCIES OF AN ABLE MIND. FOR, LET A MAN BE AS ABLE AND ORIGINAL AS HE MAY, HE CANNOT AFFORD TO DISCARD A KNOWLEDGE OF WHAT HAS GONE BEFORE OR WHAT IS NOW GOING ON IN HIS OWN TRADE AND PROFESSION. IF THE PRINTERS OF TODAY DO NOT WISH TO BE ESTEEMED ARROGANT WHEN THEY TERM THIS CALLING OF

Nos. 3 and 4

THE BEST KIND OF ORIGINALITY IS THAT WHICH COMES AFTER A SOUND APPRENTICESHIP; THAT WHICH SHALL PROVE TO BE THE BLENDING OF A FIRM CONCEPTION OF ALL USEFUL PRECEDENT AND THE PROGRESSIVE TENDENCIES OF AN ABLE MIND. FOR, LET A MAN BE AS ABLE AND ORIGINAL AS HE MAY, HE CANNOT AFFORD TO DISCARD A KNOWLEDGE OF WHAT HAS GONE BEFORE OR WHAT IS NOW GOING ON IN HIS OWN TRADE AND PROFESSION. IF THE PRINTERS OF TODAY DO NOT WISH TO BE ESTEEMED ARROGANT WHEN THEY TERM THIS CALLING OF

12 Point No. 345J, 12 Set

Nos. 1 and 2

THE BEST KIND OF ORIGINALITY IS THAT WHICH COMES AFTER A SOUND APPRENTICESHIP; THAT WHICH SHALL PROVE TO BE THE BLENDING OF A FIRM CONCEPTION OF ALL USEFUL PRECE-

Nos. 1 and 3

THE BEST KIND OF ORIGINALITY IS THAT WHICH COMES AFTER A SOUND APPRENTICESHIP; THAT WHICH SHALL PROVE TO BE THE BLENDING OF A FIRM CONCEPTION OF ALL USEFUL PRECEDENT AND THE PROGRES-

Nos. 1 and 4

THE BEST KIND OF ORIGINALITY IS THAT WHICH COMES AFTER A SOUND APPRENTICESHIP; THAT WHICH SHALL PROVE TO BE THE BLENDING OF A FIRM CONCEPTION OF ALL USEFUL PRECEDENT AND THE PROGRESSIVE TENDENCIES OF AN ABLE MIND.

Nos. 2 and 3

THE BEST KIND OF ORIGINALITY IS THAT WHICH COMES AFTER A SOUND APPRENTICESHIP; THAT WHICH SHALL PROVE TO BE THE BLENDING OF A FIRM CONCEPTION OF ALL USEFUL PRECEDENT AND THE PROGRESSIVE

Nos. 2 and 4

THE BEST KIND OF ORIGINALITY IS THAT WHICH COMES AFTER A SOUND APPRENTICESHIP; THAT WHICH SHALL PROVE TO BE THE BLENDING OF A FIRM CONCEPTION OF ALL USEFUL PRECEDENT AND THE PROGRESSIVE TENDENCIES OF AN ABLE MIND.

Nos. 3 and 4

THE VERY BEST KIND OF ORIGINALITY IS THAT WHICH COMES AFTER A SOUND APPRENTICESHIP; THAT WHICH SHALL PROVE TO BE THE BLENDING OF A FIRM CONCEPTION OF ALL USEFUL PRECEDENT AND THE PROGRESSIVE TENDENCIES OF AN ABLE MIND.



The 14, 18, 18H4, 24 and 24H4 sizes of No. 345 series  
are in preparation

ELECTRO-DISPLAY MATRICES No. 345, in preparation, are the same type design and are an extension of the  
345J Series shown on pages two and three

# PLATE-GOTHIC No. 346K SERIES

## COMPOSITION MATRICES

**T**HE Plate-Gothics are so arranged that all four sizes of six-point are carried in one Matrix Case and, similarly, all four sizes of twelve-point are carried in one Matrix Case. Thus, four sizes may be composed at one operation on the Style D Keyboard, or eight sizes on the Duplex Keyboard, and cast in justified lines on the Casting Machine. At the Keyboard the right and left Keybars and Keybanks PG and the Stopbars S108 are required, and at the Casting Machine the Normal Wedge S108 is required. A five-unit high space is required before the M and W of both six- and twelve-point No. 1 size of the 346K series.

Both six-point and twelve-point fonts will line when cast in composition on the same Mold, but to justify the six-point with the twelve-point, when setting by hand, the following plan has been adopted: The twelve-point remains on its standard line, .1250, but the six-point is cast to .0697 line. The six-point is then justified to the twelve-point by placing four points above and two points below the six-point type. Electro-Display Matrices of the No. 3461 series, shown on page four, are the same type design and are an extension of this 346K series and

justify with twelve-point by point justification. To justify together the twelve-, fourteen-, eighteen-, and twenty-four-point sizes, place all the spacing at the top. This makes all sizes line. The comma, semi-colon, and tail of the Cap Q of the eighteen- and twenty-four-point sizes will overhang the body slightly, and there will be a slight overhang at the top of the 18H4 and 24H4 sizes.

This plan for point line justifying all sizes of the Plate-Gothic for hand composition applies to all series of Plate-Gothics now ready and those that may be added in the future. The line standards for casting type for hand composition for Plate-Gothics according to the above plan will be as follows:

|                   |                  |
|-------------------|------------------|
| Six-point         | .0697            |
| Twelve-point      | .1250 (Standard) |
| Fourteen-point    | .1527            |
| Eighteen-point    | .2080            |
| Twenty-four-point | .2910            |

The Draw Rod should be readjusted to suit the movement of the Centering Pin when running on special line adjustment in order to produce the point line justification.

## EXPERIENCE AND PERFECTION

**ANY MACHINE WHICH SUPPLANTS HAND LABOR MUST GO THROUGH A PERIOD OF SUSPICION. PERFECTION OF A MACHINE CAN COME ONLY THROUGH THE EXPERIENCE OF THE PERSON USING IT. EXPERIENCE IS OUR GREATEST SALESMAN. MORE THAN ONE-HALF OF OUR ORDERS TO-DAY ARE FROM PRINTERS WHO KNOW FROM EXPERIENCE THAT THE MONOTYPE MEANS PERFECTION IN THE COMPOSING ROOM.**

**LANSTON MONOTYPE MACHINE CO.**

**PHILADELPHIA**

# No. 346K. Arrangement P-G—Composition Matrices

Specimens of the four sizes contained in each matrix case, each size shown separately

12 Point No. 346K, 12 Set

6 Point No. 346K, 7 Set

No. 1

**THE BEST KIND OF ORIGINALITY IS THAT WHICH COMES AFTER A SOUND APPRENTICESHIP; THAT WHICH SHALL PROVE TO BE THE BLENDING OF A FIRM CONCEPTION OF ALL USEFUL PRECEDENT AND THE PROGRESSIVE TENDEN-**

**ABCDEFGHIJKLMNOPQRSTUVWXYZ**

**\$1234567890**

No. 2

**THE BEST KIND OF ORIGINALITY IS THAT WHICH COMES AFTER A SOUND APPRENTICESHIP; THAT WHICH SHALL PROVE TO BE THE BLENDING OF A FIRM CONCEPTION OF ALL USEFUL PRECEDENT AND THE PROGRESSIVE TENDENCIES OF AN ABLE MIND. FOR, LET A MAN**

**ABCDEFGHIJKLMNOPQRSTUVWXYZ**

**\$1234567890**

No. 3

**THE VERY BEST KIND OF ORIGINALITY IS THAT WHICH COMES AFTER A SOUND APPRENTICESHIP; THAT WHICH SHALL PROVE TO BE THE BLENDING OF A FIRM CONCEPTION OF ALL USEFUL PRECEDENT AND THE PROGRESSIVE TENDENCIES OF AN ABLE MIND. FOR, LET A MAN BE AS ABLE AND ORIGINAL AS HE MAY,**

**ABCDEFGHIJKLMNOPQRSTUVWXYZ**

**\$1234567890**

No. 4

**THE BEST KIND OF ORIGINALITY IS THAT WHICH COMES AFTER A SOUND APPRENTICESHIP; THAT WHICH SHALL PROVE TO BE THE BLENDING OF A FIRM CONCEPTION OF ALL USEFUL PRECEDENT AND THE PROGRESSIVE TENDENCIES OF AN ABLE MIND. FOR, LET A MAN BE AS ABLE AND ORIGINAL AS HE MAY, HE CANNOT AFFORD TO DISCARD A KNOWLEDGE OF WHAT HAS**

**ABCDEFGHIJKLMNOPQRSTUVWXYZ**

**\$1234567890**

No. 1

**THE BEST KIND OF ORIGINALITY IS THAT WHICH COMES AFTER A SOUND APPRENTICESHIP; THAT WHICH SHALL PROVE TO BE THE BLENDING OF A FIRM CONCEPTION OF ALL USEFUL PRECEDENT AND THE PROGRESSIVE TENDENCIES OF AN ABLE MIND. FOR, LET A MAN BE AS ABLE AND ORIGINAL AS HE MAY, HE CANNOT AFFORD TO DISCARD KNOWLEDGE OF WHAT HAS GONE BEFORE OR WHAT IS NOW GOING ON IN HIS OWN TRADE AND PROFESSION. IF THE PRINTERS OF TODAY DO NOT WISH TO BE ESTEEMED ARROGANT WHEN THEY TERM THIS CALLING OF THEIRS AN ART, THEY MUST BE**

**ABCDEFGHIJKLMNOPQRSTUVWXYZ**

**\$1234567890**

No. 2

**THE BEST KIND OF ORIGINALITY IS THAT WHICH COMES AFTER A SOUND APPRENTICESHIP; THAT WHICH SHALL PROVE TO BE THE BLENDING OF A FIRM CONCEPTION OF ALL USEFUL PRECEDENT AND THE PROGRESSIVE TENDENCIES OF AN ABLE MIND. FOR, LET A MAN BE AS ABLE AND ORIGINAL AS HE MAY, HE CANNOT AFFORD TO DISCARD KNOWLEDGE OF WHAT HAS GONE BEFORE OR WHAT IS NOW GOING ON IN HIS OWN TRADE AND PROFESSION. IF THE PRINTERS OF TODAY DO NOT WISH TO BE ESTEEMED ARROGANT WHEN THEY TERM THIS CALLING OF THEIRS AN ART, THEY MUST BE WILLING, AND SHOW THAT THEY ARE WILLING, TO SUBJECT IT TO SUCH LAWS**

**ABCDEFGHIJKLMNOPQRSTUVWXYZ**

**\$1234567890**

No. 3

**THE BEST KIND OF ORIGINALITY IS THAT WHICH COMES AFTER A SOUND APPRENTICESHIP; THAT WHICH SHALL PROVE TO BE THE BLENDING OF A FIRM CONCEPTION OF ALL USEFUL PRECEDENT AND THE PROGRESSIVE TENDENCIES OF AN ABLE MIND. FOR, LET A MAN BE AS ABLE AND ORIGINAL AS HE MAY, HE CANNOT AFFORD TO DISCARD A KNOWLEDGE OF WHAT HAS GONE BEFORE OR WHAT IS NOW GOING ON IN HIS OWN TRADE AND PROFESSION. IF THE PRINTERS OF TODAY DO NOT WISH TO BE ESTEEMED ARROGANT WHEN THEY TERM THIS CALLING OF THEIRS AN ART, THEY MUST BE WILLING, AND SHOW THAT THEY ARE WILLING, TO SUBJECT IT TO SUCH LAWS AS HAVE MADE ITS SISTER ARTS SO FREE. ALL THOSE CONCERNED IN WHAT ARE ACCEPTED AS THE FINE ARTS, THE LEARNED**

**ABCDEFGHIJKLMNOPQRSTUVWXYZ**

**\$1234567890**

No. 4

**THE BEST KIND OF ORIGINALITY IS THAT WHICH COMES AFTER A SOUND APPRENTICESHIP; THAT WHICH SHALL PROVE TO BE THE BLENDING OF A FIRM CONCEPTION OF ALL USEFUL PRECEDENT AND THE PROGRESSIVE TENDENCIES OF AN ABLE MIND. FOR, LET A MAN BE AS ABLE AND ORIGINAL AS HE MAY, HE CANNOT AFFORD TO DISCARD A KNOWLEDGE OF WHAT HAS GONE BEFORE OR WHAT IS NOW GOING ON IN HIS OWN TRADE AND PROFESSION. IF THE PRINTERS OF TODAY DO NOT WISH TO BE ESTEEMED ARROGANT WHEN THEY TERM THIS CALLING OF THEIRS AN ART, THEY MUST BE WILLING, AND SHOW THAT THEY ARE WILLING, TO SUBJECT IT TO SUCH LAWS AS HAVE MADE ITS SISTER ARTS SO FREE. ALL THOSE CONCERNED IN WHAT ARE ACCEPTED AS THE FINE ARTS, THE LEARNED SCIENCES, AND PROFESSIONS SURROUND THEMSELVES WITH**

**ABCDEFGHIJKLMNOPQRSTUVWXYZ**

**\$1234567890**

ELECTRO-DISPLAY MATRICES No. 346, shown on page four, are the same type design and are an extension of the 346K Series shown on this page

# No. 346K. Arrangement P-G—Composition Matrices

Specimens of all the possible cap and small cap combinations that can be made with the four sizes in each matrix case

6 Point No. 346K, 7 Set

Nos. 1 and 2

**THE BEST KIND OF ORIGINALITY IS THAT WHICH COMES AFTER A SOUND APPRENTICESHIP; THAT WHICH SHALL PROVE TO BE THE BLENDING OF A FIRM CONCEPTION OF ALL USEFUL PRECEDENT AND THE PROGRESSIVE TENDENCIES OF AN ABLE MIND. FOR, LET A MAN BE AS ABLE AND ORIGINAL AS HE MAY, HE CANNOT AFFORD TO DISCARD KNOWLEDGE OF WHAT HAS GONE BEFORE OR WHAT IS NOW GOING ON IN HIS**

Nos. 1 and 3

**THE BEST KIND OF ORIGINALITY IS THAT WHICH COMES AFTER A SOUND APPRENTICESHIP; THAT WHICH SHALL PROVE TO BE THE BLENDING OF A FIRM CONCEPTION OF ALL USEFUL PRECEDENT AND THE PROGRESSIVE TENDENCIES OF AN ABLE MIND. FOR, LET A MAN BE AS ABLE AND ORIGINAL AS HE MAY, HE CANNOT AFFORD TO DISCARD A KNOWLEDGE OF WHAT HAS GONE BEFORE OR WHAT IS NOW GOING ON IN HIS OWN TRADE AND PROFESSION. IF THE PRINTERS OF TODAY DO NOT**

Nos. 1 and 4

**THE BEST KIND OF ORIGINALITY IS THAT WHICH COMES AFTER A SOUND APPRENTICESHIP; THAT WHICH SHALL PROVE TO BE THE BLENDING OF A FIRM CONCEPTION OF ALL USEFUL PRECEDENT AND THE PROGRESSIVE TENDENCIES OF AN ABLE MIND. FOR, LET A MAN BE AS ABLE AND ORIGINAL AS HE MAY, HE CANNOT AFFORD TO DISCARD KNOWLEDGE OF WHAT HAS GONE BEFORE OR WHAT IS NOW GOING ON IN HIS OWN TRADE AND PROFESSION. IF THE PRINTERS OF TODAY DO NOT WISH TO BE ESTEEMED ARROGANT WHEN THEY TERM**

Nos. 2 and 3

**THE BEST KIND OF ORIGINALITY IS THAT WHICH COMES AFTER A SOUND APPRENTICESHIP; THAT WHICH SHALL PROVE TO BE THE BLENDING OF A FIRM CONCEPTION OF ALL USEFUL PRECEDENT AND THE PROGRESSIVE TENDENCIES OF AN ABLE MIND. FOR, LET A MAN BE AS ABLE AND ORIGINAL AS HE MAY, HE CANNOT AFFORD TO DISCARD A KNOWLEDGE OF WHAT HAS GONE BEFORE OR WHAT IS NOW GOING ON IN HIS OWN TRADE AND PROFESSION. IF THE PRINTERS OF TODAY DO NOT**

Nos. 2 and 4

**THE BEST KIND OF ORIGINALITY IS THAT WHICH COMES AFTER A SOUND APPRENTICESHIP; THAT WHICH SHALL PROVE TO BE THE BLENDING OF A FIRM CONCEPTION OF ALL USEFUL PRECEDENT AND THE PROGRESSIVE TENDENCIES OF AN ABLE MIND. FOR, LET A MAN BE AS ABLE AND ORIGINAL AS HE MAY, HE CANNOT AFFORD TO DISCARD A KNOWLEDGE OF WHAT HAS GONE BEFORE OR WHAT IS NOW GOING ON IN HIS OWN TRADE AND PROFESSION. IF THE PRINTERS OF TODAY DO NOT WISH TO BE ESTEEMED ARROGANT WHEN THEY TERM THIS**

Nos. 3 and 4

**THE BEST KIND OF ORIGINALITY IS THAT WHICH COMES AFTER A SOUND APPRENTICESHIP; THAT WHICH SHALL PROVE TO BE THE BLENDING OF A FIRM CONCEPTION OF ALL USEFUL PRECEDENT AND THE PROGRESSIVE TENDENCIES OF AN ABLE MIND. FOR, LET A MAN BE AS ABLE AND ORIGINAL AS HE MAY, HE CANNOT AFFORD TO DISCARD A KNOWLEDGE OF WHAT HAS GONE BEFORE OR WHAT IS NOW GOING ON IN HIS OWN TRADE AND PROFESSION. IF THE PRINTERS OF TODAY DO NOT WISH TO BE ESTEEMED ARROGANT WHEN THEY TERM THIS CALLING OF**

12 Point No. 346K, 12 Set

Nos. 1 and 2

**THE BEST KIND OF ORIGINALITY IS THAT WHICH COMES AFTER A SOUND APPRENTICESHIP; THAT WHICH SHALL PROVE TO BE THE BLENDING OF A FIRM CONCEPTION OF ALL USEFUL PRECE-**

Nos. 1 and 3

**THE BEST KIND OF ORIGINALITY IS THAT WHICH COMES AFTER A SOUND APPRENTICESHIP; THAT WHICH SHALL PROVE TO BE THE BLENDING OF A FIRM CONCEPTION OF ALL USEFUL PRECEDENT AND THE PROGRESS-**

Nos. 1 and 4

**THE BEST KIND OF ORIGINALITY IS THAT WHICH COMES AFTER A SOUND APPRENTICESHIP; THAT WHICH SHALL PROVE TO BE THE BLENDING OF A FIRM CONCEPTION OF ALL USEFUL PRECEDENT AND THE PROGRESSIVE TENDENCIES OF AN ABLE**

Nos. 2 and 3

**THE BEST KIND OF ORIGINALITY IS THAT WHICH COMES AFTER A SOUND APPRENTICESHIP; THAT WHICH SHALL PROVE TO BE THE BLENDING OF A FIRM CONCEPTION OF ALL USEFUL PRECEDENT AND THE PROGRESS-**

Nos. 2 and 4

**THE BEST KIND OF ORIGINALITY IS THAT WHICH COMES AFTER A SOUND APPRENTICESHIP; THAT WHICH SHALL PROVE TO BE THE BLENDING OF A FIRM CONCEPTION OF ALL USEFUL PRECEDENT AND THE PROGRESSIVE TENDENCIES OF AN ABLE MIND.**

Nos. 3 and 4

**THE BEST KIND OF ORIGINALITY IS THAT WHICH COMES AFTER A SOUND APPRENTICESHIP; THAT WHICH SHALL PROVE TO BE THE BLENDING OF A FIRM CONCEPTION OF ALL USEFUL PRECEDENT AND THE PROGRESSIVE TENDENCIES OF AN ABLE MIND.**

ELECTRO-DISPLAY MATRICES No. 3461, shown on page four, are the same type design and are an extension of the 346K Series shown on this page

The 14, 18, 18H4, 24 and 24H4 sizes of No. 3461 series are in preparation

ELECTRO-DISPLAY MATRICES No. 3461, in preparation, are the same type design and are an extension of the 346K series shown on pages two and three

# TITLE [PLATE-GOTHIC] No. 347J SERIES

## ARRANGEMENT P-G—COMPOSITION MATRICES

Specimens of the four sizes contained in the matrix case, each size shown separately

6 Point No. 347J, 8 Set

No. 1

THE VERY BEST KIND OF ORIGINALITY IS THAT WHICH COMES AFTER A THOROUGH APPRENTICESHIP; IT IS THAT WHICH SHALL PROVE TO BE THE BLENDING OF A FIRM CONCEPTION OF ALL USEFUL PRECEDENT AND THE PROGRESSIVE TENDENCIES OF AN ABLE MIND. FOR, LET A MAN BE AS ABLE AND ORIGINAL AS HE MAY, HE CANNOT AFFORD TO DISCARD KNOWLEDGE OF WHAT HAS GONE BEFORE OR WHAT IS NOW GOING ON IN HIS OWN TRADE AND PROFESSION. IF THE PRINTERS OF TODAY DO NOT WISH TO BE ESTERMED ARROGANT WHEN THEY

ABCDEFGHIJKLMNQPQRSTUWXYZ  
\$1234567890

No. 2

THE VERY BEST KIND OF ORIGINALITY IS THAT WHICH COMES AFTER A THOROUGH APPRENTICESHIP; THAT WHICH SHALL PROVE TO BE THE BLENDING OF A FIRM CONCEPTION OF ALL USEFUL PRECEDENT AND THE PROGRESSIVE TENDENCIES OF AN ABLE MIND. FOR, LET A MAN BE AS ABLE AND ORIGINAL AS HE MAY, HE CANNOT AFFORD TO DISCARD KNOWLEDGE OF WHAT HAS GONE BEFORE OR WHAT IS NOW GOING ON IN HIS OWN TRADE AND PROFESSION. IF THE PRINTERS OF TODAY DO NOT WISH TO BE ESTERMED ARROGANT WHEN THEY TERM THIS CALLING OF THEIRS AN ART, THEY MUST BE WILLING, AND

ABCDEFGHIJKLMNQPQRSTUWXYZ  
\$1234567890

No. 3

THE VERY BEST KIND OF ORIGINALITY IS THAT WHICH COMES AFTER A SOUND APPRENTICESHIP; THAT WHICH SHALL PROVE TO BE THE BLENDING OF A FIRM CONCEPTION OF ALL USEFUL PRECEDENT AND THE PROGRESSIVE TENDENCIES OF AN ABLE MIND. FOR, LET A MAN BE AS ABLE AND ORIGINAL AS HE MAY, HE CANNOT AFFORD TO DISCARD A KNOWLEDGE OF WHAT HAS GONE BEFORE OR WHAT IS NOW GOING ON IN HIS OWN TRADE AND PROFESSION. IF THE PRINTERS OF TODAY DO NOT WISH TO BE ESTERMED ARROGANT WHEN THEY TERM THIS CALLING OF THEIRS AN ART, THEY MUST BE WILLING, AND SHOW THAT THEY ARE WILLING TO SUBJECT IT TO SUCH LAWS AS HAVE MADE ITS SISTER ARTS SO FREE.

ABCDEFGHIJKLMNQPQRSTUWXYZ  
\$1234567890

No. 4

THE BEST KIND OF ORIGINALITY IS THAT WHICH COMES AFTER A SOUND APPRENTICESHIP; THAT WHICH SHALL PROVE TO BE THE BLENDING OF A FIRM CONCEPTION OF ALL USEFUL PRECEDENT AND OF THE PROGRESSIVE TENDENCIES OF AN ABLE MIND. FOR, LET A MAN BE AS ABLE AND ORIGINAL AS HE MAY, HE CANNOT AFFORD TO DISCARD A KNOWLEDGE OF WHAT HAS GONE BEFORE OR WHAT IS NOW GOING ON IN HIS OWN TRADE AND PROFESSION. IF THE PRINTERS OF TODAY DO NOT WISH TO BE ESTERMED ARROGANT WHEN THEY TERM THIS CALLING OF THEIRS AN ART, THEY MUST BE WILLING, AND SHOW THAT THEY ARE WILLING, TO SUBJECT IT TO SUCH LAWS AS HAVE MADE ITS SISTER ARTS SO FREE. ALL THOSE CONCERNED IN WHAT ARE ACCREDITED AS THE FINE ARTS, THE LEARNED SCIENCES, AND THE PROFESSIONS SURROUNDING THEM,

ABCDEFGHIJKLMNQPQRSTUWXYZ  
\$1234567890

THE 347J Series is so arranged that all four sizes of six-point are carried in one Matrix Case. Thus, four sizes may be composed at one operation on the Keyboard, and cast in justified lines on the Casting Machine. At the Keyboard the right and left Keybars and Keybanks P-G and the Stopbars S108 are required, and at the Casting Machine the Normal Wedge S108 is required. A five-unit high space is required before the M and W of the six-point No. 1 size of the 347J Series.

When setting by hand, the following plan has been adopted. The six-point is cast to .0697 line. The sizes above six-point are Electro-Display Matrices designated as the No. 223 Series and are a continuation of the 347J Series, shown on reverse of this sheet. The twelve-point is cast on its standard line .1250; to justify the six- with the twelve-point place four points above and two points below the six-point type. The eight- and ten-point will be cast on twelve-point body with the standard twelve-point line.

To justify together the twelve-, eighteen-, and twenty-four-point sizes, place all the spacing at the top. This makes all sizes line. The comma, semicolon, and tail of the Cap Q of the eighteen- and twenty-four-point size will overhang the body slightly.

The line standards for casting type for hand composition for Plate-Gothics according to the above plan will be as follows: Six-point .0697; eight- and ten-point on twelve-point body .1250; twelve-point .1250 (Standard); eighteen-point .2090; twenty-four-point .3910.

The Draw Rod should be readjusted to suit the movement of the Centering Pin when running on special line adjustment in order to produce the point line justification.

Specimens of all the possible cap and small cap combinations that can be made with the four sizes in the matrix case

6 Point No. 347J, 8 Set

Nos. 1 and 2

THE VERY BEST KIND OF ORIGINALITY IS THAT WHICH COMES AFTER A SOUND APPRENTICESHIP; THAT WHICH SHALL PROVE TO BE THE BLENDING OF A FIRM CONCEPTION OF ALL USEFUL PRECEDENT AND THE PROGRESSIVE TENDENCIES OF AN ABLE MIND. FOR, LET ANY MAN BE AS ABLE AND ORIGINAL AS HE MAY, HE CANNOT AFFORD TO DISCARD A KNOWLEDGE OF WHAT HAS GONE BEFORE OR WHAT IS NOW GOING ON IN HIS OWN TRADE AND PROFESSION.

Nos. 1 and 3

THE BEST KIND OF ORIGINALITY IS THAT WHICH COMES AFTER A SOUND APPRENTICESHIP; THAT WHICH SHALL PROVE TO BE THE BLENDING OF A FIRM CONCEPTION OF ALL USEFUL PRECEDENT AND THE PROGRESSIVE TENDENCIES OF AN ABLE MIND. FOR, LET A MAN BE AS ABLE AND ORIGINAL AS HE MAY, HE CANNOT AFFORD TO DISCARD KNOWLEDGE OF WHAT HAS GONE BEFORE OR WHAT IS NOW GOING ON IN HIS OWN TRADE AND PROFESSION. IF THE PRINTERS OF TODAY DO NOT WISH TO BE ESTERMED ARROGANT WHEN THEY TERM

Nos. 1 and 4

THE BEST KIND OF ORIGINALITY IS THAT WHICH COMES AFTER A SOUND APPRENTICESHIP; THAT WHICH SHALL PROVE TO BE THE BLENDING OF A FIRM CONCEPTION OF ALL USEFUL PRECEDENT AND THE PROGRESSIVE TENDENCIES OF AN ABLE MIND. FOR, LET A MAN BE AS ABLE AND ORIGINAL AS HE MAY, HE CANNOT AFFORD TO DISCARD KNOWLEDGE OF WHAT HAS GONE BEFORE OR WHAT IS NOW GOING ON IN HIS OWN TRADE AND PROFESSION. IF THE PRINTERS OF TODAY DO NOT WISH TO BE ESTERMED ARROGANT WHEN THEY TERM THIS CALLING OF THEIRS AN ART, THEY MUST BE WILLING, AND

Nos. 2 and 3

THE BEST KIND OF ORIGINALITY IS THAT WHICH COMES AFTER A SOUND APPRENTICESHIP; THAT WHICH SHALL PROVE TO BE THE BLENDING OF A FIRM CONCEPTION OF ALL USEFUL PRECEDENT AND THE PROGRESSIVE TENDENCIES OF AN ABLE MIND. FOR, LET A MAN BE AS ABLE AND ORIGINAL AS HE MAY, HE CANNOT AFFORD TO DISCARD KNOWLEDGE OF WHAT HAS GONE BEFORE OR WHAT IS NOW GOING ON IN HIS OWN TRADE AND PROFESSION. IF THE PRINTERS OF TODAY DO NOT WISH TO BE ESTERMED ARROGANT WHEN THEY TERM

Nos. 2 and 4

THE BEST KIND OF ORIGINALITY IS THAT WHICH COMES AFTER A SOUND APPRENTICESHIP; THAT WHICH SHALL PROVE TO BE THE BLENDING OF A FIRM CONCEPTION OF ALL USEFUL PRECEDENT AND THE PROGRESSIVE TENDENCIES OF AN ABLE MIND. FOR, LET A MAN BE AS ABLE AND ORIGINAL AS HE MAY, HE CANNOT AFFORD TO DISCARD KNOWLEDGE OF WHAT HAS GONE BEFORE OR WHAT IS NOW GOING ON IN HIS OWN TRADE AND PROFESSION. IF THE PRINTERS OF TODAY DO NOT WISH TO BE ESTERMED ARROGANT WHEN THEY TERM THIS CALLING OF THEIRS AN ART, THEY MUST BE WILLING, AND SHOW THAT

Nos. 3 and 4

THE VERY BEST KIND OF ORIGINALITY IS THAT WHICH COMES AFTER A SOUND APPRENTICESHIP; THAT WHICH SHALL PROVE TO BE THE BLENDING OF A FIRM CONCEPTION OF ALL USEFUL PRECEDENT AND THE PROGRESSIVE TENDENCIES OF AN ABLE MIND. FOR, LET A MAN BE AS ABLE AND ORIGINAL AS HE MAY, HE CANNOT AFFORD TO DISCARD KNOWLEDGE OF WHAT HAS GONE BEFORE OR WHAT IS NOW GOING ON IN HIS OWN TRADE AND PROFESSION. IF THE PRINTERS OF TODAY DO NOT WISH TO BE ESTERMED ARROGANT WHEN THEY TERM THIS CALLING OF

\*8 Point No. 223 In Preparation

\*10 Point No. 223

**FOR FINE STATIONERY PRINTING  
NEW. CLEAN. SHARP MONOTYPE TYPE FACES ARE  
NECESSARY TO GET GOOD RESULTS  
\$1234567890**

\*12 Point No. 223

**PRACTICE NON-DISTRIBUTION  
TO ATTAIN THE VERY BEST RESULTS  
IN YOUR PRESS ROOMS  
\$1234567890**

18 Point No. 223

**NON-DISTRIBUTION  
IS MORE ECONOMICAL THAN  
SPOTTING UP  
\$1234567890**

24 Point No. 223

**MONOTYPE TYPE  
SAVES MORE THAN  
IT COSTS  
\$1234567890**

\*The 8, 10, and 12 point sizes of this series are cast on the T mold, using the 12 point mold blade.

ELECTRO-DISPLAY MATRICES No. 223, shown on this page, are the same type design and are an extension of the 347J Series shown on the reverse side of this sheet

# TITLE [PLATE-GOTHIC] No. 348J SERIES

## ARRANGEMENT P-G—COMPOSITION MATRICES

Specimens of the four sizes contained in the matrix case, each size shown separately

6 Point No. 348J, 8 Set

No. 1

THE VERY BEST KIND OF ORIGINALITY IS THAT WHICH COMES AFTER A SOUND APPRENTICESHIP; THAT WHICH SHALL PROVE TO BE THE BLENDING OF A FIRM CONCEPTION OF ALL USEFUL PRECEDENT AND THE PROGRESSIVE TENDENCIES OF AN ABLE MIND. FOR, LET A MAN BE AS ABLE AND ORIGINAL AS HE MAY, HE CANNOT AFFORD TO DISCARD KNOWLEDGE OF WHAT HAS GONE BEFORE OR WHAT IS NOW GOING ON IN HIS OWN TRADE AND PROFESSION. IF THE PRINTERS OF TODAY DO NOT WISH TO BE ESTEEMED TOO ARROGANT WHEN THEY

ABCDEFGHIJKLMNPOQRSTUVWXYZ

\$1234567890

No. 2

THE VERY BEST KIND OF ORIGINALITY IS THAT WHICH COMES AFTER A SOUND APPRENTICESHIP; THAT WHICH SHALL PROVE TO BE THE BLENDING OF A FIRM CONCEPTION OF ALL USEFUL PRECEDENT AND THE PROGRESSIVE TENDENCIES OF AN ABLE MIND. FOR, LET A MAN BE AS ABLE AND ORIGINAL AS HE MAY, HE CANNOT AFFORD TO DISCARD KNOWLEDGE OF WHAT HAS GONE BEFORE OR WHAT IS NOW GOING ON IN HIS OWN TRADE AND PROFESSION. IF THE PRINTERS OF TODAY DO NOT WISH TO BE ESTEEMED ARROGANT WHEN THEY TERM THIS CALLING OF THEIRS AN ART, THEY MUST BE WILLING, AND SHOW THAT

ABCDEFGHIJKLMNPOQRSTUVWXYZ

\$1234567890

No. 3

THE VERY BEST KIND OF ORIGINALITY IS THAT WHICH COMES AFTER A SOUND APPRENTICESHIP; THAT WHICH SHALL PROVE TO BE THE BLENDING OF A FIRM CONCEPTION OF ALL USEFUL PRECEDENT AND THE PROGRESSIVE TENDENCIES OF AN ABLE MIND. FOR, LET A MAN BE AS ABLE AND ORIGINAL AS HE MAY, HE CANNOT AFFORD TO DISCARD A KNOWLEDGE OF WHAT HAS GONE BEFORE OR WHAT IS NOW GOING ON IN HIS OWN TRADE AND PROFESSION. IF THE PRINTERS OF TODAY DO NOT WISH TO BE ESTEEMED ARROGANT WHEN THEY TERM THIS CALLING OF THEIRS AN ART, THEY MUST BE WILLING, AND SHOW THAT THEY ARE WILLING, TO SUBJECT IT TO SUCH LAWS AS HAVE MADE ITS SISTER ARTS SO FREE. ALL THOSE CON-

ABCDEFGHIJKLMNPOQRSTUVWXYZ

\$1234567890

No. 4

THE BEST KIND OF ORIGINALITY IS THAT WHICH COMES AFTER A SOUND APPRENTICESHIP; THAT WHICH SHALL PROVE TO BE THE BLENDING OF A FIRM CONCEPTION OF ALL USEFUL PRECEDENT AND OF THE PROGRESSIVE TENDENCIES OF AN ABLE MIND. FOR, LET A MAN BE AS ABLE AND ORIGINAL AS HE MAY, HE CANNOT AFFORD TO DISCARD A KNOWLEDGE OF WHAT HAS GONE BEFORE OR WHAT IS NOW GOING ON IN HIS OWN TRADE AND PROFESSION. IF THE PRINTERS OF TODAY DO NOT WISH TO BE ESTEEMED ARROGANT WHEN THEY TERM THIS CALLING OF THEIRS AN ART, THEY MUST BE WILLING, AND SHOW THAT THEY ARE WILLING, TO SUBJECT IT TO SUCH LAWS AS HAVE MADE ITS SISTER ARTS SO FREE. ALL THOSE CONCERNED IN WHAT ARE ACCEPTED AS THE FINE ARTS, THE LEARNED SCIENCES, AND THE PROFESSIONS WILL SURROUND THEM-

ABCDEFGHIJKLMNPOQRSTUVWXYZ

\$1234567890

Specimens of all the possible cap and small cap combinations that can be made with the four sizes in the matrix case

6 Point No. 348J, 8 Set

Nos. 1 and 2

THE VERY BEST KIND OF ORIGINALITY IS THAT WHICH COMES AFTER A SOUND APPRENTICESHIP; THAT WHICH SHALL PROVE TO BE THE BLENDING OF A FIRM CONCEPTION OF ALL USEFUL PRECEDENT AND THE PROGRESSIVE TENDENCIES OF AN ABLE MIND. FOR, LET ANY MAN BE AS ABLE AND ORIGINAL AS HE MAY, HE CANNOT AFFORD TO DISCARD A KNOWLEDGE OF WHAT HAS GONE BEFORE OR WHAT IS NOW GOING ON IN HIS OWN TRADE AND PROFESSION.

Nos. 1 and 3

THE BEST KIND OF ORIGINALITY IS THAT WHICH COMES AFTER A SOUND APPRENTICESHIP; THAT WHICH SHALL PROVE TO BE THE BLENDING OF A FIRM CONCEPTION OF ALL USEFUL PRECEDENT AND THE PROGRESSIVE TENDENCIES OF AN ABLE MIND. FOR, LET A MAN BE AS ABLE AND ORIGINAL AS HE MAY, HE CANNOT AFFORD TO DISCARD KNOWLEDGE OF WHAT HAS GONE BEFORE OR WHAT IS NOW GOING ON IN HIS OWN TRADE AND HIS PROFESSION. IF THE PRINTERS OF TODAY DO NOT WISH TO BE ESTEEMED ARROGANT WHEN THEY TERM

Nos. 1 and 4

THE BEST KIND OF ORIGINALITY IS THAT WHICH COMES AFTER A SOUND APPRENTICESHIP; THAT WHICH SHALL PROVE TO BE THE BLENDING OF A FIRM CONCEPTION OF ALL USEFUL PRECEDENT AND THE PROGRESSIVE TENDENCIES OF AN ABLE MIND. FOR, LET A MAN BE AS ABLE AND ORIGINAL AS HE MAY, HE CANNOT AFFORD TO DISCARD KNOWLEDGE OF WHAT HAS GONE BEFORE OR WHAT IS NOW GOING ON IN HIS OWN TRADE AND PROFESSION. IF THE PRINTERS OF TODAY DO NOT WISH TO BE ESTEEMED ARROGANT WHEN THEY TERM THIS CALLING OF THEIRS AN ART, THEY MUST BE WILLING, AND

Nos. 2 and 3

THE VERY BEST KIND OF ORIGINALITY IS THAT WHICH COMES AFTER A SOUND APPRENTICESHIP; THAT WHICH SHALL PROVE TO BE THE BLENDING OF A FIRM CONCEPTION OF ALL USEFUL PRECEDENT AND THE PROGRESSIVE TENDENCIES OF AN ABLE MIND. FOR, LET A MAN BE AS ABLE AND ORIGINAL AS HE MAY, HE CANNOT AFFORD TO DISCARD KNOWLEDGE OF WHAT HAS GONE BEFORE OR WHAT IS NOW GOING ON IN HIS OWN TRADE AND PROFESSION. IF THE PRINTERS OF TODAY DO NOT WISH TO BE ESTEEMED ARROGANT WHEN THEY TERM THIS CALL-

Nos. 2 and 4

THE BEST KIND OF ORIGINALITY IS THAT WHICH COMES AFTER A SOUND APPRENTICESHIP; THAT WHICH SHALL PROVE TO BE THE BLENDING OF A FIRM CONCEPTION OF ALL USEFUL PRECEDENT AND THE PROGRESSIVE TENDENCIES OF AN ABLE MIND. FOR, LET A MAN BE AS ABLE AND ORIGINAL AS HE MAY, HE CANNOT AFFORD TO DISCARD KNOWLEDGE OF WHAT HAS GONE BEFORE OR WHAT IS NOW GOING ON IN HIS OWN TRADE AND PROFESSION. IF THE PRINTERS OF TODAY DO NOT WISH TO BE ESTEEMED ARROGANT WHEN THEY TERM THIS CALLING OF THEIRS AN ART, THEY MUST BE WILLING, AND SHOW THAT THEY

Nos. 3 and 4

THE VERY BEST KIND OF ORIGINALITY IS THAT WHICH COMES AFTER A SOUND APPRENTICESHIP; THAT WHICH SHALL PROVE TO BE THE BLENDING OF A FIRM CONCEPTION OF ALL USEFUL PRECEDENT AND THE PROGRESSIVE TENDENCIES OF AN ABLE MIND. FOR, LET A MAN BE AS ABLE AND ORIGINAL AS HE MAY, HE CANNOT AFFORD TO DISCARD KNOWLEDGE OF WHAT HAS GONE BEFORE OR WHAT IS NOW GOING ON IN HIS OWN TRADE AND PROFESSION. IF THE PRINTERS OF TODAY DO NOT WISH TO BE ESTEEMED ARROGANT WHEN THEY TERM THIS CALLING OF THEIRS

THE 348J Series is so arranged that all four sizes of six-point are carried in one Matrix Case. Thus, four sizes may be composed at one operation on the Keyboard, and cast in justified lines on the Casting Machine. At the Keyboard the right and left Keybars and Keybanks P-G and the Stopbars S108 are required, and at the Casting Machine the Normal Wedge S108 is required. A five-unit high space is required before the M and W of the six-point No. 1 size of the 348J Series.

When setting by hand, the following plan has been adopted. The six-point is cast to .0697 line. The sizes above six-point are Electro-Display Matrices designated as the No. 323 Series, shown on reverse of this sheet, and are a continuation of the 348J Series. The twelve-point is cast on its standard line .1250; to justify the six- with the twelve-point place four points above and two points below the six-point type. The nine-point will be cast on twelve-point body with the standard twelve-point line.

To justify together the twelve-, fourteen-, eighteen-, and twenty-four-point sizes, place all the spacing at the top. This makes all sizes line. The comma, semicolon, and tail of the Cap Q of the eighteen- and twenty-four-point size will overhang the body slightly.

The line standards for casting type for hand composition for Plate-Gothics according to the above plan will be as follows: Six-point .0697; nine-point on twelve-point body .1250; fourteen-point .1527; eighteen-point .2080; twenty-four-point .2910.

The Draw Rod should be readjusted to suit the movement of the Centering Pin when running on special line adjustment in order to produce the point line justification.



9 Point No. 323 In Preparation

14B Point No. 323

**INSURE SATISFACTION  
BY USING NEW MONOTYPE TITLE FACES AND  
ELIMINATE DISTRIBUTION  
\$1234567890**

14 Point No. 323

**WEAR AND TEAR  
IN THE PRESSROOM ARE OVERCOME  
BY NON-DISTRIBUTION  
\$1234567890**

18 Point No. 323

**BOUGHT TYPE  
IS AN EXPENSIVE LUXURY FOR  
ANY PRINTING OFFICE  
\$1234567890**

24 Point No. 323

**START NOW  
TO MAKE ALL YOUR OWN  
TYPE MATERIAL  
\$1234567890**

ELECTRO-DISPLAY MATRICES No. 323, shown on this page, are the same type design and are an extension of the 348J Series shown on the reverse side of this sheet. The nine-point size of this series is cast on the T-mold, using the twelve-point mold blade.

# No. 23K. Job Arrangement C2.

## Composition Matrices

6 Point No. 23K, 7 Set

### MONOTYPE FACES

The best kind of originality is that which comes after a sound apprenticeship; that which shall prove to be the blending of a firm conception of all useful precedent and the progressive tendencies of an able mind. For, let a man be as able and original as he may, he cannot afford to discard knowledge of what has gone before or what is now going on in his own trade and his profession. If the printers of today do not wish to be esteemed too arrogant when they term this calling of theirs an art, they must be willing, and show that they are willing, to subject it to such laws as have made its sister arts so free. All those concerned in what are accepted as the fine arts, the learned sciences and the professions, surround themselves with the history, the literature, and concrete examples of the work with which they are particularly engaged. Yet it is only in very rare instances that such an atmosphere, with all its material appurtenances, is to be found in a printing office. Art does not flourish in hidden places, nor under restraint, nor in ignorance of what talent and genius have accomplished and are now accomplishing throughout the world. For to follow precedent wisely does not mean to imitate slavishly one great exemplar, but to study all the masters faithfully, letting their great achievements sink slowly into the mind in order that we may patiently derive from the richness of our acquired knowledge and organized system an attitude of our own. The sprightly minded young man, who with his first business breath projects the new and startling, inevitably becomes tiresome, and he is driven to an early disappearance; while the slower and more solidly endowed student will at least spend as much of his time in avoiding mistakes as in evolving the brilliant schemes wherewith to dazzle his contemporaries. The best kind of originality is that which comes after a sound apprenticeship; that which

abcdefghijklmnopqrstuvwxy

ABCDEFGHIJKLMNPOQRSTUVWXYZ

\$1234567890

10 Point No. 23K, 10 Set

### MONOTYPE FACES

The best kind of originality is that which comes after a sound apprenticeship; that which shall prove itself to be the blending of a firm conception of all useful precedent and the progressive tendencies of an able mind. For, let a man be as able and as original as he may, he cannot afford to discard all knowledge of what has gone before or of what is now going on in his own trade and profession. If the printers of today do not wish to be esteemed arrogant when they term this calling of theirs an art, they must be willing, and show that they are willing, to subject it to such laws as have made its sister arts so free. All those concerned in what are accepted as the fine arts, the learned sciences and professions, surround themselves with the history, the literature, and concrete examples of the work with which they are particularly engaged. Yet it is only in rare instances that such an atmosphere, with its material appurtenances, is to be

abcdefghijklmnopqrstuvwxy

ABCDEFGHIJKLMNPOQRSTUVWXYZ

\$1234567890

8 Point No. 23K, 8 1/2 Set

### MONOTYPE FACES

The best kind of originality is that which comes after a sound apprenticeship; that which shall prove to be the blending of a firm conception of all useful precedent and of the progressive tendencies of an able mind. For, let any man be as able and as original as he may, he cannot afford to discard knowledge of what has gone before or what is now going on in his own trade and profession. If the printers of today do not wish to be esteemed arrogant when they term this calling of theirs an art, they must be willing, and show that they are willing, to subject it to such laws as have made its sister arts so free. All those concerned in what are accepted as the fine arts, the learned sciences and professions, surround themselves with the history, the literature, and concrete examples of the work with which they are particularly engaged. Yet it is only in rare instances that such an atmosphere, with its material appurtenances, is to be found in a printing office. Art does not flourish in hidden places, nor under restraint, nor in ignorance of what talent and genius have accomplished and are accomplishing throughout the world. For to follow precedent wisely does not mean to imitate slavishly one great exemplar,

abcdefghijklmnopqrstuvwxy

ABCDEFGHIJKLMNPOQRSTUVWXYZ

\$1234567890

12 Point No. 23K, 12 Set

### MONOTYPE FACES

The best kind of originality is that which comes after a sound apprenticeship; that which shall prove to be the blending of a firm conception of all useful precedent and the progressive tendencies of a clever mind. For, let any man be as able and original as he may, he cannot afford to discard a knowledge of what has gone before or what is now going on in his own trade and his profession. If the printers of today do not wish to be esteemed arrogant when they term this calling of theirs an art, they must be willing, and show that they are willing, to subject it to such laws as have made its sister arts so free. All those who are concerned in what

abcdefghijklmnopqrstuvwxy

ABCDEFGHIJKLMNPOQRSTUVWXYZ

\$1234567890

# No. 115C. Job Arrangement C2

## Composition Matrices

8 Point No. 115C, 8 Set

### MONOTYPE FACES

*The best kind of originality is that which comes after a sound apprenticeship; that which shall prove to be the blending of a firm conception of all useful precedent and the progressive tendencies of an able mind. For, let a man be as able and original as he may, he cannot afford to discard knowledge of what has gone before or what is now going on in his own trade and profession. If the printers of today do not wish to be esteemed too arrogant when they term this calling of theirs an art, they must be willing, and show that they are willing, to subject it to such laws as have made its sister arts so free. All those who are concerned in what are accepted as the fine arts, the learned sciences, and the professions surround themselves with the history, the literature, and concrete examples of the work with which they are particularly engaged. Yet it is only in rare instances that such an atmosphere, with its material appurtenances, is to be found in a printing office. Art does not flourish in any hidden places, nor under restraint, nor in ignorance of what both talent and genius have accomplished and are accomplishing throughout the world. For to follow precedent wisely does not mean to imitate slavishly one great exemplar, but to study all masters faithfully, letting their great*

abcdefghijklmnopqrstuvwxyz  
ABCDEFGHIJKLMNOPQRSTUVWXYZ  
\$1234567890

10 Point No. 115C, 10 Set

### MONOTYPE FACES

*The best kind of originality is that which comes after a sound apprenticeship; that which shall prove to be the blending of a firm conception of all useful precedent and the progressive tendencies of an able mind. For, let a man be as able and original as he may, he cannot afford to discard knowledge of what has gone before or what is now going on in his own trade and profession. If the printers of today do not wish to be esteemed too arrogant when they term this calling of theirs an art, they must be willing, and show that they are willing, to subject it to such laws as have made its sister arts so free. All those concerned in what are accepted as the fine arts, the learned sciences, and the professions surround themselves with the history, literature, and concrete examples of the work with which they are particularly engaged.*

abcdefghijklmnopqrstuvwxyz  
ABCDEFGHIJKLMNOPQRSTUVWXYZ  
\$1234567890

12 Point No. 115C, 12 Set

### MONOTYPE FACES

*The best kind of originality is that which comes after a sound apprenticeship; that which shall prove to be the blending of a firm conception of all useful precedent and the progressive tendencies of an able mind. For, let a man be as able and original as he may, he cannot afford to discard a knowledge of what has gone before or what is now going on in his own trade and profession. If the printers of today do not wish to be esteemed arrogant when they term this calling of theirs an art, then they must be willing, and show that they are willing, to subject it to such laws*

abcdefghijklmnopqrstuvwxyz  
ABCDEFGHIJKLMNOPQRSTUVWXYZ  
\$1234567890

### MONOTYPE FACES

*The best kind of originality is that which comes after a sound apprenticeship; that which shall prove to be the blending of a firm conception of all useful precedent and the progressive tendencies of an able mind. For, let a man be as able and original as he may, he cannot afford to discard a knowledge of what has gone before or what is now going on in his own trade and profession. If the printers of today do not wish to be esteemed arrogant when they term this calling of theirs an art, then they must be willing, and show that they are willing, to subject it to such laws as have made its sister arts so free. All those who are concerned in what*

# No. 12J. Job Arrangement C2

## Composition Matrices

8 Point No. 12J, 8½ Set

### MONOTYPE FACES

The best kind of originality is that which comes after a sound apprenticeship; that which shall prove to be the blending of a firm conception of all useful precedent and the progressive tendencies of an able mind. For, let a man be as able and original as he may, he cannot afford to discard knowledge of what has gone before or what is now going on in his own trade and profession. If the printers of today do not wish to be esteemed arrogant when they term this calling of theirs an art, they must be willing, and show that they are willing, to subject it to such laws as have made its sister arts so free. All those concerned in what are accepted as the fine arts, the learned sciences, and professions surround themselves with the history, literature, and concrete examples of the work with which they are particularly engaged. Yet it is only in very rare instances that such an atmosphere, with its material appurtenances, is to be found in a printing office. Art does not flourish in hidden places, nor under restraint, nor in ignorance of what talent and genius have accomplished and are accomplishing throughout the world. For to follow precedent wisely does not mean to imitate slavishly one great exemplar,

abcdefghijklmnopqrstuvwxy  
ABCDEFGHIJKLMNOPQRSTUVWXYZ  
\$1234567890

10 Point No. 12J, 10½ Set

### MONOTYPE FACES

The best kind of originality is that which comes after a sound apprenticeship; that which shall prove to be the blending of a firm conception of all useful precedent and the progressive tendencies of an able mind. For, let any man be as able and original as he may, he cannot afford to discard knowledge of what has gone before or what is now going on in his own trade and profession. If the printers of today do not wish to be esteemed too arrogant when they term this calling of theirs an art, they must be willing, and show that they are willing, to subject it to such laws as have made its sister arts so very free. All those concerned in what are accepted as the fine arts, the learned sciences, and professions surround themselves with the history, literature, and concrete examples

abcdefghijklmnopqrstuvwxy  
ABCDEFGHIJKLMNOPQRSTUVWXYZ  
\$1234567890

12 Point No. 12J, 12 Set

### MONOTYPE FACES

The best kind of originality is that which comes after a sound apprenticeship; that which shall prove to be the blending of a firm conception of all useful precedent and the progressive tendencies of an able mind. For, let a man be as able and original as he may, he cannot afford to discard a knowledge of what has gone before or what is now going on in his own trade and profession. If the printers of today do not wish to be esteemed arrogant when they term this calling of their an art, they must be willing, and show that they are willing, to subject it to such laws

abcdefghijklmnopqrstuvwxy  
ABCDEFGHIJKLMNOPQRSTUVWXYZ  
\$1234567890

### MONOTYPE FACES

The best kind of originality is that which comes after a sound apprenticeship; that which shall prove to be the blending of a firm conception of all useful precedent and the progressive tendencies of an able mind. For, let a man be as able and original as he may, he cannot afford to discard a knowledge of what has gone before or what is now going on in his own trade and profession. If the printers of today do not wish to be esteemed arrogant when they term this calling of theirs an art, they must be willing, and show that they are willing, to subject it to such laws as have made its sister arts so free. All those who are concerned in what

14 Point No. 12

**MONOTYPE SAVES AT BOTH ENDS**

The Monotype Will Decrease Your Composition Costs and Multiply  
Your Composing Room Profits  
\$1234567890

18 Point No. 12

**NO LONG WAITS OR SHORT WEIGHTS**

About Monotype Fonts, Cast as much as you Need just  
as Soon as you Need It  
\$1234567890

24 Point No. 12

**THE LIBRARY SYSTEM**

Gives Choice of a Large Number of Faces  
At a Nominal Cost  
\$1234567890

30 Point No. 12

**DISPLAY TYPE**

That will Stand Long Runs and will  
Electrotype Perfectly  
\$1234567890

36 Point No. 12

**A SAVING**

Is Made in Very Many Ways  
\$1234567890

18 Point No. 40

A GOOD WORKMAN REJOICES  
 At the Beautiful Faces as Well as the Unlimited  
 Sorts Supplied by the Monotype  
 \$1234567890

20 Point No. 40

THE SATISFIED MAN  
 Is a Business Asset, Whether He is a  
 Customer or a Workman  
 \$1234567890

24 Point No. 40

INDIVIDUALITY  
 In Type Makes For Fine as Well  
 as Correct Work  
 \$1234567890

36 Point No. 40

THE RESULT  
 Holds Your Customers  
 \$1234567890

14 Point No. 41

**MONOTYPE SUCCESS**

*Is Demonstrated by the Demand for Good Operators from  
Our Free School of Instruction  
\$1234567890*

18 Point No. 41

**TWENTY-SIX KEYBOARDS**

*And Twenty-four Casters are used Exclusively for  
Instruction Purposes in our School  
\$1234567890*

24 Point No. 41

**COMMERCIAL PRINTERS**

*Use the Monotype on Books, Catalogs,  
Tariffs and Magazines  
\$1234567890*

30 Point No. 41

**16 POUNDS PER HOUR**

*New Type Cast by a New Orleans  
Daily on the Monotype  
\$1234567890*

36 Point No. 41

**YOUR TYPE FOUNDRY**

*Complete for Making Type  
\$1234567890*

\*12 point No. 41K 12 set, Job Arrangement C2. Composition Matrices, same face as specimens shown above can be purchased.

# No. 42J. Job Arrangement C2

## Composition Matrices

8 Point No. 42J, 8½ Set

### MONOTYPE FACES

The best kind of originality is that which comes after a sound apprenticeship; that which shall prove to be the blending of a firm conception of all useful precedent and the progressive tendencies of an able mind. For, let a man be as able and original as he may, he cannot afford to discard knowledge of what has gone before or what is now going on in his own trade and profession. If the printers of today do not wish to be esteemed arrogant when they term this calling of theirs an art, they must be willing, and show that they are willing, to subject it to such laws as have made its sister arts so free. All those concerned in what are accepted as the fine arts, the learned sciences, and professions surround themselves with the history, literature, and concrete examples of the work with which they are particularly engaged. Yet it is only in very rare instances that such an atmosphere, with its material appurtenances, is to be found in a printing office. Art does not flourish in hidden places, nor under restraint, nor in ignorance of what talent and genius have accomplished and are accomplishing throughout the world. For to follow precedent wisely does not mean to imitate slavishly one great exemplar,

abcdefghijklmnopqrstuvwxy  
ABCDEFGHIJKLMNopQRSTUVWXYZ  
\$1234567890

10 Point No. 42J, 10 Set

### MONOTYPE FACES

The best kind of originality is that which comes after a sound apprenticeship; that which shall prove to be the blending of a firm conception of all useful precedent and the progressive tendencies of an able mind. For, let a man be as able and original as he may, he cannot afford to discard knowledge of what has gone before or what is now going on in his own trade and profession. If the printers of today do not wish to be esteemed too arrogant when they term this calling of theirs an art, they must be willing, and show that they are willing, to subject it to such laws as have made its sister arts so free. All those concerned in what are accepted as the fine arts, the learned sciences, and professions surround themselves with the history, literature, and concrete examples of the work with which they are particularly engaged.

abcdefghijklmnopqrstuvwxy  
ABCDEFGHIJKLMNopQRSTUVWXYZ  
\$1234567890

12 Point No. 42J, 12 Set

### MONOTYPE FACES

The best kind of originality is that which comes after a sound apprenticeship; that which shall prove to be the blending of a firm conception of all useful precedent and the progressive tendencies of an able mind. For, let a man be as able and original as he may, he cannot afford to discard a knowledge of what has gone before or what is now going on in his own trade and profession. If the printers of today do not wish to be esteemed arrogant when they term this calling of theirs an art, they must be willing, and show that they are willing, to subject it to such laws

abcdefghijklmnopqrstuvwxy  
ABCDEFGHIJKLMNopQRSTUVWXYZ  
\$1234567890

### MONOTYPE FACES

The best kind of originality is that which comes after a sound apprenticeship; that which shall prove to be the blending of a firm conception of all useful precedent and the progressive tendencies of an able mind. For, let a man be as able and original as he may, he cannot afford to discard a knowledge of what has gone before or what is now going on in his own trade and profession. If the printers of today do not wish to be esteemed arrogant when they term this calling of theirs an art, they must be willing, and show that they are willing, to subject it to such laws as have made its sister arts so free. All those who are concerned in what



No. 42

Electro Display Matrices

14 Point No. 42

**THE MONOTYPE UNIT SYSTEM**  
Means More than Most People May Realize. It Applies to Caster,  
Keyboard, Matrices and Type  
\$1234567890

18 Point No. 42

**EVERY MATRIX IS A UNIT**  
Every Part of the Monotype Keyboard or Caster and  
Every Improvement on Either is a Unit  
\$1234567890

24 Point No. 42

**AND EACH AND EVERY UNIT**  
Can be Supplied and Easily Fitted to  
Your Machine at Small Expense  
\$1234567890

30 Point No. 42

**BUY WHAT YOU NEED**  
And as your Plant Grows add  
the Parts to Suit your Trade  
\$1234567890

36 Point No. 42

**WHAT YOU WANT**  
When You Want It Most  
\$1234567890

14 Point No. 44

**MONOTYPE MAKES MONEY**

Because the Typographic Quality of its Work in Every Department  
Attracts and Holds Customers

**\$1234567890**

18 Point No. 44

**BOOK AND JOB PRINTERS**

Everywhere state that the Monotype Pleases Their  
Most Particular Customers

**\$1234567890**

24 Point No. 44

**HEIGHT-TO-PAPER**

Absolutely True for Every Type Cast  
on the Monotype

**\$1234567890**

30 Point No. 44

**NEVER OUT OF SORTS**

No Job Requires More Type than  
the Monotype can Furnish

**\$1234567890**

36 Point No. 44

**SAVES AND EARNS**

Money on All kinds of Work

**\$1234567890**

30 Point No. 59

FOREIGN LANGUAGE WORK  
 Changes from one Language to any  
 Other Made Easily  
 \$1234567890

36 Point No. 59

THE ELASTIC MACHINE  
 Makes the Face Fit the Space  
 \$1234567890

24 Point No. 73

HEIGHT TO PAPER  
 MONOTYPE ACCURACY  
 SAVES MAKE-READY  
 \$1234567890

# No. 96J. Job Arrangement C1

## Composition Matrices

10 Point No. 96J, 9½ Set

### MONOTYPE FACES

The best kind of originality is that which comes after a sound apprenticeship; that which shall prove to be the blending of a firm conception of all useful precedent and the progressive tendencies of an able mind. For, let a man be as able and original as he may, he cannot afford to discard knowledge of what has gone before or what is now going on in his own trade and profession. If the printers of today do not wish to be esteemed too arrogant when they term this calling of theirs an art, they must be willing, and show that they are willing, to subject it to such laws as have made its sister arts so free. All those concerned in what are accepted as the fine arts, the learned sciences and professions, surround themselves with the history, literature, and concrete examples of the work with which they are particularly engaged. Yet it is only in very rare instances that

abcdefghijklmnopqrstuvwxy z

ABCDEFGHIJKLMN OPQRSTUVWXYZ

\$1234567890

### MONOTYPE FACES

The best kind of originality is that which comes after a sound apprenticeship; that which shall prove to be the blending of a firm conception of all useful precedent and the progressive tendencies of an able mind. For, let a man be as able and original as he may, he cannot afford to discard knowledge of what has gone before or what is now going on in his own trade and profession. If the printers of today do not wish to be esteemed too arrogant when they term this calling of theirs an art, they must be willing, and show that they are willing, to subject it to such laws as have made its sister arts so free. All those concerned in what are accepted as the fine arts, the learned sciences and professions, surround themselves with the history, literature, and concrete examples of the work with which they are particularly engaged. Yet it is only in very rare instances that such an atmosphere, with its material appurtenances, is to be found in a printing office. Art does not flourish in hidden places, nor under restraint, nor in ignor-

12 Point No. 96J, 11 Set

### MONOTYPE FACES

The best kind of originality is that which comes after a sound apprenticeship; that which shall prove to be the blending of a firm conception of all useful precedent and the progressive tendencies of an able mind. For, let a man be as able and original as he may, he cannot afford to discard knowledge of what has gone before or what is now going on in his own trade and profession. If the printers of today do not wish to be esteemed too arrogant when they term this calling of theirs an art, they must be willing, and show that they are willing, to subject it to such laws as have made its sister arts so free. All those concerned in what are accepted as the fine arts, the learned sciences and profes-

abcdefghijklmnopqrstuvwxy z

ABCDEFGHIJKLMN OPQRSTUVWXYZ

\$1234567890

### MONOTYPE FACES

The best kind of originality is that which comes after a sound apprenticeship; that which shall prove to be the blending of a firm conception of all useful precedent and the progressive tendencies of an able mind. For, let a man be as able and original as he may, he cannot afford to discard knowledge of what has gone before or what is now going on in his own trade and profession. If the printers of today do not wish to be esteemed too arrogant when they term this calling of theirs an art, they must be willing, and show that they are willing, to subject it to such laws as have made its sister arts so free. All those concerned in what are accepted as the fine arts, the learned sciences and professions, surround themselves with the history, literature, and concrete examples of the work

18 Point No. 96

ONE NEWSPAPER CUSTOMER SAYS  
Since the Monotypes were Installed they haven't bought a Dollar's Worth  
of Type, Spacing Material or Borders  
\$1234567890

24 Point No. 96

“PRINTING FOR PROFIT”  
Is Our Answer to that Interesting Query, “What  
is the Matter with the Printing Business?”  
\$1234567890

30 Point No. 96

QUALITY PAYS HANDSOMELY  
It is the Best and Only Lever to Raise  
Prices and Increase Your Profits  
\$1234567890

36 Point No. 96

WHY NOT USE  
New Type for Every Job? Another  
Monotype Advantage  
\$1234567890

NOTE: Two styles of Capitals M and O are furnished with fonts of the above series unless customer's order specifically states that only one style is desired. When ordering single characters, be sure to state whether the regular or special wide characters are desired.

18 Point No. 123

CUSTOMERS PRAISE THEIR PRINTERS  
FOR IMPROVING THE QUALITY OF THEIR WORK WITHOUT  
INCREASING ITS COST  
\$1234567890

24 Point No. 123

OUR RECENT IMPROVEMENTS  
HAVE MADE THE MONOTYPE NEWER AND MORE  
SERVICEABLE. LET US TELL YOU ABOUT IT  
\$1234567890

36 Point No. 123

THE NEW KEYBOARD, MOLD  
AND MATRIX EASILY ESTABLISH A  
RECORD FOR IMPROVEMENTS  
\$1234567890

12 Point No. 193

**MONOTYPE CONTINUOUS PRODUCTION**  
**Minimum Cost Results from Continuous Production; Machines**  
**that Handicap the Orderly Progress of Work are**  
**Profit Eaters and an Expense**  
**\$1234567890**

18 Point No. 193

**NO BACK-TRACKING**  
**Composition, Corrections and Alterations**  
**go on Side by Side Without Friction**  
**\$1234567890**

24 Point No. 193

**SELLING HELPS**  
**Machines Cannot Earn Profits Un-**  
**less They Help You Sell**  
**\$1234567890**

30 Point No. 193

**POINTS THAT**  
**Determine Money Returns**  
**\$1234567890**

36 Point No. 193

**MONOTYPE**  
**Means Quality & Service**  
**\$1234567890**

12 Point No. 202

**SAVING THE DISTRIBUTION EXPENSE**

**Full Cases of New Type and Rule Saves Distribution Expense, and  
the Monotype Makes New Type and Rule Cheaper than a  
Compositor Can Distribute Worn Type and Rule  
\$1234567890**

14 Point No. 202

**COST OF NON-PRODUCTIVE HOURS  
BEFORE YOU GET ANY PROFIT YOU MUST FIRST  
EARN THE COST OF NOT RUNNING A  
MACHINE AS WELL AS THE  
COST OF RUNNING IT  
\$1234567890**

18 Point No. 202

**THE MONOTYPE  
Is Always Producing New Matter or Type  
for the Cases up to 36 Point,  
Spacos, Leads, Rules, etc.  
\$1234567890**

24 Point No. 202

**THE MONOTYPE  
Gives Maximum Production for  
It is Continuously Producing  
\$1234567890**



Extra Price Matrices. Fonts shown on this page  
Not Included in Library and Will Not be Leased

12B Point No. 246

**SHADED TYPE FACES  
ARE IN GREAT DEMAND, BUT A GREAT EXPENSE TO THE  
PRINTER WITHOUT A MONOTYPE  
\$1234567890**

12 Point No. 246

**FILL YOUR CASES  
WITH THIS POPULAR SERIES AND USE  
FRESH NEW TYPE FOR EVERY JOB  
\$1234567890**

16 Point No. 246

**CLASSIC CAPITALS  
SUITED TO A GREAT VARIETY  
OF PROFITABLE USES  
\$1234567890**

# No. 95J. Job Arrangement C3

## Composition Matrices

6 Point No. 95J, 7½ Set

### Monotype Faces

The best kind of originality is that which comes after a sound apprenticeship; that which shall prove to be the blending of a firm conception of all useful precedent and the progressive tendencies of an able mind. For, let a man be as able and as original as he may, he cannot afford to discard knowledge of what has gone before or what is now going on in his own trade and profession. If the printers of today do not wish to be esteemed arrogant when they term this calling of theirs an art, they must be willing, and show that they are willing, to subject it to such laws as have made its sister arts so free. All those concerned in what are now accepted as the fine arts, the learned sciences and professions, surround themselves with the history, literature, and the concrete examples of the work with which they are particularly engaged. Yet it is only in very rare instances that this atmosphere, with its material appurtenances, is to be found in a printing office. Art does not flourish in hidden places, nor under restraint, nor in ignorance of what talent and genius have accomplished and are now accomplishing throughout the world. For to follow all precedent wisely does not mean to imitate too slavishly one great exemplar, but to study all masters faithfully, letting their great achievements sink slowly into the mind in order that we may patiently derive from the richness of our acquired knowledge and organized system an attitude of our own. The sprightly minded young man, who with his first business breath projects the new and startling, inevitably becomes tiresome, and is driven to an early disappearance; while the slower, more solidly endowed student will at least spend as much of his time in absorbing mistakes as in evolving brilliant schemes wherewith to dazzle his contemporaries. The best kind of originality is that which comes after a sound apprenticeship; that which shall prove to be the blending of a firm conception of all useful precedent and the progressive tendencies of an able mind. For, let a man be as able and original as he may, he cannot afford to discard knowledge of what has gone before or what is now going on in his own trade and profession. If the printers of today do not wish to be esteemed arrogant when they term this calling of theirs an art, they must be willing, and show that they are willing, to subject it

abcdefghijklmnopqrstuvwxyz

ABCDEFGHIJKLMN O PQRSTU VWXYZ

\$1234567890

10 Point No. 95J, 11 Set

### Monotype Faces

The best kind of originality is that which comes after a thorough apprenticeship; that which shall prove to be the blending of a firm conception of all useful precedent and the progressive tendencies of a very able mind. For, let a man be as able and original as he may, he cannot afford to discard knowledge of what has gone before or what is now going on in his own trade and profession. If the printers of today do not wish to be esteemed arrogant when they term this calling of theirs an art, they must be willing, and show that they are willing, to subject it to such laws as have made all its sister arts so free. All those concerned in what are accepted as the fine arts, the learned sciences, and professions, surround themselves with the history, literature, and concrete examples of the work with which they are particularly engaged. Yet it is only in rare instances that such an atmosphere, with its material appurtenances, is to be found in a printing office. Art does not flourish in the hidden places, nor under restraint, nor in ignorance of what talent and genius have accomplished and are now accomplishing throughout the world. For to follow all precedent wisely does

abcdefghijklmnopqrstuvwxyz

ABCDEFGHIJKLMN O PQRSTU VWXYZ

\$1234567890

8 Point No. 95J, 9 Set

### Monotype Faces

The best kind of originality is that which comes after a sound apprenticeship; that which shall prove to be the blending of a firm conception of all useful precedent and of the progressive tendencies of an able mind. For, let a man be as able and original as he may, he cannot afford to discard knowledge of what has gone before or what is now going on in his own trade and profession. If the printers of today do not wish to be esteemed arrogant when they term this calling of theirs an art, they must be willing, and show that they are willing, to subject it to such laws as have made its sister arts so free. All those concerned in what are accepted as the fine arts, the learned sciences, and professions, surround themselves with the history, the literature, and the concrete examples of the work with which they are particularly engaged. Yet it is only in rare instances that such an atmosphere, with its material appurtenances, is to be found in a printing office. Art does not flourish in the hidden places, nor under restraint, nor in ignorance of what talent and genius have accomplished and are accomplishing throughout the world. For to follow precedent wisely does not mean to imitate slavishly one great exemplar, but to study all masters faithfully, letting their great achievements sink slowly into the mind in order that we may patiently derive from the richness of our acquired knowledge and organized system an attitude of our own. The

abcdefghijklmnopqrstuvwxyz

ABCDEFGHIJKLMN O PQRSTU VWXYZ

\$1234567890

12 Point No. 95J, 12½ Set

### Monotype Faces

The best kind of originality is that which comes after a sound apprenticeship; that which shall prove to be the blending of a firm conception of all useful precedent and the progressive tendencies of an able mind. For, let any man be as able and original as he may, he cannot afford to discard a knowledge of what has gone before or what is now going on in his own trade and profession. If the printers of today do not wish to be esteemed arrogant when they term this calling of theirs an art, they must be willing, and show that they are willing, to subject it to such laws as have made its sister arts so free. All those concerned in what are accepted as the fine arts, the learned sciences, and the professions, surround themselves with the history, literature,

abcdefghijklmnopqrstuvwxyz

ABCDEFGHIJKLMN O PQRSTU VWXYZ

\$1234567890

14 Point No. 95

Ask the Man who Owns a Monotype  
He will tell you that it will Handle all of the Work in the Composing Room;  
that no job is too Plain or Intricate for Profit Making  
\$1234567890

18 Point No. 95

You are after the Big Work  
Yet if you do not have the Proper Equipment you are Bound  
to Lose out in the end  
\$1234567890

24 Point No. 95

A Monotype Plant  
Will get out all the Work on Time for a Certain  
and Satisfactory Profit  
\$1234567890

30 Point No. 95

The Beautiful Work of the  
Monotype is a Business-Builder that is  
Better than Low Prices  
\$1234567890

36 Point No. 95

Plenty of Sorts  
Keep Your Employees Satisfied  
\$1234567890

# No. 102J. Job Arrangement C3

## Composition Matrices

6 Point No. 102J, 7½ Set

### Monotype Faces

The best kind of originality is that which comes after a sound apprenticeship; that which shall prove to be the blending of a firm conception of all useful precedent and of the progressive tendencies of an able mind. For, let a man be as able and original as he may, he cannot afford to discard knowledge of what has gone before or what is now going on in his own trade and profession. If the printers of today do not wish to be esteemed arrogant when they term this calling of theirs an art, they must be willing, and show that they are willing, to subject it to such laws as have made its sister arts so free. All those concerned in what are accepted as the fine arts, the learned sciences, and professions, surround themselves with the history, the literature, and the concrete examples of the work with which they are particularly engaged. Yet it is only in rare instances that such an atmosphere, with its material appurtenances, is to be found in a printing office. Art does not flourish in the hidden places, nor under restraint, nor in ignorance of what talent and genius have accomplished and are accomplishing throughout the world. For to follow precedent wisely does not mean to imitate slavishly one great exemplar, but to study all masters faithfully, letting their great achievements sink slowly into the mind in order that we may patiently derive from the richness of our acquired knowledge and organized system an attitude of our own. The sprightly minded young man, who with his first business breath projects the new and startling, inevitably becomes tiresome, and is driven to an early disappearance; while the slower, more solidly endowed student will at least spend as much time in avoiding mistakes as in evolving brilliant schemes wherewith to dazzle his contemporaries. The best kind of originality is that which comes after a sound apprenticeship; that which shall prove to be the blending of a firm conception of all useful precedent and of the progressive tendencies of an able mind. For, let a man be as able and original as he may, he cannot afford to discard knowledge of what has gone before or what is now going on in his own trade and profession. If the printers of today do not wish to be esteemed arrogant when they term

abcdefghijklmnopqrstuvwxyz

ABCDEFGHIJKLMN O P Q R S T U V W X Y Z

\$1234567890

10 Point No. 102J, 11 Set

### Monotype Faces

The best kind of originality is that which comes after a thorough apprenticeship; that which shall prove to be the blending of a firm conception of all useful precedent and the progressive tendencies of a very able mind. For, let a man be as able and original as he may, he cannot afford to discard knowledge of what has gone before or what is now going on in his own trade and profession. If the printers of today do not wish to be esteemed arrogant when they term this calling of theirs an art, they must be willing, and show that they are willing, to subject it to such laws as have made all its sister arts so free. All those concerned in what are accepted as the fine arts, the learned sciences, and professions, surround themselves with the history, literature, and concrete examples of the work with which they are particularly engaged. Yet it is only in rare instances that such an atmosphere, with its material appurtenances, is to be found in a printing office. Art does not flourish in the hidden places, nor under restraint, nor in ignorance of what talent

abcdefghijklmnopqrstuvwxyz

ABCDEFGHIJKLMN O P Q R S T U V W X Y Z

\$1234567890

8 Point No. 102J, 9 Set

### Monotype Faces

The best kind of originality is that which comes after a sound apprenticeship; that which shall prove to be the blending of a firm conception of all useful precedent and of the progressive tendencies of an able mind. For, let a man be as able and original as he may, he cannot afford to discard knowledge of what has gone before or what is now going on in his own trade and profession. If the printers of today do not wish to be esteemed arrogant when they term this calling of theirs an art, they must be willing, and show that they are willing, to subject it to such laws as have made its sister arts so free. All those concerned in what are accepted as the fine arts, the learned sciences, and professions, surround themselves with the history, the literature, and the concrete examples of the work with which they are particularly engaged. Yet it is only in rare instances that such an atmosphere, with its material appurtenances, is to be found in a printing office. Art does not flourish in hidden places, nor under restraint, nor in ignorance of what talent and genius have accomplished and are accomplishing throughout the world. For to follow precedent wisely does not mean to imitate slavishly one great exemplar, but to study all masters faithfully, letting their great achievements sink slowly into the mind in order that we may patiently derive from the richness of our acquired knowledge and organized system an attitude of our own.

abcdefghijklmnopqrstuvwxyz

ABCDEFGHIJKLMN O P Q R S T U V W X Y Z

\$1234567890

12 Point No. 102J, 12½ Set

### Monotype Faces

The best kind of originality is that which comes after a sound apprenticeship; that which shall prove to be the blending of a firm conception of all useful precedent and the progressive tendencies of an able mind. For, let any man be as able and original as he may, he cannot afford to discard knowledge of what has gone before or what is now going on in his own trade and profession. If the printers of today do not wish to be esteemed arrogant when they term this calling of theirs an art, they must be willing, and show that they are willing, to subject it to such laws as have made its sister arts so free. All those concerned in what are accepted as the fine arts, the learned sciences, and the professions, surround themselves with the history, literature,

abcdefghijklmnopqrstuvwxyz

ABCDEFGHIJKLMN O P Q R S T U V W X Y Z

\$1234567890

14 Point No. 102

The Art Preservative of Arts  
Gained a Friend in Need Through the Invention of the Monotype Machine  
It Maintains the Quality Standard  
\$1234567890

18 Point No. 102

All Other Composing Machines  
Tended Simply to Increased Output Without Regard to the  
Quality of the Type and Letterpress  
\$1234567890

24 Point No. 102

Without Any Doubt  
Both Quantity and Quality Were Attained by  
the Monotype Alone  
\$1234567890

30 Point No. 102

It Stands By Itself  
As the Machine Suited to the Very  
Highest Class of Printing  
\$1234567890

36 Point No. 102

The Entire Field  
Is Covered by the Monotype Only  
\$1234567890

# No. 188J. Job Arrangement C2

## Composition Matrices

6 Point No. 188J, 7½ Set

### Monotype Faces

The best kind of originality is that which comes after a sound apprenticeship; that which shall prove to be the blending of a firm conception of all useful precedent and the progressive tendencies of an able mind. Nor, let a man be as able and original as he may, he cannot afford to discard knowledge of what has gone before or what is now going on in his own trade and profession. If the printers of today do not wish to be esteemed arrogant when they term this calling of theirs an art, they must be willing, and show that they are willing, to subject it to such laws as have made its sister arts so free. All those concerned in what are accepted as the fine arts, the learned sciences, and professions surround themselves with the history, literature, and concrete examples of the work with which they are particularly engaged. Yet it is only in rare instances that such an atmosphere, with its material appurtenances, is to be found in a printing office. Art does not flourish in hidden places, nor under restraint, nor in ignorance of what talent and genius have accomplished and are accomplishing throughout the world. Nor to follow precedent wisely does not mean to imitate slavishly one great exemplar, but to study all masters faithfully, letting their great achievements sink slowly into the mind in order that he may patiently derive from the richness of our acquired knowledge and organized system an attitude of our own. The uprightly minded young man, who with his first business breath protects the new and startling, inevitably becomes tiresome, and is driven to an early disappearance; while the slower, more solidly endowed student will at least spend as much of his time in avoiding mistakes as in evolving brilliant schemes wherewith to dazzle his contemporaries.

abcdefghijklmnopqrstuvwxyz  
ABCDEFGHIJKLMN O PQRSTU VWXYZ  
\$1234567890

10 Point No. 188J, 11 Set

### Monotype Faces

The very best kind of originality is that which comes after a sound apprenticeship; that which shall prove itself to be the blending of a firm conception of all useful precedent and the progressive tendencies of an able mind. Let any man be as able and original as he may, he cannot afford to discard knowledge of what has gone before or what is now going on in his own trade and profession. If the printers of today do not wish to be esteemed arrogant when they term this calling of theirs an art, they must be willing, and show that they are willing, to subject it to such laws as have made its sister arts so free. All those concerned in what are accepted as the fine arts, the learned sciences, and professions surround themselves with the history, literature, and concrete examples of the work with which they are particularly engaged. Yet it is only in

abcdefghijklmnopqrstuvwxyz  
ABCDEFGHIJKLMN O PQRSTU VWXYZ  
\$1234567890

8 Point No. 188J, 9 Set

### Monotype Faces

The best kind of originality is that which comes after a sound apprenticeship; that which shall prove to be the blending of a firm conception of all useful precedent and of the progressive tendencies of an able mind. Nor, let a man be as able and original as he may, he cannot afford to discard knowledge of what has gone before or what is now going on in his own trade and profession. If the printers of today do not wish to be esteemed arrogant when they term this calling of theirs an art, they must be willing, and show that they are willing, to subject it to such laws as have made its sister arts so free. All those concerned in what are accepted as the fine arts, the learned sciences, and professions surround themselves with the history, the literature, and concrete examples of the work with which they are particularly engaged. Yet it is only in rare instances that such an atmosphere, with its material appurtenances, is to be found in a printing office. Art does not flourish in hidden places, nor under restraint, nor in ignorance of what talent and genius have already accomplished and are accomplishing throughout all the world. Nor to

abcdefghijklmnopqrstuvwxyz  
ABCDEFGHIJKLMN O PQRSTU VWXYZ  
\$1234567890

12 Point No. 188J, 12½ Set

### Monotype Faces

The best kind of originality is that which comes after a sound apprenticeship; that which shall prove to be the blending of a firm conception of all useful precedent and the progressive tendencies of a clever mind. Nor, let a man be as able and original as he may, he cannot afford to discard a knowledge of what has gone before or what is now going on in his own trade and profession. If the printers of today do not wish to be esteemed arrogant when they term this calling of theirs an art, they must be willing, and show that they are willing, to subject it to such laws as have made its sister arts so free. All those who

abcdefghijklmnopqrstuvwxyz  
ABCDEFGHIJKLMN O PQRSTU VWXYZ  
\$1234567890

14 Point No. 188

**A Good Black Letter**

**Is a Necessity in Every Composing Room. This Good Series  
Will Prove Useful for Announcements, etc.**

**\$1234567890**

18 Point No. 188

**Good Type Faces**

**Make Your Composing Room the Right Hand of  
Your Sales Department**

**\$1234567890**

24 Point No. 188

**The Monotype**

**Is the Composing Machine that Helps  
You Sell Good Printing**

**\$1234567890**

No. 75 (No. 475 German)

Electro Display Matrices

18 Point No. 75

**Stop the Leak of Idle Time**

**No Machine is Worth Having when you Can't Run it as an Actual  
Producer on Live Copy all the Time**

**\$1234567890**

This series is also designated as No. 475 and is made up of our No. 75 series, together with the additional characters necessary to complete the German font. In ordering, specify the proper point size and the series, No. 475. You will receive characters which are marked 75, including the extra characters to complete the German.

# No. 17L, Typewriter

## Composition Matrices

This face can be run on any Keyboard arrangement, but must be used on a Keyboard equipped with the typewriter stop.

11 Point No. 17L, Set Size .100"

Mr. Progressive Printer,  
Everywhere.

Dear Sir:

This is a sample of our 11 point No. 17L, a typewriter face designed to overcome printing through a ribbon in order to obtain the rough, fuzzy effect of typewriter work. The face of the type is slightly thicker, and the outer edges of the letters more uneven than typewriter characters designed for use with a ribbon.

There is a great and increasing demand for this class of work. The printer who can print form letters properly has a profitable specialty, and in these days specialty printing is fast becoming a profitable field for the printer.

This is an especially useful face for fac-simile work, with copying ink, or for circulars printed in black ink only. It is shown in this specimen printed in purple copying ink through a ribbon and direct from the type.

For the general run of duplicating this is one of the best typewriter faces ever designed. The regular font consists of 93 characters, and includes the common fractions and commercial signs in general use. The set size of each character in this series is .100 or 10 letters to the inch.

12345 ABCDEFGHIJKLMNOPQRSTUVWXYZ& 67890\$

abcdefghijklmnopqrstuvwxyz

.,'"()!?-:;%/#\$@£-

11313357121  
4248888336



## No. 70L, Elite Typewriter

### Composition Matrices

This face can be run on any Keyboard arrangement, but must be used on a Keyboard equipped with the typewriter stop.

10 Point No. 70L, Set size .0830"

Mr. Progressive Printer,  
Everywhere.

Dear Sir:

This 10 point No. 70L Elite Typewriter face is designed to fill the demand for a letter which may be used in cases where space must be saved or where it is required to match exactly the typewriter used to fill in the address. It is a hair line face

which is frequently used in printing direct from the type with copying ink, but in fac-simile work the best results are ob-

The regular font contains 98 characters and includes the common fractions and commercial signs in general use.

12345 ABCDEFGHIJKLMNOPQRSTUVWXYZ& 67890\$  
abcdefghijklmnopqrstuvwxyz  
...-:;!?'"+x-%@/n&d#/  
( ) 1 1 1 1 3 3 5 5 7 7 1 1 2 2 -  
4 2 4 8 8 8 8 6 3 3 -

## No. 70L, Remington Typewriter

12 Point No. 70L, Set size .100"

Mr. Progressive Printer.  
Everywhere.

Dear Sir:

This 12 point No. 70L Remington Typewriter face is designed to fill the demand for a letter which may be used on the average class of typewriter work, or where it is required to match exactly the typewriter used to fill in the address. It is a hair line face which is frequently used in printing direct from the type with copying ink, but in fac-simile work the best results are obtained by printing through a ribbon, with an ordinary purple or any kind of

The regular font contains 101 characters and includes the common fractions and commercial signs in general use.

12345 ABCDEFGHIJKLMNOPQRSTUVWXYZ 67890\$  
abcdefghijklmnopqrstuvwxyz  
( ) . , - : ; ! ? ' " + x - % @ / n & d # / ° \* §  
1 1 3 1 3 5 7 1 1 2 -  
4 2 4 8 8 8 8 6 3 3 -

## NON-DISTRIBUTION

Means new type for every job, shorter time taken for make-ready, no time lost in putting old type back into cases, and the possibility of holding the type for any job indefinitely if there is prospect for repeat orders. A profit insurance on your orders and a big selling advantage on repeat orders.

\$1234567890

# No. 170L, Smith Premier Typewriter

## Composition Matrices

This face can be run on any Keyboard arrangement, but must be used on a Keyboard equipped with the typewriter stop.

12 Point No. 170L, Set size .100"

Mr. Progressive Printer.  
Everywhere.

Dear Sir:

This 12 point No. 170L Smith Premier Typewriter face is designed to fill the demand for a letter which may be used on the average class of typewriter work, or where it is required to match exactly the typewriter used to fill in the address. It is a hair line face which is frequently used in printing direct from the type with copying ink, but in fac-simile work the best results are obtained by printing through a ribbon, with an ordinary purple or any kind of copying ink.

There are 10 characters to the inch, the most common set size of all standard typewriters.

There is no limit to the possibilities on fac-simile typewriter work in a printing office supplied with the Monotype faces. Standing matter cost, which would be a considerable item with foundry type, is reduced to the minimum, and, while Monotype type wears, like foundry type, long runs are profitable in the Monotype shop because it is cheaper to recast than distribute.

By running the keyboard ribbon through the caster twice or more, as many forms may be printed at one impression as the press capacity will admit. This saving in extra composition and electrotyping expense is a distinct Monotype advantage on typewriter work.

The regular font contains 101 characters and includes the common fractions and commercial signs in general use.

12345 ABCDEFGHIJKLMNOPQRSTUVWXYZ& 67890\$  
abcdefghijklmnopqrstuvwxyz  
.,-:;!?'"+x-°%&@£/¢#D\*§  
( )  $\frac{1}{4}$   $\frac{1}{2}$   $\frac{3}{4}$   $\frac{5}{8}$   $\frac{7}{8}$   $\frac{1}{2}$  -

# No. 72L, Reproducing Typewriter

## Composition Matrices

This face can be run on any Keyboard arrangement, but must be used on a Keyboard equipped with the typewriter stop.

8 Point No. 72L, Set size .0692

Mr. Progressive Printer,  
Everywhere.

Dear Sir:

This 8 point No. 72L Reproducing Typewriter face is designed to fill the demand for a letter which may be used in cases where space must be saved or where it is not required to match exactly the typewriter used to fill in the address. It is used in printing direct from the type with

The regular font contains 99 characters as follows:

12345 ABCDEFGHIJKLMNOPQRSTUVWXYZ& 67890\$  
abcdefghijklmnopqrstuvwxyz  
.-:;!'?"'#####()~+=x%/#D@%#

10 Point No. 72L, Set size .0830'

Mr. Progressive Printer,  
Everywhere.

Dear Sir:

This 10 point No. 72L Reproducing Typewriter face is designed to fill the demand for a letter which may be used in cases where space must be saved or where it is required to match exactly the typewriter used to fill in the address. It is fre-

The regular font contains 105 characters as follows:

12345 ABCDEFGHIJKLMNOPQRSTUVWXYZ& 67890\$  
abcdefghijklmnopqrstuvwxyz  
.-:;!'?"'#####()~+=°x%/#D@%#±\*\$

12 Point No. 72L, Set size .100'

Mr. Progressive Printer,  
Everywhere.

Dear Sir:

This 12 point No. 72L Reproducing Typewriter face is designed to fill the demand for a letter which may be used on the average class of typewriter work, or where it is required to match exactly the typewriter used to fill in the

The regular font contains 78 characters as follows:

12345 ABCDEFGHIJKLMNOPQRSTUVWXYZ& 67890\$  
abcdefghijklmnopqrstuvwxyz  
().-:;!'?'%#/

# No. 270L, Underwood Typewriter

## Composition Matrices

This face can be run on any Keyboard arrangement, but must be used on a Keyboard equipped with the typewriter stop.

### 10 Point No. 270L, Set Size, .0830"

Mr. Progressive Printer,  
Everywhere.

Dear Sir:

This 10 point No. 270L Underwood Typewriter face is designed to fill the demand for a letter which may be used in cases where space must be saved or where it is required to match exactly the typewriter used to fill in the address. It is a hair line face

which is frequently used in printing direct from the type with copying ink, but in fac-simile work the best results are obtained by printing through a ribbon, with an ordinary purple or any kind of copying ink.

As there are 12 characters to the inch, the saving in space

The regular font contains 86 characters and includes the common fractions and commercial signs in general use.

12345 ABCDEFGHIJKLMNOPQRSTUVWXYZ& 67890\$  
abcdefghijklmnopqrstuvwxyz  
() . , - ; ! ? ' " % @ / \* #  $\frac{1}{2}$   $\frac{1}{4}$   $\frac{3}{4}$

### 12 Point No. 270L, Set Size, .100"

Mr. Progressive Printer,  
Everywhere.

Dear Sir:

This 12 point No. 270L Underwood Typewriter face is designed to fill the demand for a letter which may be used on the average class of typewriter work, or where it is required to match exactly the typewriter used to fill in the address. It is a hair line face which is frequently used in printing direct from the type with copying ink, but in fac-simile work the best results are obtained by printing through a ribbon, with an ordinary purple or any kind of copying ink.

The regular font contains 86 characters and includes the common fractions and commercial signs in general use.

12345 ABCDEFGHIJKLMNOPQRSTUVWXYZ& 67890\$  
abcdefghijklmnopqrstuvwxyz  
() . , - ; ! ? ' " % @ / \* #  $\frac{1}{2}$   $\frac{1}{4}$   $\frac{3}{4}$

# No. 272L, Royal Typewriter

## Composition Matrices

This face can be run on any Keyboard arrangement, but must be used on a Keyboard equipped with the typewriter stop.

10 Point No. 272L, Set Size, .0830"

Mr. Progressive Printer,  
Everywhere.

Dear Sir:

This 10 point No. 272L Royal Typewriter face is designed to fill the demand for a letter which may be used in cases where space must be saved or where it is required to match exactly the typewriter used to fill in the address. It is a hair line face

which is frequently used in printing direct from the type with copying ink, but in fac-simile work the best results are obtained by printing through a ribbon, with an ordinary purple or any kind of copying ink.

As there are 12 characters to the inch, the saving in space

The regular font contains 84 characters and includes the common fractions and commercial signs in general use.

12345 ABCDEFGHIJKLMNOPQRSTUVWXYZ& 67890\$  
abcdefghijklmnopqrstuvwxyz  
.,-:;!?''"\_%\*¢/##<sup>113</sup>/<sub>244</sub>

12 Point No. 272L, Set Size, .100"

Mr. Progressive Printer,  
Everywhere.

Dear Sir:

This 12 point No. 272L Royal Typewriter face is designed to fill the demand for a letter which may be used on the average class of typewriter work, or where it is required to match exactly the typewriter used to fill in the address. It is a hair line face which is frequently used in printing direct from the type with copying ink, but in fac-simile work the best results are obtained by printing through a ribbon, with an ordinary purple or any kind of copying ink.

The regular font contains 84 characters and includes the common fractions and commercial signs in general use.

12345 ABCDEFGHIJKLMNOPQRSTUVWXYZ& 67890\$  
abcdefghijklmnopqrstuvwxyz  
<sup>113</sup>/<sub>244</sub>#,.-:;!?''"¢,%@/\_\*

# No. 370L, Remington Typewriter

## Composition Matrices

This face can be run on any Keyboard arrangement, but must be used on a Keyboard equipped with the typewriter stop.

10 Point No. 370L, Set Size, .0830"

Mr. Progressive Printer,  
Everywhere.

Dear Sir:

This 10 point No. 370L Remington Typewriter underscored face is designed to fill the demand for a letter showing the underscore as produced on the typewriter, and is frequently required to reproduce underscored sections of fac-simile letters composed in the No. 270L series. It is a hair line face which is frequently used in printing direct from the type with copying ink, but in fac-simile work the best results are obtained by printing through a ribbon, with an ordinary purple or any kind of copying ink.

The regular font contains 101 characters and includes the common fractions and commercial signs in general use. These matrices are sold at Class D prices.

12345 ABCDEFGHIJKLMNOPQRSTUVWXYZ& 67890\$  
abcdefghijklmnopqrstuvwxyz  
.,-:;!?"'+x-%@#&#d/()°\$

12 Point No. 370L, Set Size, .100"

Mr. Progressive Printer,  
Everywhere.

Dear Sir:

This 12 point No. 370L Remington Typewriter underscored face is designed to fill the demand for a letter showing the underscore as produced on the typewriter, and is frequently required to reproduce underscored sections of fac-simile letters composed in the No. 270L series. It is a hair line face which is frequently used in printing direct from the type with copying ink, but in fac-simile work the best results are obtained by printing through a ribbon, with an

The regular font contains 101 characters and includes the common fractions and commercial signs in general use. These matrices are sold at class D prices.

12345 ABCDEFGHIJKLMNOPQRSTUVWXYZ& 67890\$  
abcdefghijklmnopqrstuvwxyz  
()., -:;!?"'+x-%@#&#d/#/°\*\$

# No. 95M. Special Arrangement

## Composition Matrices

8 Point No. 95 M, 9 Set

### Monotype Schriftarten

Die beste Art von Originalität ist diejenige, welche sich nach einer gründlichen Lehrzeit fühlbar macht, eine solche, die sich als Vermischung des Begriffes von allem nützlichen und progressiven Streben eines klaren Verstandes erweist. Denn mag ein Mensch noch so tüchtig und originell sein, so muß er dennoch alles, was in seinem Gewerbe oder Beruf früher geschah oder noch gegenwärtig geschieht, hoch schätzen. Wenn die heutigen Buchdrucker nicht als anmaßend angesehen werden wollen, indem sie ihr Gewerbe als eine Kunst darstellen, so müssen sie infolge dessen bereit sein, und auch ihre Bereitwilligkeit zu Tage legen, daselbe solchen Gesetzen zu unterwerfen, durch welche ähnliche Künste so frei wurden. Alle diejenigen, welche die feinen Künste, Wissenschaften und Professionen pflegen, beschäftigen sich mit Geschichte, Literatur und wirklichen Proben der in ihrem Fach liegenden Arbeit. Dennoch findet man diese Umgebung mit all ihren

abcdefghijklmnopqrstubwxyz  
**ABCDEFGHIJKLMN O P Q R S T U V W X Y Z &**  
 \$1234567890  
 ä ö ü ß ã å ç è é ê ë ì í î ï ð ñ ò ó ô õ ö ø ù ú û ü  
 ...;!?'-

10 Point No. 95M, 11 Set

### Monotype Schriftarten

Die beste Art von Originalität ist diejenige, welche sich nach einer gründlichen Lehrzeit fühlbar macht, eine solche, die sich als Vermischung des Begriffes von allem nützlichen und progressiven Streben eines klaren Verstandes erweist. Denn mag ein Mensch noch so tüchtig und originell sein, so muß er dennoch alles, was in seinem Gewerbe oder Beruf früher geschah oder noch gegenwärtig geschieht, hoch schätzen. Wenn die heutigen Buchdrucker nicht als anmaßend angesehen werden wollen, indem sie ihr Gewerbe als eine Kunst darstellen, so müssen sie infolge dessen bereit sein, und ihre Bereitwilligkeit zu Tage legen, daselbe solchen Gesetzen zu unter-

abcdefghijklmnopqrstubwxyz  
**ABCDEFGHIJKLMN O P Q R S T U V W X Y Z &**  
 \$1234567890  
 ä ö ü ß ã å ç è é ê ë ì í î ï ð ñ ò ó ô õ ö ø ù ú û ü  
 ...;!?'-

12 Point No. 95M, 12 1/2 Set

### Monotype Schriftarten

Die beste Art von Originalität ist diejenige, welche sich nach einer gründlichen Lehrzeit fühlbar macht, eine solche, die sich als Vermischung des Begriffes von allem nützlichen und progressiven Streben eines klaren Verstandes erweist. Denn mag ein Mensch noch so tüchtig und originell sein, so muß er dennoch alles, was in seinem Gewerbe oder Beruf früher geschah oder noch gegenwärtig geschieht, hoch schätzen. Wenn die heutigen Buchdrucker nicht als anmaßend angesehen

abcdefghijklmnopqrstubwxyz  
**ABCDEFGHIJKLMN O P Q R S T U V W X Y Z &**  
 \$1234567890  
 ä ö ü ß ã å ç è é ê ë ì í î ï ð ñ ò ó ô õ ö ø ù ú û ü  
 ...;!?'-

### Monotype Schriftarten

Die beste Art von Originalität ist diejenige, welche sich nach einer gründlichen Lehrzeit fühlbar macht, eine solche, die sich als Vermischung des Begriffes von allem nützlichen und progressiven Streben eines klaren Verstandes erweist. Denn mag ein Mensch noch so tüchtig und originell sein, so muß er dennoch alles, was in seinem Gewerbe oder Beruf früher geschah oder noch gegenwärtig geschieht, hoch schätzen. Wenn die heutigen Buchdrucker nicht als anmaßend angesehen werden wollen, indem sie ihr Gewerbe als eine Kunst darstellen, so müssen sie infolge

This series, designated as No. 95M, is made up of our No. 95J series, shown under the classification of Text letters, together with the additional characters necessary to complete the German font. In ordering, specify the proper point size and the series number as above, No. 95M. You will receive characters which are marked 95J, so far as they conform exactly to the No. 95J series, and other characters symbolized H9-95J, which represent the extra characters to complete the German. As this face is on a special arrangement, it requires a special right keybar.



14 Point No. 495

**Frage den Mann, der einen Monotype besitzt  
Er wird sagen, das es alle Arbeit im Setzer-zimmer vollbringt: das keine  
Arbeit zu einfach oder zu schwierig ist um Profit zu bringen  
\$1234567890**

18 Point No. 495

**Man geht nach große Arbeit  
Hat man aber nicht die richtige Ausstattung, so ist Verlust  
unbermeidlich  
\$1234567890**

24 Point No. 495

**Eine Monotype Anlage  
Vollbringt alle Arbeit pünktlich für gewissen und  
zufriedenstellenden Profit  
\$1234567890**

30 Point No. 495

**Die wunderschöne Arbeit der  
Monotype's baut ein Geschäft, welches besser  
ist als niedrige Preise  
\$1234567890**

36 Point No. 495

**Viele Sorten  
befriedigen und helfen den Arbeiter  
\$1234567890**

This series, designated as No. 495, is made up of our No. 95 series, together with the additional characters necessary to complete the German font. In ordering, specify the proper point size and the series number as above, No. 495. You will receive characters which are all marked 95, including the extra characters to complete the German.

**No. 99M. German Arrangement C**

**Composition Matrices**

6 Point No. 99M, 7 Set

**Monotype Schriftarten**

Die beste Art von Originalität ist diejenige, welche sich nach einer gründlichen Lehrzeit fühlbar macht, eine solche, die sich als Vermischung des Begriffes von allem nützlichen und progressiven Streben eines klaren Verstandes erweist. Denn mag ein Mensch noch so tüchtig und originell sein, so muß er dennoch alles, was in seinem Gewerbe oder Beruf früher geschah oder noch gegenwärtig geschieht, hoch schätzen. Wenn die heutigen Buchdrucker nicht als anmaßend angesehen werden wollen, indem sie ihr Gewerbe als eine Kunst darstellen, so müssen sie in Folge dessen bereit sein, und auch ihre Bereitwilligkeit zu Tage legen, daselbe solchen Gesetzen zu unterwerfen, durch welche ähnliche Künste so frei wurden. Alle diejenigen, welche die feinen Künste, Wissenschaften und Professionen pflegen, beschäftigen sich mit Geschichte, Literatur und wirklichen Proben der in ihrem Fach liegenden Arbeit. Dennoch findet man diese Umgebung mit all ihren Eigenschaften in der Buchdruckerei höchst selten. Wirkliche Kunst kann nie in dunkeln Winkeln oder unter Hindernissen oder in Unwissenheit dessen was Talent und Genie errungen haben, blühen. Einem vorausgegangenen Fall richtig folgen heißt nicht eines oder das andere Beispiel slavisch nachahmen, sondern die berühmten Meister gründlich forschen und deren großen Errungenschaften würdigen, durch welche wir in unserem Wissen selbsttendend und selbstherrschend werden und daraus nur den größten Vorteil und Nutzen ziehen können. Der junge eifrige Anfänger, der sich sofort mit neuen fast unmöglichen Ideen abgeben will, findet sich gar zu oft in seinen Ansichten getäuscht und verschwindet bald ganz und gar vom Geschäftsleben, während der bedächtiger und mit größeren Kenntnissen begabte Geschäftsmann wenigstens ebenso viel Zeit in der Vermeidung von Fehlern verwenden wird als in der Ausführung von großartigen und epochemachenden Projekten. Die beste Art von Originalität ist diejenige, welche sich nach einer gründlichen Lehrzeit fühlbar macht, eine solche, die sich als Vermischung des Begriffes von allem nützlichen und progressiven Streben eines klaren Verstandes erweist. Denn mag ein Mensch noch so tüchtig und originell sein, so muß er dennoch

abcdefghijklmnopqrstuvwxyz  
 ABCDEFGHIJKLMNOPQRSTUVWXYZ  
 \$1234567890  
 Ä Ö Ü ä ö ü ß Æ œ Œ Œ ı ¨

8 Point No. 99M, 8 1/2 Set

**Monotype Schriftarten**

Die beste Art von Originalität ist diejenige, welche sich nach einer gründlichen Lehrzeit fühlbar macht, eine solche, die sich als Vermischung des Begriffes von allem nützlichen und progressiven Streben eines klaren Verstandes erweist. Denn mag ein Mensch noch so tüchtig und originell sein, so muß er dennoch alles, was in seinem Gewerbe oder Beruf früher geschah oder noch gegenwärtig geschieht, hoch schätzen. Wenn die heutigen Buchdrucker nicht als anmaßend angesehen werden wollen, indem sie ihr Gewerbe als eine Kunst darstellen, so müssen sie in Folge dessen bereit sein, und auch ihre Bereitwilligkeit zu Tage legen, daselbe solchen Gesetzen zu unterwerfen, durch welche ähnliche Künste so frei wurden. Alle diejenigen, welche die feinen Künste, Wissenschaften und Professionen pflegen, beschäftigen sich mit Geschichte, Literatur und wirklichen Proben der in ihrem Fach liegenden Arbeit. Dennoch findet man diese Umgebung mit all ihren Eigenschaften in der Buchdruckerei höchst selten. Wirkliche Kunst kann nie in dunkeln Winkeln oder unter Hindernissen oder in Unwissenheit dessen was Talent und Genie errungen haben, blühen. Einem vorausgegangenen Fall richtig folgen heißt nicht eines oder das andere Beispiel slavisch nachahmen, sondern die berühmten Meister gründlich forschen und deren großen

abcdefghijklmnopqrstuvwxyz  
 ABCDEFGHIJKLMNOPQRSTUVWXYZ  
 \$1234567890  
 Ä Ö Ü ä ö ü ß Æ œ Œ Œ ı ¨

10 Point No. 99M, 10 Set

**Monotype Schriftarten**

Die beste Art von Originalität ist diejenige, welche sich nach einer gründlichen Lehrzeit fühlbar macht, eine solche, die sich als Vermischung des Begriffes von allem nützlichen und progressiven Streben eines klaren Verstandes erweist. Denn mag ein Mensch noch so tüchtig und originell sein, so muß er dennoch alles, was in seinem Gewerbe oder Beruf früher geschah oder noch gegenwärtig geschieht, hoch schätzen. Wenn die heutigen Buchdrucker nicht als anmaßend angesehen werden wollen, indem sie ihr Gewerbe als eine Kunst darstellen, so müssen sie in Folge dessen bereit sein, und auch ihre Bereitwilligkeit zu Tage legen, daselbe solchen Gesetzen zu unterwerfen, durch welche ähnliche Künste so frei wurden. Alle diejenigen, welche die feinen Künste, Wissenschaften und Professionen pflegen, beschäftigen sich mit Geschichte, Literatur und wirklichen Proben der in ihrem Fach liegenden Arbeit. Dennoch findet man diese Umgebung mit all ihren

abcdefghijklmnopqrstuvwxyz  
 ABCDEFGHIJKLMNOPQRSTUVWXYZ  
 \$1234567890  
 Ä Ö Ü ä ö ü ß Æ œ Œ Œ ı ¨

**Monotype Schriftarten**

Die beste Art von Originalität ist diejenige, welche sich nach einer gründlichen Lehrzeit fühlbar macht, eine solche, die sich als Vermischung des Begriffes von allem nützlichen und progressiven Streben eines klaren Verstandes erweist. Denn mag ein Mensch noch so tüchtig und originell sein, so muß er dennoch alles, was in seinem Gewerbe oder Beruf früher geschah oder noch gegenwärtig geschieht, hoch schätzen. Wenn die heutigen Buchdrucker nicht als anmaßend angesehen werden wollen, indem sie ihr Gewerbe als eine Kunst darstellen, so müssen sie in Folge dessen bereit sein, und auch ihre Bereitwilligkeit zu Tage legen, daselbe solchen Gesetzen zu unterwerfen, durch welche ähnliche Künste so frei wurden. Alle diejenigen, welche die feinen Künste, Wissenschaften und Professionen pflegen, beschäftigen sich mit Geschichte, Literatur und wirklichen Proben der in ihrem Fach liegenden Arbeit. Dennoch findet man diese Umgebung mit all ihren Eigenschaften in der Buchdruckerei höchst selten. Wirkliche Kunst kann nie in dunkeln Winkeln oder unter Hindernissen oder in Unwissenheit dessen was Talent

# No. 99M. German Arrangement C

## Composition Matrices

11 Point No. 99M, 10½ Set

### Monotype Schriftarten

Die beste Art von Originalität ist diejenige, welche sich nach einer gründlichen Lehrzeit fühlbar macht, eine solche, die sich als Vermischung des Begriffes von allem nützlichen und progressiven Streben eines klaren Verstandes erweist. Denn mag ein Mensch noch so tüchtig und originell sein, so muß er dennoch alles, was in seinem Gewerbe oder Beruf früher geschah oder noch gegenwärtig geschieht, hoch schätzen. Wenn die heutigen Buchdrucker nicht als anmaßend angesehen werden wollen, indem sie ihr Gewerbe als eine Kunst darstellen, so müssen sie infolge dessen bereit sein, und ihre Bereitwilligkeit zu Tage legen, dasselbe solchen Gesetzen zu unterwerfen,

### Monotype Schriftarten

Die beste Art von Originalität ist diejenige, welche sich nach einer gründlichen Lehrzeit fühlbar macht, eine solche, die sich als Vermischung des Begriffes von allem nützlichen und progressiven Streben eines klaren Verstandes erweist. Denn mag ein Mensch noch so tüchtig und originell sein, so muß er dennoch alles, was in seinem Gewerbe oder Beruf früher geschah, oder noch gegenwärtig geschieht, hoch schätzen. Wenn die heutigen Buchdrucker nicht als anmaßend angesehen werden wollen, indem sie ihr Gewerbe als eine Kunst darstellen, so müssen sie infolge dessen bereit sein, und ihre Bereitwilligkeit zu Tage legen, dasselbe solchen Gesetzen zu unterwerfen, durch welche ähnliche Künste so frei wurden. Alle diejenigen, welche die feinen Künste, Wissenschaften

abcdefghijklmnopqrstuvwxyz

ABCDEFGHIJKLMN O PQRSTUVWXYZ

\$1234567890

Ä Ö Ü ä ö ü ff ft fi ll lz tz ch ff fl fi zc.

.,;:!?'="")(- — . . . .

12 Point No. 99M, 11½ Set

### Monotype Schriftarten

Die beste Art von Originalität ist diejenige, welche sich nach einer gründlichen Lehrzeit fühlbar macht, eine solche, die sich als Vermischung des Begriffes von allem nützlichen und progressiven Streben eines klaren Verstandes erweist. Denn mag ein Mensch noch so tüchtig und originell sein, so muß er dennoch alles, was in seinem Gewerbe oder Beruf früher geschah oder noch gegenwärtig geschieht, hoch schätzen. Wenn die heutigen Buchdrucker nicht als anmaßend angesehen werden wollen, indem sie ihr Gewerbe als eine Kunst darstellen, so müssen sie infolge dessen bereit sein, und auch ihre Bereitwilligkeit zu Tage legen, dasselbe solchen Gesetzen zu unterwerfen, durch welche ähnliche Künste so frei

### Monotype Schriftarten

Die beste Art von Originalität ist diejenige, welche sich nach einer gründlichen Lehrzeit fühlbar macht, eine solche, die sich als Vermischung des Begriffes von allem nützlichen und progressiven Streben eines klaren Verstandes erweist. Denn mag ein Mensch noch so tüchtig und originell sein, so muß er dennoch alles, was in seinem Gewerbe oder Beruf früher geschah, oder noch gegenwärtig geschieht, hoch schätzen. Wenn die heutigen Buchdrucker nicht als anmaßend angesehen werden wollen, indem sie ihr Gewerbe als eine Kunst darstellen, so müssen sie infolge dessen bereit sein, und auch ihre Bereitwilligkeit zu Tage legen, dasselbe solchen Gesetzen zu unterwerfen, durch welche ähnliche Künste so frei wurden. Alle diejenigen, welche die feinen Künste, Wissenschaften und Professionen pflegen, beschäftigen sich mit Geschichte, Literatur und

abcdefghijklmnopqrstuvwxyz

ABCDEFGHIJKLMN O PQRSTUVWXYZ

\$1234567890

Ä Ö Ü ä ö ü ff ft fi ll lz tz ch ff fl fi zc.

.,;:!?'="")(- — . . . .

No. 100M. German Arrangement C

Composition Matrices

6 Point No. 100M, 7 Set

Monotype Schriftarten

Die beste Art von Originalität ist diejenige, welche sich nach einer gründlichen Lehrzeit fühlbar macht, eine solche, die sich als Vermischung des Begriffes von allem nützlichen und progressiven Streben eines klaren Verstandes erweist. Denn mag ein Mensch noch so tüchtig und originell sein, so muß er dennoch alles, was in seinem Gewerbe oder Beruf früher geschah oder noch gegenwärtig geschieht, hoch schätzen. Wenn die heutigen Buchdrucker nicht als anmaßend angesehen werden wollen, indem sie ihr Gewerbe als eine Kunst darstellen, so müssen sie bereit sein, und auch ihre Bereitwilligkeit zu Tage legen, daselbe Gesehen zu unterwerfen, durch welche ähnliche Künste so frei wurden. Alle diejenigen, welche die feinen Künste, Wissenschaften und Professionen pflegen, beschäftigen sich mit Geschichte, Literatur und wirklichen Proben der in ihrem Fach liegenden Arbeit. Dennoch findet man diese Umgebung mit all ihren Eigenschaften in der Buchdruckerei höchst selten. Wirkliche Kunst kann nie in dunkeln Winkeln oder unter Hindernissen oder in Unwissenheit dessen was Talent und Genie errungen haben, blühen. Einem vorausgegangenen Fall richtig folgen heißt nicht eines oder das andere Beispiel slavisch nachahmen, sondern die berühmten Meister gründlich forschen und deren großen Errungenschaften würdigen, durch welche wir in unserem Wissen selbsttätig und selbstherrlichend werden und daraus nur den größten Vorteil und Nutzen ziehen können. Der junge eifrige Anfänger, der sich sofort mit neuen fast unmöglichen Ideen abgeben will, findet sich gar zu oft in seinen Ansichten getäuscht und verschwindet bald ganz und gar vom Geschäftsleben, während der bedächtiger und mit größerer Kenntnissen begabte Geschäftsman weniger als ebensoviel Zeit in der Vermeidung von Fehlern verwendet wird als in der Ausführung von großartigen und epochemachenden Projekten. Die beste Art von Originalität ist diejenige, welche sich nach einer gründlichen Lehrzeit fühlbar macht, eine solche, die sich als Vermischung des Begriffes von allem nützlichen und progressiven Stre-

abcdefghijklmnopqrstuvwxyz  
ABCDEFGHIJKLMN O PQRSTUVWXYZ  
\$1234567890  
A B C D E F G H I J K L M N O P Q R S T U V W X Y Z  
.,:;!?'="''[] (\* + \$

10 Point No. 100M, 10 Set

Monotype Schriftarten

Die beste Art von Originalität ist diejenige, welche sich nach einer gründlichen Lehrzeit fühlbar macht, eine solche, die sich als Vermischung des Begriffes von allem nützlichen und progressiven Streben eines klaren Verstandes erweist. Denn mag ein Mensch noch so tüchtig und originell sein, so muß er dennoch alles, was in seinem Gewerbe oder Beruf früher geschah oder noch gegenwärtig geschieht, hoch schätzen. Wenn die heutigen Buchdrucker nicht als anmaßend angesehen werden wollen, indem sie ihr Gewerbe als eine Kunst darstellen, so müssen sie infolge dessen bereit sein, und auch ihre Bereitwilligkeit zu Tage legen, daselbe solchen Gesehen zu unterwerfen, durch welche ähnliche Künste so frei wurden. Alle diejenigen, welche die feinen Künste, Wissenschaften und Professionen pflegen, beschäftigen sich mit Geschichte, Literatur und wirklichen Proben der in ihrem Fach liegenden Arbeit. Dennoch findet man diese Umgebung mit all ihren Eigenschaften in der Buchdruckerei höchst selten. Wirkliche Kunst kann nie in

abcdefghijklmnopqrstuvwxyz  
ABCDEFGHIJKLMN O PQRSTUVWXYZ  
\$1234567890  
A B C D E F G H I J K L M N O P Q R S T U V W X Y Z  
.,:;!?'="''[] (\* + \$

8 Point No. 100M, 8 1/2 Set

Monotype Schriftarten

Die beste Art von Originalität ist diejenige, welche sich nach einer gründlichen Lehrzeit fühlbar macht, eine solche, die sich als Vermischung des Begriffes von allem nützlichen und progressiven Streben eines klaren Verstandes erweist. Denn mag ein Mensch noch so tüchtig und originell sein, so muß er dennoch alles, was in seinem Gewerbe oder Beruf früher geschah oder noch gegenwärtig geschieht, hoch schätzen. Wenn die heutigen Buchdrucker nicht als anmaßend angesehen werden wollen, indem sie ihr Gewerbe als eine Kunst darstellen, so müssen sie infolge dessen bereit sein, und auch ihre Bereitwilligkeit zu Tage legen, daselbe solchen Gesehen zu unterwerfen, durch welche ähnliche Künste so frei wurden. Alle diejenigen, welche die feinen Künste, Wissenschaften und Professionen pflegen, beschäftigen sich mit Geschichte, Literatur und wirklichen Proben der in ihrem Fach liegenden Arbeit. Dennoch findet man diese Umgebung mit all ihren Eigenschaften in der Buchdruckerei höchst selten. Wirkliche Kunst kann nie in dunkeln Winkeln oder unter Hindernissen oder in Unwissenheit dessen was Talent und Genie errungen haben, blühen. Einem vorausgegangenen Fall richtig folgen heißt nicht eines oder das andere Beispiel slavisch nachahmen, sondern die berühmten

abcdefghijklmnopqrstuvwxyz  
ABCDEFGHIJKLMN O PQRSTUVWXYZ  
\$1234567890  
A B C D E F G H I J K L M N O P Q R S T U V W X Y Z  
.,:;!?'="''[] (\* + \$

12 Point No. 100M, 11 1/2 Set

Monotype Schriftarten

Die beste Art von Originalität ist diejenige, welche sich nach einer gründlichen Lehrzeit fühlbar macht, eine solche, die sich als Vermischung des Begriffes von allem nützlichen und progressiven Streben eines klaren Verstandes erweist. Denn mag ein Mensch noch so tüchtig und originell sein, so muß er dennoch alles, was in seinem Gewerbe oder Beruf früher geschah oder noch gegenwärtig geschieht, hoch schätzen. Wenn die heutigen Buchdrucker nicht als anmaßend angesehen werden wollen, indem sie ihr Gewerbe als eine Kunst darstellen, so müssen sie infolge dessen bereit sein, und ihre Bereitwilligkeit zu Tage legen, daselbe solchen Gesehen zu unterwerfen, durch welche ähnliche

abcdefghijklmnopqrstuvwxyz  
ABCDEFGHIJKLMN O PQRSTUVWXYZ  
\$1234567890  
A B C D E F G H I J K L M N O P Q R S T U V W X Y Z  
.,:;!?'="''[] (\* + \$

14 Point No. 100

Da ist ein Unterschied  
zwischen dem, was eine Monotype verrichtet, und dem, was andere  
Maschinen verrichten können. Keine andere Maschine macht  
die Hälfte von dem, was diese Maschine verrichtet  
\$1234567890

18 Point No. 100

Unser Verzeichnis wiederholter Bestellungen!  
Von jedem Hundert Monotypes werden Achtunddreißig an  
zufriedenstellte Kunden auf Wiederholungs-  
Bestellungen verkauft  
\$1234567890

24 Point No. 100

Winke mit Bezug auf Monotype-Gießmaschinen!  
Berücksichtigen Sie keine Maschine, die  
nicht einen sichtbaren Vorrat ihrer  
eigenen Matrizen hat!  
\$1234567890

30 Point No. 100

Gießt Schrift schnell!  
Es bezahlt sich besser neue Schrift zu  
gießen, als alte Schrift abzulegen  
\$1234567890

14 Point No. 101

Erspart Ausgaben für Elektrotypieren!  
 Die Monotype wird noch Geld in Ihre eigenen Taschen bringen,  
 außer was Sie an Rechnungen für  
 neue Schrift ersparen  
 \$1234567890

24 Point No. 101

Alle Spatien und Quadraten  
 von 5 Punkt bis 36 Punkt werden auf  
 der Monotype gegossen  
 \$1234567890

30 Point No. 101

60 Ems Pica!  
 Die unvergleichliche Ausdehnung  
 der sehr beschäftigten und  
 gewandten Monotype  
 \$1234567890

36 Point No. 101

Neue Schrift!  
 Was sagen Sie dazu! Nur neue  
 Schrift für jede Arbeit!  
 \$1234567890

# No. 102M. Special Arrangement

## Composition Matrices

6 Point No. 102M, 7½ Set

### Monotype Schriftarten

Die beste Art von Originalität ist diejenige, welche sich nach einer gründlichen Lehrzeit fühlbar macht, eine solche, die sich als Vermischung des Begriffes von allem nützlichen und progressiven Streben eines klaren Verstandes erweist. Denn mag ein Mensch noch so tüchtig und originell sein, so muß er dennoch alles, was in seinem Gewerbe oder Beruf früher geschah oder noch gegenwärtig geschieht, hoch schätzen. Wenn alle die heutigen Buchdrucker nicht als anmaßend angesehen werden wollen, indem sie ihr Gewerbe als eine Kunst darstellen, so müssen sie infolge dessen bereit sein, und auch ihre Bereitwilligkeit, durch welche ähnliche Künste so frei wurden. Alle diejenigen, welche die feinen Künste, Wissenschaften und Professionen pflegen, beschäftigen sich mit Geschichte, Literatur und wirklichen Proben der in ihrem Fach liegenden Arbeit. Dennoch findet man diese Umgebung mit all ihren Eigenschaften in der Buchdruckerei höchst selten. Wirkliche Kunst kann nie in dunkeln Winkeln oder unter Hindernissen oder in Unwissenheit dessen was Talent und Genie errungen haben, blühen. Einem vorausgegangenem Fall richtig folgen heißt nicht eines oder das andere Beispiel slavisch nachahmen, sondern die berühmten Meister gründlich forschen und deren großen Errungenschaften würdigen, durch welche wir in unserem Wissen selbstdenkend und selbstherrschend werden und daraus nur den größten Vorteil und Nutzen ziehen können. Der junge Anfänger, der sich sofort mit neuen fast unmöglichen Ideen abgeben will, findet sich gar zu oft in seinem Ansichten geläufigt und verschwindet bald ganz und gar vom Geschäftsleben, während der bedächtiger und mit größeren Kenntnissen begabte Geschäftsmann wenigstens ebenso viel Zeit in der Vermeidung von Fehlern verwenden wird als in der Ausführung von großartigen und

abcdefghijklmnopqrstuvwxyz  
**ABCDEFGHIJKLMN O P Q R S T U V W X Y Z**  
 \$1234567890  
 ä ö ü ß Æ Å Æ Æ Æ Æ Æ Æ Æ Æ  
 . . . ; ! ? ' -

10 Point No. 102M, 11 Set

### Monotype Schriftarten

Die beste Art von Originalität ist diejenige, welche sich nach einer gründlichen Lehrzeit fühlbar macht, eine solche, die sich als Vermischung des Begriffes von allem nützlichen und progressiven Streben eines klaren Verstandes erweist. Denn mag ein Mensch noch so tüchtig und originell sein, so muß er dennoch alles, was in seinem Gewerbe oder Beruf früher geschah oder noch gegenwärtig geschieht, hoch schätzen. Wenn die heutigen Buchdrucker nicht als anmaßend angesehen werden wollen, indem sie ihr Gewerbe als eine Kunst darstellen, so müssen sie infolge dessen bereit sein, und ihre Bereitwilligkeit zu Tage legen, daselbe solchen Gesetzen zu unter-

abcdefghijklmnopqrstuvwxyz  
**ABCDEFGHIJKLMN O P Q R S T U V W X Y Z**  
 \$1234567890  
 ä ö ü ß Æ Å Æ Æ Æ Æ Æ Æ Æ Æ  
 . . . ; ! ? ' -

8 Point No. 102M, 9 Set

### Monotype Schriftarten

Die beste Art von Originalität ist diejenige, welche sich nach einer gründlichen Lehrzeit fühlbar macht, eine solche, die sich als Vermischung des Begriffes von allem nützlichen und progressiven Streben eines klaren Verstandes erweist. Denn mag ein Mensch noch so tüchtig und originell sein, so muß er dennoch alles, was in seinem Gewerbe oder Beruf früher geschah oder noch gegenwärtig geschieht, hoch schätzen. Wenn die heutigen Buchdrucker nicht als anmaßend angesehen werden wollen, indem sie ihr Gewerbe als eine Kunst darstellen, so müssen sie infolge dessen bereit sein, und auch ihre Bereitwilligkeit zu Tage legen, daselbe solchen Gesetzen zu unterwerfen, durch welche ähnliche Künste so frei wurden. Alle diejenigen, welche die feinen Künste, Wissenschaften und Professionen pflegen, beschäftigen sich mit Geschichte, Literatur und wirklichen Proben der in ihrem Fach liegenden Arbeit. Dennoch findet man diese Umgebung mit all ihren Eigenschaften in der Buchdruckerei höchst selten. Wirkliche Kunst kann nie in dunkeln Winkeln oder unter Hindernissen oder in Unwissenheit dessen was Talent und Genie errungen

abcdefghijklmnopqrstuvwxyz  
**ABCDEFGHIJKLMN O P Q R S T U V W X Y Z**  
 \$1234567890  
 ä ö ü ß Æ Å Æ Æ Æ Æ Æ Æ Æ Æ  
 . . . ; ! ? ' -

12 Point No. 102M, 12½ Set

### Monotype Schriftarten

Die beste Art von Originalität ist diejenige, welche sich nach einer gründlichen Lehrzeit fühlbar macht, eine solche, die sich als Vermischung des Begriffes von allem nützlichen und progressiven Streben eines klaren Verstandes erweist. Denn mag ein Mensch noch so tüchtig und originell sein, so muß er dennoch alles, was in seinem Gewerbe oder Beruf früher geschah oder noch gegenwärtig geschieht, hoch schätzen. Wenn die heutigen Buchdrucker nicht als anmaßend angesehen

abcdefghijklmnopqrstuvwxyz  
**ABCDEFGHIJKLMN O P Q R S T U V W X Y Z**  
 \$1234567890  
 ä ö ü ß Æ Å Æ Æ Æ Æ Æ Æ Æ Æ  
 . . . ; ! ? ' -

This series, designated as No. 102M, is made up of our No. 102J series, shown under the classification of Text letters, together with the additional characters necessary to complete the German font. In ordering, specify the proper point size and the series number as above, No. 102M. You will receive characters which are marked 102J, so far as they conform exactly to the 102J series, and other characters symbolized H9-102J, which represent the extra characters to complete the German. As this face is on a special arrangement, it requires a special right keybar.

14 Point No. 4102

Da ist ein Unterschied  
zwischen dem, was eine Monotype verrichtet, und dem, was andere Maschinen  
verrichten können. Keine andere Maschine macht die Hälfte  
von dem, was diese Maschine verrichtet

\$1234567890

18 Point No. 4102

Unser Verzeichnis wiederholter Bestellungen!  
Von jedem Hundert Monotypen werden Achtunddreißig an  
zufriedengestellte Kunden wieder verkauft

\$1234567890

24 Point No. 4102

Alle Spatien und Quadraten  
von 5 Punkt bis 36 Punkt werden auf der  
Monotype gegossen

\$1234567890

30 Point No. 4102

Gießt Schrift schnell!  
Es bezahlt sich besser neue Schrift zu  
gießen, als alte Schrift abzulegen

\$1234567890

36 Point No. 4102

Was sagen Sie dazu! Nur neue  
Schrift für jede Arbeit!

\$1234567890

This series, designated as No. 4102, is made up of our No. 102 series, together with the additional characters necessary to complete the German font. In ordering, specify the proper point size and the series number as above, No. 4102. You will receive characters which are all marked 102, including the extra characters to complete the German.



# No. 199M. German Arrangement C

## Composition Matrices

6 Point No. 199M, 7½ Set

### Monotype Schriftarten

Die beste Art von Originalität ist diejenige, welche sich nach einer gründlichen Lehrzeit fühlbar macht, eine solche, die sich als Vermischung des Begriffes von allem nützlichen und progressiven Streben eines klaren Verstandes erweist. Denn mag ein Mensch noch so tüchtig und originell sein, so muß er dennoch alles, was in seinem Gewerbe oder Beruf früher geschah oder noch gegenwärtig geschieht, hoch schätzen. Wenn die heutigen Buchdrucker nicht als anmaßend angesehen werden wollen, indem sie ihr Gewerbe als eine Kunst darstellen, so müssen sie bereit sein, und auch ihre Bereitwilligkeit zu Tage legen, dasselbe solchen Gesetzen zu unterwerfen, durch welche ähnliche Künste so frei wurden. Alle diejenigen, welche die feinen Künste, Wissenschaften und Professionen pflegen, beschäftigen sich mit Geschichte, Literatur und wirklichen Proben der in ihrem Fach liegenden Arbeit. Dennoch findet man diese Umgebung mit all ihren Eigenschaften in der Buchdruckerei höchst selten. Wirkliche Kunst kann nie in dunkeln Winkeln oder unter Hindernissen oder in Unwissenheit dessen was Talent und Genie errungen haben, blühen. Einem vorausgegangenen Fall richtig folgen heißt nicht eines oder das andere Beispiel slavisch nachahmen, sondern die berühmten Meister gründlich forschen und deren großen Errungenschaften würdigen, durch welche wir in unserem Wissen selbstdenkend und selbstherrlichend werden und daraus nur den größten Vorteil und Nutzen ziehen können. Der junge eifrige Anfänger, der sich sofort mit neuen fast unmöglichen Ideen abgeben will, findet sich gar zu oft in seinen Ansichten getäuscht und verschwindet bald ganz und gar vom Geschäftsleben während der bedächtigeren und mit größeren Kenntnissen begabte Geschäftsmann wenigstens ebenso viel Zeit in der Vermeidung von Fehlern verwenden wird als in der Ausführung von großartigen und epochemachenden Projekten. Die beste Art von Originalität ist diejenige, welche sich nach einer gründlichen Lehrzeit fühlbar macht, eine solche, die sich als Vermischung

abcdefghijklmnopqrstuvwxyz  
 ABCDEFGHIJKLMNOPQRSTUVWXYZ  
 1234567890  
 a b c d e f g h i j k l m n o p q r s t u v w x y z  
 . . . ; ! ? ' , " . . . . .

8 Point No. 199M, 9½ Set

### Monotype Schriftarten

Die beste Art von Originalität ist diejenige, welche sich nach einer gründlichen Lehrzeit fühlbar macht, eine solche, die sich als Vermischung des Begriffes von allem nützlichen und progressiven Streben eines klaren Verstandes erweist. Denn mag ein Mensch noch so tüchtig und originell sein, so muß er dennoch alles, was in seinem Gewerbe oder Beruf früher geschah oder noch gegenwärtig geschieht, hoch schätzen. Wenn die heutigen Buchdrucker nicht als anmaßend angesehen werden wollen, indem sie ihr Gewerbe als eine Kunst darstellen, so müssen sie infolge dessen bereit sein, und auch ihre Bereitwilligkeit zu Tage legen, dasselbe solchen Gesetzen zu unterwerfen, durch welche ähnliche Künste so frei wurden. Alle diejenigen, welche die feinen Künste, Wissenschaften und Professionen pflegen, beschäftigen sich mit Geschichte, Literatur und wirklichen Proben der in ihrem Fach liegenden Arbeit. Dennoch findet man diese Umgebung mit all ihren Eigenschaften in der Buchdruckerei höchst selten. Wirkliche Kunst kann nie in dunkeln Winkeln oder unter Hindernissen oder in Unwissenheit dessen was Talent und Genie errungen haben, blühen. Einem vorausgegangenen Fall richtig folgen heißt nicht eines oder das andere Beispiel slavisch nachahmen,

abcdefghijklmnopqrstuvwxyz  
 ABCDEFGHIJKLMNOPQRSTUVWXYZ  
 1234567890  
 a b c d e f g h i j k l m n o p q r s t u v w x y z  
 . . . ; ! ? ' , " . . . . .

# No. 200M. German Arrangement C

6 Point No. 200M, 7½ Set

### Monotype Schriftarten

Die beste Art von Originalität ist diejenige, welche sich nach einer gründlichen Lehrzeit fühlbar macht, eine solche, die sich als Vermischung des Begriffes von allem nützlichen und progressiven Streben eines klaren Verstandes erweist. Denn mag ein Mensch noch so tüchtig und originell sein, so muß er dennoch alles, was in seinem Gewerbe oder Beruf früher geschah oder noch gegenwärtig geschieht, hoch schätzen. Wenn die heutigen Buchdrucker nicht als anmaßend angesehen werden wollen, indem sie ihr Gewerbe als eine Kunst darstellen, so müssen sie infolge dessen bereit sein, und auch ihre Bereitwilligkeit zu Tage legen, dasselbe solchen Gesetzen zu unterwerfen, durch welche ähnliche Künste so frei wurden. Alle diejenigen, welche die feinen Künste, Wissenschaften und Professionen pflegen, beschäftigen sich mit Geschichte, Literatur und wirklichen Proben der in ihrem Fach liegenden Arbeit. Dennoch findet man diese Umgebung mit all ihren Eigenschaften in der Buchdruckerei höchst selten. Wirkliche Kunst kann nie in dunkeln Winkeln oder unter Hindernissen oder in Unwissenheit dessen was Talent und Genie errungen haben, blühen. Einem vorausgegangenen Fall richtig folgen heißt nicht eines oder das andere Beispiel slavisch nachahmen, sondern die berühmten Meister gründlich forschen und deren großen Errungenschaften würdigen, durch welche wir in unserem Wissen selbstdenkend und selbstherrlichend werden und daraus nur den größten Vorteil und Nutzen ziehen können. Der junge eifrige Anfänger, der sich sofort mit neuen fast unmöglichen Ideen abgeben will, findet sich gar zu oft in seinen Ansichten getäuscht und verschwindet bald ganz und gar vom Geschäftsleben, während der bedächtigeren und mit größeren Kenntnissen begabte Geschäftsmann wenigstens ebenso viel Zeit in der Vermeidung von Fehlern verwenden wird als in der Ausführung von großartigen und epochemachenden Projekten. Die beste Art von Originalität ist diejenige, welche sich nach einer gründlichen Lehrzeit fühlbar macht, eine solche, die sich als Vermischung des Begriffes von allem nützlichen und progressiven Streben eines

abcdefghijklmnopqrstuvwxyz  
 ABCDEFGHIJKLMNOPQRSTUVWXYZ  
 1234567890  
 a b c d e f g h i j k l m n o p q r s t u v w x y z  
 . . . ; ! ? ' , " . . . . .

8 Point No. 200M, 9½ Set

### Monotype Schriftarten

Die beste Art von Originalität ist diejenige, welche sich nach einer gründlichen Lehrzeit fühlbar macht, eine solche, die sich als Vermischung des Begriffes von allem nützlichen und progressiven Streben eines klaren Verstandes erweist. Denn mag ein Mensch noch so tüchtig und originell sein, so muß er dennoch alles, was in seinem Gewerbe oder Beruf früher geschah oder noch gegenwärtig geschieht, hoch schätzen. Wenn die heutigen Buchdrucker nicht als anmaßend angesehen werden wollen, indem sie ihr Gewerbe als eine Kunst darstellen, so müssen sie infolge dessen bereit sein, und auch ihre Bereitwilligkeit zu Tage legen, dasselbe solchen Gesetzen zu unterwerfen, durch welche ähnliche Künste so frei wurden. Alle diejenigen, welche die feinen Künste, Wissenschaften und Professionen pflegen, beschäftigen sich mit Geschichte, Literatur und wirklichen Proben der in ihrem Fach liegenden Arbeit. Dennoch findet man diese Umgebung mit all ihren Eigenschaften in der Buchdruckerei höchst selten. Wirkliche Kunst kann nie in dunkeln Winkeln oder unter Hindernissen oder in Unwissenheit dessen was Talent und Genie errungen haben, blühen. Einem vorausgegangenen Fall richtig folgen heißt nicht eines oder das andere Beispiel slavisch nachahmen, sondern die berühmten Meister gründlich forschen und

abcdefghijklmnopqrstuvwxyz  
 ABCDEFGHIJKLMNOPQRSTUVWXYZ  
 1234567890  
 a b c d e f g h i j k l m n o p q r s t u v w x y z  
 . . . ; ! ? ' , " . . . . .

# Greek Marking System

**I**N ORDERING Greek characters use the numbers shown to the left of the character in the chart below; thus, if ordering Psi (Ψ) capital letter of 8 point No. 83M Greek Arrangement C1, the order should read "8 point No. 83M, character No. 23." This number would be the same for this character in all Greek Fonts, the only change in ordering would be the point size and the face number; thus, if 12 point No. 155M capital Psi (Ψ) were ordered, the order should read "12 point No. 155M, character No. 23."

| No. | Char. | No. | Char. | No. | Char. | No. | Char. | No. | Char. | No. | Char. | No. | Char. | No. | Char.  | No. | Char. | No. | Char. |
|-----|-------|-----|-------|-----|-------|-----|-------|-----|-------|-----|-------|-----|-------|-----|--------|-----|-------|-----|-------|
| 1   | A     | 42  | σ     | 83  | ε     | 124 | δ     | 165 | ω     | 206 | φ     | 247 | φ     | 288 | Inv.   | 328 | Ϸ     |     |       |
| 2   | B     | 43  | τ     | 84  | ε     | 125 | δ     | 166 | ω     | 207 | φ     | 248 | φ     | 289 | period | 329 | Ϸ     |     |       |
| 3   | Γ     | 44  | υ     | 85  | ε     | 126 | δ     | 167 | ω     | 208 | φ     | 249 | φ     | 290 | φ      | 330 | Ϸ     |     |       |
| 4   | Δ     | 45  | φ     | 86  | ε     | 127 | δ     | 168 | ω     | 209 | φ     | 250 | φ     | 291 | φ      | 331 | Ϸ     |     |       |
| 5   | E     | 46  | χ     | 87  | ε     | 128 | δ     | 169 | ω     | 210 | φ     | 251 | φ     | 292 | φ      | 332 | Ϸ     |     |       |
| 6   | Z     | 47  | ψ     | 88  | η     | 129 | δ     | 170 | ω     | 211 | φ     | 252 | φ     | 293 | φ      | 333 | Ϸ     |     |       |
| 7   | H     | 48  | ω     | 89  | η     | 130 | δ     | 171 | ω     | 212 | φ     | 253 | φ     | 294 | φ      | 334 | Ϸ     |     |       |
| 8   | Θ     | 49  | α     | 90  | η     | 131 | δ     | 172 | ω     | 213 | φ     | 254 | φ     | 295 | φ      | 335 | Ϸ     |     |       |
| 9   | I     | 50  | θ     | 91  | η     | 132 | δ     | 173 | ω     | 214 | φ     | 255 | φ     | 296 | φ      | 336 | Ϸ     |     |       |
| 10  | K     | 51  | φ     | 92  | η     | 133 | δ     | 174 | ω     | 215 | φ     | 256 | φ     | 297 | φ      | 337 | Ϸ     |     |       |
| 11  | Λ     | 52  | s     | 93  | η     | 134 | δ     | 175 | ω     | 216 | φ     | 257 | φ     | 298 | φ      | 338 | Ϸ     |     |       |
| 12  | M     | 53  | σ     | 94  | η     | 135 | δ     | 176 | ω     | 217 | φ     | 258 | φ     | 299 | φ      | 339 | Ϸ     |     |       |
| 13  | N     | 54  | x     | 95  | η     | 136 | δ     | 177 | ω     | 218 | φ     | 259 | φ     | 300 | φ      | 340 | Ϸ     |     |       |
| 14  | Ξ     | 55  | f     | 96  | η     | 137 | δ     | 178 | ω     | 219 | φ     | 260 | φ     | 301 | φ      | 341 | Ϸ     |     |       |
| 15  | O     | 56  | θ     | 97  | η     | 138 | δ     | 179 | ω     | 220 | φ     | 261 | φ     | 302 | φ      | 342 | Ϸ     |     |       |
| 16  | Π     | 57  | θ     | 98  | η     | 139 | δ     | 180 | ω     | 221 | φ     | 262 | φ     | 303 | φ      | 343 | Ϸ     |     |       |
| 17  | P     | 58  |       | 99  | η     | 140 | δ     | 181 | ω     | 222 | φ     | 263 | φ     | 304 | φ      | 344 | Ϸ     |     |       |
| 18  | Σ     | 59  | z     | 100 | η     | 141 | δ     | 182 | ω     | 223 | φ     | 264 | φ     | 305 | φ      | 345 | Ϸ     |     |       |
| 19  | T     | 60  | á     | 101 | η     | 142 | δ     | 183 | ω     | 224 | φ     | 265 | φ     | 306 | φ      | 346 | Ϸ     |     |       |
| 20  | T     | 61  | á     | 102 | η     | 143 | δ     | 184 | ω     | 225 | φ     | 266 | φ     | 307 | φ      | 347 | Ϸ     |     |       |
| 21  | Φ     | 62  | á     | 103 | η     | 144 | δ     | 185 | ω     | 226 | φ     | 267 | φ     | 308 | φ      | 348 | Ϸ     |     |       |
| 22  | X     | 63  | á     | 104 | η     | 145 | δ     | 186 | ω     | 227 | φ     | 268 | φ     | 309 | φ      | 349 | Ϸ     |     |       |
| 23  | Ψ     | 64  | á     | 105 | η     | 146 | δ     | 187 | ω     | 228 | φ     | 269 | φ     | 310 | φ      | 350 | Ϸ     |     |       |
| 24  | Ω     | 65  | á     | 106 | η     | 147 | δ     | 188 | ω     | 229 | φ     | 270 | φ     | 311 | φ      | 351 | Ϸ     |     |       |
| 25  | α     | 66  | á     | 107 | η     | 148 | δ     | 189 | ω     | 230 | φ     | 271 | φ     | 312 | φ      | 352 | Ϸ     |     |       |
| 26  | β     | 67  | á     | 108 | η     | 149 | δ     | 190 | ω     | 231 | φ     | 272 | φ     | 313 | φ      | 353 | Ϸ     |     |       |
| 27  | γ     | 68  | á     | 109 | η     | 150 | δ     | 191 | ω     | 232 | φ     | 273 | φ     | 314 | φ      | 354 | Ϸ     |     |       |
| 28  | δ     | 69  | á     | 110 | η     | 151 | δ     | 192 | ω     | 233 | φ     | 274 | φ     | 315 | φ      | 355 | Ϸ     |     |       |
| 29  | ε     | 70  | á     | 111 | η     | 152 | δ     | 193 | ω     | 234 | φ     | 275 | φ     | 316 | φ      | 356 | Ϸ     |     |       |
| 30  | ζ     | 71  | á     | 112 | η     | 153 | δ     | 194 | ω     | 235 | φ     | 276 | φ     | 317 | φ      | 357 | Ϸ     |     |       |
| 31  | η     | 72  | á     | 113 | η     | 154 | δ     | 195 | ω     | 236 | φ     | 277 | φ     | 318 | φ      | 358 | Ϸ     |     |       |
| 32  | θ     | 73  | á     | 114 | η     | 155 | δ     | 196 | ω     | 237 | φ     | 278 | φ     | 319 | φ      | 359 | Ϸ     |     |       |
| 33  | ι     | 74  | á     | 115 | η     | 156 | δ     | 197 | ω     | 238 | φ     | 279 | φ     | 320 | φ      | 360 | Ϸ     |     |       |
| 34  | κ     | 75  | á     | 116 | η     | 157 | δ     | 198 | ω     | 239 | φ     | 280 | φ     | 321 | φ      | 361 | Ϸ     |     |       |
| 35  | λ     | 76  | á     | 117 | η     | 158 | δ     | 199 | ω     | 240 | φ     | 281 | φ     | 322 | φ      | 362 | Ϸ     |     |       |
| 36  | μ     | 77  | á     | 118 | η     | 159 | δ     | 200 | ω     | 241 | φ     | 282 | φ     | 323 | φ      | 363 | Ϸ     |     |       |
| 37  | ν     | 78  | á     | 119 | η     | 160 | δ     | 201 | ω     | 242 | φ     | 283 | φ     | 324 | φ      | 364 | Ϸ     |     |       |
| 38  | ξ     | 79  | á     | 120 | η     | 161 | δ     | 202 | ω     | 243 | φ     | 284 | φ     | 325 | φ      | 365 | Ϸ     |     |       |
| 39  | ο     | 80  | á     | 121 | η     | 162 | δ     | 203 | ω     | 244 | φ     | 285 | φ     | 326 | φ      | 366 | Ϸ     |     |       |
| 40  | π     | 81  | á     | 122 | η     | 163 | δ     | 204 | ω     | 245 | φ     | 286 | φ     | 327 | φ      | 367 | Ϸ     |     |       |
| 41  | ρ     | 82  | á     | 123 | η     | 164 | δ     | 205 | ω     | 246 | φ     | 287 | φ     |     |        |     |       |     |       |









# Greek Display Faces

**T**HE Greek fonts shown below are sold at class A prices for single Matrices. The English characters necessary to complete the Greek alphabet for any of these fonts are also sold at class A prices for single Matrices.

How and what to order: If ordering 18 point 108S Greek, also order the fourteen English characters of 18 point 108 series necessary to complete the alphabet. When ordering Greek characters, always specify the character number as well as point size and series number.

The English Matrices can be had through the Matrix Library, by renting the full font of the series wanted.

Greek alphabet showing the 14 English characters as noted above. 18 point 108S Greek and 18 point 108 Series.

Α Β Γ Δ Ε Ζ Η Θ Ι Κ Λ Μ Ν Ξ Ο Π Ρ Σ Τ Υ Φ Χ Ψ Ω

14 Point 63S Greek, to complete Alphabet order 14 Point 63 Series.

Γ Δ Θ Λ Ξ Π Σ Φ Ψ Ω

18 Point 50S Greek, to complete Alphabet order 18 Point 50 Series.

Γ Δ Θ Λ Ξ Π Σ Φ Ψ Ω

18 Point 111S Greek, to complete Alphabet order 18 Point 111 Series.

Γ Δ Θ Λ Ξ Π Σ Φ Ψ Ω

18 Point 121S Greek, to complete Alphabet order 18 Point 121 Series.

Γ Δ Θ Λ Ξ Π Σ Φ Ψ Ω

24 Point 62S Greek, to complete Alphabet order 24 Point 62 Series.

Γ Δ Θ Λ Ξ Π Σ Φ Ψ Ω

24 Point 94S Greek, to complete Alphabet order 24 Point 94 Series.

Γ Δ Θ Λ Ξ Π Σ Φ Ψ Ω

30 point 37S Greek, to complete alphabet order 30 point 37 Series.

Γ Δ Θ Λ Ξ Π Σ Φ Ψ Ω

30 Point 111S Greek, to complete Alphabet order 30 Point 111 Series.

Γ Δ Θ Λ Ξ Π Σ Φ Ψ Ω

36 Point 89S Greek, to complete Alphabet order 36 Point 89 Series.

Γ Δ Θ Λ Ξ Π Σ Φ Ψ Ω

36 Point 94S Greek, to complete Alphabet order 36 Point 94 Series.

Γ Δ Θ Λ Ξ Π Σ Φ Ψ Ω

36 Point 107S Greek, to complete Alphabet order 36 Point 107 Series.

Γ Δ Θ Λ Ξ Π Σ Φ Ψ Ω

# No. 308A. Ruthenian Arrangement

## Composition Matrices

8 Point No. 308A, 8½ Set

### ЧЕРЕНКИ, РОБЛЕНІ НА MONOTYPE

В останніх часах друкарство розвинулось до кульмінаційної точки. Воно майже не подібне до первісного, коли його винайдено. Все змінилось. Давніші нерівні та незручно вироблені черенки заступили модерні крої черенок та тисячі родів всіляких прикрас. Повільні ручні праси друкарські, на яких можна було видрукувати на годину при великій накладі праці найвище 50 примірників, заступили найновіші поспішні друкарські преси, т. з. ротаційні, які друкують 8—10 тисяч примірників газет чи книжок на годину і то вже готових, зложених. Ручну працю складачів, особливо *бу би без друкарства неможливий. Всі пізніші винаходи мали в друкарстві великого приятеля, яке їх так сказатиб рекламувало, поширювало. Без него вони*

абвгдежзийїіклмнопрстуфхццщьяює  
**АБВГДЕЖЗИЙІІКЛМНОПРСТУ**  
**УФХЦЦШЩЬЯЮЄ**  
 1234567890

абвгдежзийїіклмнопрстуфхццщьяює  
**АБВГДЕЖЗИЙІІКЛМНОПРСТУ**  
**УФХЦЦШЩЬЯЮЄ**  
 1234567890

10 Point No. 308A, 10 Set

### ЧЕРЕНКИ, РОБЛЕНІ НА MONOTYPE

В останніх часах друкарство розвинулось до кульмінаційної точки. Воно майже не подібне до первісного, коли його винайдено. Все змінилось. Давніші нерівні та незручно вироблені черенки заступили модерні крої черенок та тисячі родів всіляких прикрас. Повільні ручні праси друкарські, на яких можна було видрукувати на годину при великій накладі праці *в значній мірі тяжку друкарську працю і збільшили значно її продукцію. Книжка та газета стала нині приступною для кожного.*

абвгдежзийїіклмнопрстуфхццщьяює  
**АБВГДЕЖЗИЙІІКЛМНОПРСТУ**  
**УФХЦЦШЩЬЯЮЄ**  
 1234567890

абвгдежзийїіклмнопрстуфхццщьяює  
**АБВГДЕЖЗИЙІІКЛМНОПРСТУ**  
**УФХЦЦШЩЬЯЮЄ**  
 1234567890

12 Point No. 308A, 12 Set

### ЧЕРЕНКИ, РОБЛЕНІ НА MONOTYPE

В останніх часах друкарство розвинулось до кульмінаційної точки. Давні повільні ручні праси друкарські, на яких можна було видрукувати на годину при великій накладі праці найвище 50 примірників, заступили *найпомітніші прибори друкарські улекшили в значній мірі тяжку друкарську працю і збільшили в значній мірі її про-*

абвгдежзийїіклмнопрстуфхццщьяює  
**АБВГДЕЖЗИЙІІКЛМНОПРСТУФХЦЦШЩЬЯЮЄ**  
 1234567890

абвгдежзийїіклмнопрстуфхццщьяює  
**АБВГДЕЖЗИЙІІКЛМНОПРСТУФХЦЦШЩЬЯЮЄ**  
 1234567890

### ЧЕРЕНКИ, РОБЛЕНІ НА MONOTYPE

В останніх часах друкарство розвинулось до кульмінаційної точки. Давні повільні ручні праси друкарські, на яких можна було видрукувати на годину при великій накладі праці найвище 50 примірників, заступили найновіші поспішні друкарські преси, т. з. ротаційні, які друкують 8—10 тисяч примірників газет чи книжок на годину і то вже готових, зложених.

This series, designated No. 308A, is made up of our No. 8A series, together with the additional characters necessary to complete the Ruthenian font. In ordering, specify the proper point size and the series number as above, No. 308A. You will receive characters which are marked 8A (8C for Italic), so far as they conform exactly to the No. 8A series, and other characters symbolized 308A (308C for Italic), which represent the extra characters to complete the Ruthenian. The Ruthenian arrangement differs from the Russian arrangement in only six characters. In order to set Russian, the necessary characters would be added to a Ruthenian font. This is a special arrangement and requires special left and right keybars, together with stopbars and wedge.



14 Point No. 311

**ВЕЛИКА БЕЗ ПОРІВНЯНЯ РІЖНИЦЯ**  
 між сим, що робить машина „Монотайп“ а сим, що інші  
 машини можуть зробити.

Посідаючи сю машину, має ся все сьвіжі припаси своїх  
 власних черенок і всяких друкарських прикрас.

Сї машини, з огляду на свою практичність, найшли  
 в сьвіті загальне примінене

**\$1234567890**

24 Point No. 311

**ЛІПШЕ МАТИ МАШИНУ,**  
 яка обслужить всякі друкарські роботи  
 скоро і гарно, а кромі сего на кожде  
 бажане зробить довільну скількість  
 нових черенок чи обвідок.

**\$1234567890**

36 Point No. 311

**МОНОТАЙП**  
 се одинока машина, яка  
 побіч своєї звичайної  
 праці вирабляє черенки  
**\$1234567890**

This series, designated as No. 311, is made up of our No. 11 series, together with the additional characters necessary to complete the Ruthenian font. In ordering, specify the proper point size and the series number as above, No. 311. You will receive characters which are marked No. 11, so far as they exactly conform to the No. 11 series, and other characters symbolized No. 311, which represent the extra characters to complete the Ruthenian. The Ruthenian arrangement differs from the Russian arrangement in only six characters. In order to set Russian, the necessary characters would be added to a Ruthenian font.

# No. 318J. Ruthenian Arrangement

## Composition Matrices

8 Point No. 318J, 8½ set

### ЧЕРЕНКИ, РОБЛЕНІ НА MONOTYPE.

В останніх часах друкарство розвинулось до кульмінаційної точки. Воно майже не подібне до первісного, коли його винайдено. Все змінилось. Давніші нерівні та незручно вироблені черенки заступили модерні крої черенок та тисячі родів всіляких прикрас. Повільні ручні праси друкарські, на яких можна було видрукувати на годину при великій накладі праці найвище 50 примірників, заступили найновіші поспішні друкарські преси, т. з. ротаційні, які друкують 8—10 тисяч примірників газет чи книжок на годину і то вже готових, зложених. Ручну працю складачів, особливо при наборі часописів і книжок заступили машини до складання »Monotype«. Інші помічнічі прибори друкарські улекшили в значній мірі тяжку друкарську працю і збільшили значно її продукцію. Книжка та газета стала нині приступною для кожного. Що більше, книжка та газета стала в теперішніх часах майже

абвгдежзийїіклмнопрстуфхцчшщьюяє  
АБВГДЕЖЗИЙІІКЛМНОПРСТ  
УФХЦЧШЩЬЮЯЄ  
12345678905

10 Point No. 318J, 10 set

### ЧЕРЕНКИ, РОБЛЕНІ НА MONOTYPE.

В останніх часах друкарство розвинулось до кульмінаційної точки. Воно майже не подібне до первісного, коли його винайдено. Все змінилось. Давніші нерівні та незручно вироблені черенки заступили модерні крої черенок та тисячі родів всіляких прикрас. Повільні ручні праси друкарські, на яких можна було видрукувати на годину при великій накладі праці найвище 50 примірників, заступили найновішу поспішні друкарські преси, т. з. ротаційні, які друкують 8—10 тисяч примірників газет чи книжок на годину і то вже готових, зложених. Ручну працю складачів, особливо при наборі часописів і книжок засту-

абвгдежзийїіклмнопрстуфхцчшщьюяє  
АБВГДЕЖЗИЙІІКЛМНОПРСТ  
УФХЦЧШЩЬЮЯЄ  
1234567890

12 Point No. 318J, 12 set

### ЧЕРЕНКИ, РОБЛЕНІ НА MONOTYPE.

В останніх часах друкарство розвинулось до кульмінаційної точки. Давні повільні ручні праси друкарські, на яких можна було видрукувати на годину при великій накладі праці найвище 50 примірників, заступили найновіші поспішні друкарські преси, т. з. ротаційні, які друкують 8—10 тисяч примірників газет чи книжок на годину і то вже готових, зложених. Ручну працю складачів, особливо при наборі часописів і книжок заступили машини

абвгдежзийїіклмнопрстуфхцчшщьюяє  
АБВГДЕЖЗИЙІІКЛМНОПРСТУФХЦЧШЩЬЮЯЄ  
1234567890

### ЧЕРЕНКИ, РОБЛЕНІ НА MONOTYPE.

В останніх часах друкарство розвинулось до кульмінаційної точки. Давні новільні ручні праси друкарські, на яких можна було видрукувати на годину при великій накладі праці найвище 50 примірників, заступили найновіші поспішні друкарські преси, т. з. ротаційні, які друкують 8—10 тисяч примірників газет чи книжок на годину і то вже готових, зложених. Ручну працю складачів, особливо при наборі часописів і книжок заступили машини до складання »Monotype«. Інші помічнічі прибори друкарські улекшили в

This series, designated No. 318J, is made up of our No. 118J series, together with the additional characters necessary to complete the Ruthenian font. In ordering, specify the proper point size and the series number as above, No. 318J. You will receive characters which are marked 118J, so far as they conform exactly to the No. 118J series, and other characters symbolized 318J, which represent the extra characters to complete the Ruthenian. The Ruthenian arrangement differs from the Russian arrangement in only six characters. In order to set Russian, the necessary characters would be added to a Ruthenian font. This is a special arrangement and requires a special right keybar when used in combination with the No. 308A Roman.

# → Arrows ←

**T**HE Century Dictionary defines "Arrow" as follows: "A slender, generally pointed, missile weapon made to be shot from a bow." But we, of the twentieth century, make use of the arrow to direct attention to some point in advertising or other reading matter which we think should be emphasized. When used in connection with some particular phrase or paragraph, they rivet the attention in a manner that is prompt and forceful. Many stunts can be quickly formed with the different combinations, to be used in a variety of ways, both as borders and pointers, and the shrewd printer will find numerous instances for its profitable application.

- Class Five Point**  
 D ||||| : 5Yb-476X
- Five and One-half Point**  
 A >>>> > 5XU-1379X
- Six Point**  
 A >>>>>> → 6S-1307X  
 A <<<<<< ← 6Xa-610X  
 A >>>>>> → 6Xa-601X  
 A >>>>>> → 6Y-20X  
 A >>>>>> → 6X-764X  
 A >>>>>> → 6X-765X  
 A >>>>>> → 6X-766X  
 The above three run together  
 >>>>>> →
- A >>>>>> → 6X-20X  
 C AAAAAAAAA A 6Y-43X  
 C UUUUUUU U 6Y-44X  
 C ||||| | 6Y-48Pb  
 C AAAAAAAAA A 6Y-45X  
 The above four run together  
 >>>>>> →
- D ||||| : 6-1064X  
 D ++++++ + 6Wb-707XJ  
 D ||||| | 6Y-169X  
 D ||||| | 6X-570Xl  
 D >>>>>> > 6X-988X  
 D ↑↑↑↑↑ ↑ 6X-920X  
 D ↑↑↑↑↑ ↑ 6X-567X
- Eight Point**  
 A >>>>>> → 8W-20X  
 A <<<<<< ← 8W-174X  
 A >>>>>> → 8W-601X  
 A >>>>>> → 8Wb-1329X  
 D >>>>>> → 8W-350Xl

12-740RL

12-740RL

Class A    Class A    Class A    Class A

24 Pt    30 Pt    24 Pt    24 Pt

515    513    509    508

6-95FL    6-95RL

6-95RL

6-95RL

Class A    Class A    Class A    Class A

24 Pt    24 Pt    12 Pt    12 Pt

504    505    503N    502N

Class A    Class A    Class A    Class A    Class A    Class A

24 Pt    24 Pt    30 Pt    24 Pt    30 Pt    30 Pt

506    507    512    514    511    510

12-point 502N, 12-point 503N, 24-point 504 and 505, 24-point 506, 24-point 507, 24-point 514, 30-point 510, 30-point 511, 30-point 512, match 6-point 95RL rule.

24-point 508 and 509, 24-point 515, 30-point 513, match 12-point 740RL rule.

**Weather Signs**

These are special matrices and have been used as weather signs; prices will be quoted on request.

|         |          |           |
|---------|----------|-----------|
| 6X-528X | 8S-939X  | 10U-565X  |
| 6X-508X | 8Wb-957X | 10U-566X  |
| 7X-322X | 8Wb-958X | 10U-819X  |
| 7X-323X | 10U-21X  | 10U-821X  |
| 8W-21X  | 10U-389X | 10U-824X  |
| 8W-389X | 10U-455X | 10U-825X  |
| 8W-565X | 10U-459X | 11S-1028X |
| 8W-566X |          |           |

- Class Eight Point**  
 D ↓↓↓↓↓↓↓ ↓ 8Wb-1528X  
 D ↑↑↑↑↑↑↑ ↑ 8Wb-1529X  
 D ||||| | 8Wb-570X  
 D >>>>>> > 8Wb-988X  
 D >>>>>> → 8Wb-959X  
 D ↑↑↑↑↑ ↑ 8Wb-920X  
 D >>>>>> → 8Wb-579X
- Ten Point**  
 A >>>>>> → 10U-1138X  
 A >>>>>> → 10U-20X  
 A <<<<<< ← 10U-174X  
 A >>>>>> → 10U-1305X  
 A >>>>>> → 10U-823X  
 D ||||| | 10U-570X  
 D ↑↑↑↑↑↑↑ ↑ 10U-587X  
 D >>>>>> > 10U-410X
- Electro-Display Matrices**  
 A >>>> >>>> 12x18-201X  
 A >>>> >>>> 12x18-1499X  
 A >>>> >>>> 12x18-1500X  
 The above three run together  
 >>>> >>>>
- A >>>> >>>> 18-201X  
 A >>>> >>>> 24-683X  
 A >>>> >>>> 24X-478X  
 D >>>> >>>> 24-14X  
 D >>>> >>>> 36-14X  
 A >>>> >>>> 36-1165X

The above matrices are sold at the single matrix rate of the class indicated; matrices not having the class marked are special and prices will be quoted on request; matrices above 12 point are Electro-Display Matrices

## MONOTYPE INITIALS

36 Point



**F**OR illumination and embellishment of their writings on papyrus the early Egyptians used both the initial and ribbon border effects. Originally the initial was of the same size as the balance of the writing, being distinguished only by the color.

**I**N the eighth century the size of the initial had increased to such an extent that it covered almost one-third of the page. From that time on it decreased in size and embellishment till it reached its present-day form, and, carefully used, has become an aid in preserving an effect of balance on the printed page.

**T**HE evolution of the Monotype from a machine for the setting of type in justified straight lines to one that will cast types of the class most necessary for the production of the finest kind of printing, without impairing its composition production, is one of the greatest achievements of the day.

The Initial Matrices shown on this page are extra price, class B for either color. Matrices for the initials are symbolized No. 126; for the color blocks No. 126a. They are not included in the Library and Will Not be Leased.





### THE BEATEN PATH

**I**S too frequently the path of the beaten. It usually leads in the printing business to mediocrity, indifference, failure.

**T**HE successful printer avoids the beaten path of price-competition and goes after quality, because it is the only kind of printing that pays and keeps on paying.

**H**E is the man who uses the Monotype because it produces quality printing, and fetches the quality price.

**W**HEREVER you find the successful printer, you will also find the versatile Monotype, turning out its share of the work.

**N**OT many printers began using the Monotype in a large way. Most of them began small, and found the very best way to grow was with the assistance of the Monotype.

**A**S a first aid to the man who is trying to avoid the beaten path, and to build up his business in the proper way, the Monotype stands in a class all its own.

**O**VER 9000 Monotypes in actual use, and every owner is a "booster" for the machine and its superiority over every other kind. Let us furnish you with the experience of other printers—together with facts and figures of just what the Monotype will do for you.

SPECIMENS of  
MONOTYPE RULE  
*and* CORNER PIECE  
MATRICES

The Rule Matrices shown on the following pages are made for use with the Continuous Strip Lead and Rule Molds. The Corner Pieces to match the Rule Matrices are made to be cast on the regular Monotype Molds

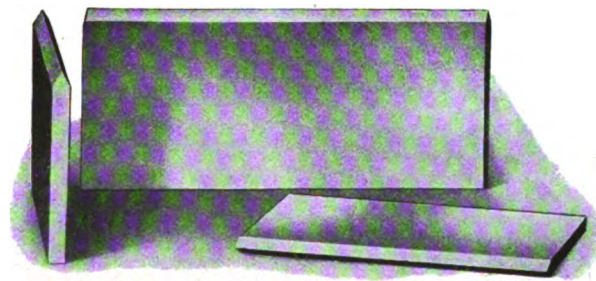

MONOTYPE COLUMN RULE

Every newspaper office should have a special six-point Column Rule Mold, which casts column rules from a matrix that matches the 20RL series, as well as standard rule from any of the six-point matrices shown on the following pages. The column rule cast with this mold has exactly the same cross-section as brass rule, that is, with a bevel extending to edge of body, as shown above.

Depth of matrix drive, .065 inch.

COPYRIGHT, 1917  
BY  
LANSTON MONOTYPE  
MACHINE COMPANY

TRADE MARK  
**MONOTYPE**  
Reg. U. S. Pat. Off.

# Monotype Rules

## Matrices for Continuous Lead and Rule Molds

### 6-Point



*Note:* These Rule Matrices are not interchangeable for different point-size Molds; for example, any two-point Rule Matrix can be used with any two-point Rule Mold, but a two-point Matrix cannot be used with the six-point Rule Mold.



# Monotype Corner Pieces

## Matching Monotype Rules made on Continuous Lead and Rule Molds

### 12-Point Composition Corner Pieces to Match 6-Point Lead and Rule Matrices



12LR-4225N to match 4225RL



12LR-4245N to match 4245RL

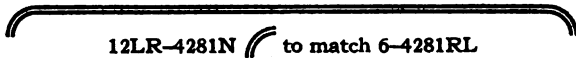

12LR-4281N to match 6-4281RL

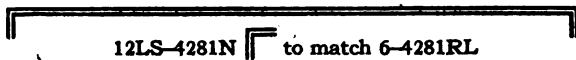

12LS-4281N to match 6-4281RL

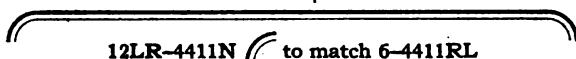

12LR-4411N to match 6-4411RL

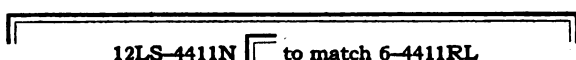

12LS-4411N to match 6-4411RL



12LR-448N to match 6-448RL

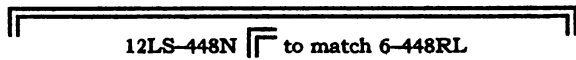

12LS-448N to match 6-448RL



12LR-4481N to match 6-4481RL

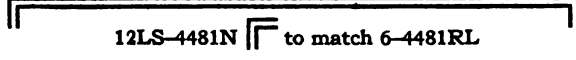

12LS-4481N to match 6-4481RL

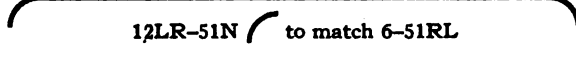

12LR-51N to match 6-51RL

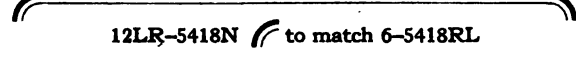

12LR-5418N to match 6-5418RL

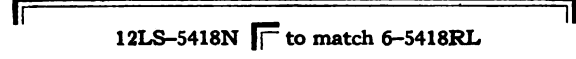

12LS-5418N to match 6-5418RL



12LR-581N to match 6-581RL

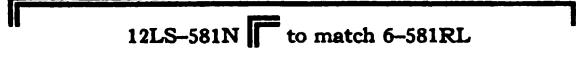

12LS-581N to match 6-581RL

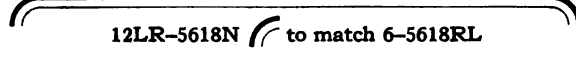

12LR-5618N to match 6-5618RL

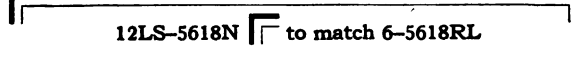

12LS-5618N to match 6-5618RL

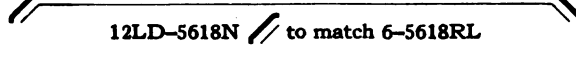

12LD-5618N to match 6-5618RL



12LR-60N to match 6-60RL

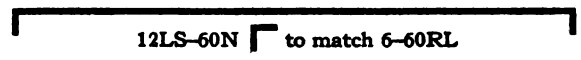

12LS-60N to match 6-60RL

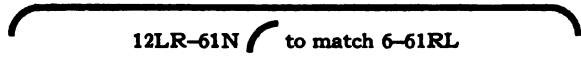

12LR-61N to match 6-61RL

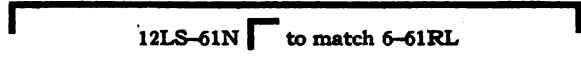

12LS-61N to match 6-61RL

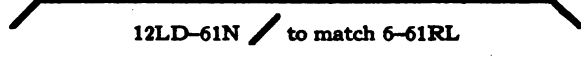

12LD-61N to match 6-61RL



12LR-68N to match 6-68RL



12LS-68N to match 6-68RL

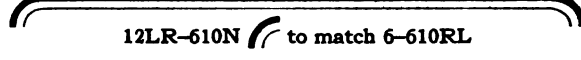

12LR-610N to match 6-610RL

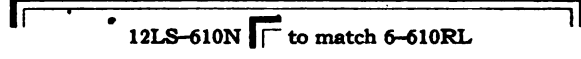

12LS-610N to match 6-610RL



12LR-648N to match 6-648RL



12LS-648N to match 6-648RL



12LR-6468N to match 6-6468RL



12LS-6468N to match 6-6468RL



12LR-80N to match 6-80RL



12LS-80N to match 6-80RL



12LR-81N to match 6-81RL



12LS-81N to match 6-81RL



12LD-81N to match 6-81RL

## Monotype Corner Pieces

### Matching Monotype Rules made on Continuous Lead and Rule Molds

#### 12-Point Composition Corner Pieces to Match 6-Point Lead and Rule Matrices

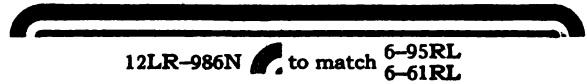
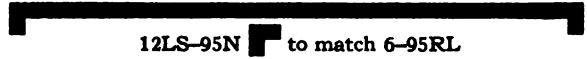
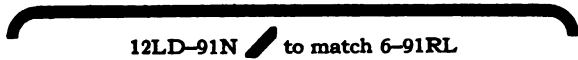
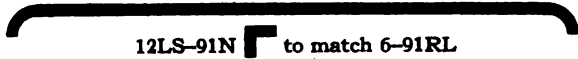
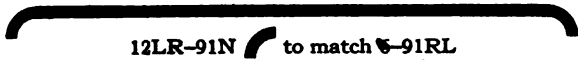

#### 12-Point Composition Corner Pieces to Match 2-Point Lead and Rule Matrices

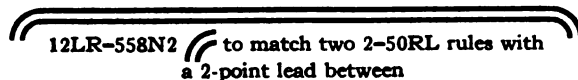
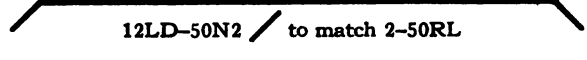
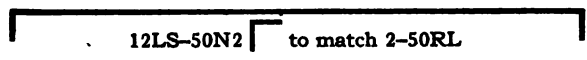
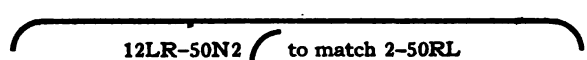
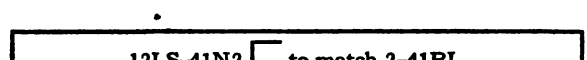
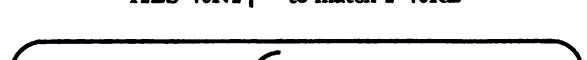
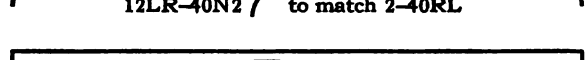
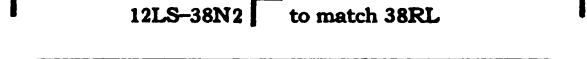
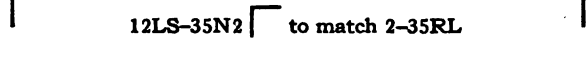
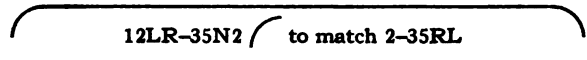
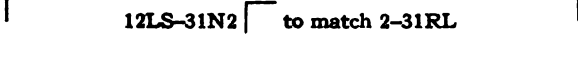
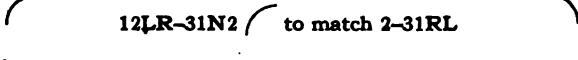
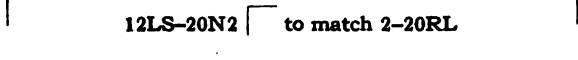
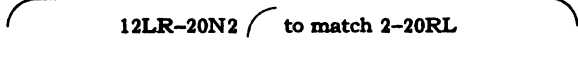
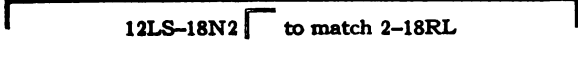
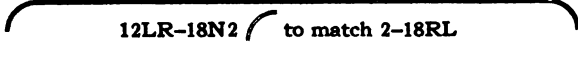
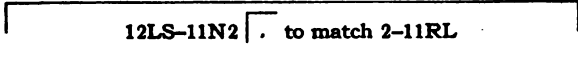
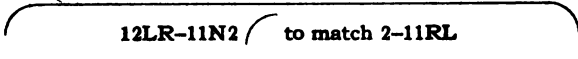
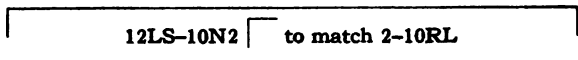
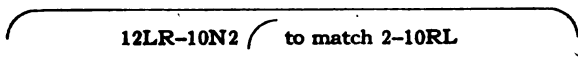



# Monotype Corner Pieces

## Matching Monotype Rules made on Continuous Lead and Rule Molds

### 12-Point Composition Corner Pieces to Match 3-Point Lead and Rule Matrices

12LR-41N3  to match 3-41RL

12LR-3428N3  to match 3-3428RL

12LD-41N3  to match 3-41RL

12LS-3428N3  to match 3-3428RL

12LR-248N3  to match 3-248RL

12LR-410N3  to match 3-410RL

12LR-61N3  to match 3-61RL

12LR-65N3  to match 3-65RL

12LD-65N3  to match 3-65RL

### 12-Point Composition Corner Pieces to Match 4-Point Lead and Rule Matrices

12LR-60N4  to match 4-60RL

### 12-Point Composition Corner Pieces to Match 12-Point Lead and Rule Matrices

12LR-40N  to match 12-40RL

12LS-4251N  to match 12-4251RL

12LS-40N  to match 12-40RL

12LR-424N  to match 12-424RL

12LR-4271N  to match 12-4271RL

12LS-424N  to match 12-424RL

12LS-4271N  to match 12-4271RL

12LR-536N  to match 12-536RL

12LR-4261N  to match 12-4261RL

12LS-536N  to match 12-536RL

12LS-4261N  to match 12-4261RL

12LR-961N  to match 12-961RL

12LR-4251N  to match 12-4251RL

12LS-961N  to match 12-961RL

# Monotype Corner Pieces

## Matching Monotype Rules made on Continuous Lead and Rule Molds

### 12-Point Electro Display Corner Pieces to Match 2-Point Lead and Rule Matrices

12LR-10-2  to match 2-10RL

12LR-41-2  to match 2-41RL

12LS-10-2  to match 2-10RL

12LS-41-2  to match 2-41RL

12LR-11-2  to match 2-11RL

12LD-41-2  to match 2-41RL

12LR-20-2  to match 2-20RL

12LR-50-2  to match 2-50RL

12LR-35-2  to match 2-35RL

12LS-50-2  to match 2-50RL

12LS-35-2  to match 2-35RL

12LD-50-2  to match 2-50RL

12LR-40-2  to match 2-40RL

12LT-50-2  to match 2-50RL

### 12-Point Electro Display Corner Pieces to Match 3-Point Lead and Rule Matrices

12LR-10-3  to match 3-10RL

### 12-Point Electro Display Corner Pieces to Match 6-Point Lead and Rule Matrices

12LR-10  to match 6-10RL

12LR-357  to match 6-357RL

12LS-10  to match 6-10RL

12LS-357  to match 6-357RL

12LR-11  to match 6-11RL

12LR-3531  to match 6-3531RL

12LR-1441  to match 6-1441RL

12LS-3531  to match 6-3531RL

12LR-147  to match 6-147RL

12LR-41  to match 6-41RL

12LR-1571  to match 6-1571RL

12LD-41  to match 6-41RL

12LR-181  to match 6-181RL

12LR-47  to match 6-47RL

12LR-35  to match 6-35RL

12LS-47  to match 6-47RL

12LS-35  to match 6-35RL

12LR-4225  to match 6-4225RL

12LS-4225  to match 6-4225RL

# Monotype Corner Pieces

## Matching Monotype Rules made on Continuous Lead and Rule Molds

### 12-Point Electro-Display Corner Pieces to Match 6-Point Lead and Rule Matrices

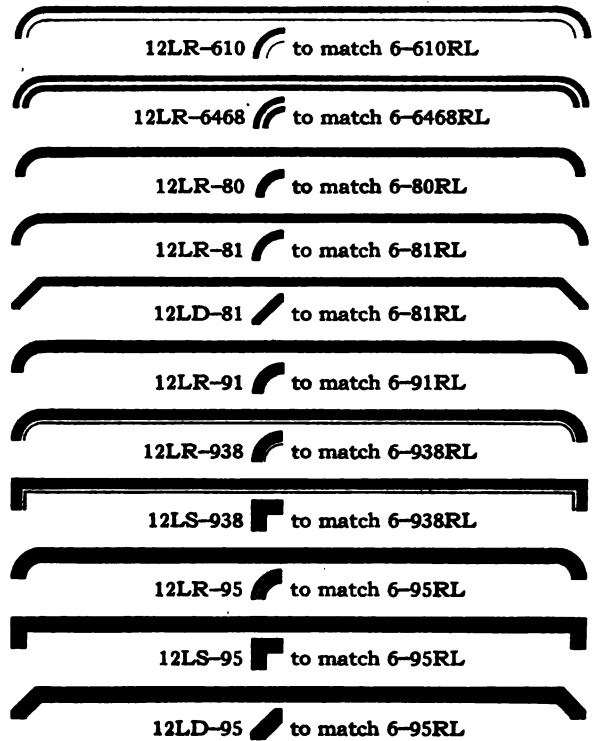
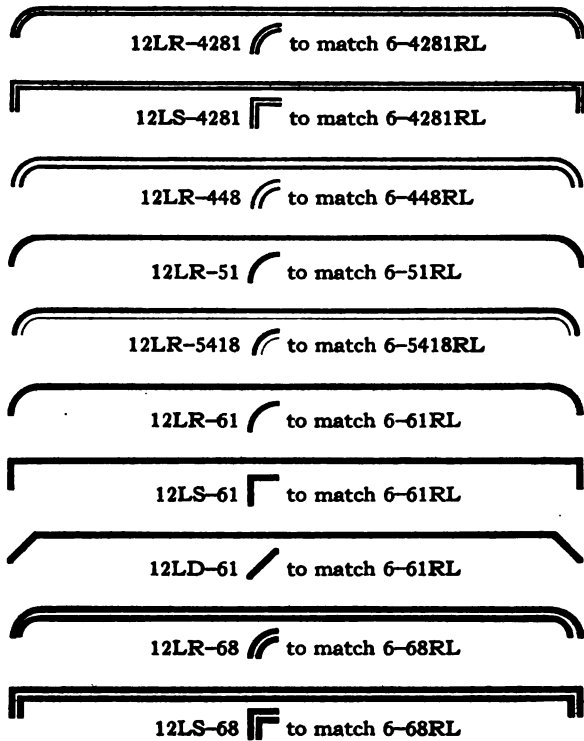

### 12-Point Electro-Display Corner Pieces to Match 12-Point Lead and Rule Matrices

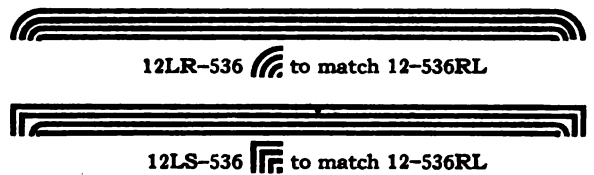
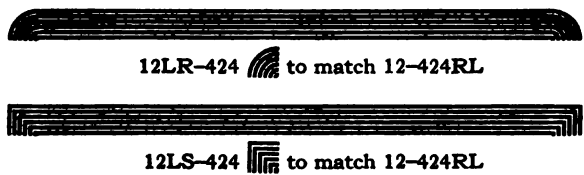

### 18-Point Electro-Display Corner Pieces to Match 2-Point Lead and Rule Matrices

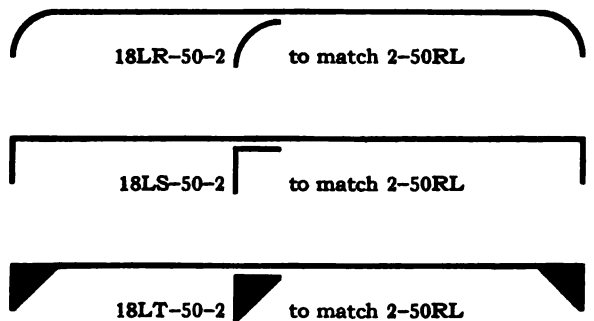
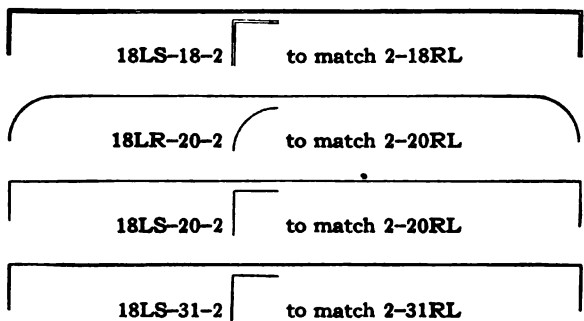

# Monotype Corner Pieces

## Matching Monotype Rules made on Continuous Lead and Rule Molds

### 18-Point Electro Display Corner Pieces to Match 6-Point Lead and Rule Matrices

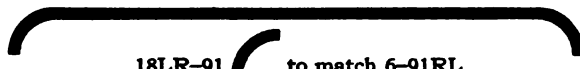
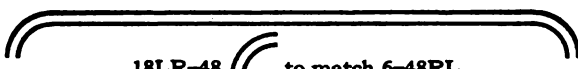
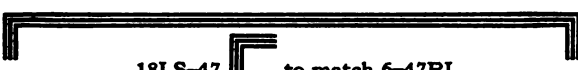
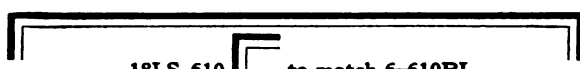
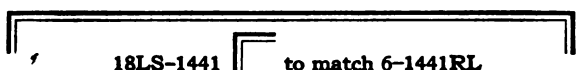
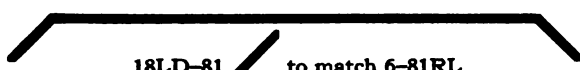
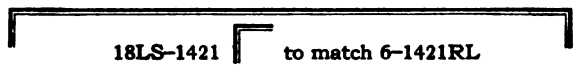

### 18-Point Electro Display Corner Pieces to Match 12-Point Lead and Rule Matrices

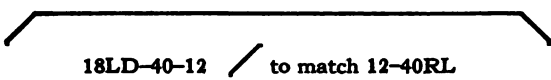

# Monotype Corner Pieces

## Matching Monotype Rules made on Continuous Lead and Rule Molds

### 24-Point Sorts Corner Pieces to Match 2-Point Lead and Rule Matrices

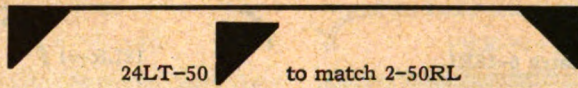

### 24-Point Sorts Corner Pieces to Match 6-Point Lead and Rule Matrices

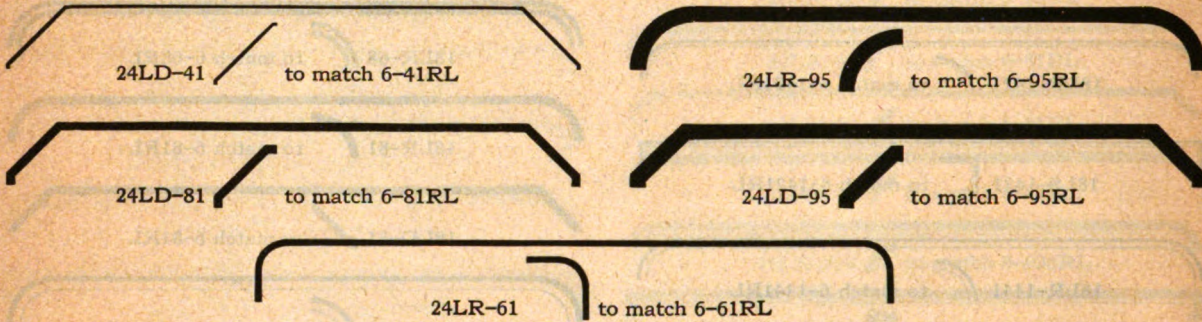

### 24-Point Sorts Corner Pieces to Match 12-Point Lead and Rule Matrices



### 30-Point Sorts Corner Pieces to Match 2-Point Lead and Rule Matrices

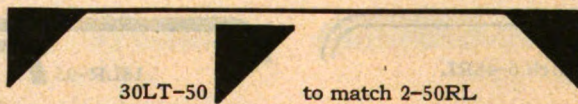

### 36-Point Sorts Corner Pieces to Match 2-Point Lead and Rule Matrices

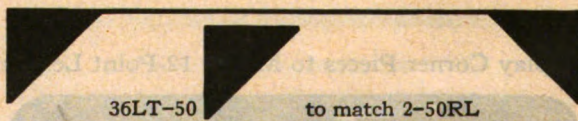

### 36-Point Sorts Corner Pieces to Match 6-Point Lead and Rule Matrices

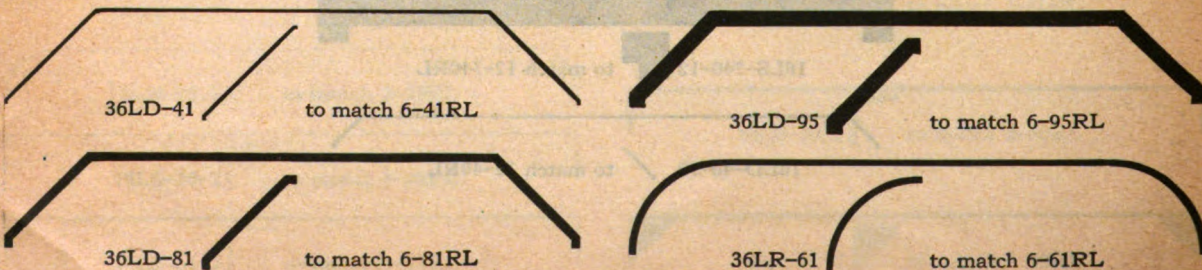

# Monotype Corner Pieces

## Matching Monotype Rules made on Continuous Lead and Rule Molds

### 6 x 36-Point Sorts Corner Pieces to Match 2-Point Lead and Rule Matrices

6 x 36LR-10 No. 1  to match 2-10RL

6 x 36LR-50 No. 1  to match 2-50RL

6 x 36LS-10 No. 1  to match 2-10RL

6 x 36LD-50 No. 1  to match 2-50RL

### 12 x 36-Point Sorts Corner Pieces to Match 2-Point Lead and Rule Matrices

12 x 36LD-50 No. 1  to match 2-50RL

12 x 36LT-50 No. 1  to match 2-50RL

### 6 x 36-Point Sorts Corner Pieces to Match 3-Point Lead and Rule Matrices

6 x 36LR-65 No. 1  to match 3-65RL

6 x 36LS-65 No. 1  to match 3-65RL

### 6 x 36-Point Sorts Corner Pieces to Match 6-Point Lead and Rule Matrices

6 x 36LR-10 No. 1  to match 6-10RL

6 x 36LR-181 No. 1  to match 6-181RL

6 x 36LS-10 No. 1  to match 6-10RL

6 x 36LR-181 No. 2  to match 6-181RL

6 x 36LR-11 No. 1  to match 6-11RL

6 x 36LR-1441 No. 1  to match 6-1441RL

6 x 36LR-11 No. 2  to match 6-11RL

6 x 36LS-1441 No. 1  to match 6-1441RL

6 x 36LR-18 No. 1  to match 6-18RL

6 x 36LR-147 No. 1  to match 6-147RL

6 x 36LR-18 No. 2  to match 6-18RL

6 x 36LR-147 No. 2  to match 6-147RL

6 x 36LR-1618 No. 1  to match 6-1618RL

6 x 36LS-147 No. 1  to match 6-147RL

6 x 36LR-1618 No. 2  to match 6-1618RL

6 x 36LR-1571 No. 1  to match 6-1571RL

6 x 36LS-1618 No. 1  to match 6-1618RL

6 x 36LS-1571 No. 1  to match 6-1571RL

6 x 36LS-1618 No. 2  to match 6-1618RL

6 x 36LR-20 No. 1  to match 6-20RL

6 x 36LR-1751 No. 2  to match 6-1751RL

6 x 36LS-20 No. 1  to match 6-20RL



# Monotype Corner Pieces

## Matching Monotype Rules made on Continuous Lead and Rule Molds

### 6 x 36-Point Sorts Corner Pieces to Match 6-Point Lead and Rule Matrices

6 x 36LR-3481 No. 1  to match 6-3481RL

6 x 36LR-4245 No. 1  to match 6-4245RL

6 x 36LS-3481 No. 1  to match 6-3481RL

6 x 36LR-4281 No. 1  to match 6-4281RL

6 x 36LR-3531 No. 1  to match 6-3531RL

6 x 36LR-4281 No. 2  to match 6-4281RL

6 x 36LS-3531 No. 1  to match 6-3531RL

6 x 36LS-4281 No. 1  to match 6-4281RL

6 x 36LR-3537 No. 1  to match 6-3537RL

6 x 36LS-4281 No. 2  to match 6-4281RL

6 x 36LR-3537 No. 2  to match 6-3537RL

6 x 36LR-448 No. 1  to match 6-448RL

6 x 36LR-357 No. 1  to match 6-357RL

6 x 36LR-448 No. 2  to match 6-448RL

6 x 36LS-357 No. 1  to match 6-357RL

6 x 36LS-448 No. 1  to match 6-448RL

6 x 36LS-357 No. 2  to match 6-357RL

6 x 36LR-4411 No. 1  to match 6-4411RL

6 x 36LR-367 No. 1  to match 6-367RL

6 x 36LR-4411 No. 2  to match 6-4411RL

6 x 36LS-367 No. 1  to match 6-367RL

6 x 36LS-4411 No. 1  to match 6-4411RL

6 x 36LR-41 No. 1  to match 6-41RL

6 x 36LS-4411 No. 2  to match 6-4411RL

6 x 36LR-41 No. 2  to match 6-41RL

6 x 36LR-4481 No. 1  to match 6-4481RL

6 x 36LS-41 No. 1  to match 6-41RL

6 x 36LR-4481 No. 2  to match 6-4481RL

6 x 36LS-41 No. 2  to match 6-41RL

6 x 36LS-4481 No. 1  to match 6-4481RL











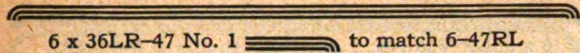

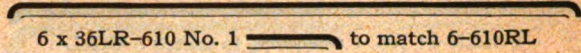

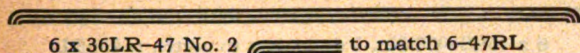

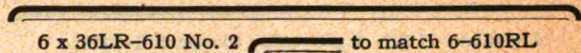



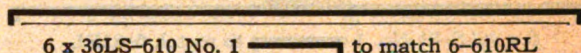

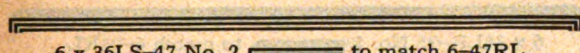

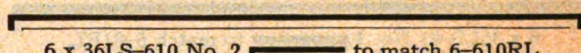



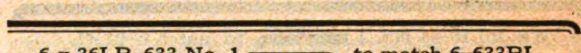

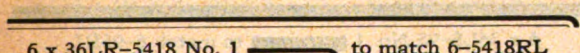



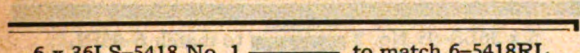



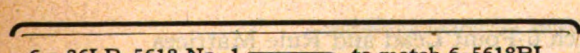

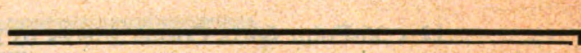

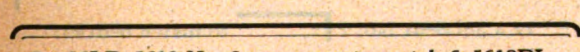

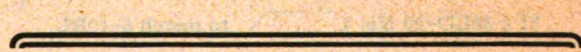



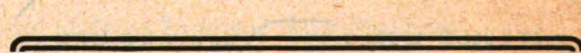

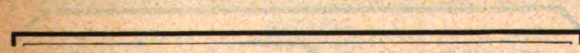

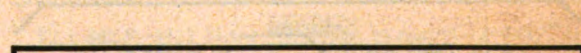





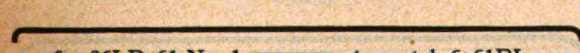





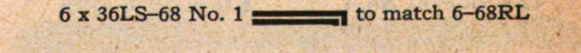

6 x 36LR-4225 No. 1  to match 6-4225RL

6 x 36LS-4225 No. 1  to match 6-4225RL

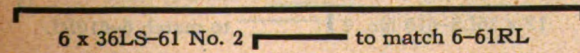
# Monotype Corner Pieces

## Matching Monotype Rules made on Continuous Lead and Rule Molds

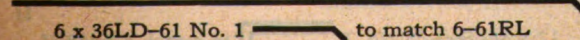
### 6 x 36-Point Sorts Corner Pieces to Match 6-Point Lead and Rule Matrices

|   |  |
|---|--|
|  6 x 36LR-47 No. 1  to match 6-47RL         |  6 x 36LR-610 No. 1  to match 6-610RL       |
|  6 x 36LR-47 No. 2  to match 6-47RL         |  6 x 36LR-610 No. 2  to match 6-610RL       |
|  6 x 36LS-47 No. 1  to match 6-47RL         |  6 x 36LS-610 No. 1  to match 6-610RL       |
|  6 x 36LS-47 No. 2  to match 6-47RL         |  6 x 36LS-610 No. 2  to match 6-610RL       |
|  6 x 36LR-51 No. 1  to match 6-51RL         |  6 x 36LR-633 No. 1  to match 6-633RL       |
|  6 x 36LR-5418 No. 1  to match 6-5418RL     |  6 x 36LS-633 No. 1  to match 6-633RL       |
|  6 x 36LS-5418 No. 1  to match 6-5418RL     |  6 x 36LR-648 No. 1  to match 6-648RL       |
|  6 x 36LR-5618 No. 1  to match 6-5618RL     |  6 x 36LS-648 No. 1  to match 6-648RL       |
|  6 x 36LR-5618 No. 2  to match 6-5618RL |  6 x 36LR-6468 No. 1  to match 6-6468RL |
|  6 x 36LS-5618 No. 1  to match 6-5618RL |  6 x 36LR-6468 No. 2  to match 6-6468RL |
|  6 x 36LS-5618 No. 2  to match 6-5618RL |  6 x 36LS-6468 No. 1  to match 6-6468RL |
|  6 x 36LR-581 No. 1  to match 6-581RL   |  6 x 36LS-6468 No. 2  to match 6-6468RL |
|  6 x 36LR-61 No. 1  to match 6-61RL     |  6 x 36LR-68 No. 1  to match 6-68RL     |
|  6 x 36LR-61 No. 2  to match 6-61RL     |  6 x 36LS-68 No. 1  to match 6-68RL     |
|  6 x 36LS-61 No. 1  to match 6-61RL     |  6 x 36 LR-758 No. 1  to match 6-758RL  |
|  6 x 36LS-61 No. 2  to match 6-61RL     |  6 x 36LR-758 No. 2  to match 6-758RL   |
|  6 x 36LD-61 No. 1  to match 6-61RL     |  |

# Monotype Corner Pieces

## Matching Monotype Rules made on Continuous Lead and Rule Molds

### 6 x 36-Point Sorts Corner Pieces to Match 6-Point Lead and Rule Matrices

6 x 36LR-81 No. 1  to match 6-81RL

6 x 36LR-938 No. 2  to match 6-938RL

6 x 36LR-81 No. 2  to match 6-81RL

6 x 36LS-938 No. 1  to match 6-938RL

6 x 36LS-81 No. 1  to match 6-81RL

6 x 36LS-938 No. 2  to match 6-938RL

6 x 36LS-81 No. 2  to match 6-81RL

6 x 36LR-95 No. 1  to match 6-95RL

6 x 36LR-91 No. 1  to match 6-91RL

6 x 36LR-95 No. 2  to match 6-95RL

6 x 36LR-91 No. 2  to match 6-91RL

6 x 36LS-95 No. 1  to match 6-95RL

6 x 36LR-938 No. 1  to match 6-938RL

6 x 36LS-95 No. 2  to match 6-95RL

### 12 x 36-Point Sorts Corner Pieces to Match 6-Point Lead and Rule Matrices

12 x 36LD-10 No. 1  to match 6-10RL

12 x 36LS-61 No. 2  to match 6-61RL

12 x 36LD-41 No. 1  to match 6-41RL

12 x 36LD-61 No. 1  to match 6-61RL

12 x 36LD-41 No. 2  to match 6-41RL

12 x 36LD-61 No. 2  to match 6-61RL

12 x 36LR-5618 No. 1  to match 6-5618RL

12 x 36LR-610 No. 1  to match 6-610RL

12 x 36LS-5618 No. 1  to match 6-5618RL

12 x 36LR-610 No. 2  to match 6-610RL

12 x 36LR-61 No. 1  to match 6-61RL

12 x 36LS-610 No. 1  to match 6-610RL

12 x 36LR-61 No. 2  to match 6-61RL

12 x 36LS-610 No. 2  to match 6-610RL

12 x 36LS-61 No. 1  to match 6-61RL

12 x 36LS-6468 No. 1  to match 6-6468RL

# Monotype Corner Pieces

## Matching Monotype Rules made on Continuous Lead and Rule Molds

### 12 x 36-Point Sorts Corner Pieces to Match 6-Point Lead and Rule Matrices

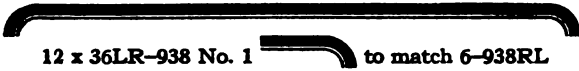
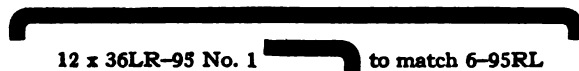
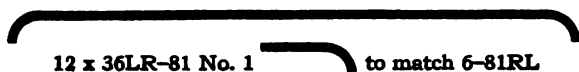

### 12 x 36-Point Sorts Corner Pieces to Match 12-Point Lead and Rule Matrices

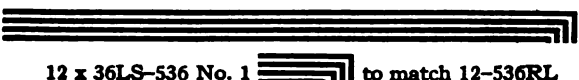
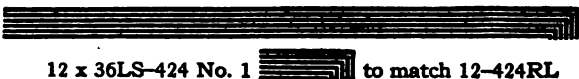

# Monotype Corner Pieces

## Matching Monotype Rules made on Continuous Lead and Rule Molds

### 12-Point Corner Pieces to Match Combinations of Monotype Rule

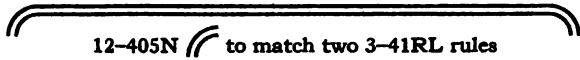

12-405N to match two 3-41RL rules

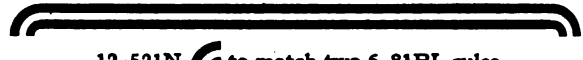

12-521N to match two 6-81RL rules

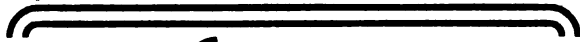

12-520N to match two 6-61RL rules



12-522N to match two 6-91RL rules

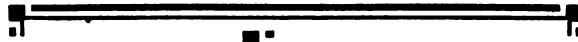

12-425N to match 6-648RL

### 18-Point Corner Pieces to Match Combinations of Monotype Rule

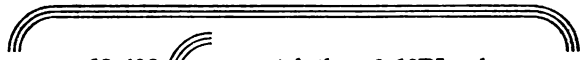

18-406 to match three 2-10RL rules

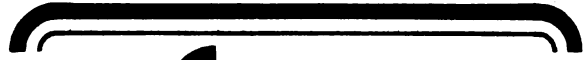

18-408 to match 6-95RL  
6-41RL

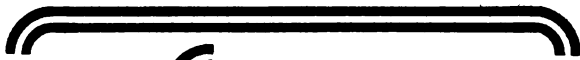

18-407 to match two 6-81RL rules



18-440 to match three 6-47RL rules



18-441 to match two 6-47RL rules

### 24-Point Corner Pieces to Match Combinations of Monotype Rule

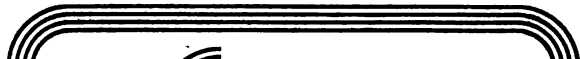

24-411 to match four 3-41RL rules

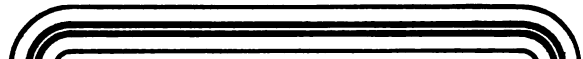

24-413 to match 6-41RL  
6-68RL  
6-41RL

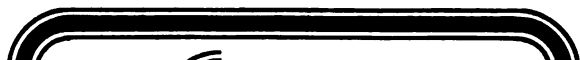

24-412 to match 3-41RL  
6-95RL  
3-41RL



24-414 to match 6-95RL  
6-10RL  
6-95RL

### 36-Point Corner Pieces to Match Combinations of Monotype Rule

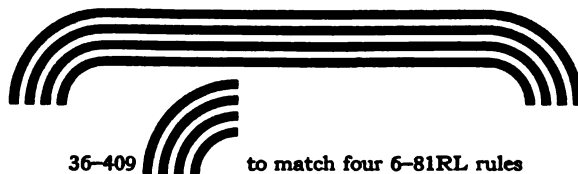























36-409 to match four 6-81RL rules

# MATRICES

## FOR

# Set Ems Charts

### Set-Ems Matrices with their Matrix Symbols

- 5Y-50S1  Blanks
- 5Y-50S2  Blanks
- 5Y-50S3  Blanks
- 5Y-50S4  Em Extensions
- 5Y-50S5  Em Extensions
- 5Y-50S6  Em Extensions
- 5Y-50S7  Line Extensions
- 5Y-50S8  Line Extensions
- 5Y-50Sf9  Nut Extensions
- 5Y-50Sf10  Nut Extensions
- 5Y-51S20  Numbers
- 5Y-51S30  Numbers
- 5Y-51S31  Numbers
- 5Y-51S32  Numbers
- 5Y-51S33  Numbers
- 5Y-51S34  Numbers
- 5Y-51S35  Numbers
- 5Y-51S36  Numbers
- 5Y-51S37  Numbers
- 5Y-51S38  Numbers
- 5Y-51S39  Numbers
- 5Y-51S41  Numbers

**Total 22 Matrices**

The application of the principle of the relation of copy to type enables the Monotype Printer to accurately determine the amount of space copy will make when composed in any size or style of type; but in illustrated matter it is important that the actual space covered by the cuts and their margins, expressed in set ems of the type to be used, should also be predetermined; therefore, an extension of this system is required for cut measurement and also to provide for definite instructions for the keyboard operator.

This set of twenty-two matrices have been specially designed for this purpose, in order that the Monotype Printer, by their use, may be able to make Set Ems Charts of any size, for any purpose, and to match any possible combination of set sizes and point bodies.

Page two shows exhibits of varied methods of making charts of any size, with complete explanation of the use of the matrices.

Pages three and four show the application of Set Ems Charts to three totally different kinds of work, using the charts in a different manner for each. From these suggestions it will be noted that the use of these charts will pave the way for much greater economies in the production of all kinds of Monotype matter, and, at the same time, enable the work of preparation to be more thorough and efficient.

These matrices are made to run solid for 5 point, 6 set, the smallest size used in general work. They can be *opened-up*, either with white space or with line, em and nut extensions, to 36 point, 36 set, or larger if desired. Sold at "Class A" prices for single matrices.

**LANSTON MONOTYPE MACHINE CO.**  
Philadelphia

**No. 1 5 Point—6 Set**

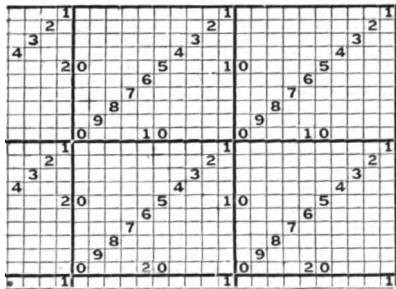

Use Typewriter Attachment  
Wedge, 6 Set, .0830"  
Mold, 5 Point, .0692"

**No. 2 6 Point—7 Set**

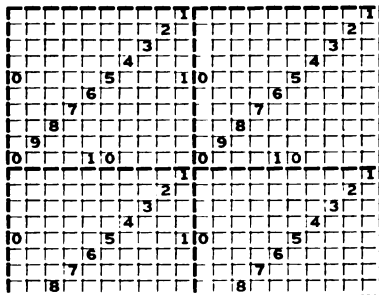

Use Typewriter Attachment  
Wedge, 7 Set, .0968"  
Mold, 6 Point, .0830"

**No. 3 8 Point—8 Set**

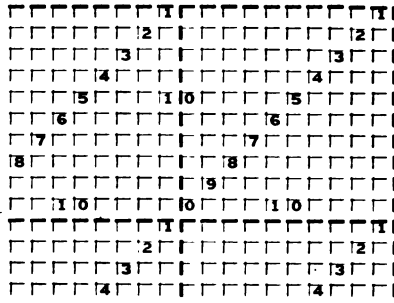

Use Typewriter Attachment  
Wedge, 8 Set, .1107"  
Mold, 8 Point, .1107"

**No. 4 8 Point—8½ Set**

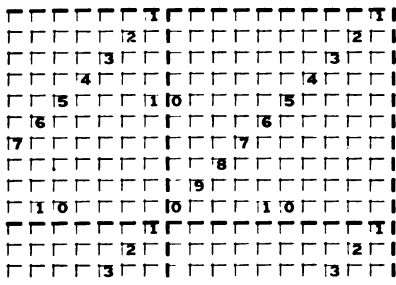

Use Typewriter Attachment  
Wedge, 8½ Set, .1176"  
Mold, 8 Point, .1107"

## How To Make Set Ems Charts

All the charts shown on this page, except No. 6, are made with the use of the Typewriter Attachment, as all the characters are on the 18 unit body.

Use the figure positions on the left key-bank for the figure matrices symbolized 5Y-51S30 to 5Y-51S39, inclusive. Place 5Y-51S41 on dollar mark on left key-bank. Place all other characters on row below those mentioned above.

Charts numbered 1, 2, 3, 4, 5, and 7 are all made from the same keyboard ribbon, up to the limits of delivery on the casting machine, 42 or 60 picas.

Chart No. 7, Square-Point Chart, is used for measuring composition space. Its purpose and manner of using is explained in paragraphs 81 to 91 inclusive, of "Copyfitting."

Charts numbered 8 and 9 show the use of "Em Set Extensions" and "Vertical Line Extensions," with the half size wedge and mold.

Chart No. 10 shows the use of double extensions both ways, with the wedge and mold of one-third size. This plan can be extended indefinitely.

When making charts similar to No. 6, requiring the "Nut Extensions," the fourteen positions on the 18 unit row of the matrix case must be used for the important 18 unit characters, the balance being inserted by hand. S15 or S108 Normal Wedges will accommodate all of the 18 unit characters.

Chart No. 6 demonstrates this use of the "Nut Set Extensions," as well as the "Vertical Line Extensions."

**No. 6 10 Point—10¼ Set**

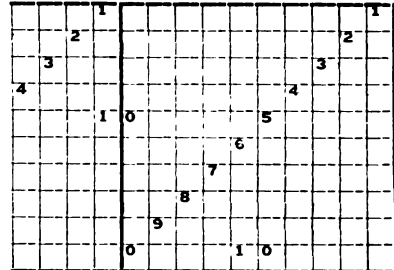

Use 6¼ Set Normal Wedge  
18 Unit Size, .0943"  
9 Unit Size, .0476"  
Mold, 5 Point, .0692"

**No. 5 12 Point—12 Set**

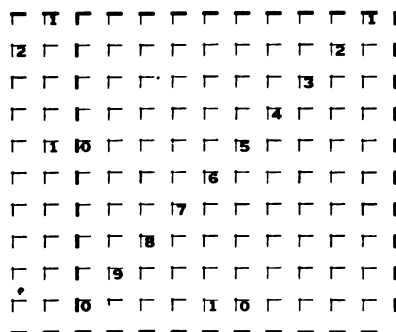

Use Typewriter Attachment  
Wedge, 12 Set, .1660"  
Mold, 12 Point, .1660"

**No. 7 Square-Point Chart**

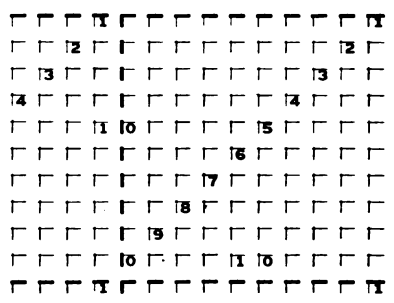

Use Typewriter Attachment  
Wedge, 10 Set, .1383"  
Mold, 10 Point, .1383"

**No. 8 12 Point—12 Set**

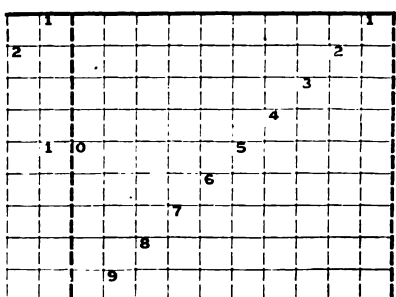

Use Typewriter Attachment  
Wedge, 6 Set, .0830"  
Mold, 6 Point, .0830"

**No. 9 18 Point—18 Set**

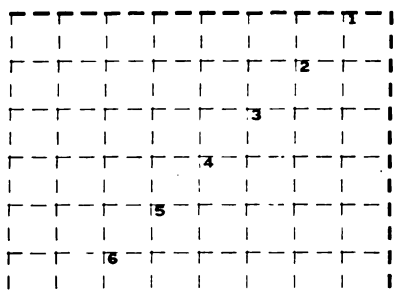

Use Typewriter Attachment  
Wedge, 9 Set, .1245"  
Mold, 9 Point, .1245"

**No. 10 18 Point—18 Set**

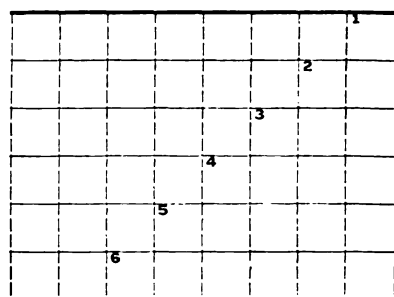

Use Typewriter Attachment  
Wedge, 6 Set, .0830"  
Mold, 6 Point, .0830"

# Magazine and Book Work

For work of this class when the article usually runs from page to page, the page is the unit of the layout. The Set Ems Chart is therefore made a part of the page dummy, using a separate chart for each column in the page.

FOLIO

RUNNING HEAD

FOLIO

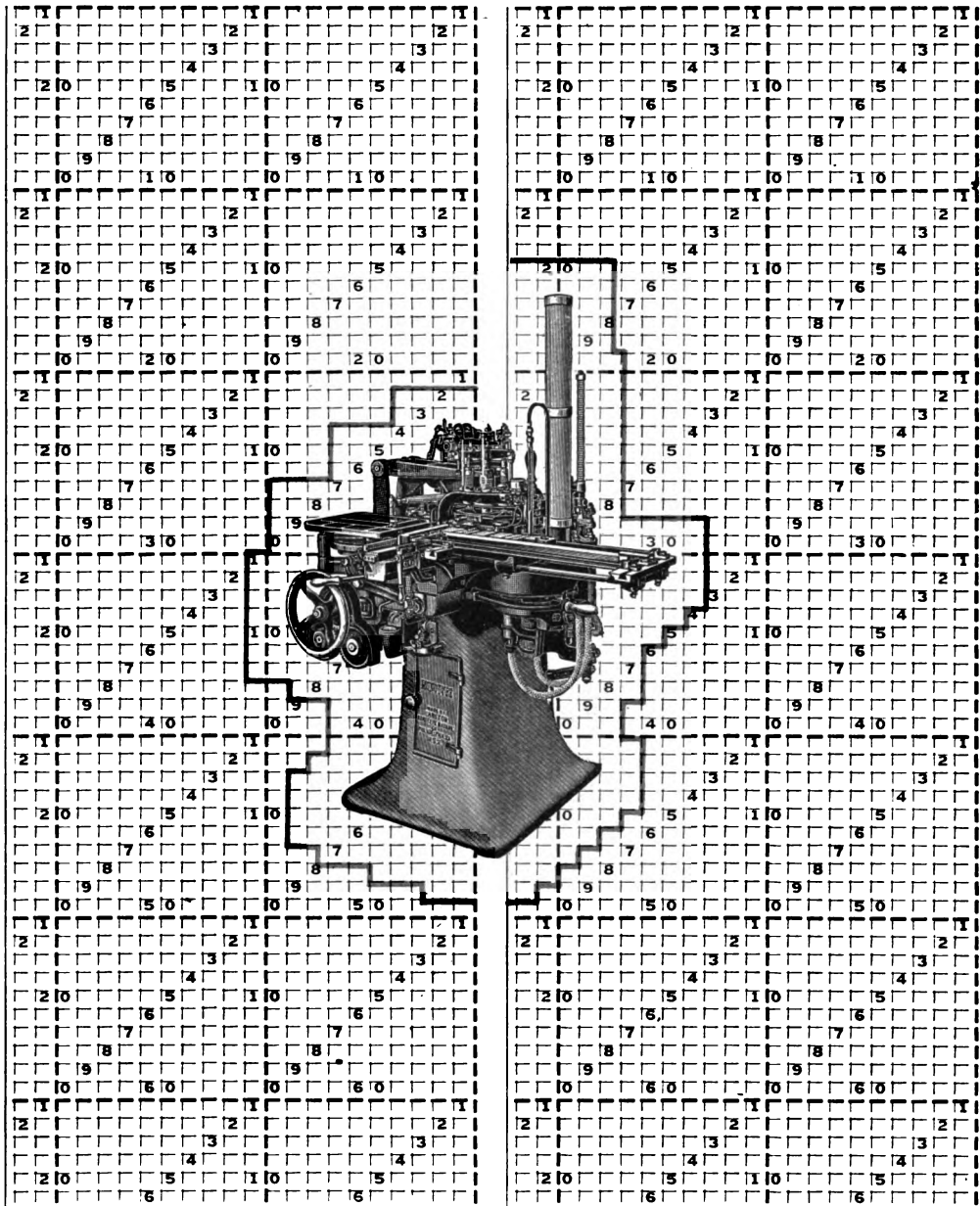

7 Point—8 Set

First trim the proof of the illustration fairly close to its outline and paste it in correct position on the dummy. When the proper margin from the edge of the illustration to the type is determined, draw in the red line. This shows the place where the type is to start or stop.

It is a good rule never to split a half-em except when following a curve, and when it is necessary to split the half-em, the unit size should be marked alongside the red line.

The exhibit in this page is an illustration of this use of Set Ems Charts for a two-column page.



## Illustrated Catalog Work

The value of these charts for the making of catalogs which are intended to dispose of merchandise direct to the consumer is probably greater than for any other of their varied uses, as for this kind of work the listing is the unit, and the following of the outline of the illustration, as closely and accurately as may be desired, is especially important.

The exhibit on the left is a reproduction of a chart for catalog work which was made as follows: a good proof of the illustration was taken on fairly heavy paper with lots of margin; then the thin paper chart of selected point and set size, was registered over the cut, using the perpendicular lines to obtain position, and then the chart was pasted down on the proof.

It was easy to correctly position and mark the red line as the illustration showed plainly through the chart, and the end of the article is indicated by a red line. The chart is trimmed close on each side to the type measure, but an inch margin is allowed at top and bottom for convenience in handling in the copy holder. In the top margin was entered the measure in picas and also in ems of the set to be used, as well as the number of lines.

## Blank Work

Charts to be used for laying out blank work should be printed in red ink on heavy writing paper. Lines can be drawn in pencil or black ink showing the style of the rules and their position. Headings and stubs can either be written in proper position on the chart, or symbolized to refer to a separate piece of copy (writing the headings and stubs on the charts will reduce the time of mechanical production more than the time of writing).

The exhibit below is an example of this method, but instead of making an engraving of the marking on the chart, the completed job has been over-printed on the Set Ems Chart.

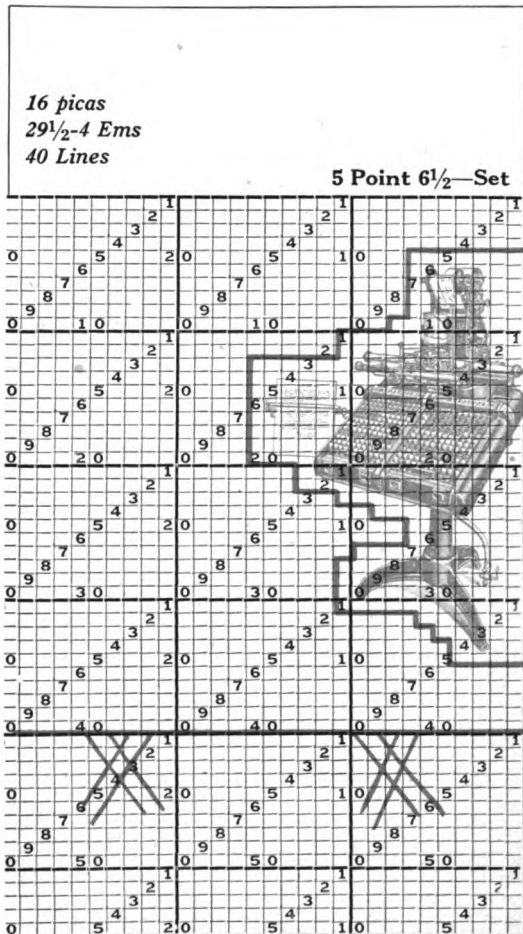

6 Point-7 Set

| DAILY LOCATION |                     | RECAPITULATION               |                     | CASH ACCOUNT                   |                     |
|----------------|---------------------|------------------------------|---------------------|--------------------------------|---------------------|
| SUNDAY         | 5 4 3 2 1 0         | RAILROAD FARE                | 5 4 3 2 1 0         | ON HAND                        | 5 4 3 2 1 0         |
| MONDAY         | 9 8 7 6 5 4 3 2 1 0 | SLEEPING CAR                 | 9 8 7 6 5 4 3 2 1 0 | WEEK ENDING (DATE)             | 9 8 7 6 5 4 3 2 1 0 |
| TUESDAY        | 3 2 1 0             | TELEGRAMS                    | 3 2 1 0             | RECEIVED FROM                  | 3 2 1 0             |
| WEDNESDAY      | 5 4 3 2 1 0         | TELEPHONES                   | 5 4 3 2 1 0         | OFFICE                         | 5 4 3 2 1 0         |
| THURSDAY       | 9 8 7 6 5 4 3 2 1 0 | ALLOWANCE AND OTHER EXPENSES | 9 8 7 6 5 4 3 2 1 0 | RECEIVED FROM CUSTOMER         | 9 8 7 6 5 4 3 2 1 0 |
| FRIDAY         | 3 2 1 0             | TOTALS                       | 3 2 1 0             | ACCOUNT OF SALARY              | 3 2 1 0             |
| SATURDAY       | 5 4 3 2 1 0         | O.K.                         | 5 4 3 2 1 0         | EXPENSES                       | 5 4 3 2 1 0         |
|                |                     |                              |                     | DATE                           |                     |
|                |                     |                              |                     | TOTAL ON HAND THIS WEEK        |                     |
|                |                     |                              |                     | TOTAL EXPENSE THIS WEEK        |                     |
|                |                     |                              |                     | AMOUNT DUE NOW ON HAND         |                     |
|                |                     |                              |                     | <b>DO NOT WRITE BELOW HERE</b> |                     |
|                |                     |                              |                     | SALARY                         |                     |
|                |                     |                              |                     | TOTAL AMOUNT CHECK             |                     |

No leads or rules are used in this blank, it was produced complete by one operation of the Keyboard and Caster, using the Monotype T Series of Cross Rules for Blank Work.

# MONOTYPE BORDERS *and* ORNAMENTS

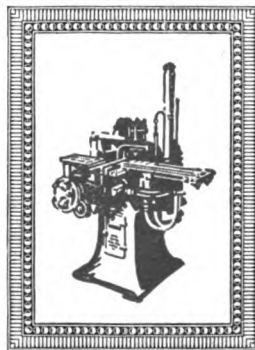

The following pages are an advance showing of several hundred Monotype Border Matrices now available. Additional sheets showing borders now in stock, as well as many new borders in preparation, will be sent out as issued.



















COPYRIGHT, 1917  
BY  
LANSTON MONOTYPE  
MACHINE COMPANY

TRADE MARK  
**MONOTYPE**  
Reg. U. S. Pat. Off.

# Monotype Borders

All Border Matrices are rated as Class A,  
except those otherwise specified



















|   |   |
|---|---|
|    |    |
| 14 Point No. 121  | 14 Point No. 122  |
|    |    |
| 18 Point No. 27   | 18 Point No. 26A  |
|    |    |
| 18 Point No. 26B  | 18 Point No. 26C  |
|    |    |
| 18 Point No. 118  | 18 Point No. 25   |
|  |  |
| 18 Point No. 120  | 18 Point No. 119  |
|  |  |
| 18 Point No. 114  | 18 Point No. 28   |
|  |  |
| 24 Point No. 114  | 24 Point No. 28   |
|  |  |
| 30 Point No. 114  | 30 Point No. 28   |
|  |  |
| 36 Point No. 114  | 36 Point No. 28   |

# Monotype Borders

All Border Matrices are rated as Class A, except those otherwise specified



|   |   |
|---|---|
|    |    |
| 12 Point No. 335  | 12 Point No. 334  |
|    |    |
| 18 Point No. 335  | 18 Point No. 334  |
|    |    |
| 18 Point No. 290  | 18 Point No. 63   |
|    |    |
| 18 Point No. 185  | 18 Point No. 182  |
|  |  |
| 24 Point No. 185  | 24 Point No. 182  |
|  |  |
| 30 Point No. 185  | 30 Point No. 182  |
|  |  |
| 36 Point No. 185  | 36 Point No. 182  |
|  |  |
| 24 Point No. 65   | 30 Point No. 65   |
|   |    |
|   | 36 Point No. 288  |

# Monotype Borders



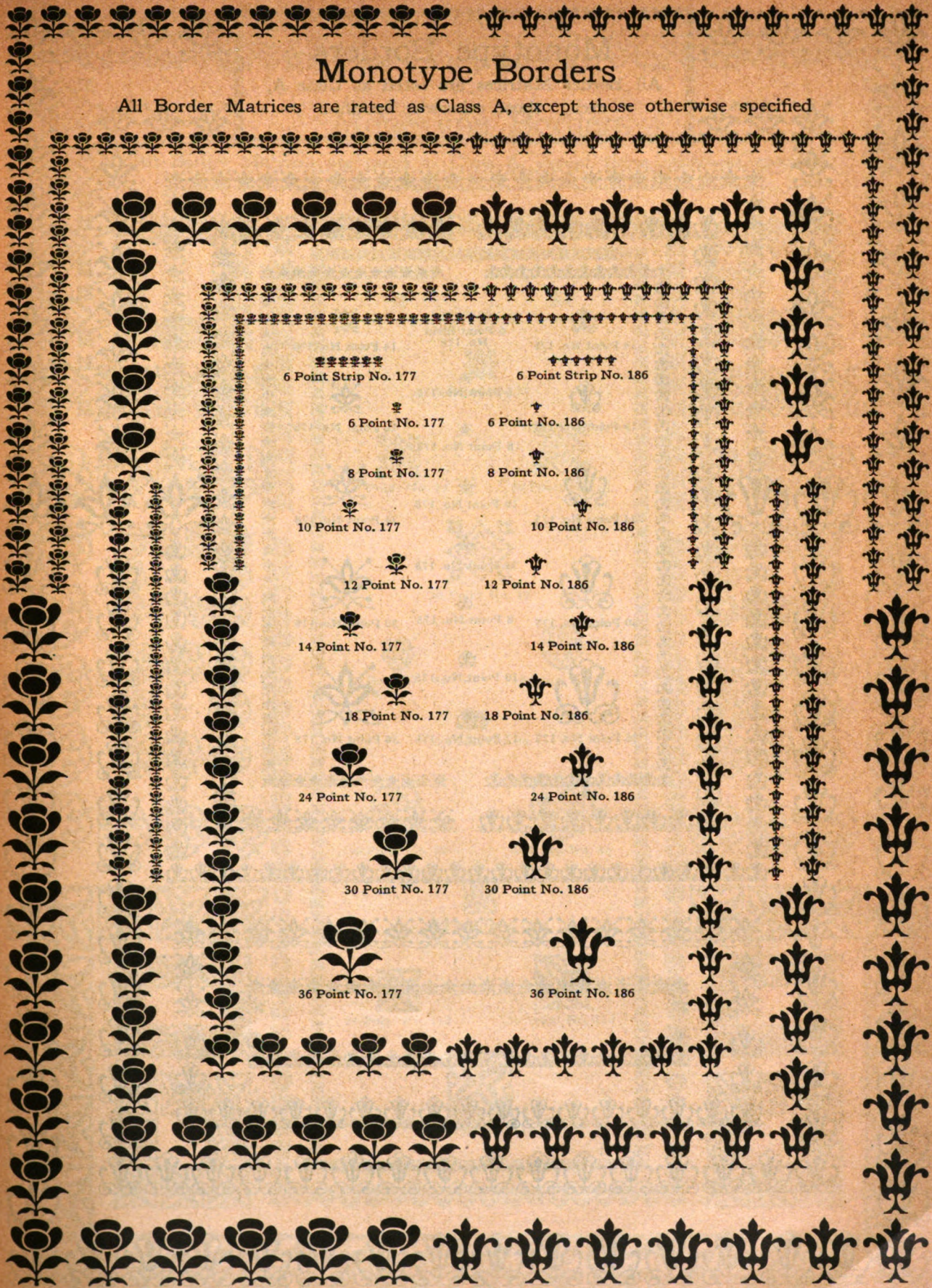





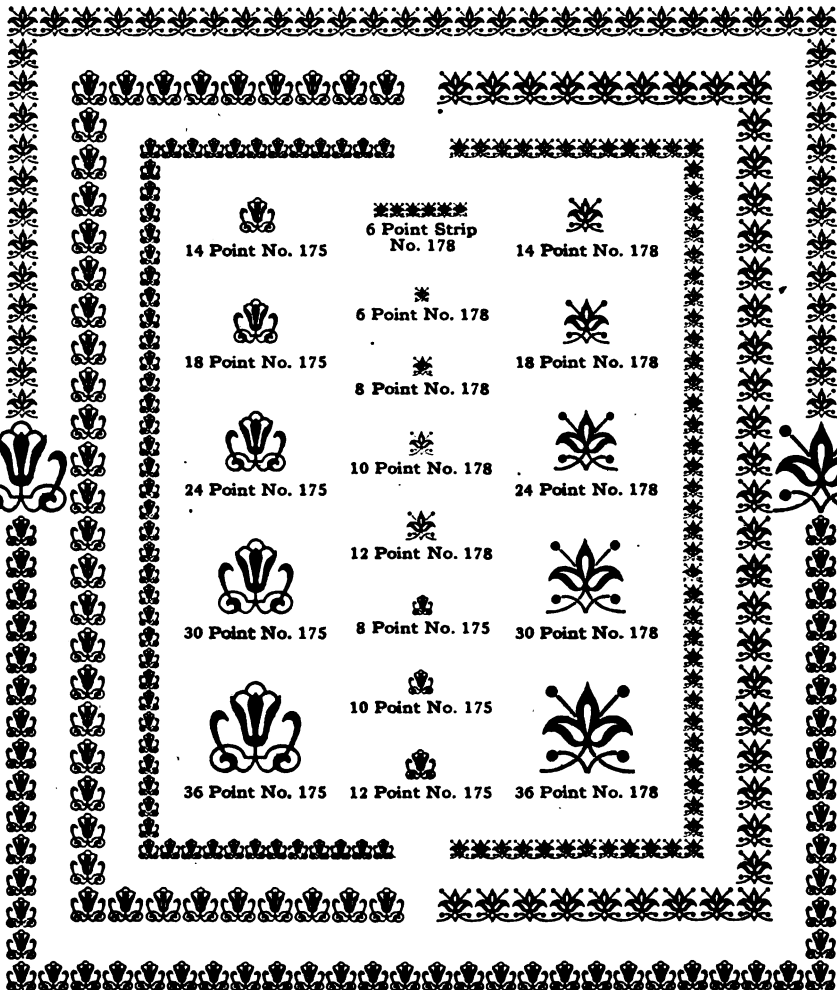

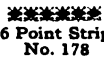







All Border Matrices are rated as Class A, except those otherwise specified





# Monotype Borders

All Border Matrices are rated as Class A,  
except those otherwise specified

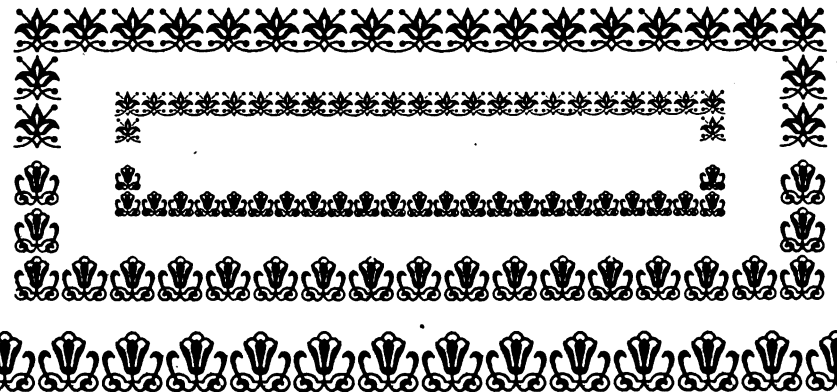

|   |   |  |
|---|---|--|
| <br>14 Point No. 175   | <br>6 Point Strip<br>No. 178 | <br>14 Point No. 178  |
| <br>18 Point No. 175   | <br>6 Point No. 178          | <br>18 Point No. 178  |
| <br>8 Point No. 178    | <br>10 Point No. 178         | <br>24 Point No. 178  |
| <br>24 Point No. 175   | <br>12 Point No. 178         | <br>30 Point No. 178  |
| <br>30 Point No. 175   | <br>8 Point No. 175          | <br>30 Point No. 175  |
| <br>36 Point No. 175  | <br>10 Point No. 175         | <br>36 Point No. 178 |
| <br>12 Point No. 175 |   |  |



|  |
|--|
|  |
|  |

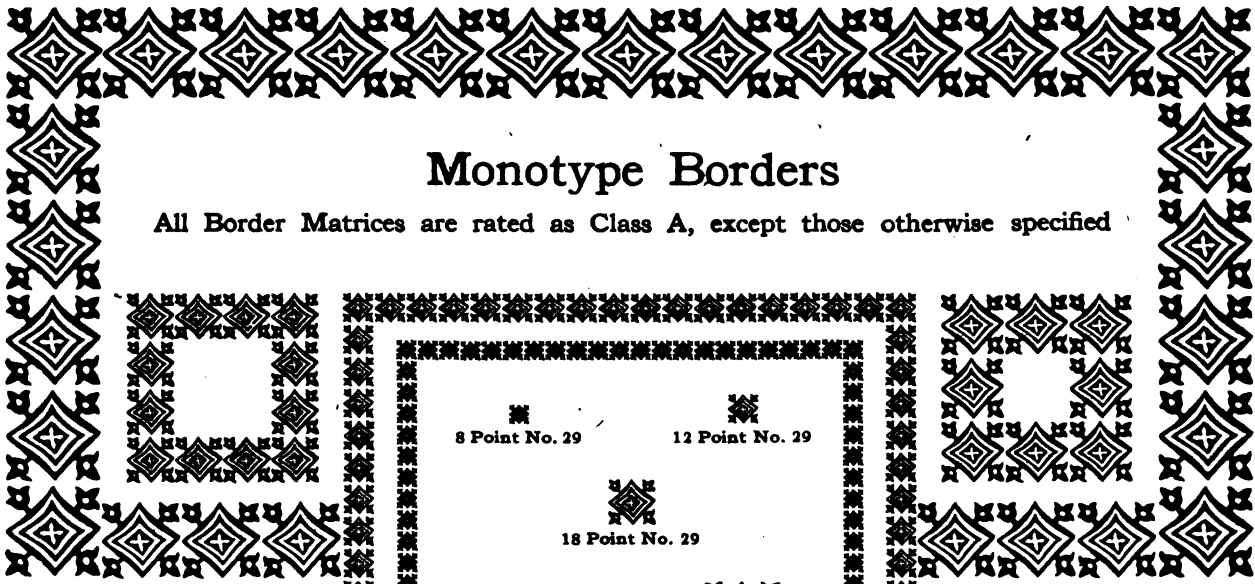

# Monotype Borders

All Border Matrices are rated as Class A, except those otherwise specified

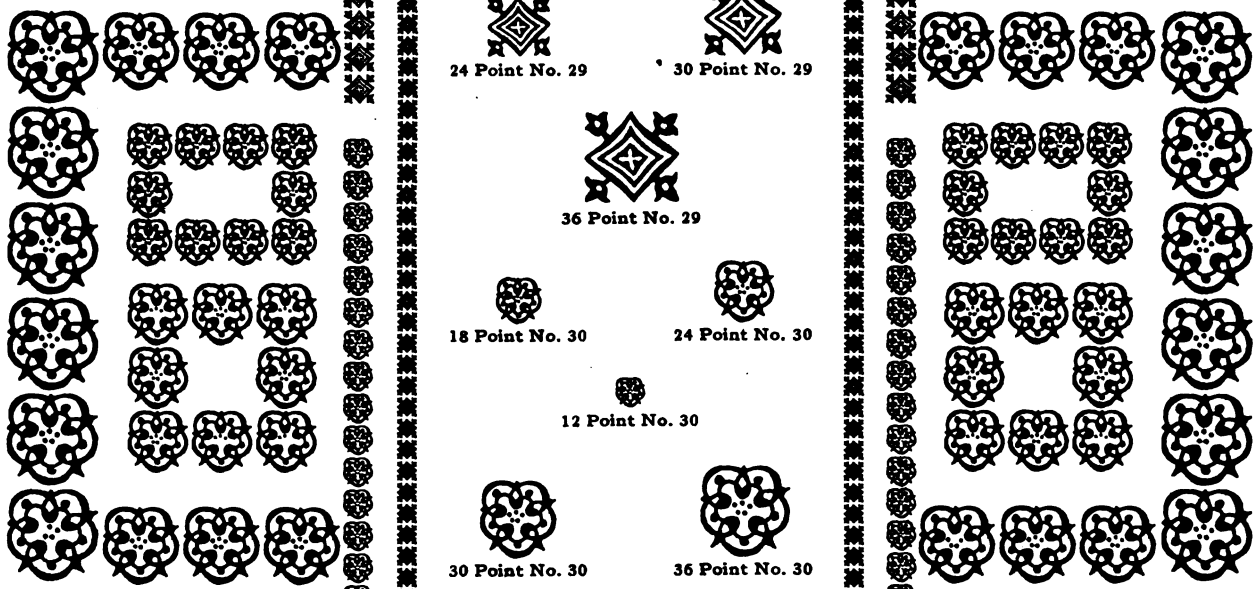

8 Point No. 29

12 Point No. 29

18 Point No. 29

24 Point No. 29

30 Point No. 29

36 Point No. 29

18 Point No. 30

24 Point No. 30

12 Point No. 30

30 Point No. 30

36 Point No. 30

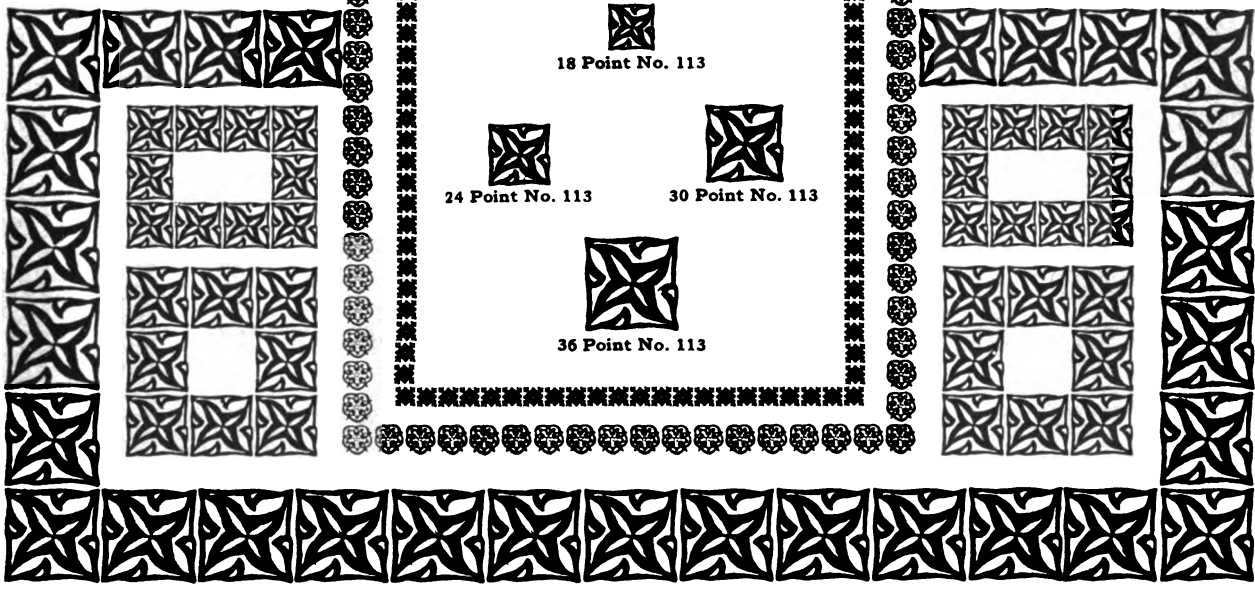

18 Point No. 113

24 Point No. 113

30 Point No. 113

36 Point No. 113



# Monotype Borders



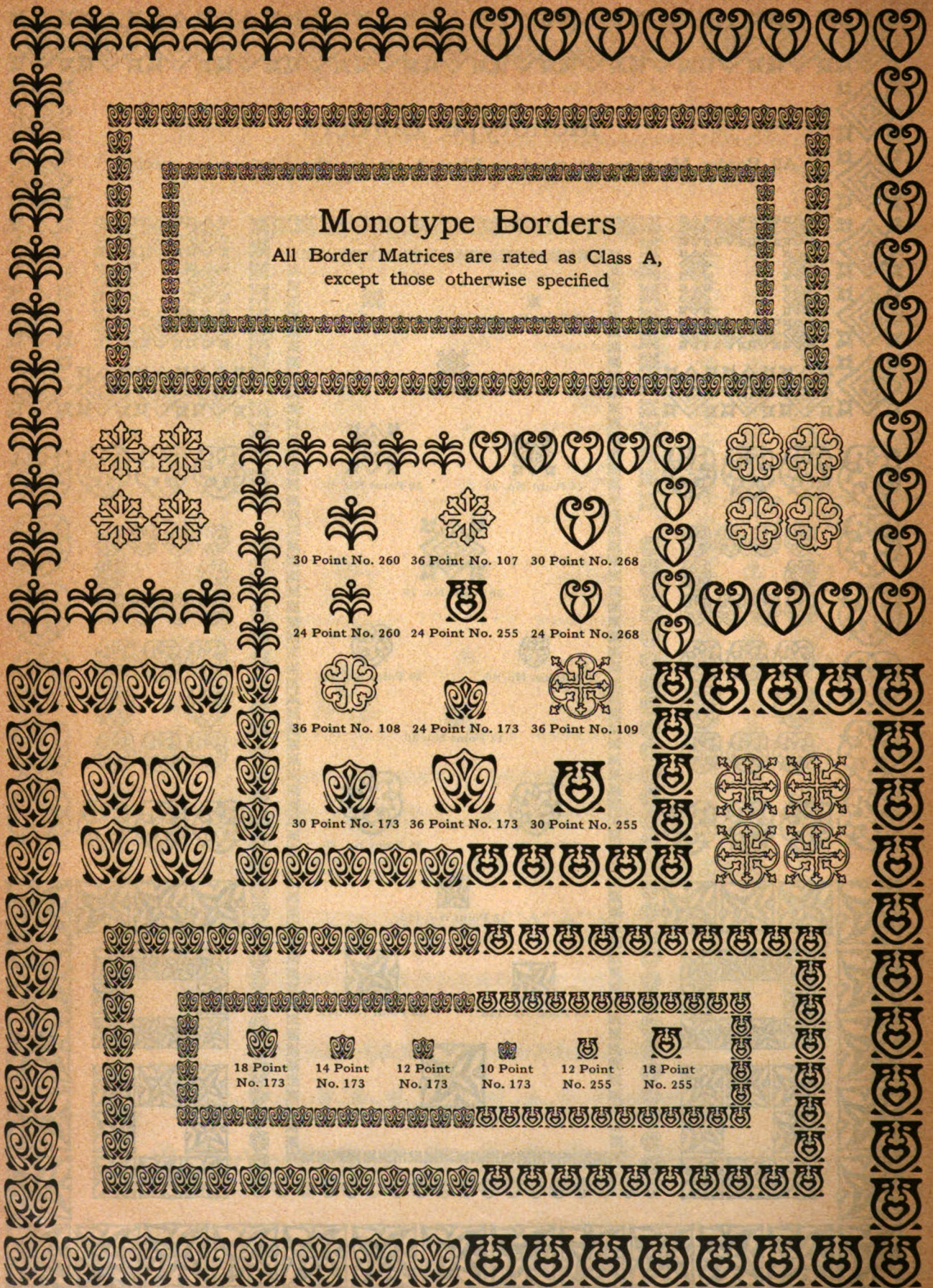





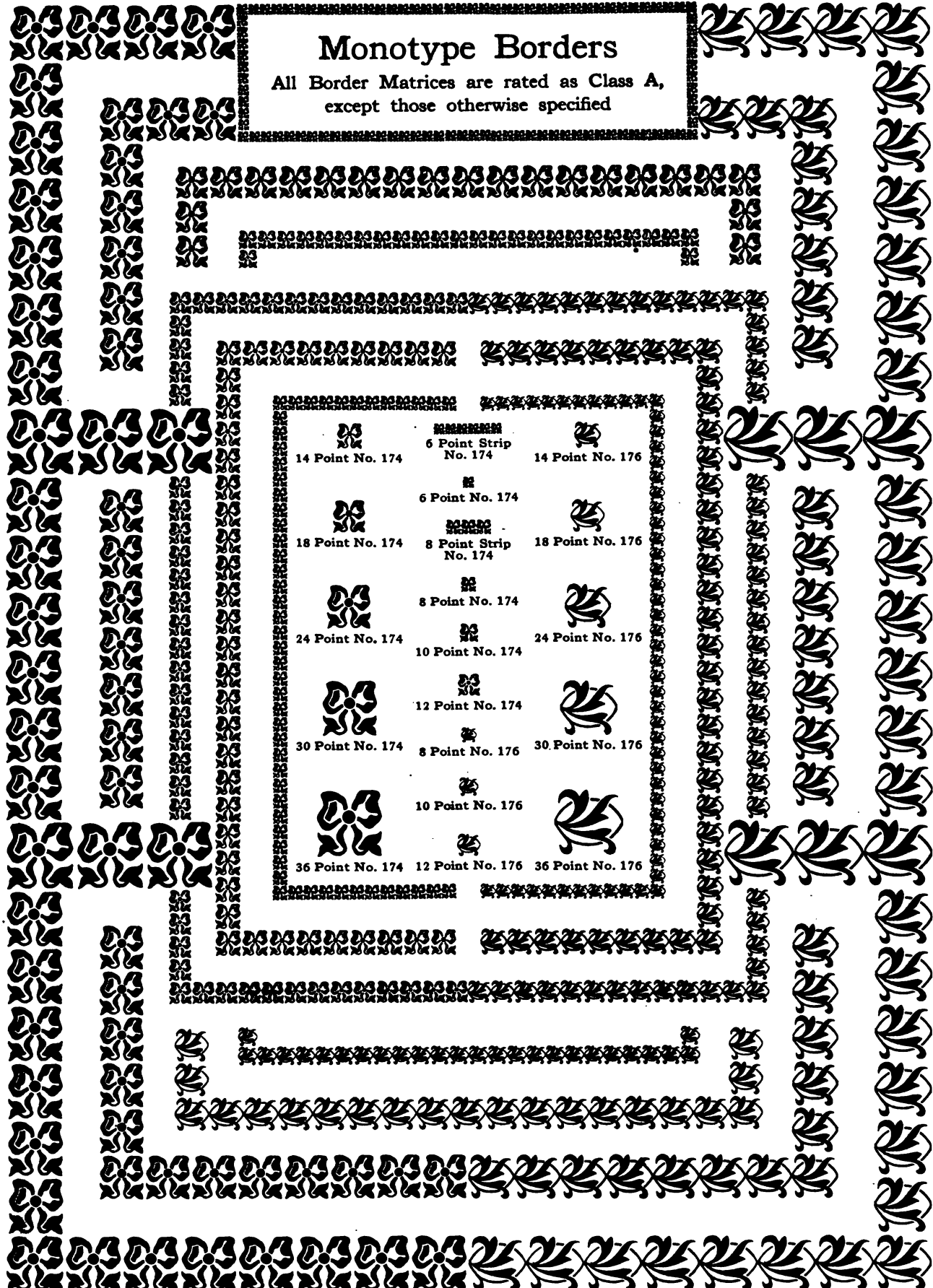

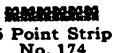





All Border Matrices are rated as Class A,  
except those otherwise specified



# Monotype Borders

All Border Matrices are rated as Class A,  
except those otherwise specified



|   |   |   |
|---|---|---|
| <br>14 Point No. 174   | <br>6 Point Strip<br>No. 174 | <br>14 Point No. 176   |
| <br>18 Point No. 174   | <br>6 Point No. 174          | <br>18 Point No. 176   |
| <br>24 Point No. 174   | <br>8 Point Strip<br>No. 174 | <br>24 Point No. 176   |
| <br>30 Point No. 174  | <br>8 Point No. 174          | <br>30 Point No. 176  |
| <br>36 Point No. 174 | <br>10 Point No. 174         | <br>36 Point No. 176 |
| <br>36 Point No. 174 | <br>12 Point No. 176        | <br>36 Point No. 176 |

# Monotype Borders

All Border Matrices are rated as Class A,  
except those otherwise specified

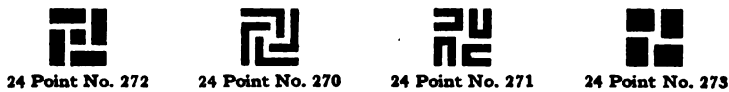
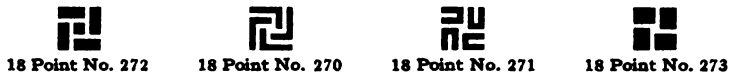

18 Point No. 101



24 Point No. 90

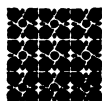
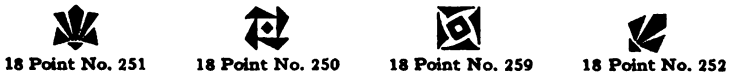
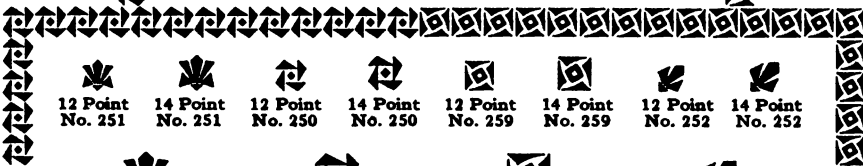

12 Point No. 267































18 Point No. 267

# Monotype Borders

All Border Matrices are rated as Class A,  
except those otherwise specified

**6 Point Strip No. 180**

|  |  |  |
|--|--|--|
|   |   |   |
| 6 Pt. No. 179  | 6 Pt. No. 180  | 6 Pt. No. 181  |
|   |   |   |
| 8 Pt. No. 179  | 8 Pt. No. 180  | 8 Pt. No. 181  |
|   |   |   |
| 10 Pt. No. 179   | 10 Pt. No. 180   | 10 Pt. No. 181   |
|   |   |   |
| 12 Pt. No. 179   | 12 Pt. No. 180   | 12 Pt. No. 181   |
|   |   |   |
| 14 Pt. No. 179   | 14 Pt. No. 180   | 14 Pt. No. 181   |
|   |   |   |
| 18 Pt. No. 179   | 18 Pt. No. 180   | 18 Pt. No. 181   |
|   |   |   |
| 24 Pt. No. 179   | 24 Pt. No. 180   | 24 Pt. No. 181   |
|   |   |   |
| 30 Pt. No. 179   | 30 Pt. No. 180   | 30 Pt. No. 181   |
|  |  |  |
| 36 Pt. No. 179   | 36 Pt. No. 180   | 36 Pt. No. 181   |

# Monotype Borders

All Border Matrices are rated as Class A, except those otherwise specified

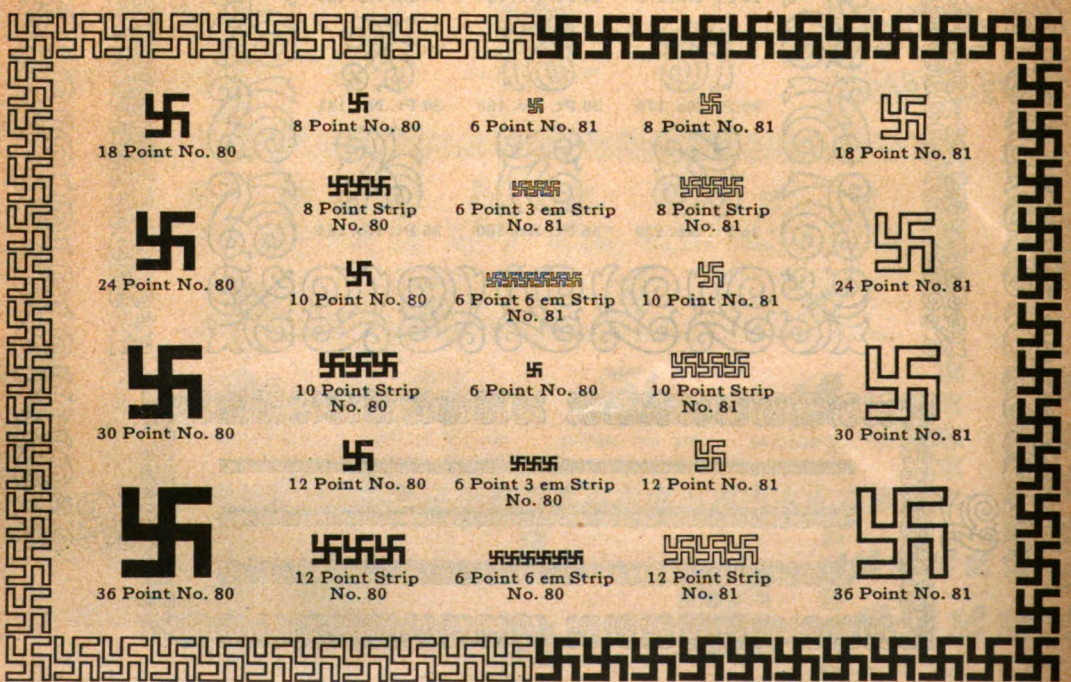
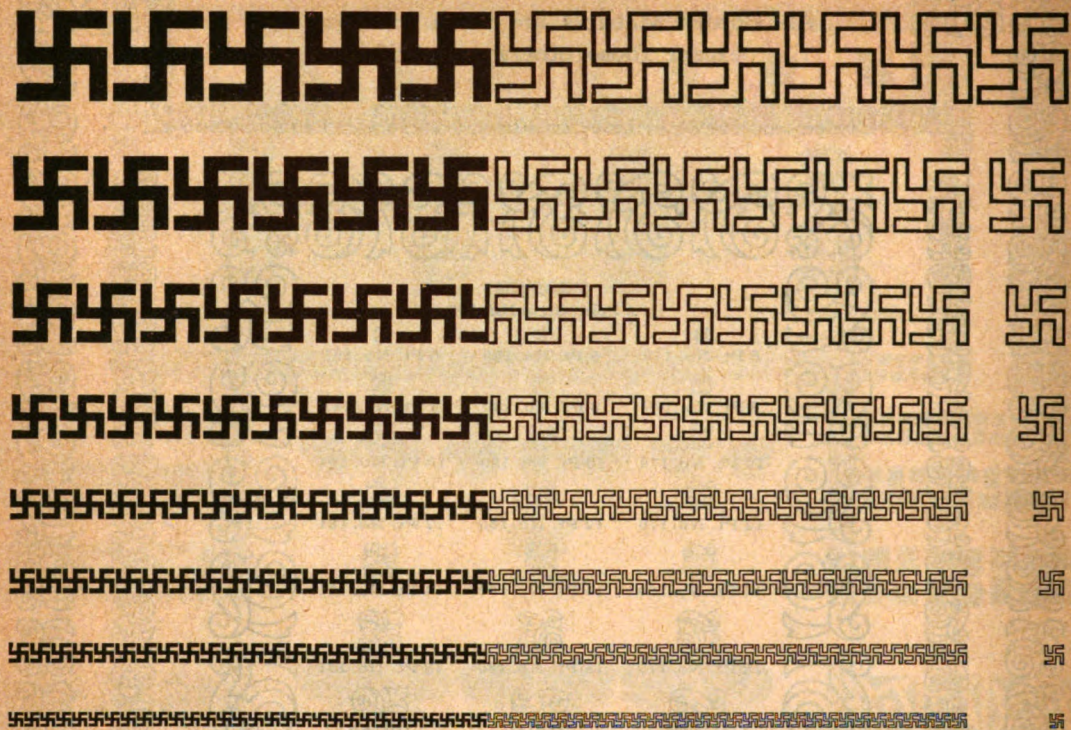

# Monotype Borders

All Border Matrices are rated as Class A,  
except those otherwise specified



12 Point Strip No. 34



6 Point No. 32



8 Point No. 32



14 Point No. 187



12 Point No. 34



10 Point No. 32



12 Point No. 32



18 Point No. 187



12 Point Strip No. 32



18 Point No. 34



18 Point No. 32



24 Point No. 32



24 Point No. 187



24 Point No. 34



36 Point No. 187



30 Point No. 187



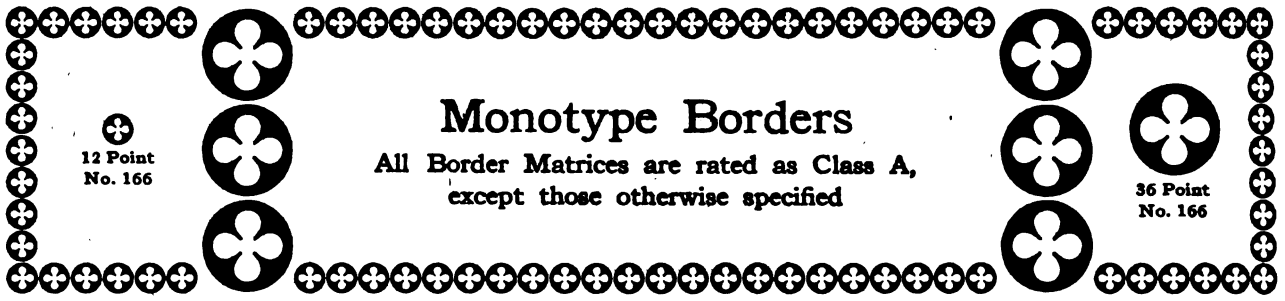

12 Point  
No. 166

# Monotype Borders

All Border Matrices are rated as Class A,  
except those otherwise specified

36 Point  
No. 166

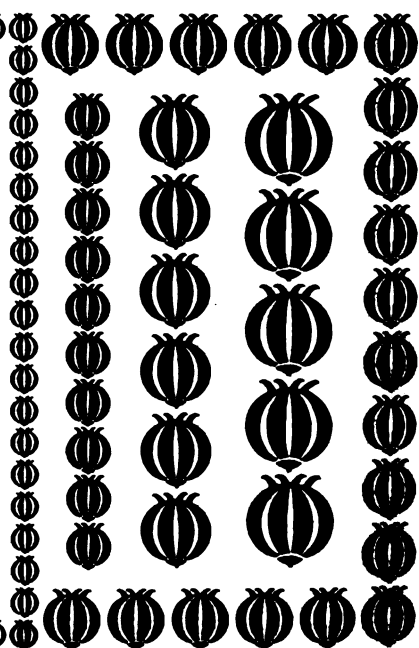
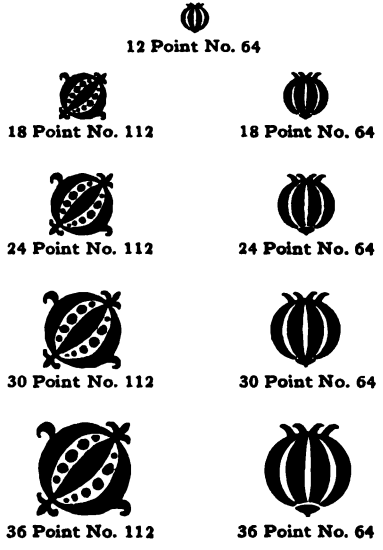
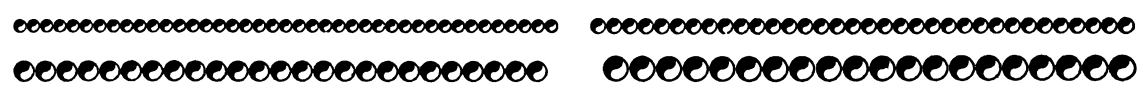
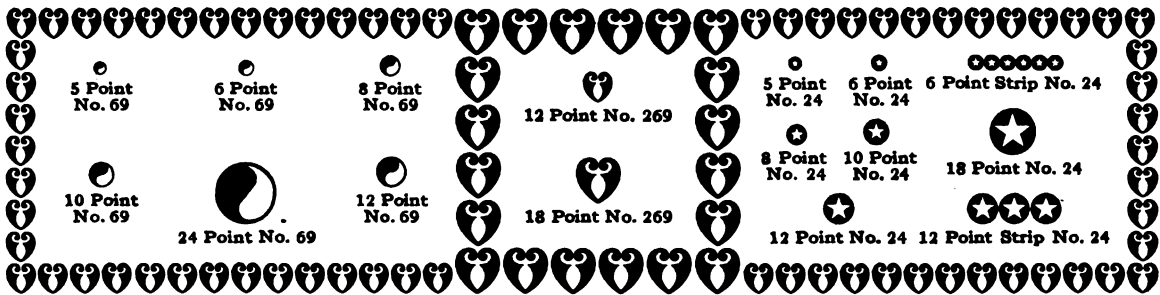

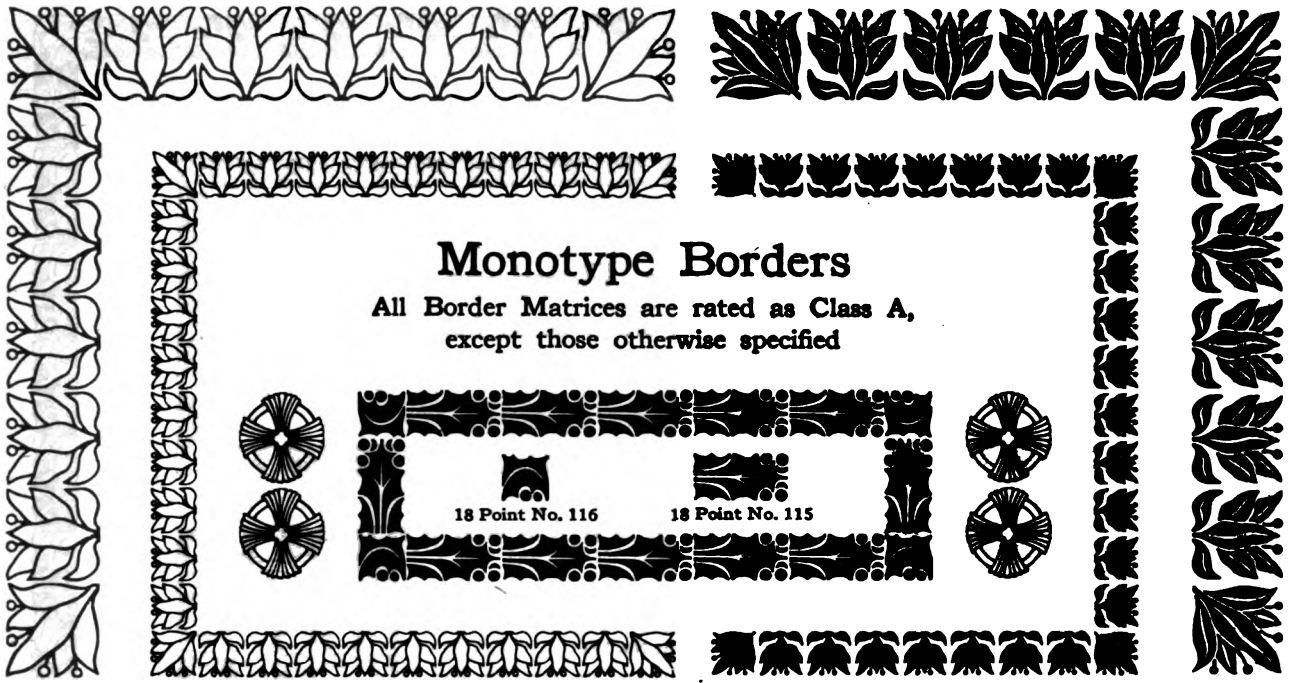

# Monotype Borders

All Border Matrices are rated as Class A,  
except those otherwise specified



18 Point No. 116

18 Point No. 115

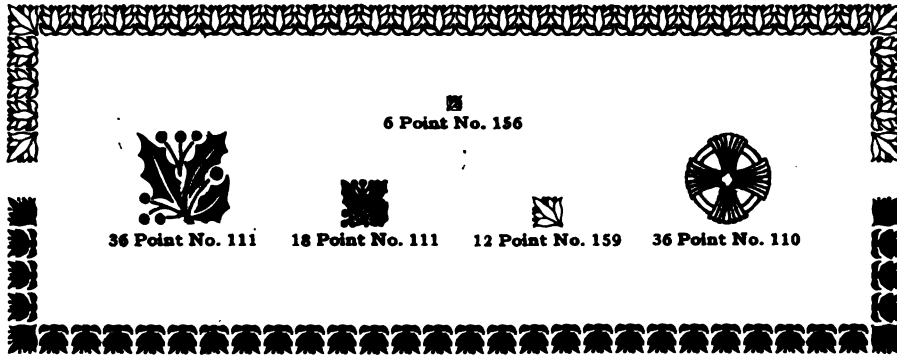

6 Point No. 156

36 Point No. 111

18 Point No. 111

12 Point No. 159

36 Point No. 110

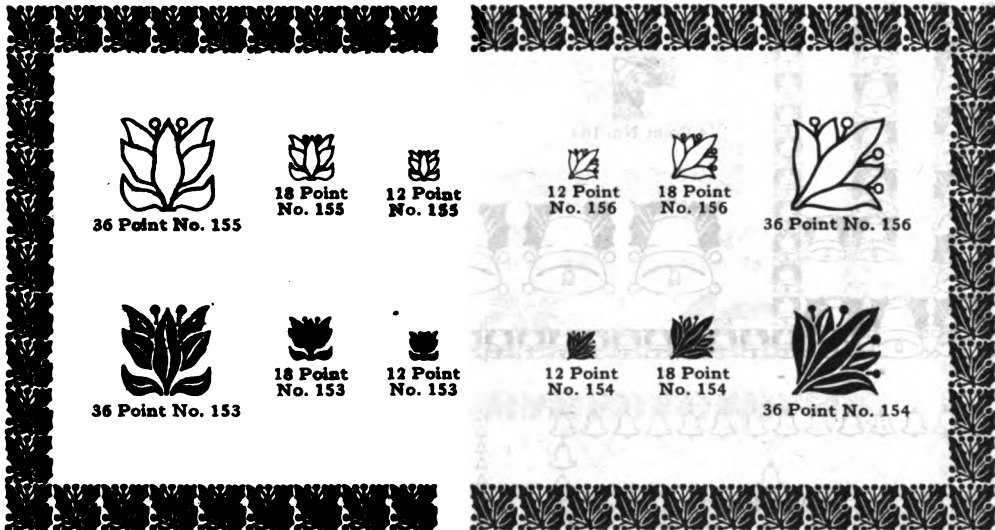

36 Point No. 155

18 Point No. 155

12 Point No. 155

12 Point No. 156

18 Point No. 156

36 Point No. 156

36 Point No. 153

18 Point No. 153

12 Point No. 153

12 Point No. 154

18 Point No. 154

36 Point No. 154





# Monotype Borders

All Border Matrices are rated as Class A,  
except those otherwise specified

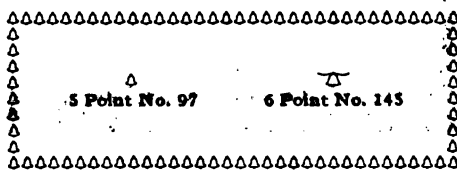
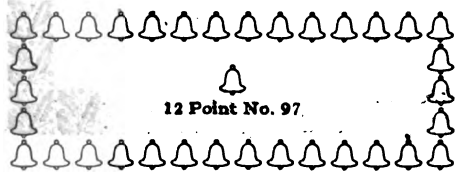
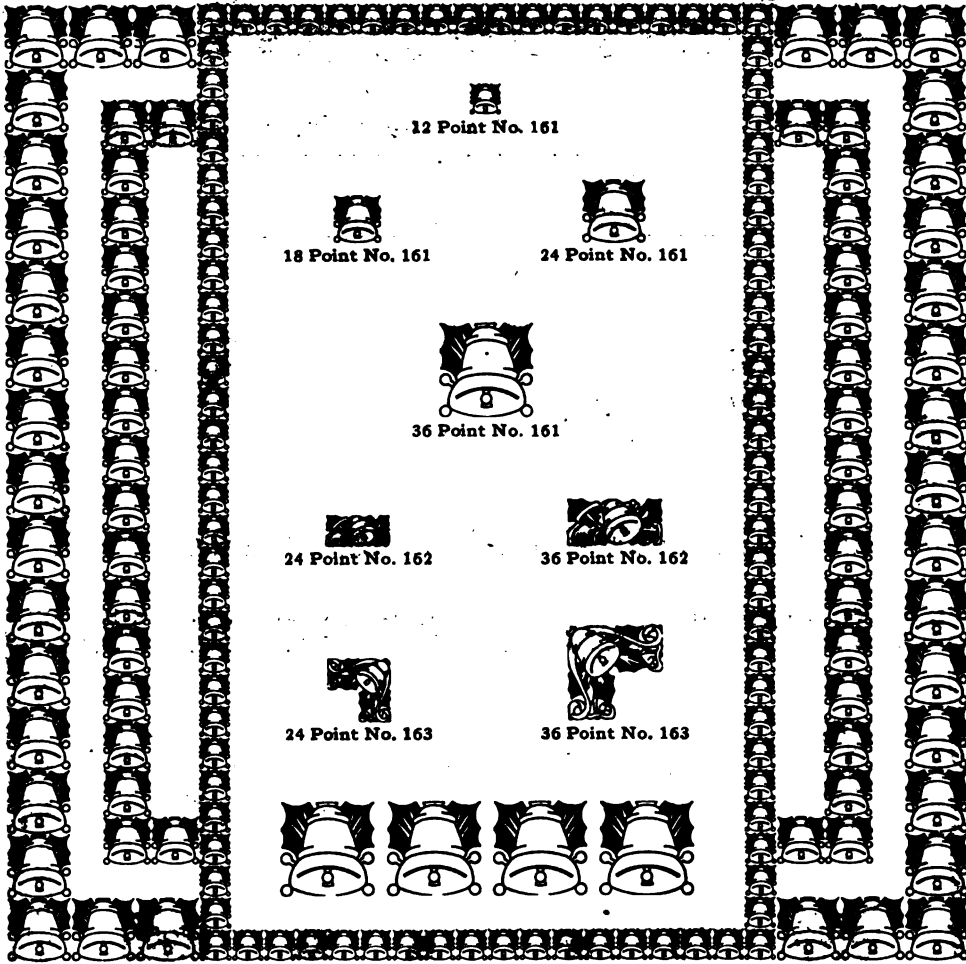



# Monotype Borders

All Border Matrices are rated as Class A,  
except those otherwise specified



18 Point No. 33A



18 Point No. 33B



18 Point No. 33C



24 Point No. 327



24 Point No. 222



36 Point No. 327



36 Point No. 322



24 Point No. 222A



36 Point No. 222A



12 Point No. 328



24 Point No. 329



24 Point No. 330



18 Point No. 328



36 Point No. 329

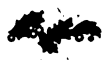

36 Point No. 330

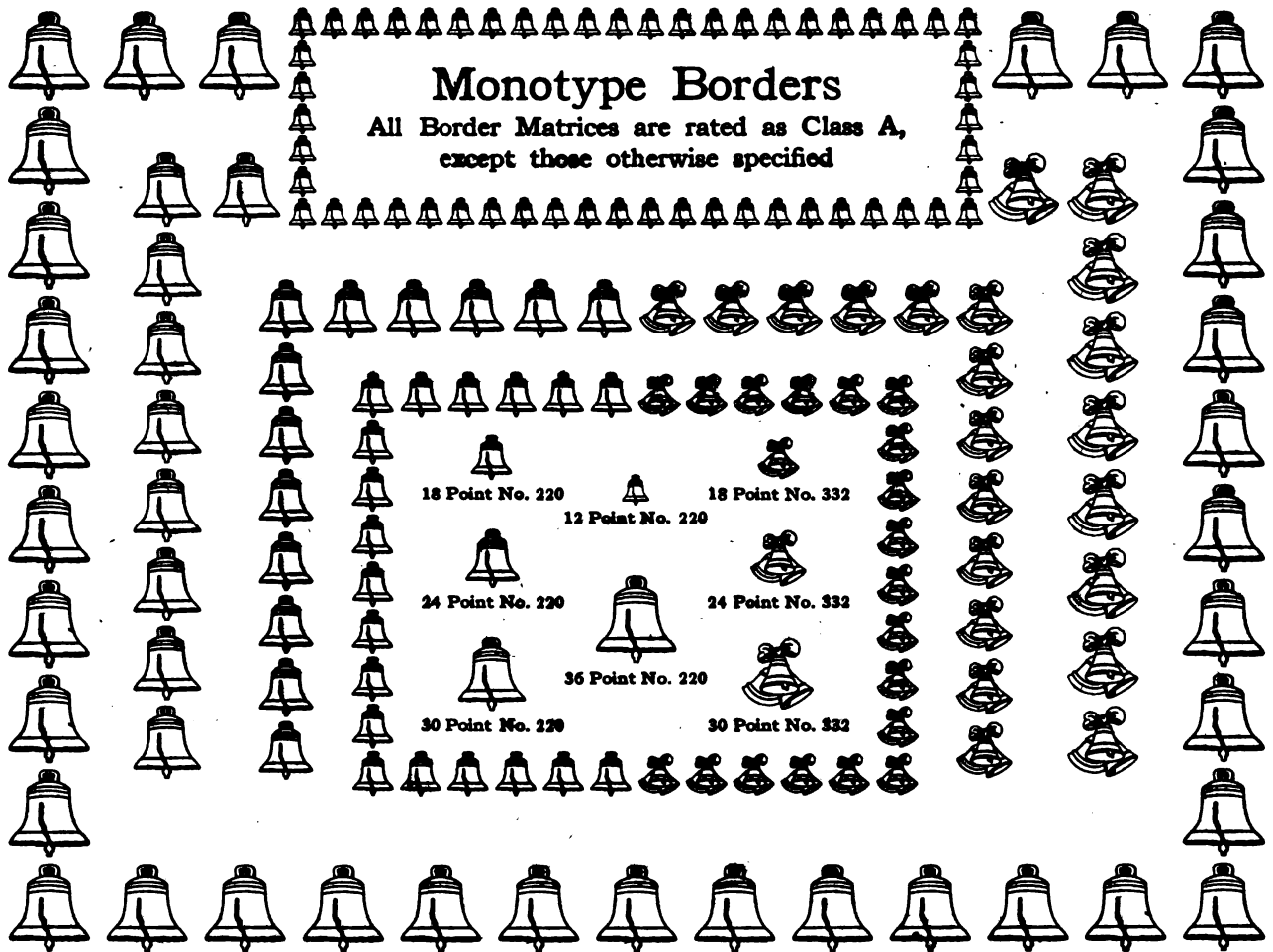

# Monotype Borders

All Border Matrices are rated as Class A,  
except those otherwise specified

18 Point No. 220

12 Point No. 220

18 Point No. 332

24 Point No. 220

24 Point No. 332

36 Point No. 220

30 Point No. 220

30 Point No. 332



18 Point No. 219A

18 Point No. 219B

18 Point No. 219C

18 Point No. 219D

24 Point No. 219A

24 Point No. 219B

24 Point No. 219C

24 Point No. 219D

30 Point No. 219A

30 Point No. 219B

30 Point No. 219C

30 Point No. 219D

# Monotype Borders

All Border Matrices are rated as Class A,  
except those otherwise specified

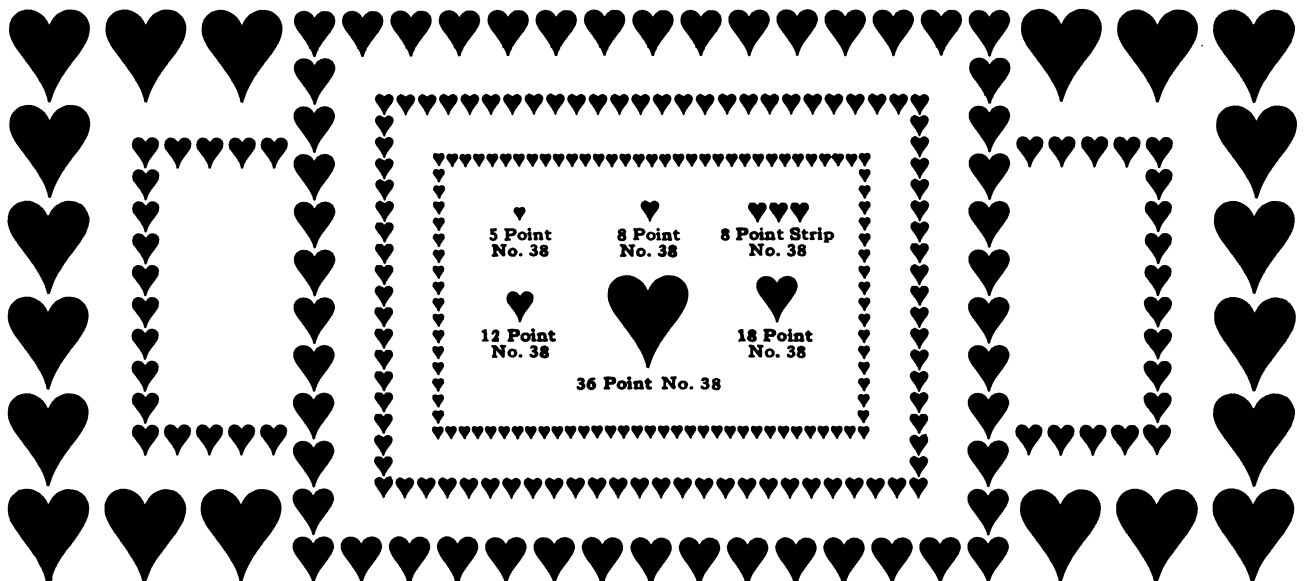
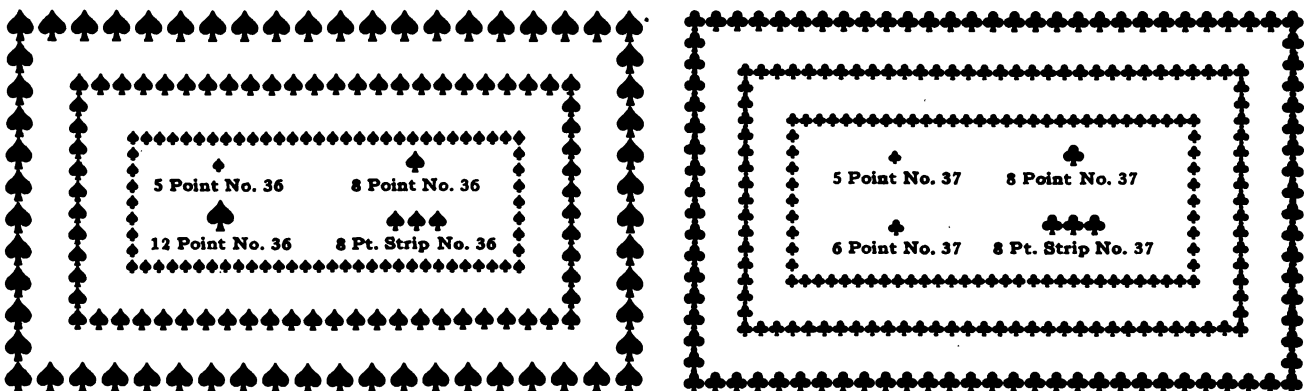
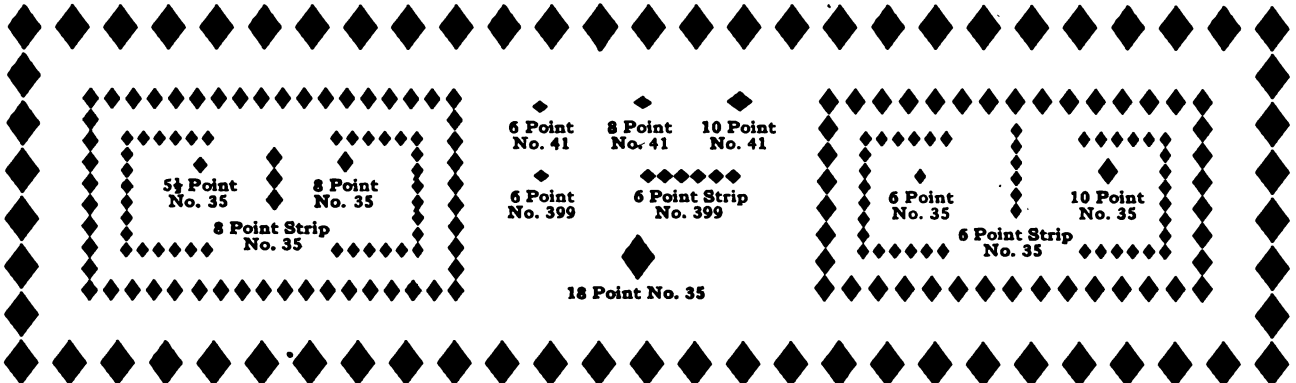
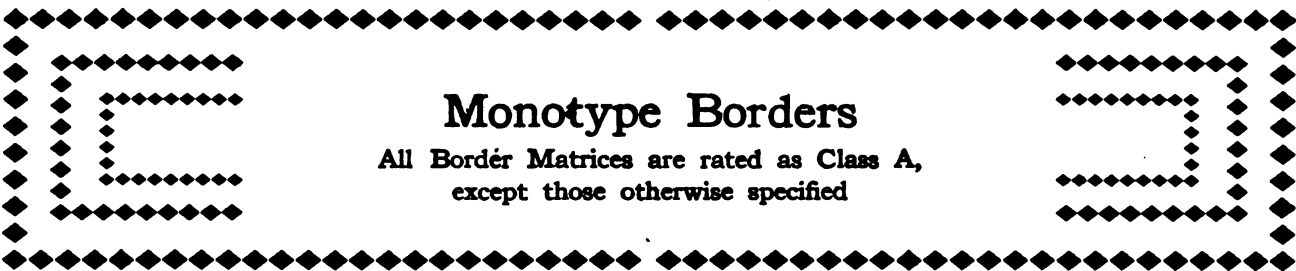

24 Point No. 286

# Monotype Borders

All Border Matrices are rated as Class A,  
except those otherwise specified

24 Point No. 287



24 Point No. 239



36 Point No. 325



24 Point No. 325



24 Point No. 326



36 Point No. 326



24 Point No. 227



18 Point No. 243



18 Point No. 216



18 Point No. 234



18 Point No. 333



30 Point No. 333



18 Point No. 242



30 Point No. 243



30 Point No. 216



24 Point No. 234



36 Point No. 235



30 Point No. 242



14 Point No. 331



18 Point No. 331



24 Point No. 331



24 Point No. 221



30 Point No. 221



36 Point No. 221



18 Point No. 47



18 Point No. 39



24 Point No. 237



36 Point No. 285



24 Point No. 229



24 Point No. 230



24 Point No. 231



24 Point No. 236



24 Point No. 238



24 Point No. 226



18 Point No. 228



24 Point No. 228



30 Point No. 228



24 Point No. 225



36 Point No. 226



36 Point No. 223



24 Point No. 223



24 Point No. 224



36 Point No. 224



36 Point No. 225

# Monotype Borders

All Border Matrices are rated as Class A,  
except those otherwise specified

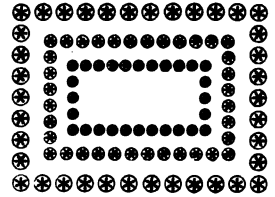
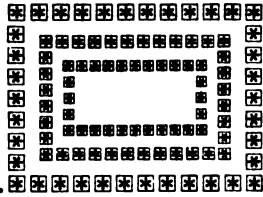

|                         |                         |                 |                         |                         |
|-------------------------|-------------------------|-----------------|-------------------------|-------------------------|
| 5 Point No. 19          | 6 Point No. 11          | 8 Point No. 42  | 6 Point No. 13          | 5 Point No. 20          |
| 6 Point No. 19          | 6 Pt. 3 em Strip No. 11 | 10 Point No. 42 | 6 Pt. 6 em Strip No. 13 | 6 Point No. 20          |
| 6 Pt. 6 em Strip No. 19 | 6 Pt. 6 em Strip No. 11 | 12 Point No. 42 | 8 Point No. 13          | 6 Pt. 6 em Strip No. 20 |
| 6 Pt. 3 em Strip No. 19 | 8 Point No. 11          | 6 Point No. 198 | 6 Point No. 14          | 8 Point No. 20          |
| 8 Point No. 19          | 8 Point No. 44          | 8 Point No. 198 | 8 Point No. 14          | 12 Point No. 87         |

|                     |                 |                  |                     |
|---------------------|-----------------|------------------|---------------------|
| 6 Point Strip No. 5 | 6 Point No. 5   | 12 Point No. 5   | 6 Point Strip No. 6 |
| 6 Point No. 6       | 6 Point No. 12  | 6 Point No. 199  | 6 Point No. 10      |
| 8 Point No. 6       | 8 Point No. 12  | 8 Point No. 199  | 8 Point No. 10      |
| 10 Point No. 6      | 10 Point No. 12 | 10 Point No. 199 | 10 Point No. 10     |
| 12 Point No. 6      | 12 Point No. 12 | 12 Point No. 199 | 12 Point No. 10     |

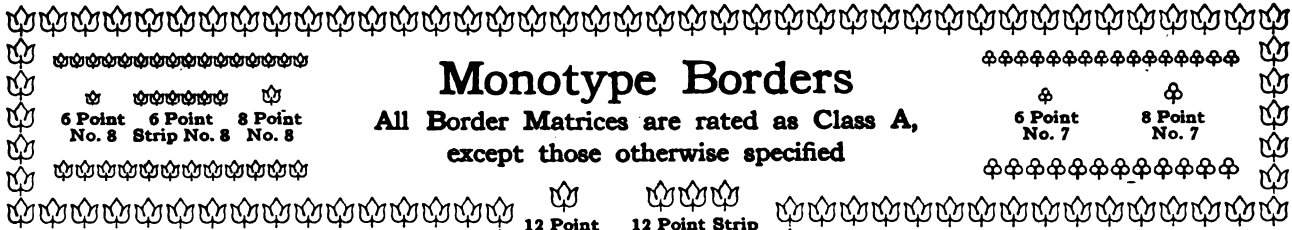

# Monotype Borders

All Border Matrices are rated as Class A,  
except those otherwise specified

6 Point No. 8 Strip No. 8

6 Point No. 7 8 Point No. 7

6 Point No. 7 8 Point No. 7

6 Point No. 7 8 Point No. 7

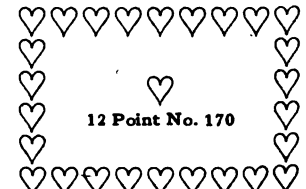
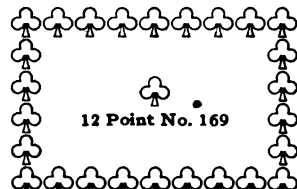
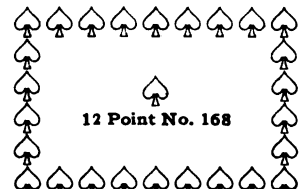
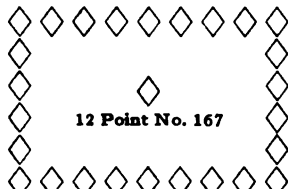
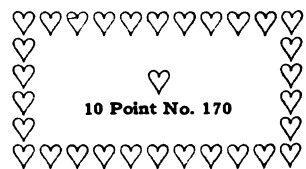
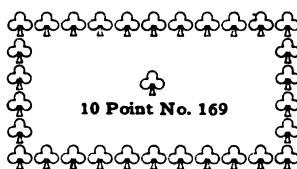
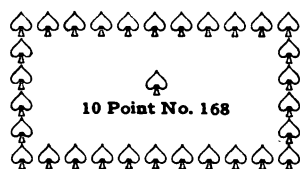
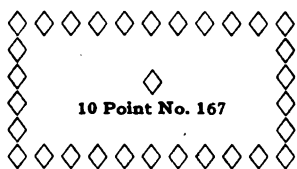
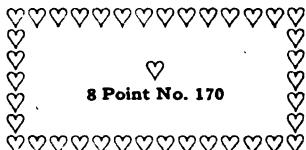
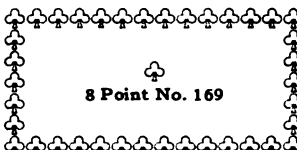
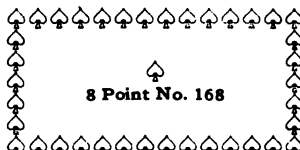
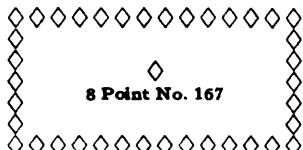
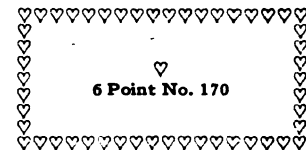
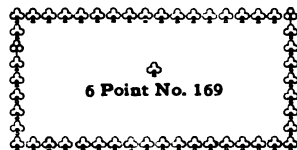
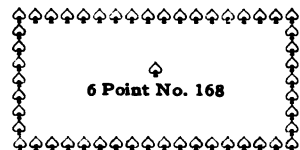
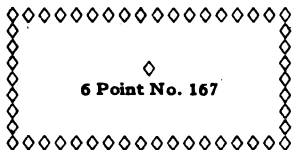
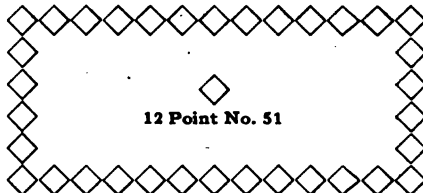
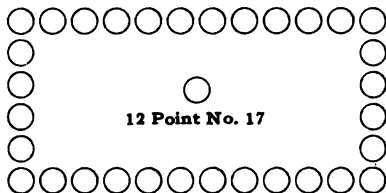
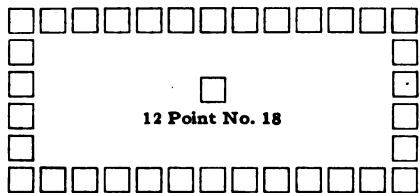
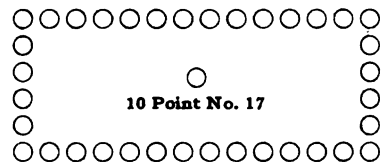
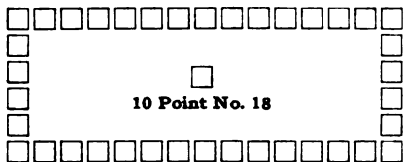
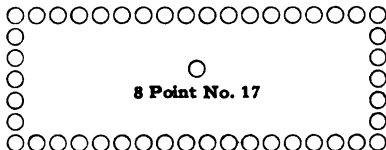
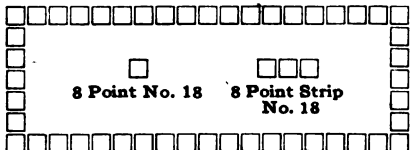
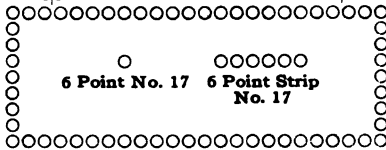
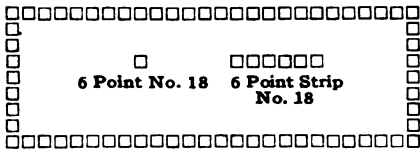

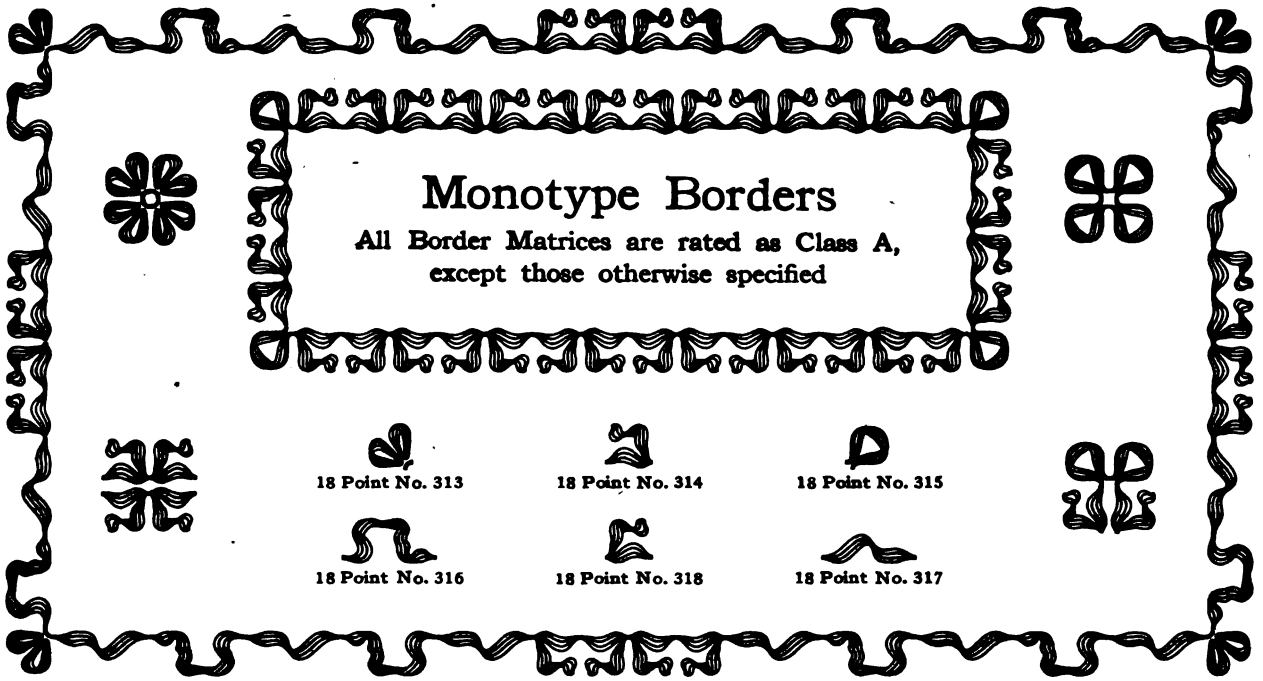

# Monotype Borders

All Border Matrices are rated as Class A,  
except those otherwise specified



18 Point No. 313



18 Point No. 314



18 Point No. 315



18 Point No. 316



18 Point No. 318



18 Point No. 317

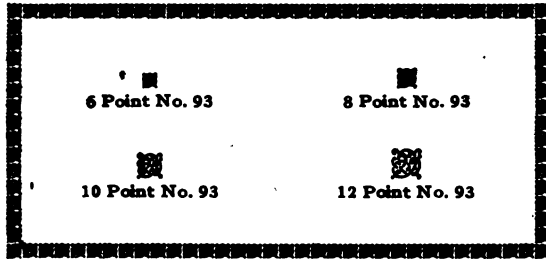
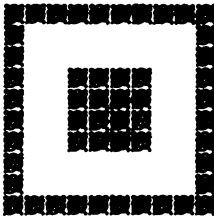
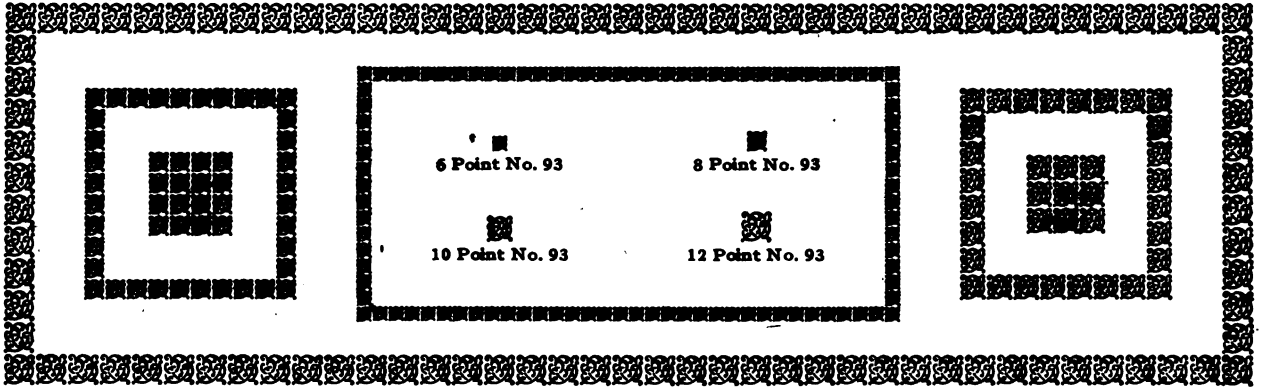

6 Point No. 93

8 Point No. 93

10 Point No. 93

12 Point No. 93

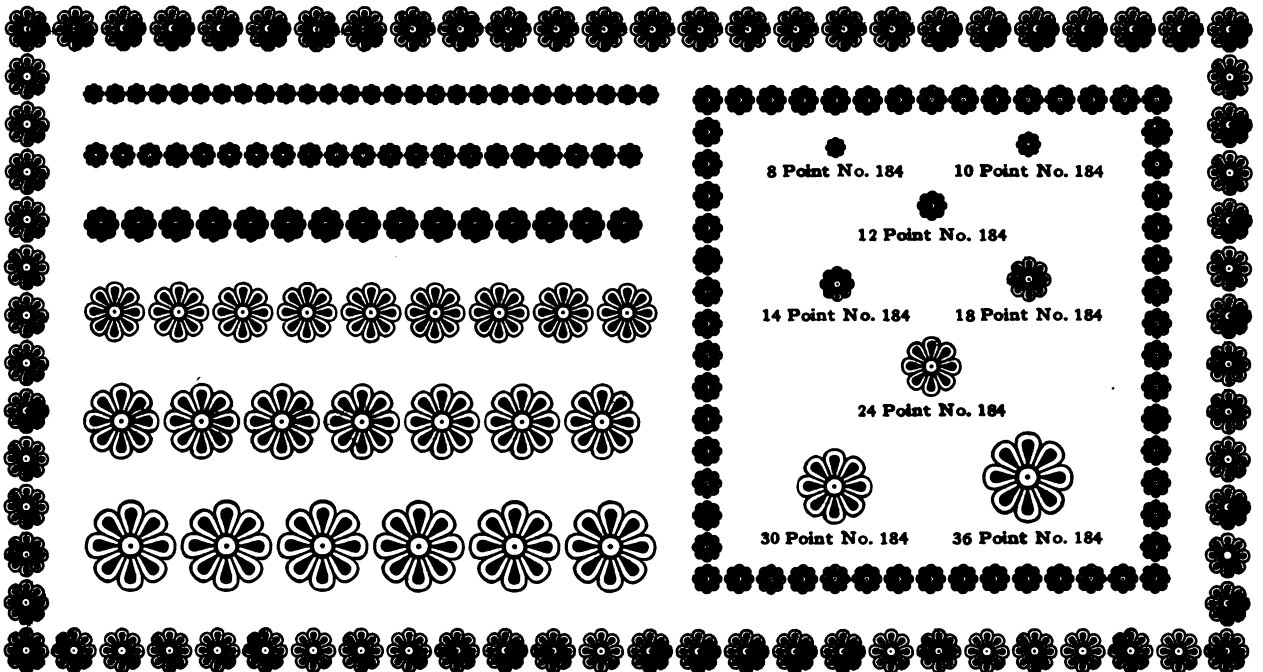

8 Point No. 184

10 Point No. 184

12 Point No. 184

14 Point No. 184

18 Point No. 184

24 Point No. 184

30 Point No. 184

36 Point No. 184





18 Point No. 370

# Monotype Borders

All Border Matrices are rated as Class A,  
except those otherwise specified



36 Point No. 369



6 Point No. 204



6 Point No. 378

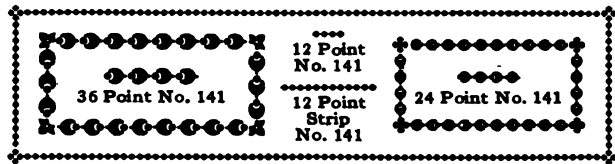

36 Point No. 141

12 Point  
No. 141  
12 Point  
Strip  
No. 141

24 Point No. 141

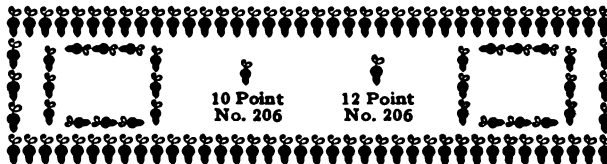

10 Point  
No. 206

12 Point  
No. 206

6 Point No. 137    6 Point No. 133    6 Point No. 135

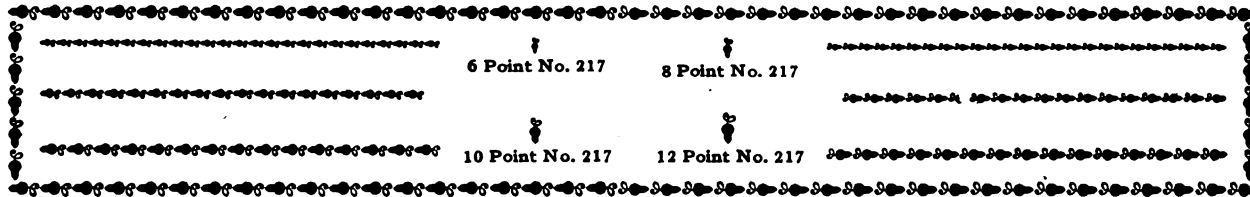

6 Point No. 217

8 Point No. 217

10 Point No. 217

12 Point No. 217

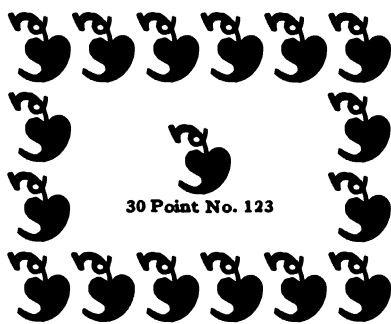

30 Point No. 123

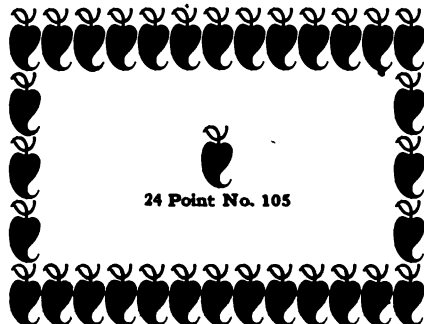

24 Point No. 105

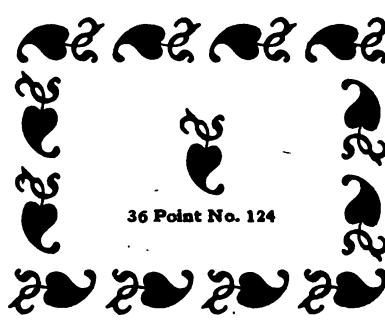

36 Point No. 124

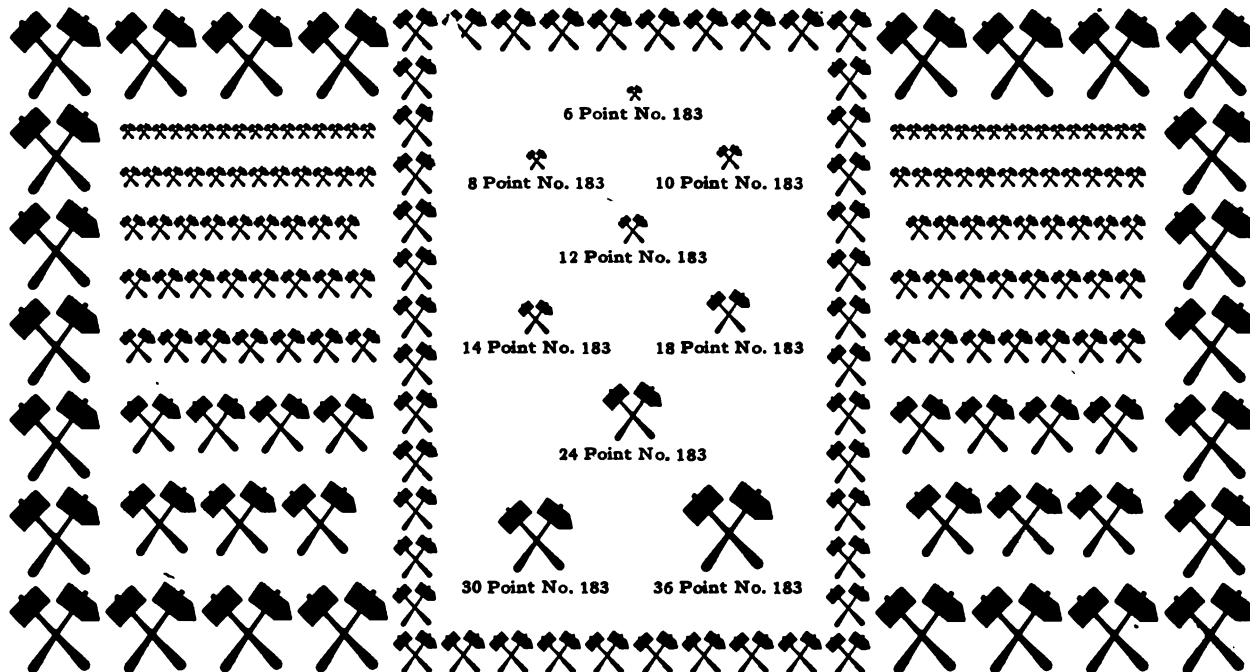

6 Point No. 183

8 Point No. 183

10 Point No. 183

12 Point No. 183

14 Point No. 183

18 Point No. 183

24 Point No. 183

30 Point No. 183

36 Point No. 183

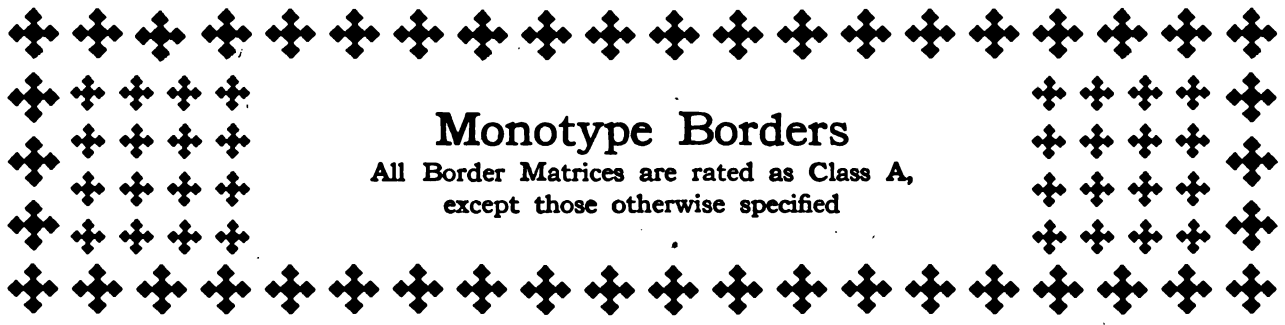

# Monotype Borders

All Border Matrices are rated as Class A,  
except those otherwise specified



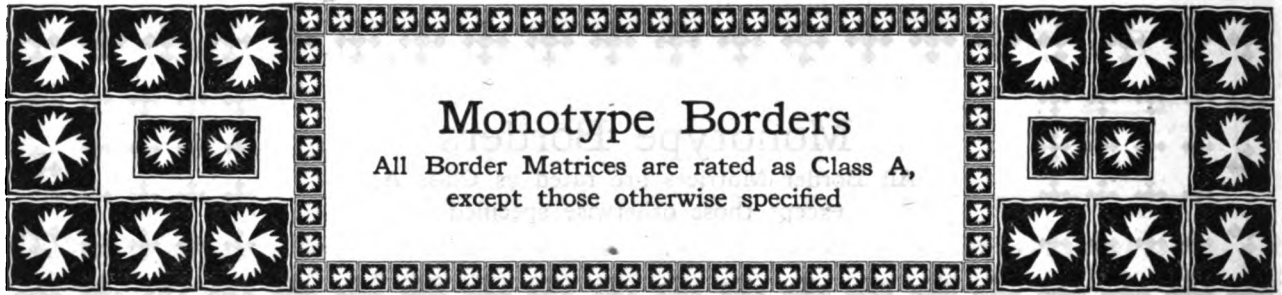





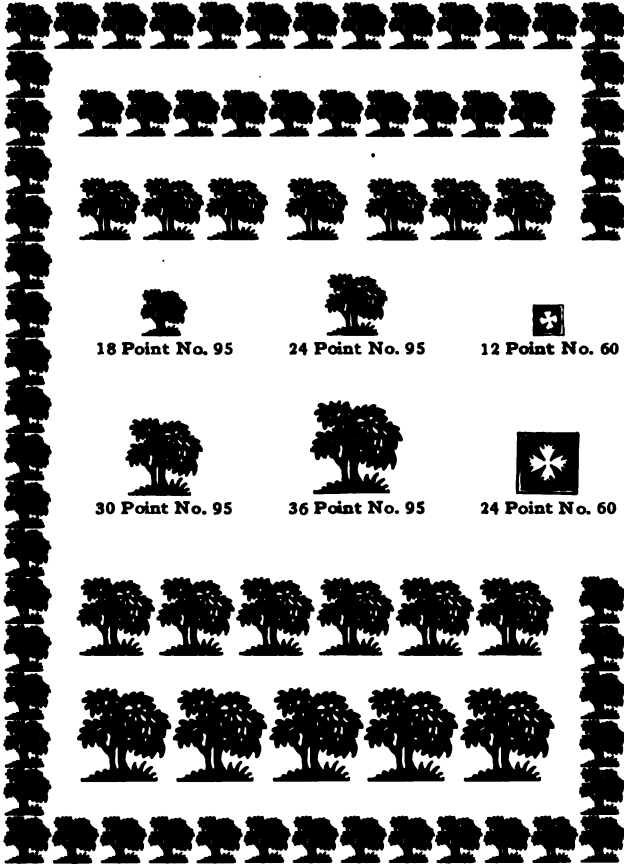



|                      |   |                     |                          |                    |                     |                     |                     |                     |                      |  |  |                      |                      |  |  |                    |                        |  |  |                    |                    |  |  |                    |                    |  |  |                    |                    |  |  |                     |                     |  |  |                     |                     |  |  |                     |                     |  |  |                     |                     |  |  |                     |                     |  |  |                     |                     |  |  |  |
|----------------------|---|---------------------|--------------------------|--------------------|---------------------|---------------------|---------------------|---------------------|----------------------|--|--|----------------------|----------------------|--|--|--------------------|------------------------|--|--|--------------------|--------------------|--|--|--------------------|--------------------|--|--|--------------------|--------------------|--|--|---------------------|---------------------|--|--|---------------------|---------------------|--|--|---------------------|---------------------|--|--|---------------------|---------------------|--|--|---------------------|---------------------|--|--|---------------------|---------------------|--|--|--|
|                      | <table border="0"> <tr> <td style="text-align: center;"> <br/>           6 Point No. 23         </td> <td style="text-align: center;"> <br/>           6 Point Strip No. 23         </td> </tr> <tr> <td style="text-align: center;"> <br/>           8 Point No. 23         </td> <td style="text-align: center;"> <br/>           10 Point No. 23         </td> <td style="text-align: center;"> <br/>           11 Point No. 23         </td> <td style="text-align: center;"> <br/>           12 Point No. 23         </td> </tr> <tr> <td style="text-align: center;"> <br/>           8 Point No. 164         </td> <td colspan="3" style="text-align: center;"> <br/>           12 Point No. 171         </td> </tr> <tr> <td style="text-align: center;"> <br/>           18 Point No. 149         </td> <td colspan="3" style="text-align: center;"> <br/>           24 Point No. 149         </td> </tr> <tr> <td style="text-align: center;"> <br/>           5 Point No. 40         </td> <td colspan="3" style="text-align: center;"> <br/>           5 1/2 Point No. 40         </td> </tr> <tr> <td style="text-align: center;"> <br/>           5 Point No. 66         </td> <td colspan="3" style="text-align: center;"> <br/>           6 Point No. 40         </td> </tr> <tr> <td style="text-align: center;"> <br/>           6 Point No. 66         </td> <td colspan="3" style="text-align: center;"> <br/>           7 Point No. 40         </td> </tr> <tr> <td style="text-align: center;"> <br/>           8 Point No. 66         </td> <td colspan="3" style="text-align: center;"> <br/>           8 Point No. 40         </td> </tr> <tr> <td style="text-align: center;"> <br/>           10 Point No. 66         </td> <td colspan="3" style="text-align: center;"> <br/>           10 Point No. 40         </td> </tr> <tr> <td style="text-align: center;"> <br/>           12 Point No. 66         </td> <td colspan="3" style="text-align: center;"> <br/>           12 Point No. 40         </td> </tr> <tr> <td style="text-align: center;"> <br/>           18 Point No. 66         </td> <td colspan="3" style="text-align: center;"> <br/>           18 Point No. 40         </td> </tr> <tr> <td style="text-align: center;"> <br/>           24 Point No. 66         </td> <td colspan="3" style="text-align: center;"> <br/>           24 Point No. 40         </td> </tr> <tr> <td style="text-align: center;"> <br/>           30 Point No. 66         </td> <td colspan="3" style="text-align: center;"> <br/>           30 Point No. 40         </td> </tr> <tr> <td style="text-align: center;"> <br/>           36 Point No. 66         </td> <td colspan="3" style="text-align: center;"> <br/>           36 Point No. 40         </td> </tr> </table> | <br>6 Point No. 23  | <br>6 Point Strip No. 23 | <br>8 Point No. 23 | <br>10 Point No. 23 | <br>11 Point No. 23 | <br>12 Point No. 23 | <br>8 Point No. 164 | <br>12 Point No. 171 |  |  | <br>18 Point No. 149 | <br>24 Point No. 149 |  |  | <br>5 Point No. 40 | <br>5 1/2 Point No. 40 |  |  | <br>5 Point No. 66 | <br>6 Point No. 40 |  |  | <br>6 Point No. 66 | <br>7 Point No. 40 |  |  | <br>8 Point No. 66 | <br>8 Point No. 40 |  |  | <br>10 Point No. 66 | <br>10 Point No. 40 |  |  | <br>12 Point No. 66 | <br>12 Point No. 40 |  |  | <br>18 Point No. 66 | <br>18 Point No. 40 |  |  | <br>24 Point No. 66 | <br>24 Point No. 40 |  |  | <br>30 Point No. 66 | <br>30 Point No. 40 |  |  | <br>36 Point No. 66 | <br>36 Point No. 40 |  |  |  |
| <br>6 Point No. 23   | <br>6 Point Strip No. 23  |                     |                          |                    |                     |                     |                     |                     |                      |  |  |                      |                      |  |  |                    |                        |  |  |                    |                    |  |  |                    |                    |  |  |                    |                    |  |  |                     |                     |  |  |                     |                     |  |  |                     |                     |  |  |                     |                     |  |  |                     |                     |  |  |                     |                     |  |  |  |
| <br>8 Point No. 23   | <br>10 Point No. 23   | <br>11 Point No. 23 | <br>12 Point No. 23      |                    |                     |                     |                     |                     |                      |  |  |                      |                      |  |  |                    |                        |  |  |                    |                    |  |  |                    |                    |  |  |                    |                    |  |  |                     |                     |  |  |                     |                     |  |  |                     |                     |  |  |                     |                     |  |  |                     |                     |  |  |                     |                     |  |  |  |
| <br>8 Point No. 164  | <br>12 Point No. 171  |                     |                          |                    |                     |                     |                     |                     |                      |  |  |                      |                      |  |  |                    |                        |  |  |                    |                    |  |  |                    |                    |  |  |                    |                    |  |  |                     |                     |  |  |                     |                     |  |  |                     |                     |  |  |                     |                     |  |  |                     |                     |  |  |                     |                     |  |  |  |
| <br>18 Point No. 149 | <br>24 Point No. 149  |                     |                          |                    |                     |                     |                     |                     |                      |  |  |                      |                      |  |  |                    |                        |  |  |                    |                    |  |  |                    |                    |  |  |                    |                    |  |  |                     |                     |  |  |                     |                     |  |  |                     |                     |  |  |                     |                     |  |  |                     |                     |  |  |                     |                     |  |  |  |
| <br>5 Point No. 40   | <br>5 1/2 Point No. 40  |                     |                          |                    |                     |                     |                     |                     |                      |  |  |                      |                      |  |  |                    |                        |  |  |                    |                    |  |  |                    |                    |  |  |                    |                    |  |  |                     |                     |  |  |                     |                     |  |  |                     |                     |  |  |                     |                     |  |  |                     |                     |  |  |                     |                     |  |  |  |
| <br>5 Point No. 66   | <br>6 Point No. 40  |                     |                          |                    |                     |                     |                     |                     |                      |  |  |                      |                      |  |  |                    |                        |  |  |                    |                    |  |  |                    |                    |  |  |                    |                    |  |  |                     |                     |  |  |                     |                     |  |  |                     |                     |  |  |                     |                     |  |  |                     |                     |  |  |                     |                     |  |  |  |
| <br>6 Point No. 66   | <br>7 Point No. 40  |                     |                          |                    |                     |                     |                     |                     |                      |  |  |                      |                      |  |  |                    |                        |  |  |                    |                    |  |  |                    |                    |  |  |                    |                    |  |  |                     |                     |  |  |                     |                     |  |  |                     |                     |  |  |                     |                     |  |  |                     |                     |  |  |                     |                     |  |  |  |
| <br>8 Point No. 66   | <br>8 Point No. 40  |                     |                          |                    |                     |                     |                     |                     |                      |  |  |                      |                      |  |  |                    |                        |  |  |                    |                    |  |  |                    |                    |  |  |                    |                    |  |  |                     |                     |  |  |                     |                     |  |  |                     |                     |  |  |                     |                     |  |  |                     |                     |  |  |                     |                     |  |  |  |
| <br>10 Point No. 66  | <br>10 Point No. 40   |                     |                          |                    |                     |                     |                     |                     |                      |  |  |                      |                      |  |  |                    |                        |  |  |                    |                    |  |  |                    |                    |  |  |                    |                    |  |  |                     |                     |  |  |                     |                     |  |  |                     |                     |  |  |                     |                     |  |  |                     |                     |  |  |                     |                     |  |  |  |
| <br>12 Point No. 66  | <br>12 Point No. 40   |                     |                          |                    |                     |                     |                     |                     |                      |  |  |                      |                      |  |  |                    |                        |  |  |                    |                    |  |  |                    |                    |  |  |                    |                    |  |  |                     |                     |  |  |                     |                     |  |  |                     |                     |  |  |                     |                     |  |  |                     |                     |  |  |                     |                     |  |  |  |
| <br>18 Point No. 66  | <br>18 Point No. 40   |                     |                          |                    |                     |                     |                     |                     |                      |  |  |                      |                      |  |  |                    |                        |  |  |                    |                    |  |  |                    |                    |  |  |                    |                    |  |  |                     |                     |  |  |                     |                     |  |  |                     |                     |  |  |                     |                     |  |  |                     |                     |  |  |                     |                     |  |  |  |
| <br>24 Point No. 66  | <br>24 Point No. 40   |                     |                          |                    |                     |                     |                     |                     |                      |  |  |                      |                      |  |  |                    |                        |  |  |                    |                    |  |  |                    |                    |  |  |                    |                    |  |  |                     |                     |  |  |                     |                     |  |  |                     |                     |  |  |                     |                     |  |  |                     |                     |  |  |                     |                     |  |  |  |
| <br>30 Point No. 66  | <br>30 Point No. 40   |                     |                          |                    |                     |                     |                     |                     |                      |  |  |                      |                      |  |  |                    |                        |  |  |                    |                    |  |  |                    |                    |  |  |                    |                    |  |  |                     |                     |  |  |                     |                     |  |  |                     |                     |  |  |                     |                     |  |  |                     |                     |  |  |                     |                     |  |  |  |
| <br>36 Point No. 66  | <br>36 Point No. 40   |                     |                          |                    |                     |                     |                     |                     |                      |  |  |                      |                      |  |  |                    |                        |  |  |                    |                    |  |  |                    |                    |  |  |                    |                    |  |  |                     |                     |  |  |                     |                     |  |  |                     |                     |  |  |                     |                     |  |  |                     |                     |  |  |                     |                     |  |  |  |







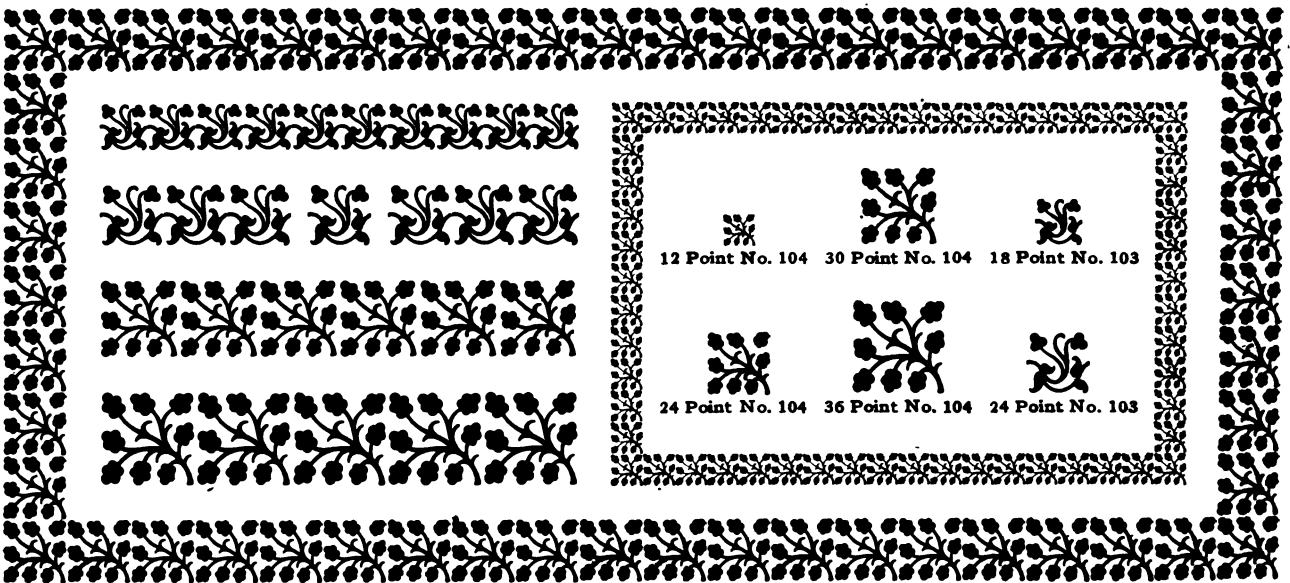
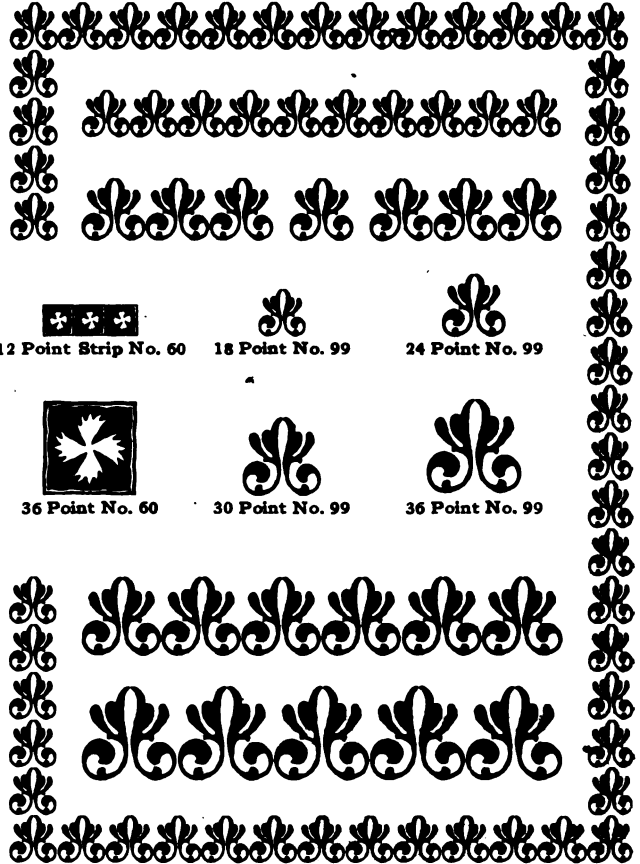

# Monotype Borders

All Border Matrices are rated as Class A,  
except those otherwise specified



- |   |   |   |   |  |   |
|---|---|---|---|--|---|
|  |  |  |  |  |  |
| 18 Point No. 95   | 24 Point No. 95   | 12 Point No. 60   | 12 Point Strip No. 60   | 18 Point No. 99  | 24 Point No. 99   |
|  |  |  |  |  |  |
| 30 Point No. 95   | 36 Point No. 95   | 24 Point No. 60   | 36 Point No. 60   | 30 Point No. 99  | 36 Point No. 99   |



- |   |  |   |
|---|--|---|
|  |  |  |
| 12 Point No. 104  | 30 Point No. 104   | 18 Point No. 103  |
|  |  |  |
| 24 Point No. 104  | 36 Point No. 104   | 24 Point No. 103  |

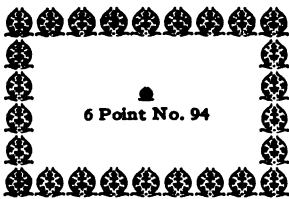

6 Point No. 94

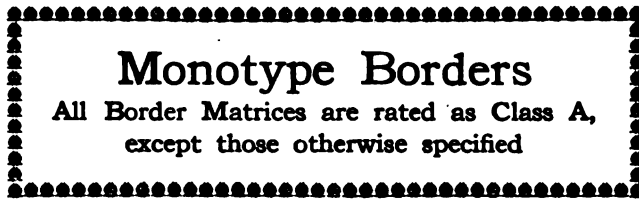

# Monotype Borders

All Border Matrices are rated as Class A,  
except those otherwise specified



12 Point No. 94

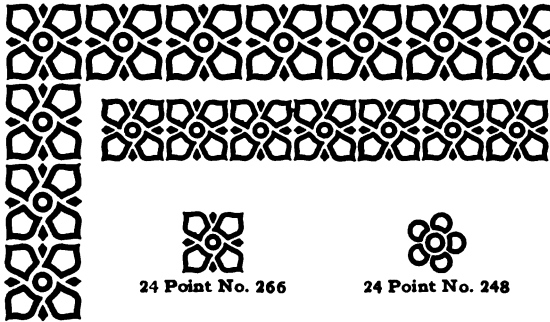

24 Point No. 266



24 Point No. 248

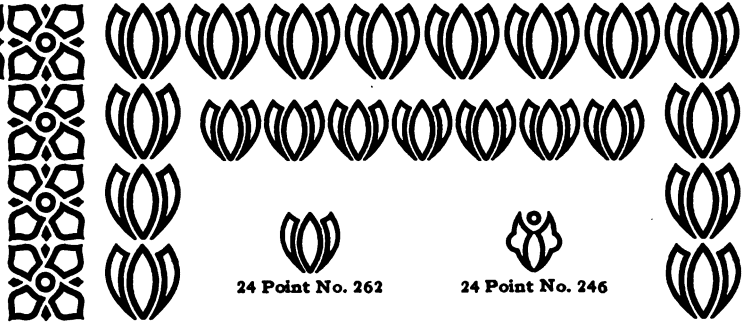

24 Point No. 262



24 Point No. 246

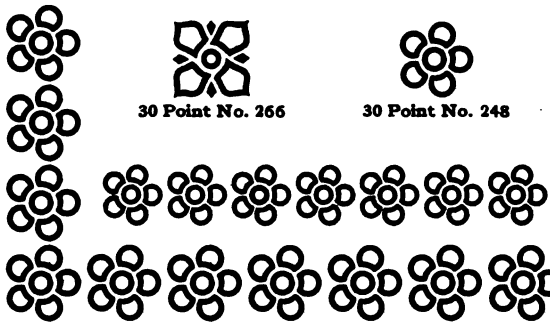

30 Point No. 266

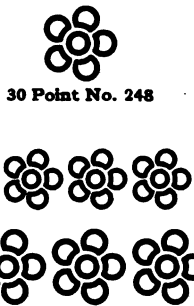

30 Point No. 248

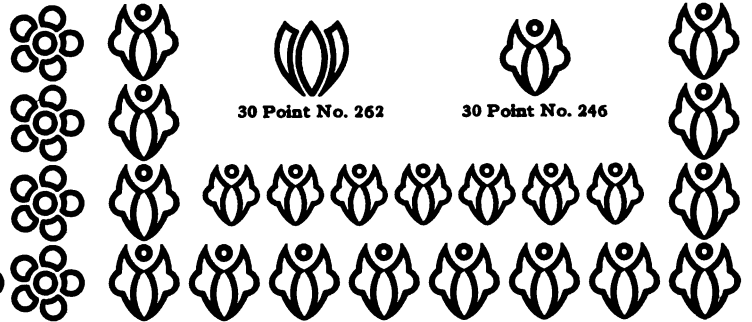

30 Point No. 262

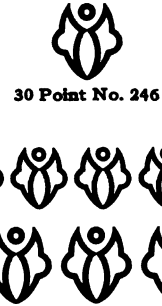

30 Point No. 246

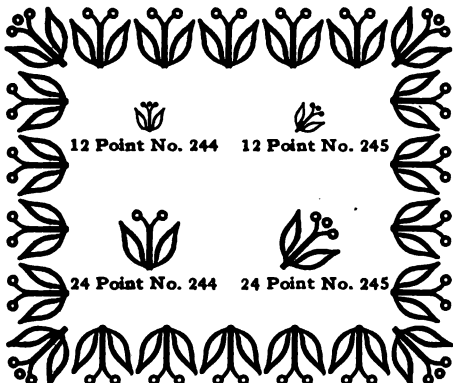

12 Point No. 244 12 Point No. 245



24 Point No. 244 24 Point No. 245



18 Point No. 67

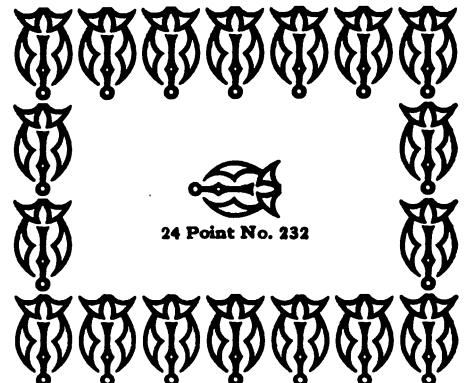

24 Point No. 232

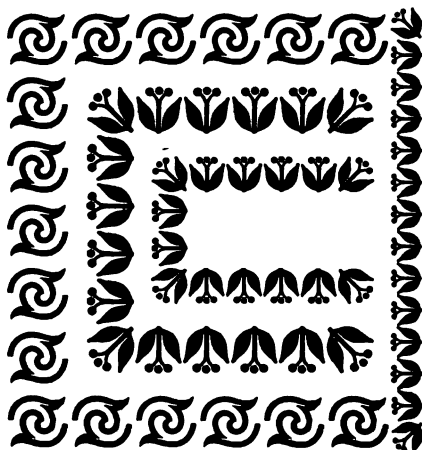

12 Point No. 253

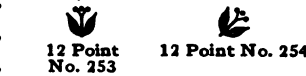

12 Point No. 254



12 Point No. 256



14 Point No. 253

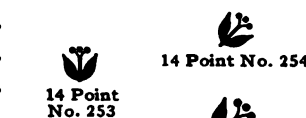

14 Point No. 254



14 Point No. 256



18 Point No. 253

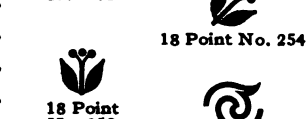

18 Point No. 254



18 Point No. 256



24 Point No. 253



24 Point No. 256



24 Point No. 256

# Monotype Borders

All Border Matrices are rated as Class A, except those otherwise specified

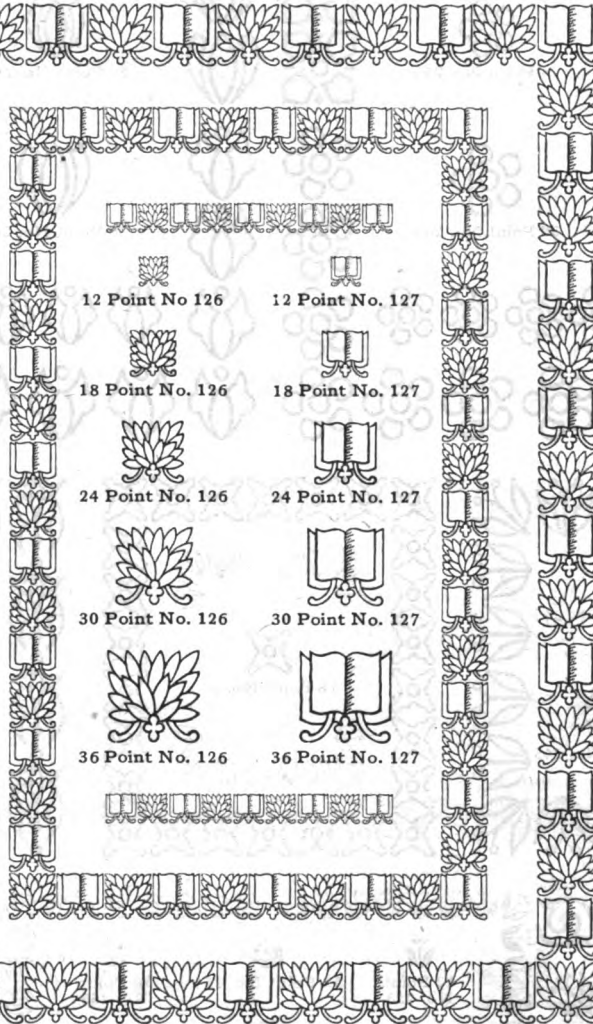
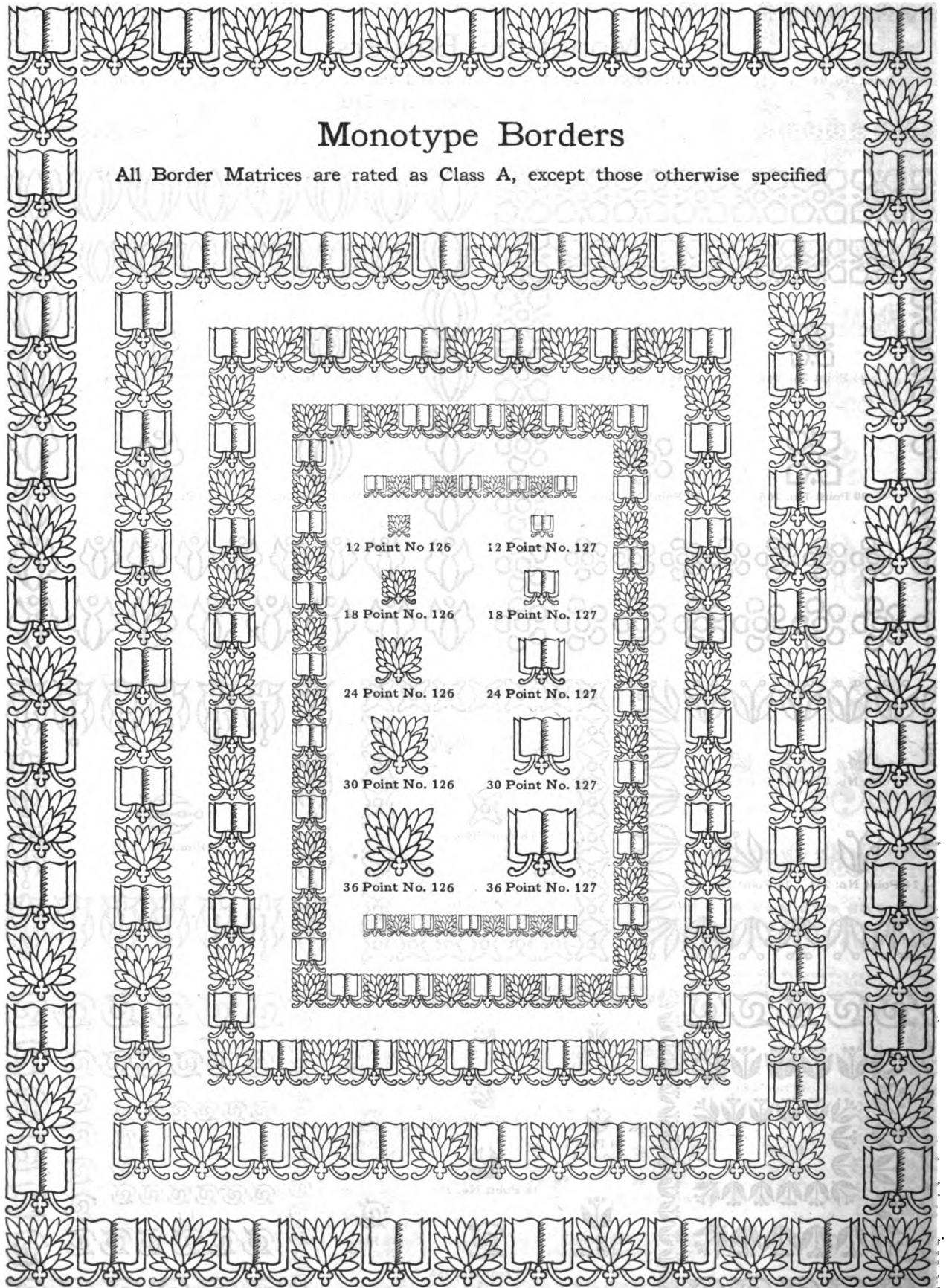

12 Point No. 126

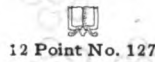

12 Point No. 127



18 Point No. 126



18 Point No. 127



24 Point No. 126



24 Point No. 127



30 Point No. 126



30 Point No. 127



36 Point No. 126



36 Point No. 127



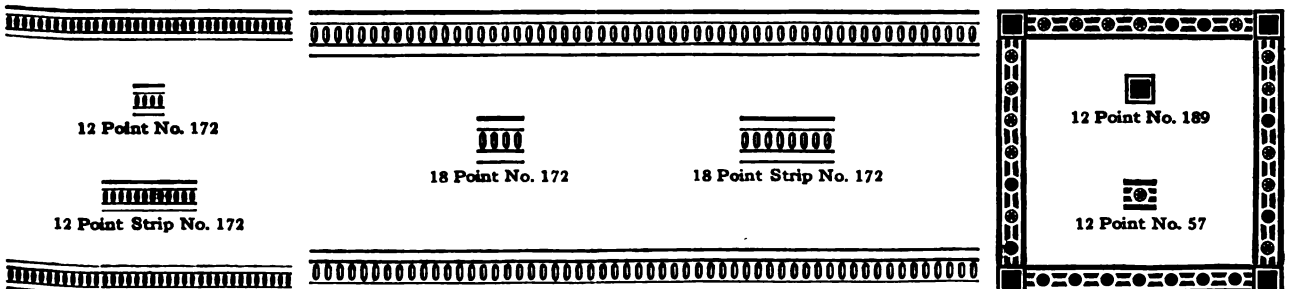
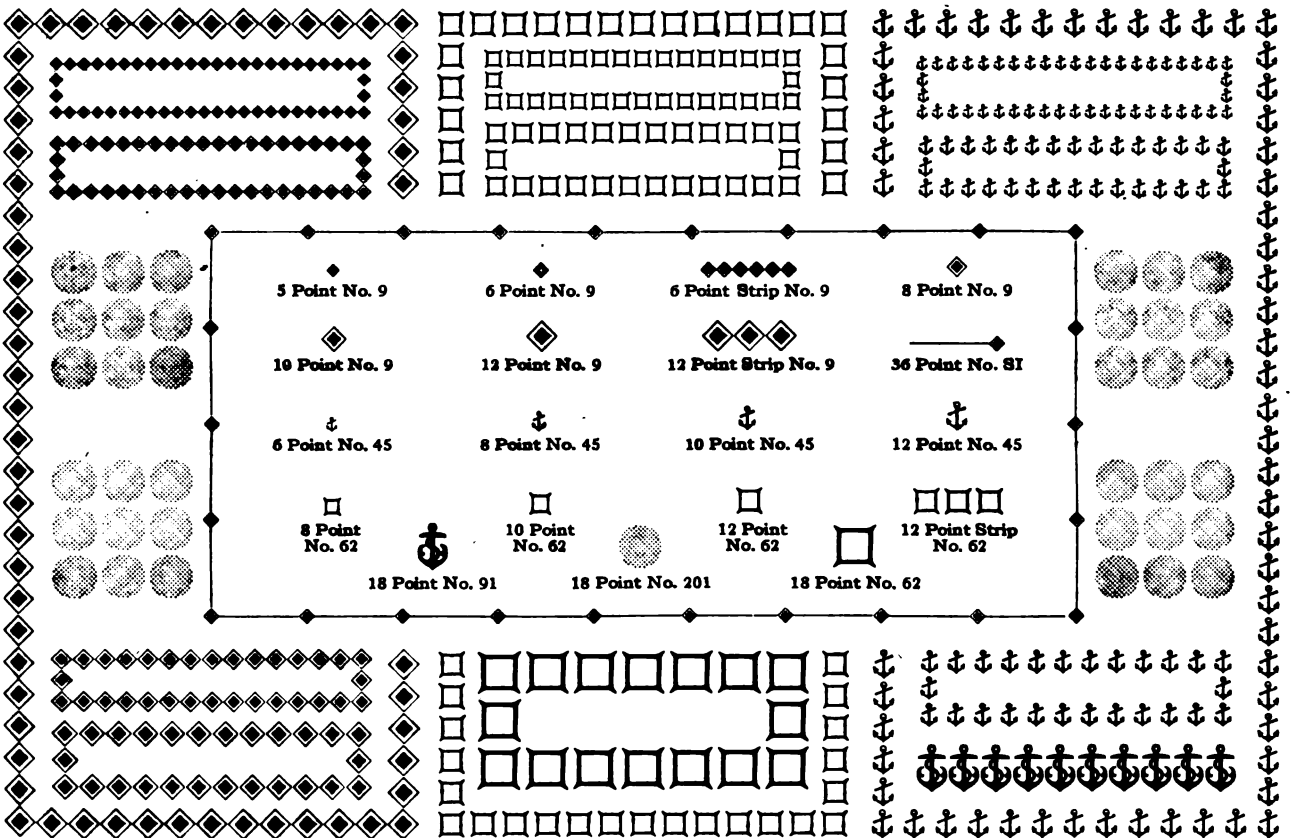
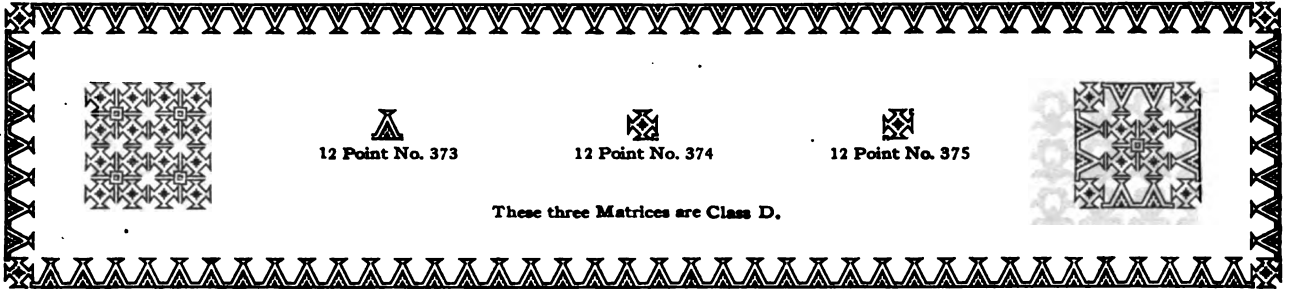
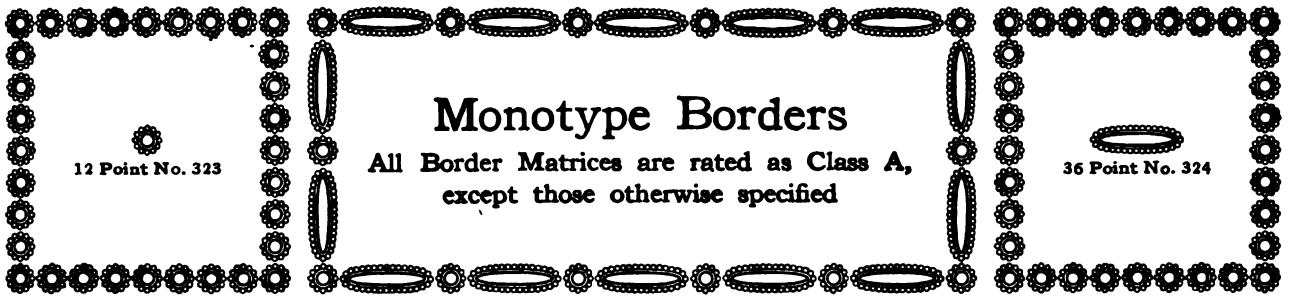

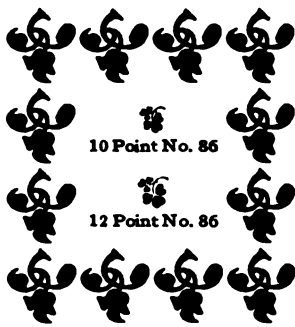

10 Point No. 86

12 Point No. 86

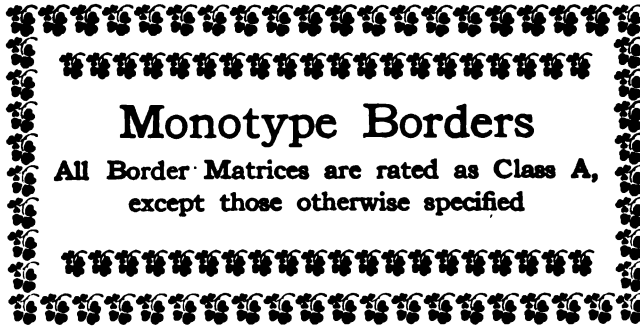

30 Point No. 125

# Monotype Borders

All Border Matrices are rated as Class A, except those otherwise specified

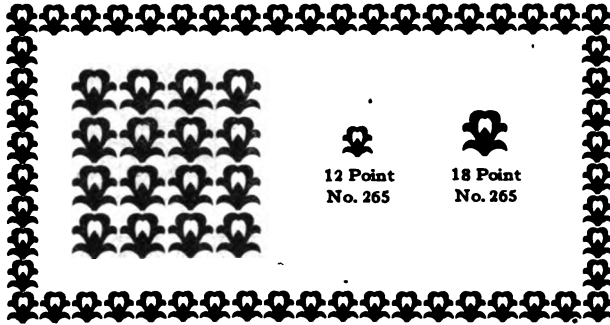

12 Point No. 265

18 Point No. 265

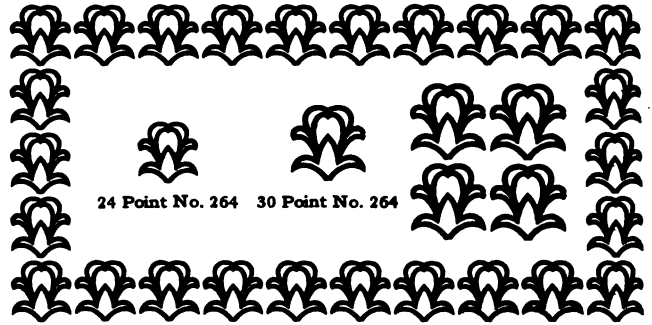

24 Point No. 264 30 Point No. 264

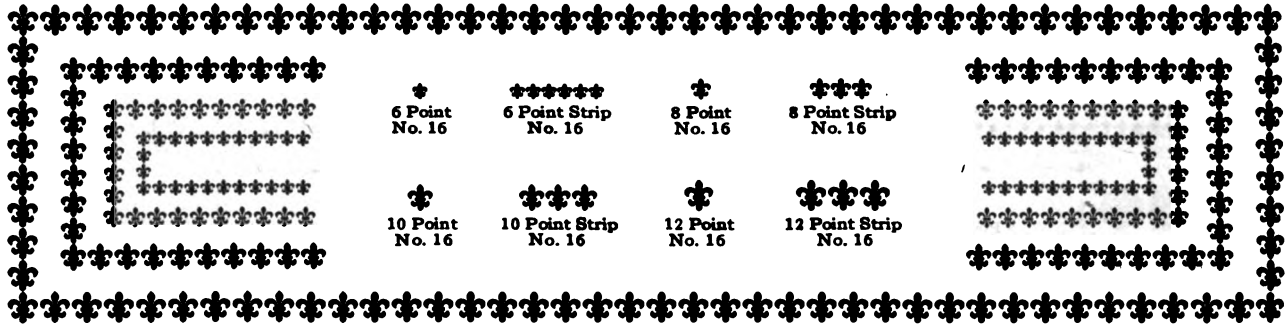

6 Point No. 16

6 Point Strip No. 16

8 Point No. 16

8 Point Strip No. 16

10 Point No. 16

10 Point Strip No. 16

12 Point No. 16

12 Point Strip No. 16

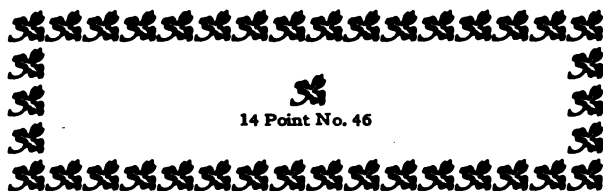

14 Point No. 46



14 Point No. 96

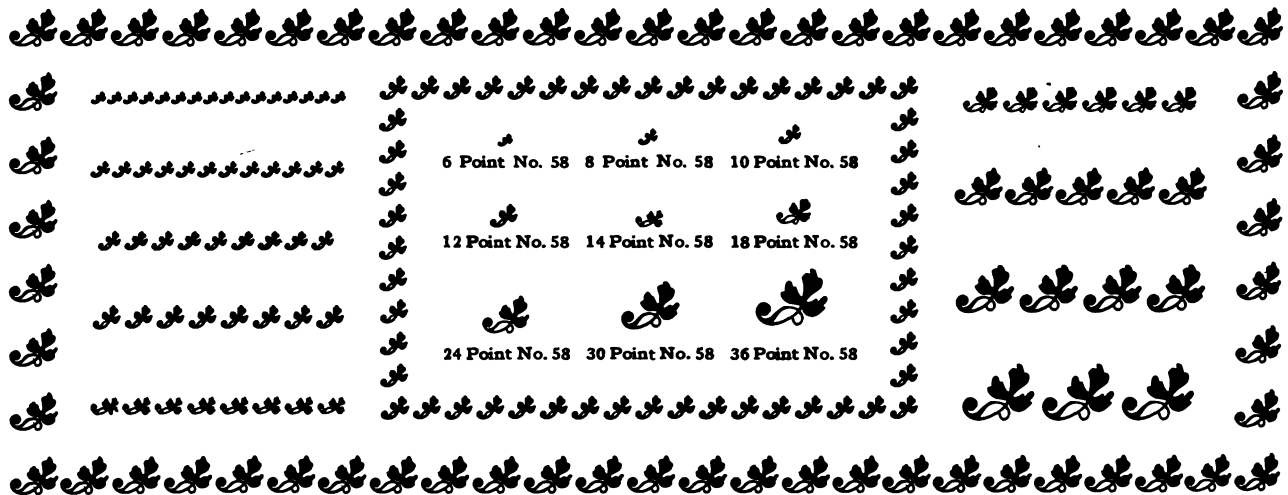

6 Point No. 58 8 Point No. 58 10 Point No. 58

12 Point No. 58 14 Point No. 58 18 Point No. 58

24 Point No. 58 30 Point No. 58 36 Point No. 58

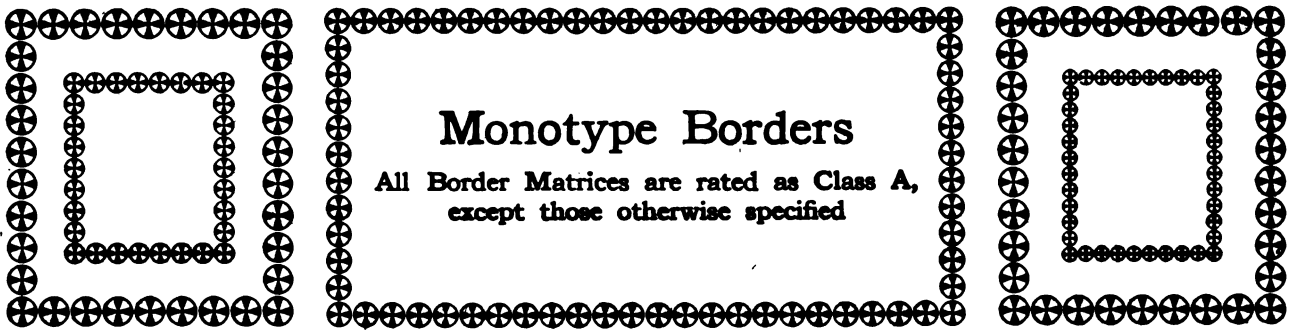

# Monotype Borders

All Border Matrices are rated as Class A,  
except those otherwise specified

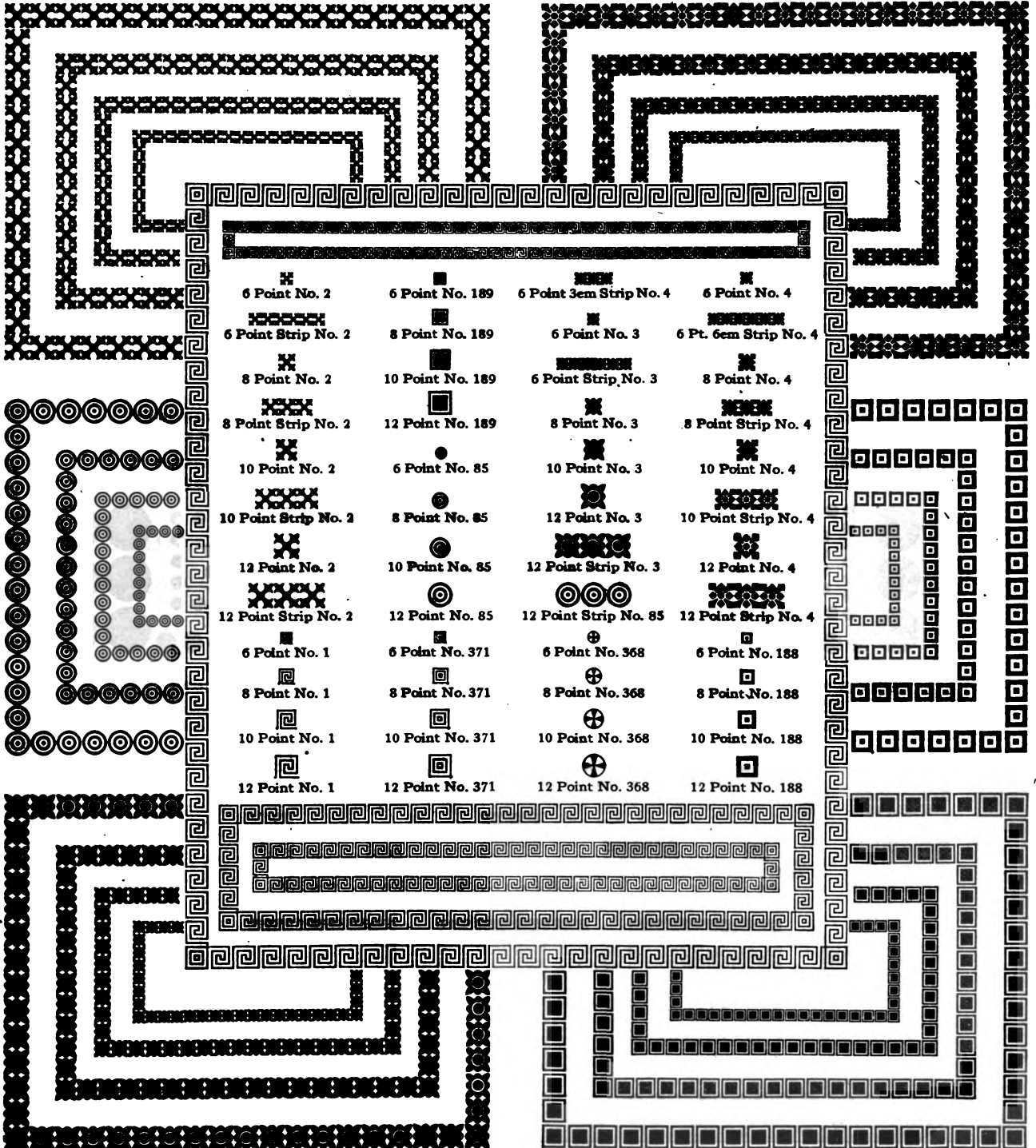



# Monotype Borders

All Border Matrices are rated as Class A,  
except those otherwise specified

6 Point  
No. 205

8 Point  
No. 205

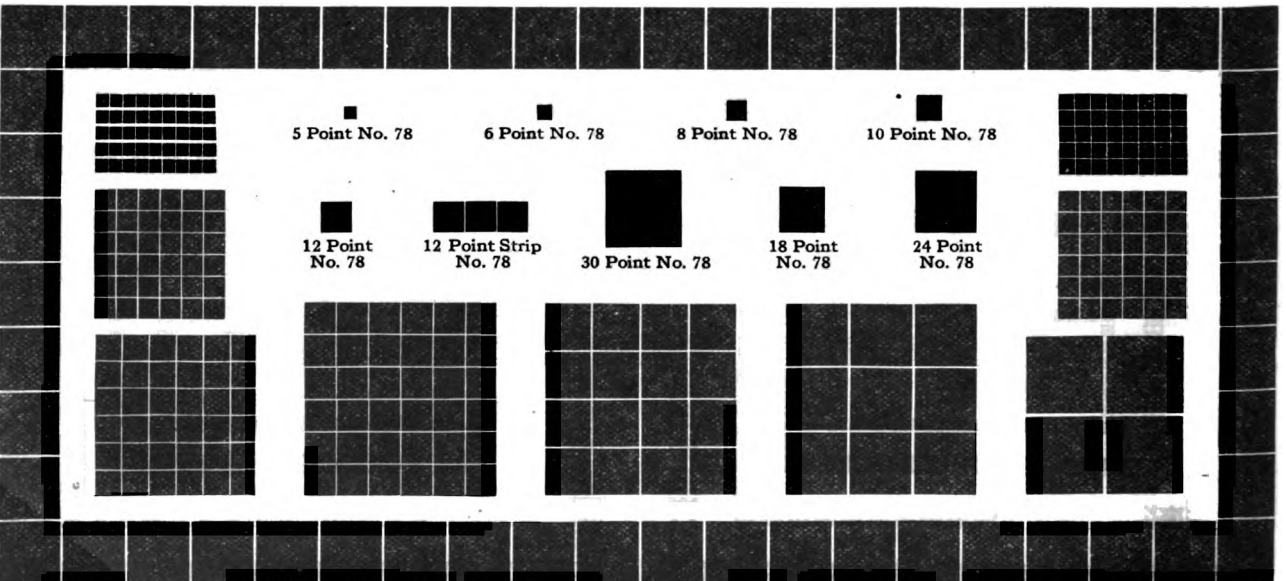
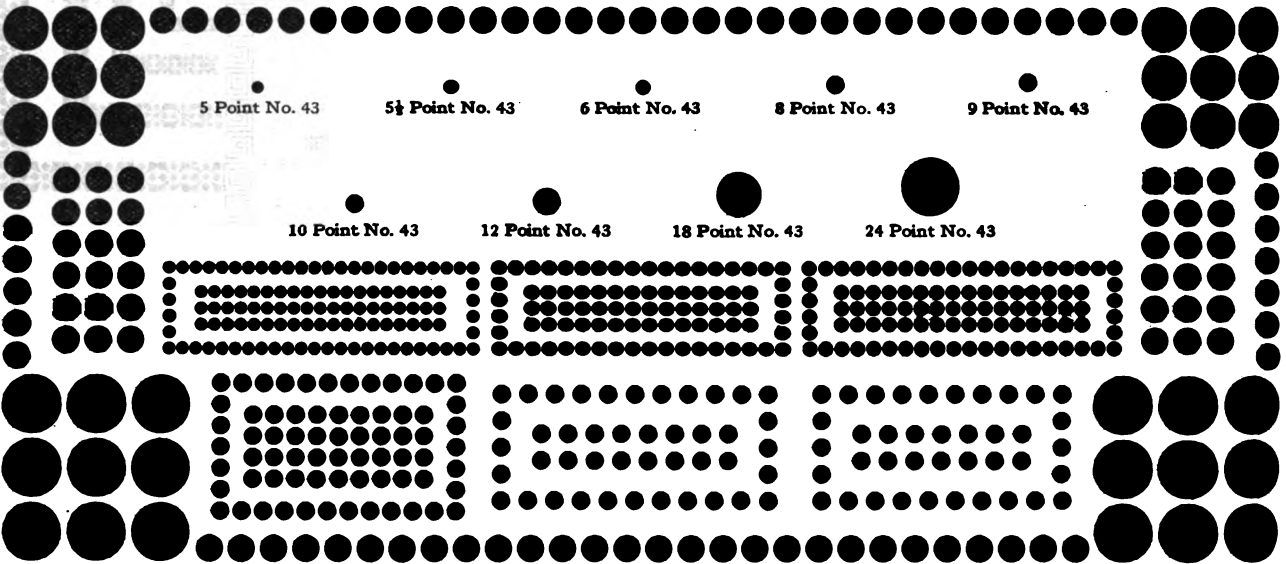
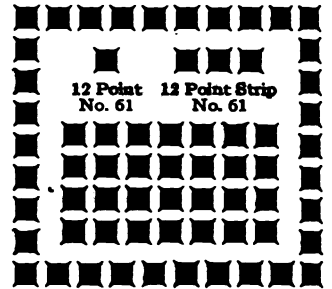
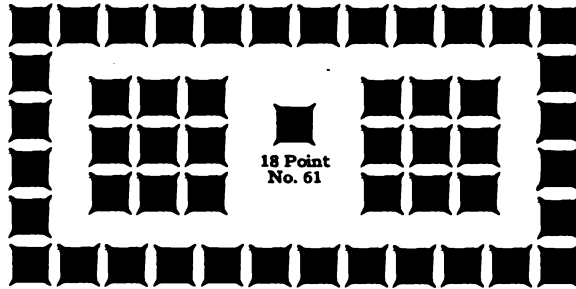
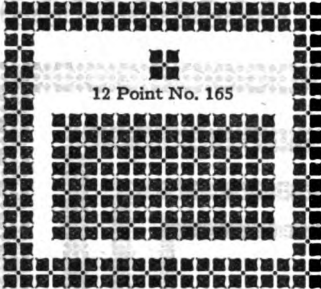

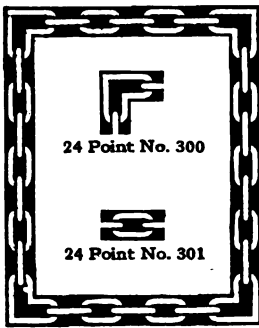

# Monotype Borders

All Border Matrices are rated as Class A, except those otherwise specified

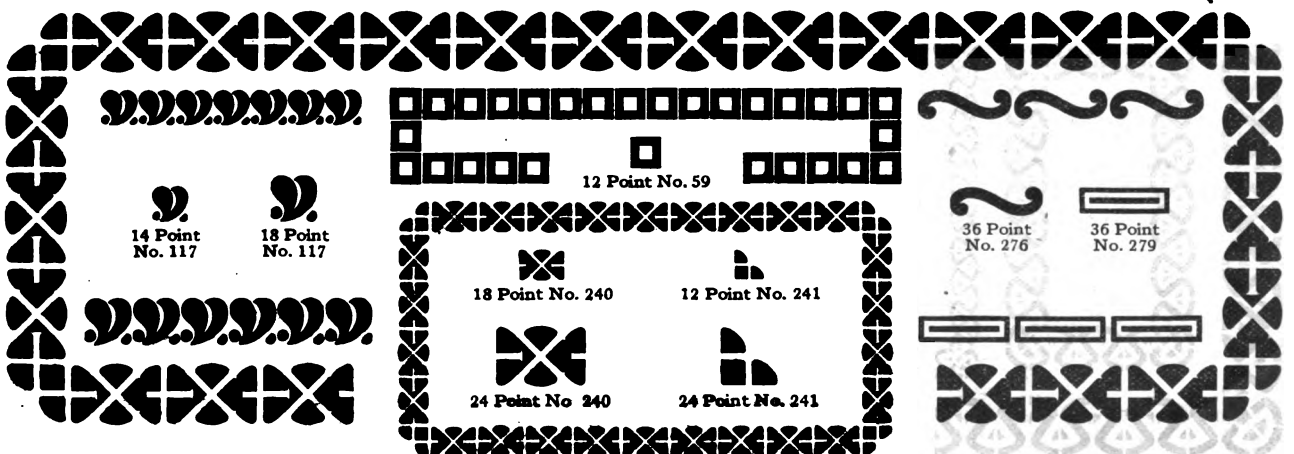
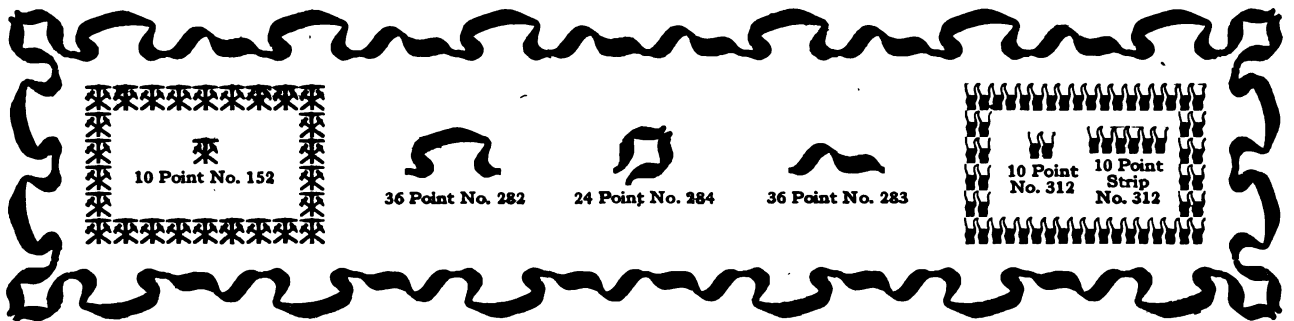
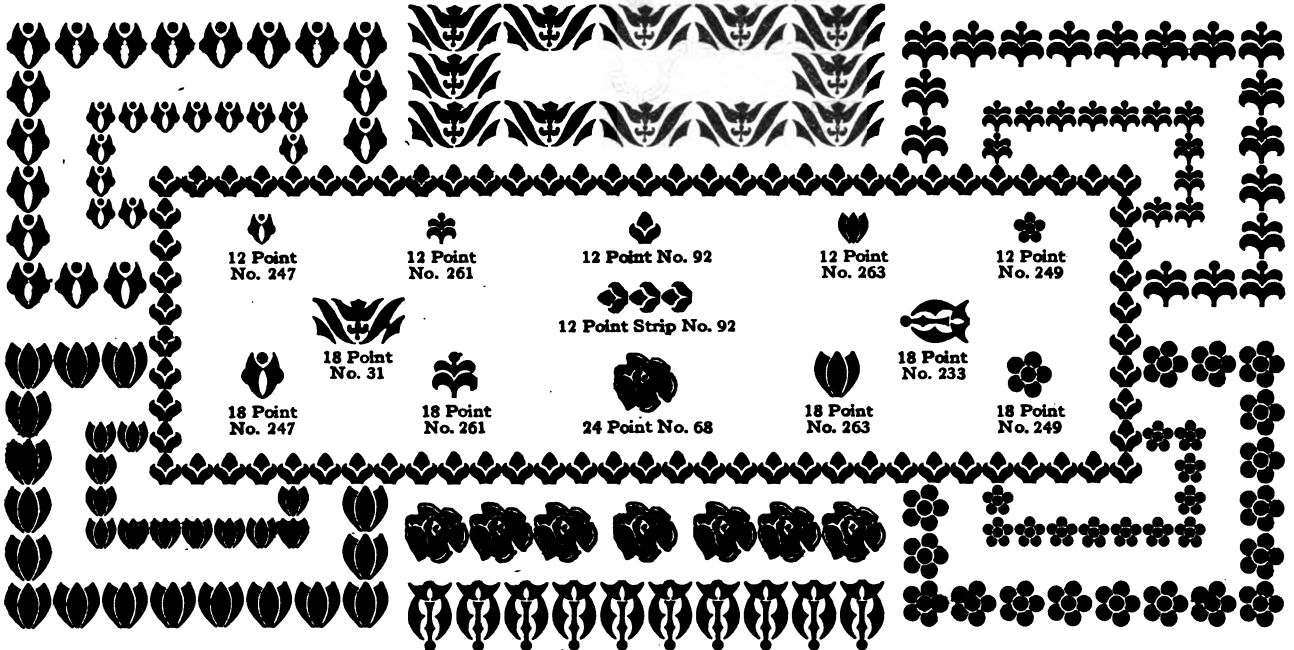
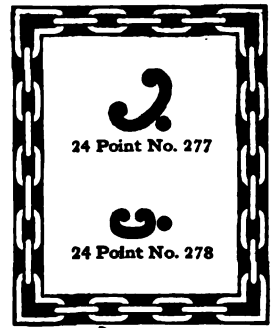

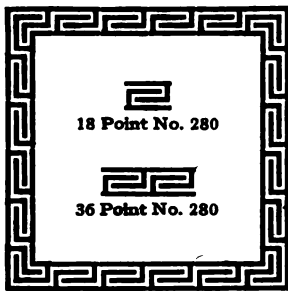

# Monotype Borders

All Border Matrices are rated as Class A,  
except those otherwise specified

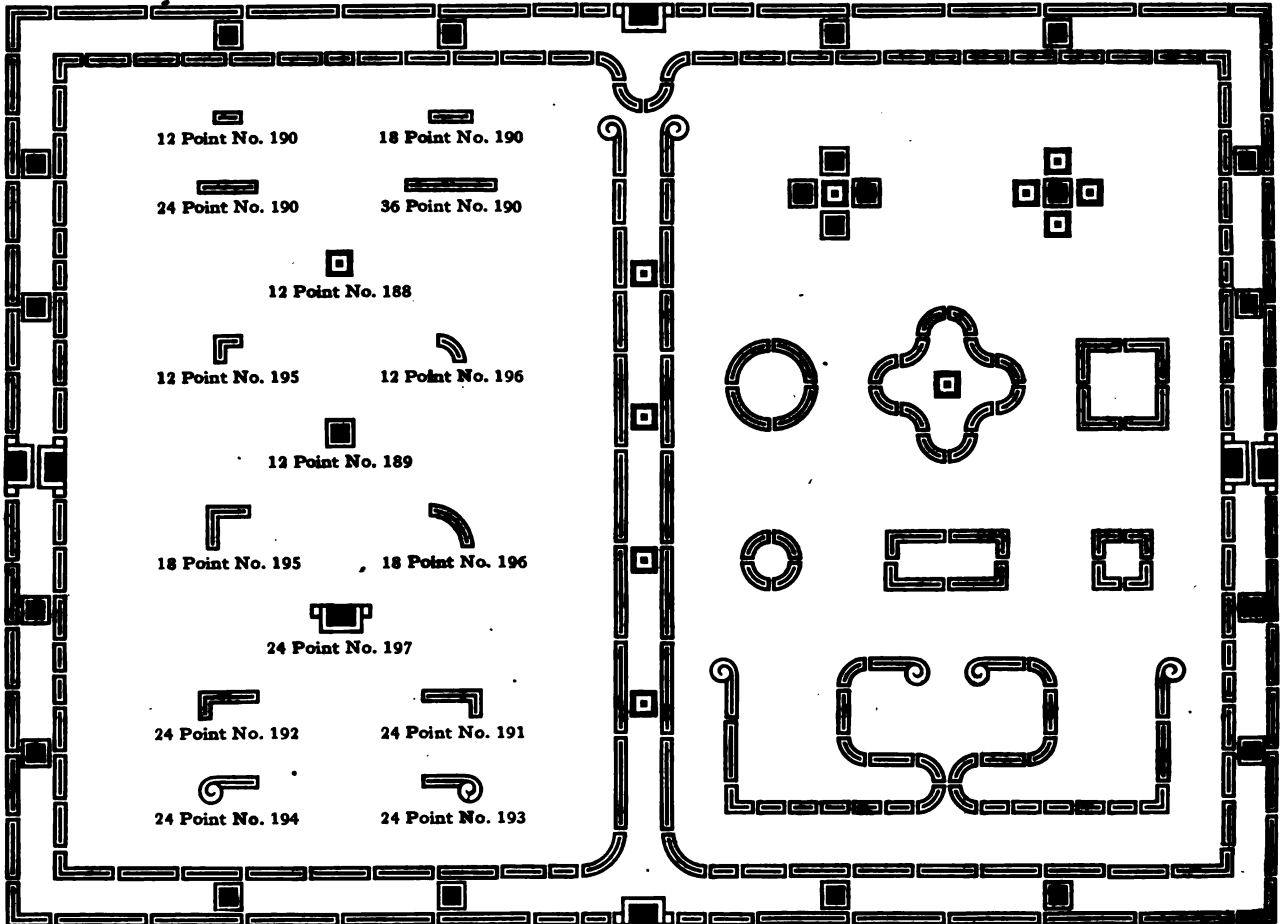
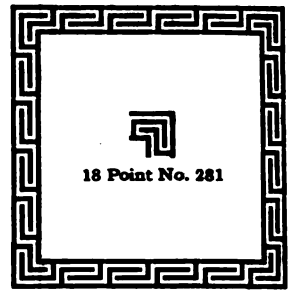

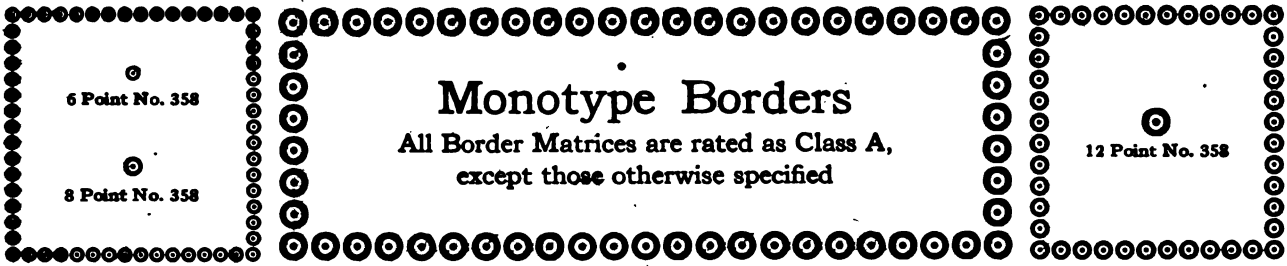

# Monotype Borders

All Border Matrices are rated as Class A,  
except those otherwise specified

6 Point No. 358

8 Point No. 358

12 Point No. 358

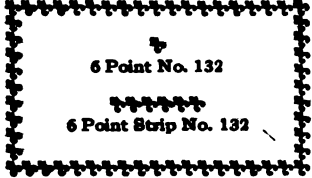

6 Point No. 132

6 Point Strip No. 132

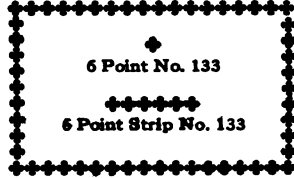

6 Point No. 133

6 Point Strip No. 133

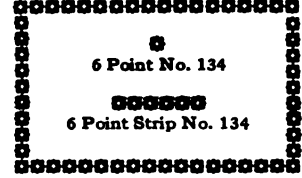

6 Point No. 134

6 Point Strip No. 134



6 Point No. 135

6 Point Strip No. 135

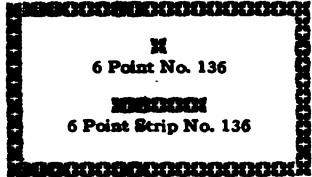

6 Point No. 136

6 Point Strip No. 136

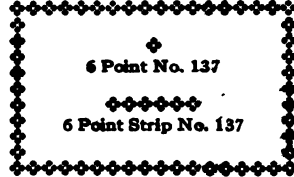

6 Point No. 137

6 Point Strip No. 137

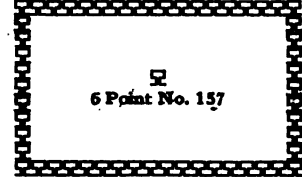

6 Point No. 157



6 Point No. 158

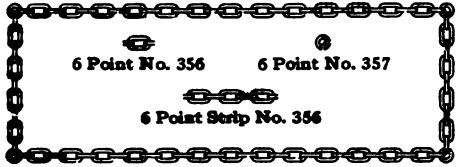

6 Point No. 356

6 Point Strip No. 356



6 Point No. 15

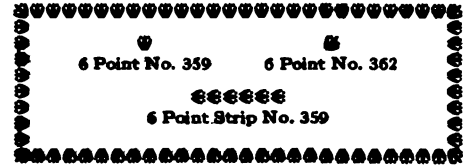

6 Point No. 359

6 Point Strip No. 359

6 Point No. 362

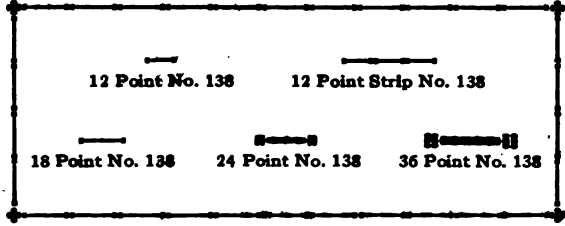

12 Point No. 138

12 Point Strip No. 138

18 Point No. 138

24 Point No. 138

36 Point No. 138

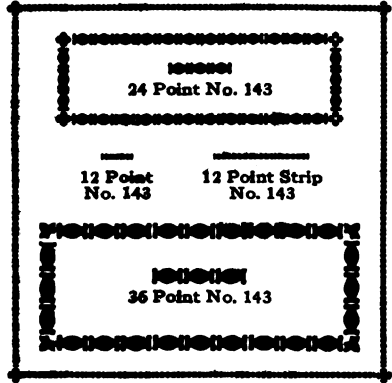
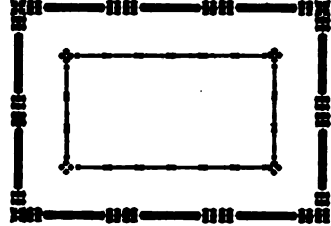

24 Point No. 143

12 Point No. 143

12 Point Strip No. 143

36 Point No. 143

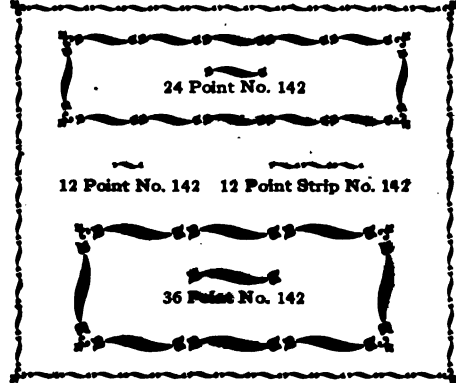

24 Point No. 142

12 Point No. 142

12 Point Strip No. 142

36 Point No. 142

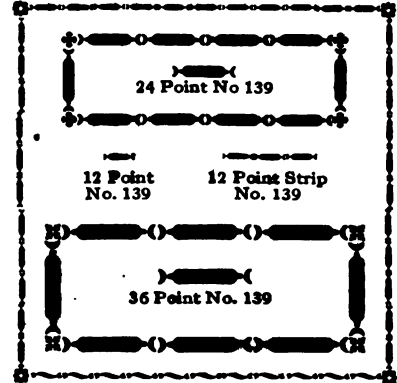

24 Point No. 139

12 Point No. 139

12 Point Strip No. 139

36 Point No. 139

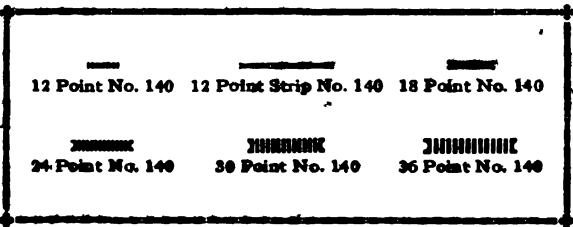
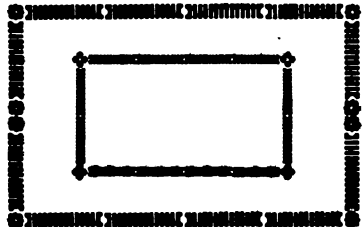

12 Point No. 140

12 Point Strip No. 140

18 Point No. 140

24 Point No. 140

30 Point No. 140



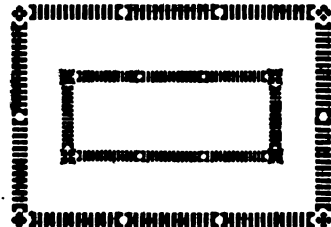





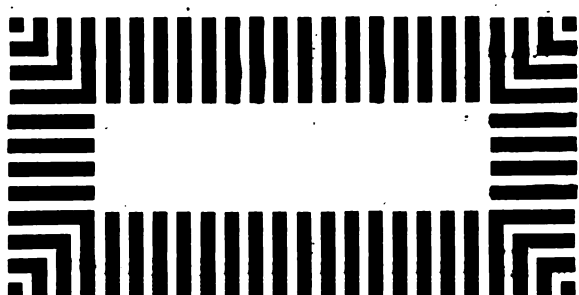
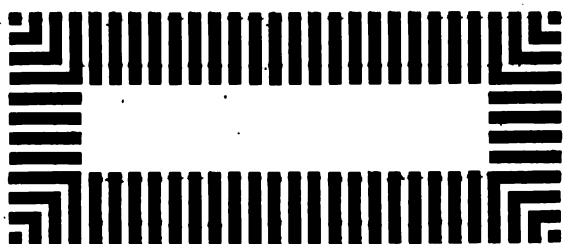
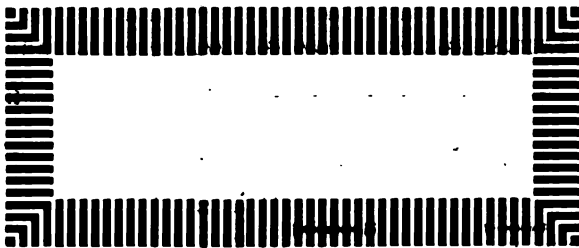
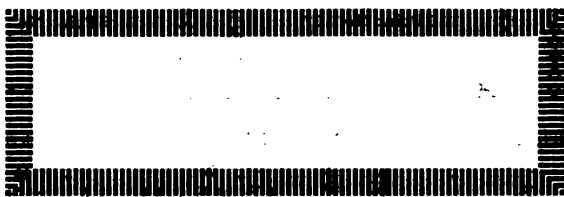
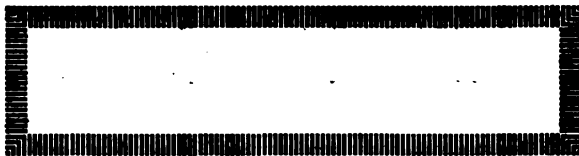











36 Point No. 140



# Monotype Borders

All Border Matrices are rated as Class A,  
except those otherwise specified



|   |  |
|---|--|
| <br>6 Point No. 88           | <br>6 Point No. 89    |
| <br>6 Point Strip No. 88    |  |
| <br>8 Point No. 88           | <br>8 Point No. 89    |
| <br>8 Point Strip No. 88   |  |
| <br>10 Point No. 88          | <br>10 Point No. 89   |
| <br>10 Point Strip No. 88  |  |
| <br>12 Point No. 88        | <br>12 Point No. 89 |
| <br>12 Point Strip No. 88 |  |
| <br>18 Point No. 88        | <br>18 Point No. 89 |
| <br>24 Point No. 88        | <br>24 Point No. 89 |
| <br>30 Point No. 88        | <br>30 Point No. 89 |
| <br>36 Point No. 88       | <br>36 Point No. 89 |

# *The* LEGIBILITY OF SINGLE TYPES

**R**EADING matter composed with *single letters* is read with less conscious effort. The reasons are simple. Reading is a series of pauses and fixations of attention—interrupted movement of the angle of vision. The shortness and infrequency of these pauses are the measure of ease in reading. Easy legibility is in the instant recognition of word-forms. The more compact the words, the quicker recognized—in the highest degree, the objective mind has naught to do but assimilate the thought presented.

Type composed by a machine which has not the mechanical limitation of interposed space between letters is more easily read. It aids “pulling power” by not distracting the attention of the reader with conscious physical activity.



LANSTON MONOTYPE MACHINE CO.  
PHILADELPHIA

4

4











MAR 1 - 1932

